

COPYRIGHT:  
MODEL AERONAUTICAL  
PRESS LTD.  
38 CLARENDON ROAD  
WATFORD. HERTS  
Issued free with July 1965  
'AEROMODELLER'

F4 (3/16)	F3 (cut for escapement)
F5 (1/8ply)	F3 1/4"
Note grain directions	

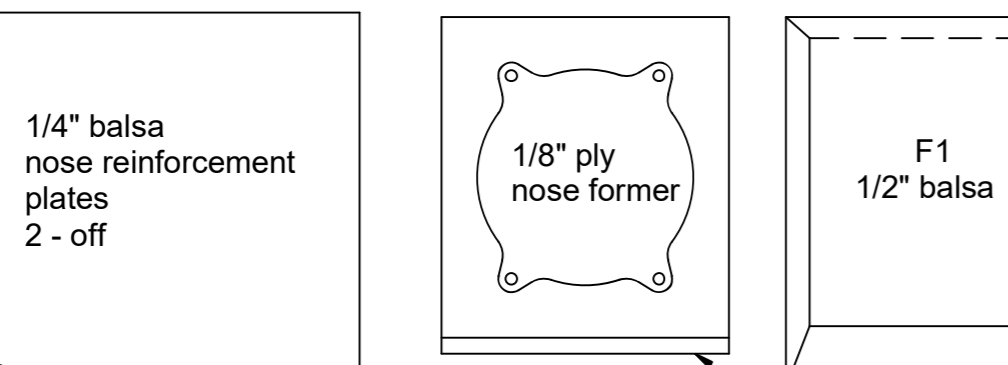

# SHARKFACE

A 22 INCH WING SPAN RADIO CONTROL MODEL FOR UP TO 1.5 c.c. ENGINES AND RUDDER ONLY CONTROL

**by Eric Clutton**

