

**FUSELAGE UPPER-ASSEMBLY ORDER:**

Build the top half of the fuse over the plan.

1. Keels K1--pin to plan.
2. All "T" Former parts F2T thru F10.
3. Upper Keels K2 and K3.

4. Horizontal Stabilizer Supports HS.
5. Stringers--all fuselage stringers are 1/8" x 3/16" balsa.
  1. add enough to make the assembly rigid when unpinned from the board

**FUSELAGE LOWER-ASSEMBLY ORDER:**

Build the lower half of the fuse free from the plan--side view drawing shown for reference.

1. Align and laminate Firewall parts F0 and F1.
2. Attach Firewall to front Keels.
3. Wing pin WP--reinforce pin hole in F3B.
4. Wing Bolt Boss--assemble parts WB1 and WB2 and attach to former F6B (see detail).
  1. Use 1/4-20 hardware to fasten the wing to the Wing Bolt Boss
5. All "B" Former parts F2B thru F9B.
  1. Glue all parallel to their "T" counterparts.
  2. Except for F6B, use keel K5 to set angle
6. Keels K4 and K5.
7. Servo tray SERVO.
8. Wing Saddles WS--wet outer surface of these parts and they will curve into place.
9. Stringers--finish 'em off!

**MOTOR MOUNT:**

The nose on the Devastator is shorter than it appears at first glance. In order to get as much weight forward as possible, this design uses an integrated Motor Mount/Battery Tray.

When assembled as shown below, the Motor Mount will provide 2 degrees of right and down thrust.

Once completed, the assembly will slide through the Firewall and formers F2 and F3. Drill a hole down through Firewall F0 and MMT for a retaining pin to keep the Motor Mount in place when installed.

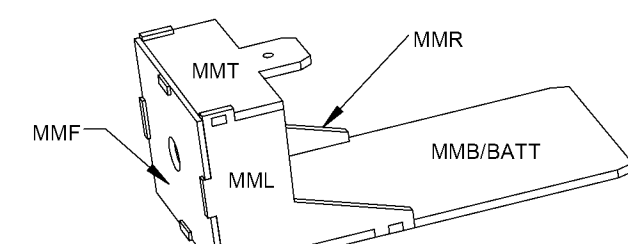

Add three 1/8" hard balsa rails at the bottom corners of the firewall opening where shown.

Bevel the upper rail between Firewall and F2 to accept battery tray BATT

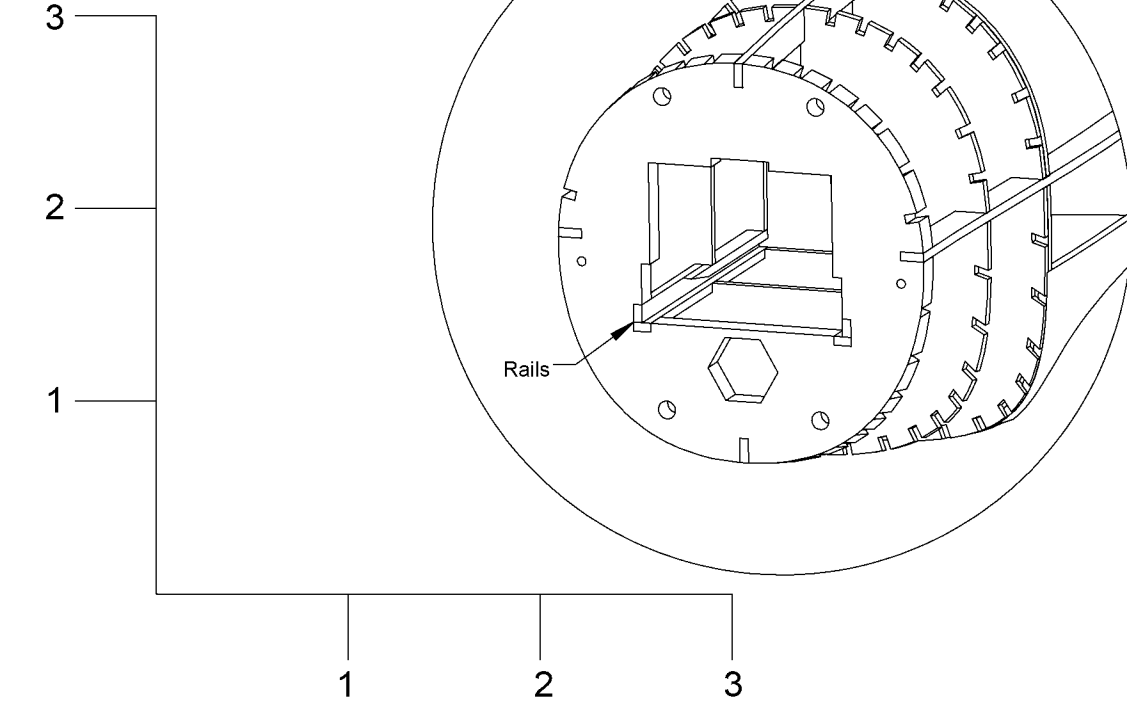

**COWL-ASSEMBLY ORDER:**

1. Preassemble Cowl Opening rings C1 thru C3.
2. Stack and glue the rings together--align them with the alignment hole.
  1. The hole will be the port for the cowl machine gun later.
3. Glue two rails C7 so that the sides of C7 are perpendicular to ply former C4.
  1. Use angle gauge below to tip the edge of C7 toward the cowl opening.
4. Mount Cowl Opening to top of rails C7; add C9 to true the Cowl Opening to the ply former.
5. Glue the rest of the cowl rails into place.
6. Sheet the assembly from C3 to C4 with 1/16" balsa.
7. Attach Cowl to Firewall F0 with rare earth magnets.

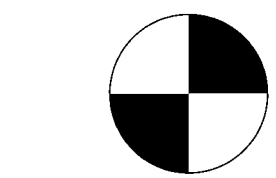
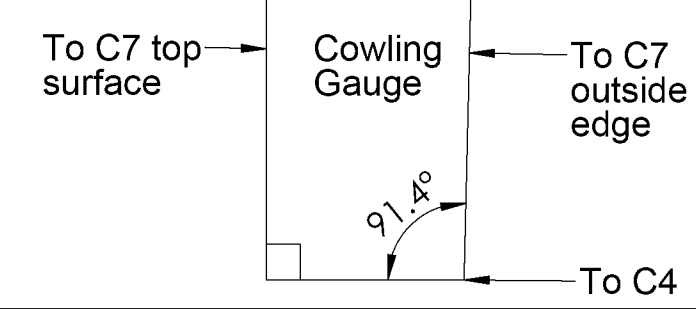
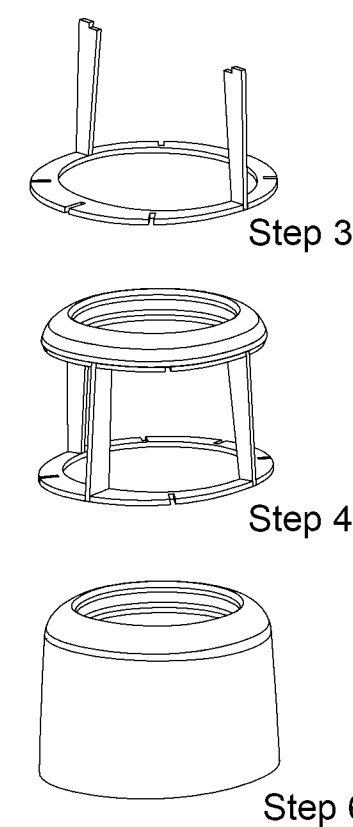

CG shown is at 25% MAC  
3 11/16" / 94mm from back of F3

1 inch reference square

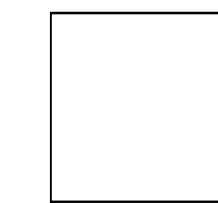

Copyright 2019 **AMA** and **ModelAviation**  
Copying for resale of this drawing without the written approval or consent of AMA is expressly prohibited.

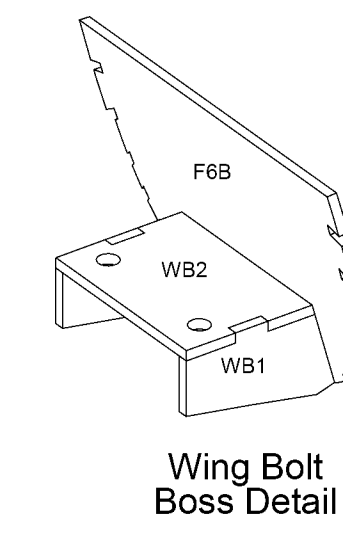

Wing Bolt Boss Detail

PROTOTYPE SPECIFICATIONS	
Wingspan	60"
Length	41 7/8"
Weight	75oz
Wing Area	635 sq in
Power	FMS 4258 650kV
Propellor	13x8 3-blade
Battery	4S 3600mAh

**TAIL GROUP ASSEMBLY--Fin and Rudder**

Sheeting the fin and horizontal stabilizer and covering the rudder and elevators as open frameworks provides durability with a scale appearance.

The design of the tail group replicates the inset hinges found in the full-scale Devastator. Ply ribs in the fin and stabilizer extend back into the rudder and elevators. This may appear more complicated than standard hinges, but the result is worth the time. Following the assembly order below will make success easily attainable.

1. Begin tail group assembly by laminating outlines from three strips of 1/16" x 1/2" balsa around forms.
2. Pin the cured outlines into place over the plan.
3. Install the tail framework parts in numerical order.
  1. Complete the fin framework first.
  2. Build the leading edge of the rudder.
    1. Pin down parts R1 thru R3.
    2. Assemble parts R4 thru R6 to form a pocket around hinge post V4--be careful not to glue the this assembly to the fin framework.

4. Install remaining ribs R7 thru R15
5. Separate the Rudder from the Fin by cutting through the outline where shown.
6. Sheet the upper Fin with 1/16" balsa while pinned flat to the board.
7. Unpin and remove the support foam from the bottom of the Fin and sheet the bottom side.
8. Sand to shape.
9. Upper Hinge--drill through R4, V4, and R6 and insert a 1/8" diameter hinge pin.
10. Lower Hinges--hinge R3 to Fin at V8 and at fuse F9 with hinge of choice where shown.

Plan No. 1118

**INFIELD ENGINEERING** by Paul Kohlmann

**60" Douglas TBD Devastator**

Size: X Dwg. No.: Douglas Devastator Rev: A

Scale: 1:1 Weight: 75oz Sheet 1 of 4

**WING FILLET**

Use the templates below to make the fillet parts:

1. Wing Platform—cut from 1/16" balsa or 1/32" ply.
  1. Fit Platform to upper wing surface
  2. Glue the Platform to the bottom edge of the Wing Saddle WS.
2. Bottom—cut from 1/8" balsa
  1. Epoxy to back edge of Wing Platform and fuselage
3. Side Panels—cut from 1/16" balsa or thick cardstock.
  1. Wet each Panel and gently shape to fit.
  2. Work from the Rear to the Front.
  3. Glue to Wing Platform and fuselage.
  4. Add bracing from scrap balsa as needed.

**DIHEDRAL**

The dihedral is set by installing center wing rib W1 at the angle provided by the Dihedral Gauge.

Completed wing assembly should measure 1.9"/48mm from board to bottom of W10 when wings are level and supported by sheeted W1.

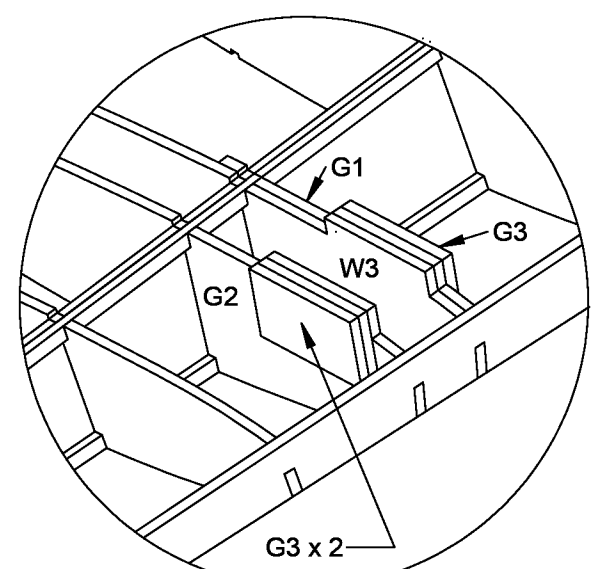
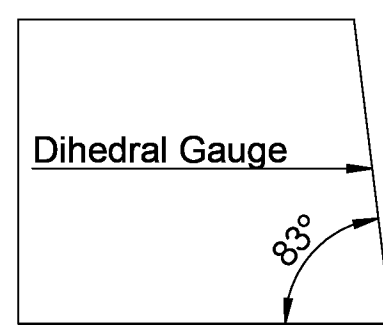

Main Gear Detail

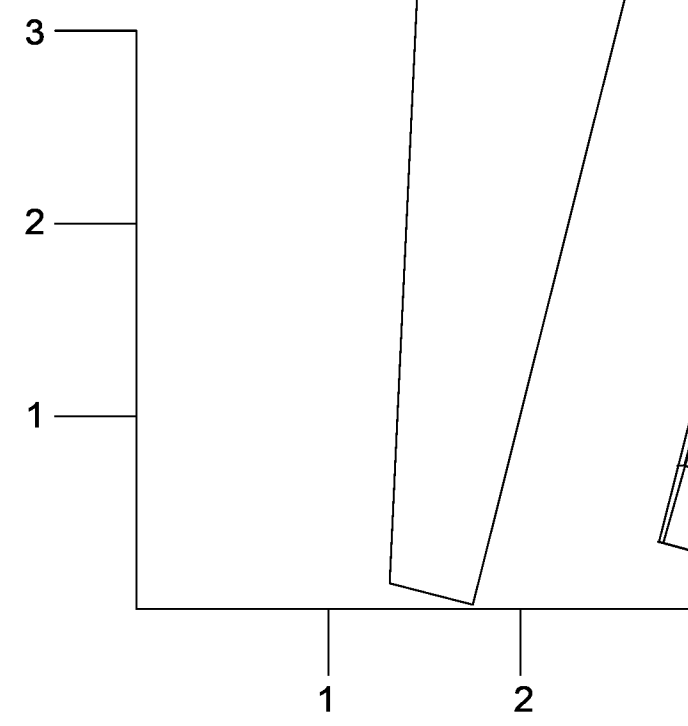
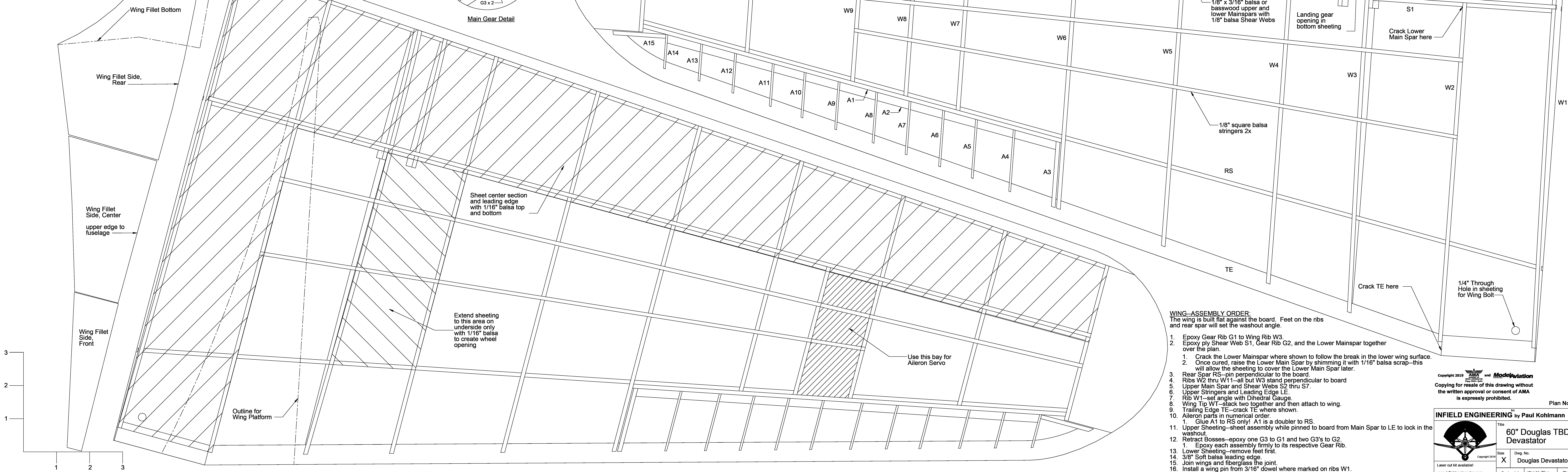

**WING-ASSEMBLY ORDER:**  
The wing is built flat against the board. Feet on the ribs and rear spar will set the washout angle.

1. Epoxy Gear Rib G1 to Wing Rib W3.
2. Epoxy ply Shear Web S1, Gear Rib G2, and the Lower Mainspar together over the plan.
  1. Crack the Lower Mainspar where shown to follow the break in the lower wing surface.
  2. Once cured, raise the Lower Main Spar by shimming it with 1/16" balsa scrap—this will allow the sheeting to cover the Lower Main Spar later.
3. Rear Spar RS—pin perpendicular to the board.
4. Ribs W2 thru W11—all but W3 stand perpendicular to board
5. Upper Main Spar and Shear Webs S2 thru S7.
6. Upper Stringers and Leading Edge LE.
7. Rib W1—set angle with Dihedral Gauge.
8. Wing Tip WT—stack two together and then attach to wing.
9. Trailing Edge TE—crack TE where shown.
10. Aileron parts in numerical order.
  1. Glue A1 to RS only! A1 is a doubler to RS.
11. Upper Sheeting—sheet assembly while pinned to board from Main Spar to LE to lock in the washout.
12. Retract Bosses—epoxy one G3 to G1 and two G3's to G2.
  1. Epoxy each assembly firmly to its respective Gear Rib.
13. Lower Sheeting—remove feet first.
14. 3/8" Soft balsa leading edge.
15. Join wings and fiberglass the joint.
16. Install a wing pin from 3/16" dowel where marked on ribs W1.

Copyright 2010 and   
Copying for resale of this drawing without the written approval or consent of AMA is expressly prohibited.

Plan No. 1118

INFIELD ENGINEERING by Paul Kohlmann

Title		60" Douglas TBD Devastator	
Size	X	Dwg. No.	Douglas Devastator
Rev	A	Scale:	1:1
www.infieldengineering.com		Weight:	75oz
		Sheet:	2 of 4

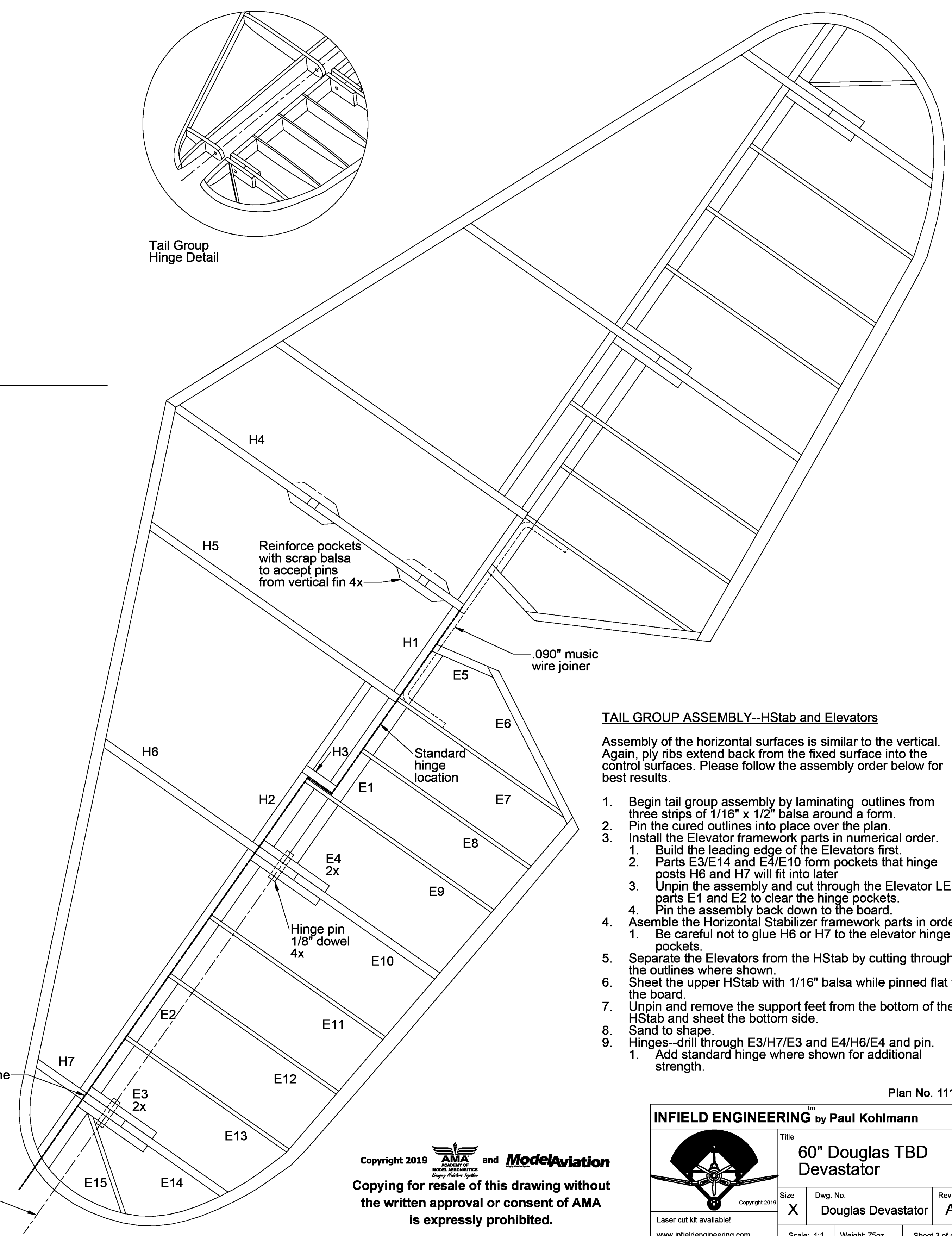
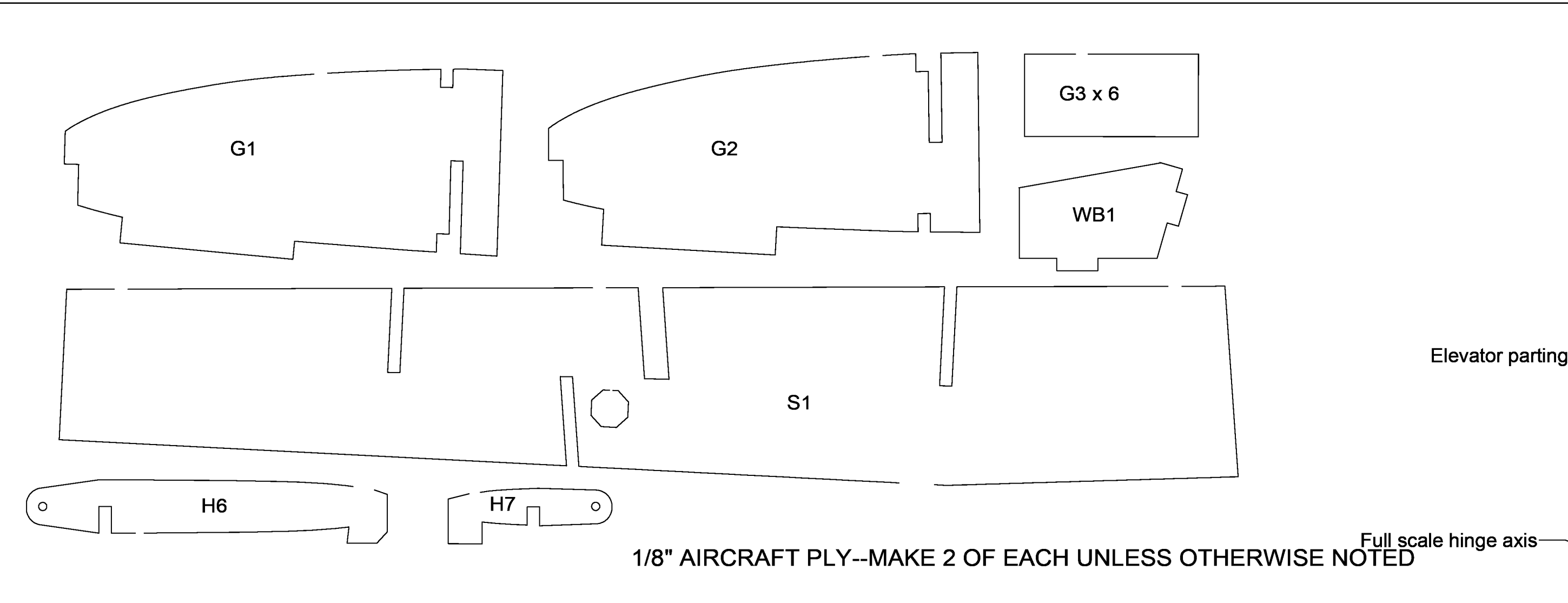
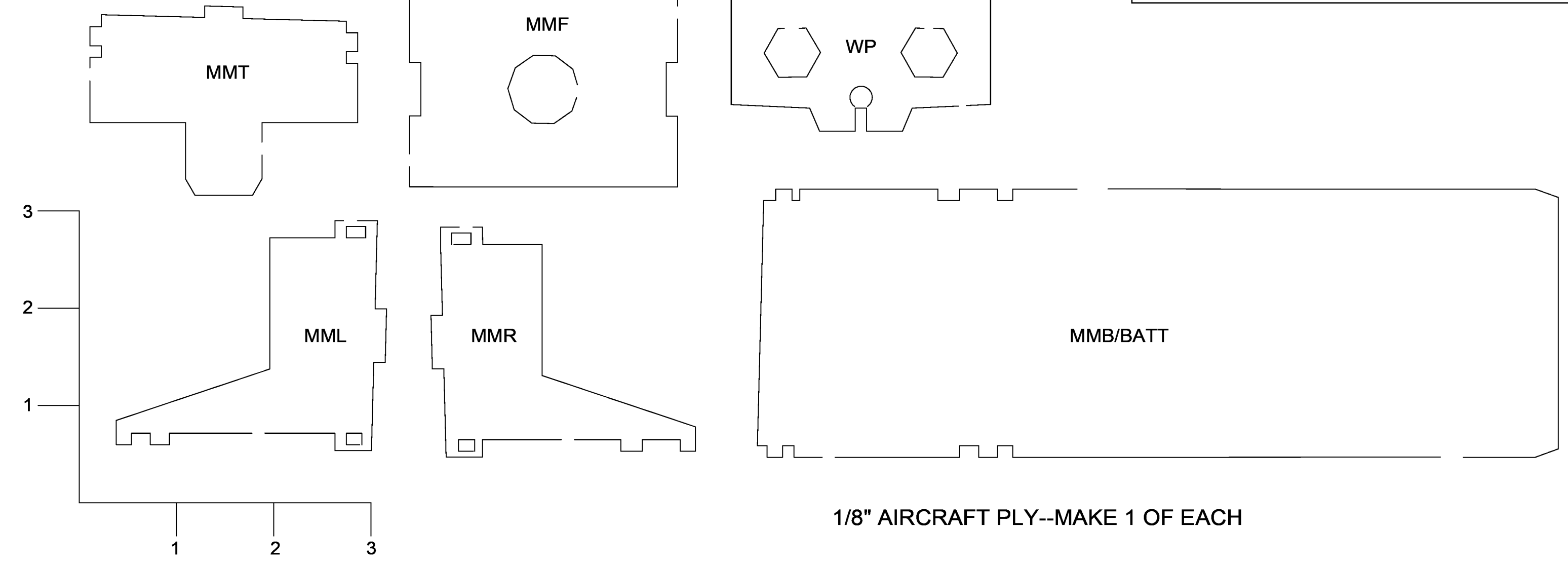
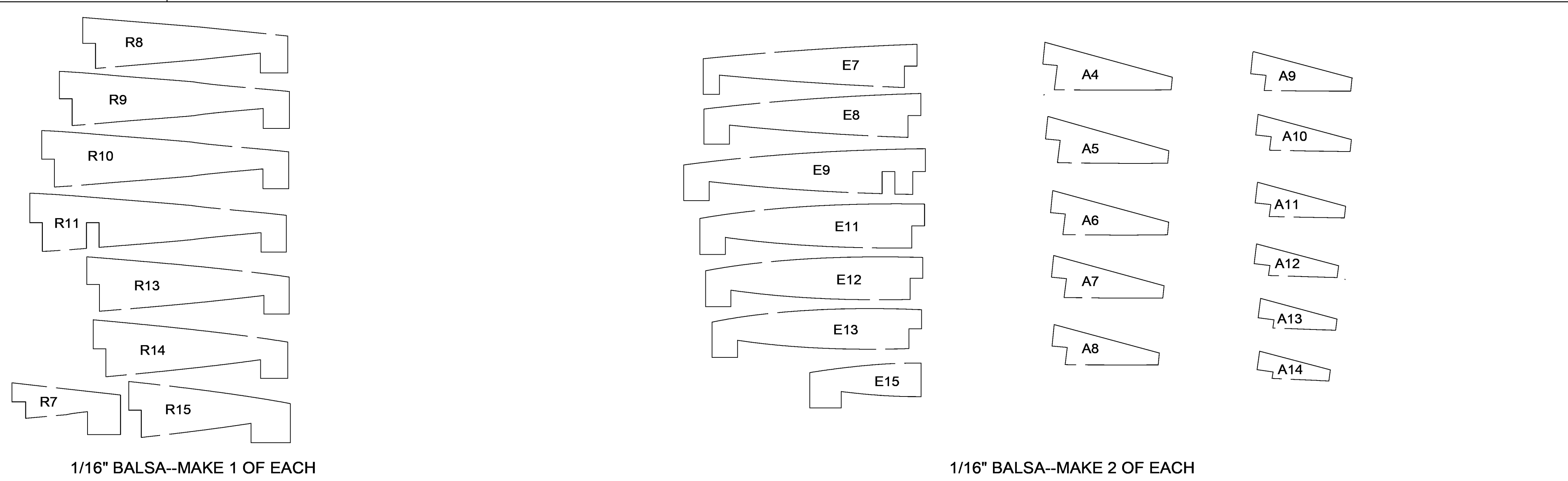
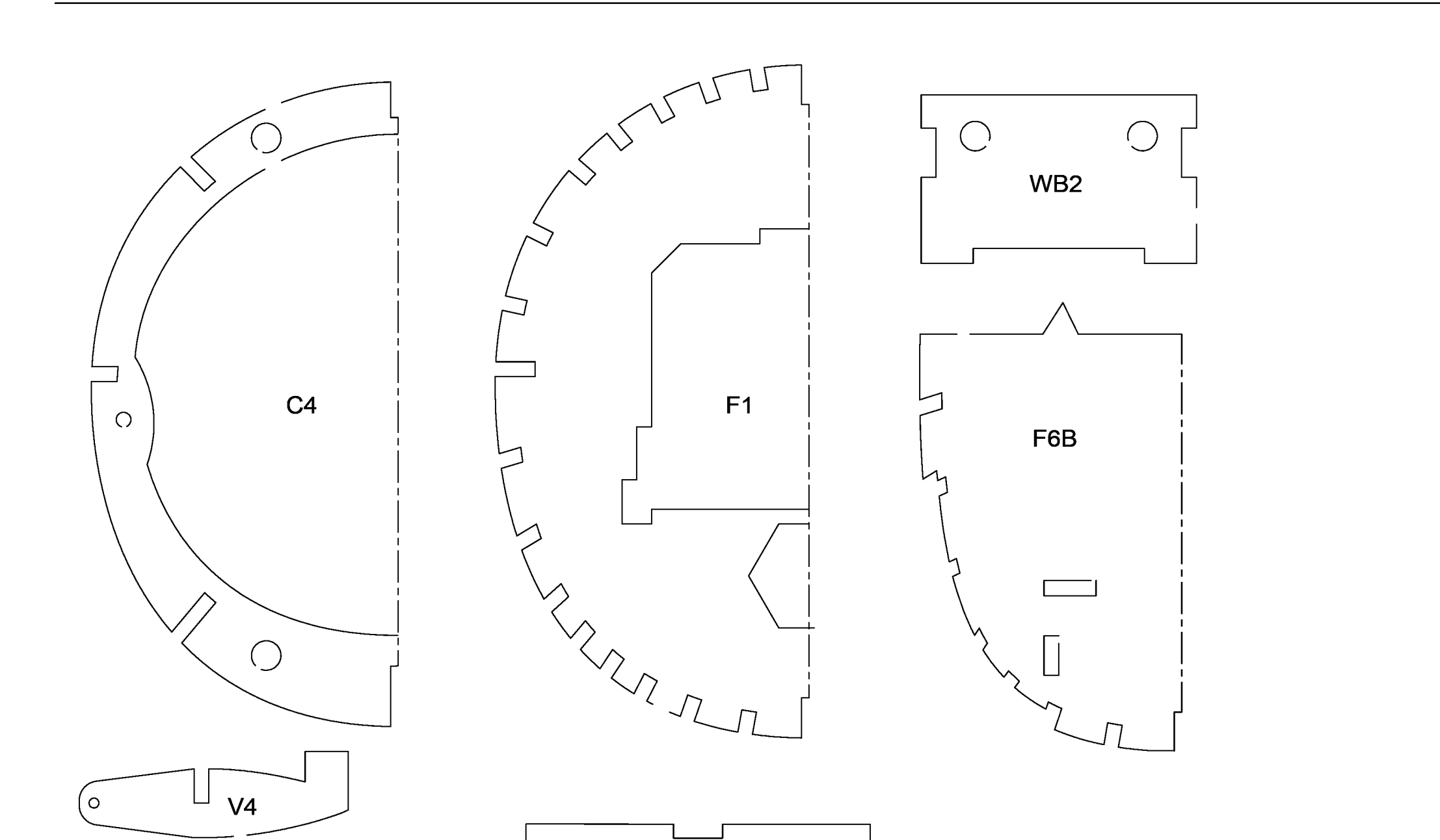
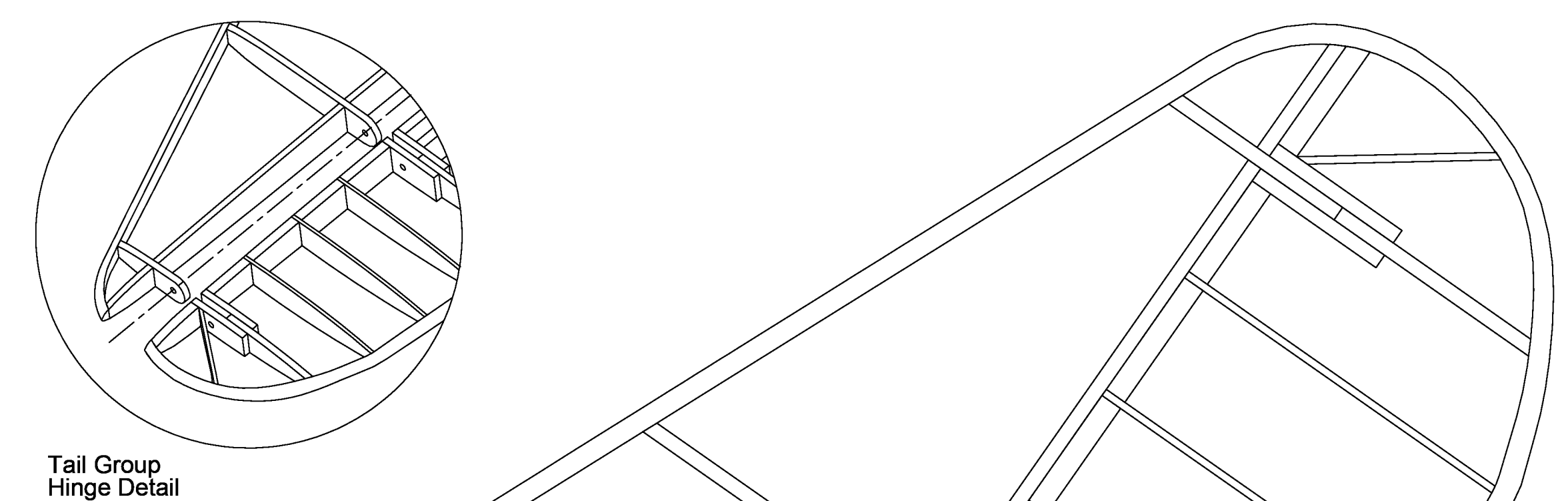
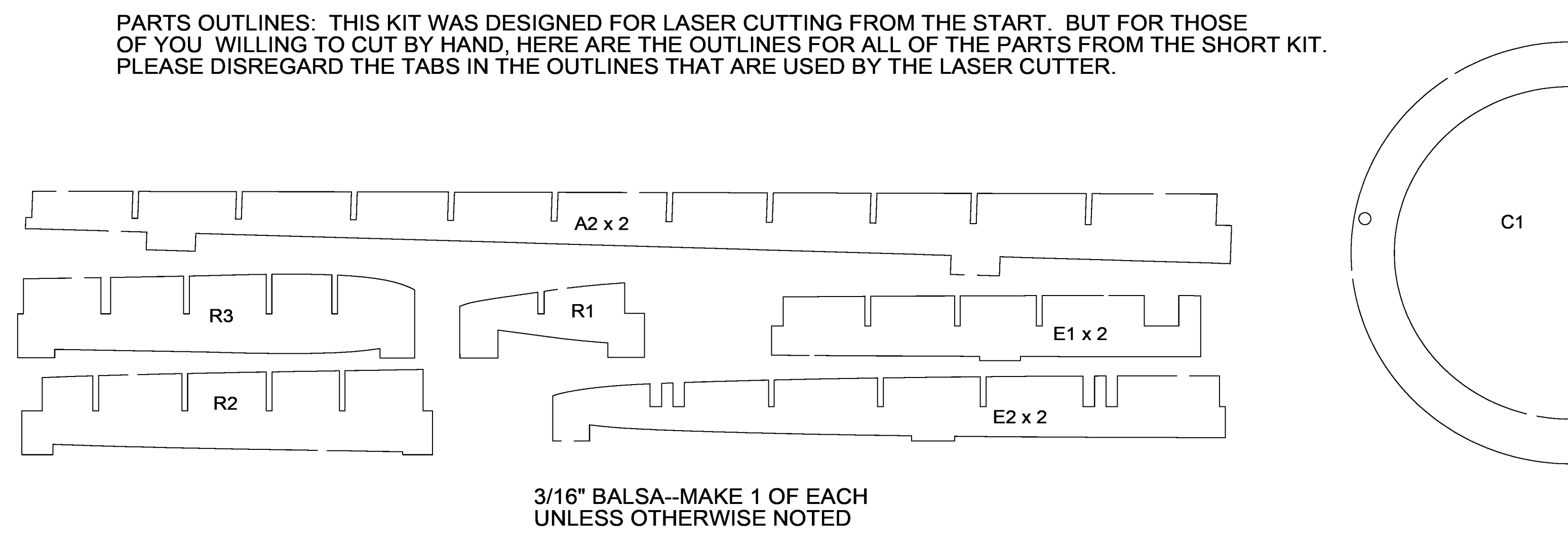
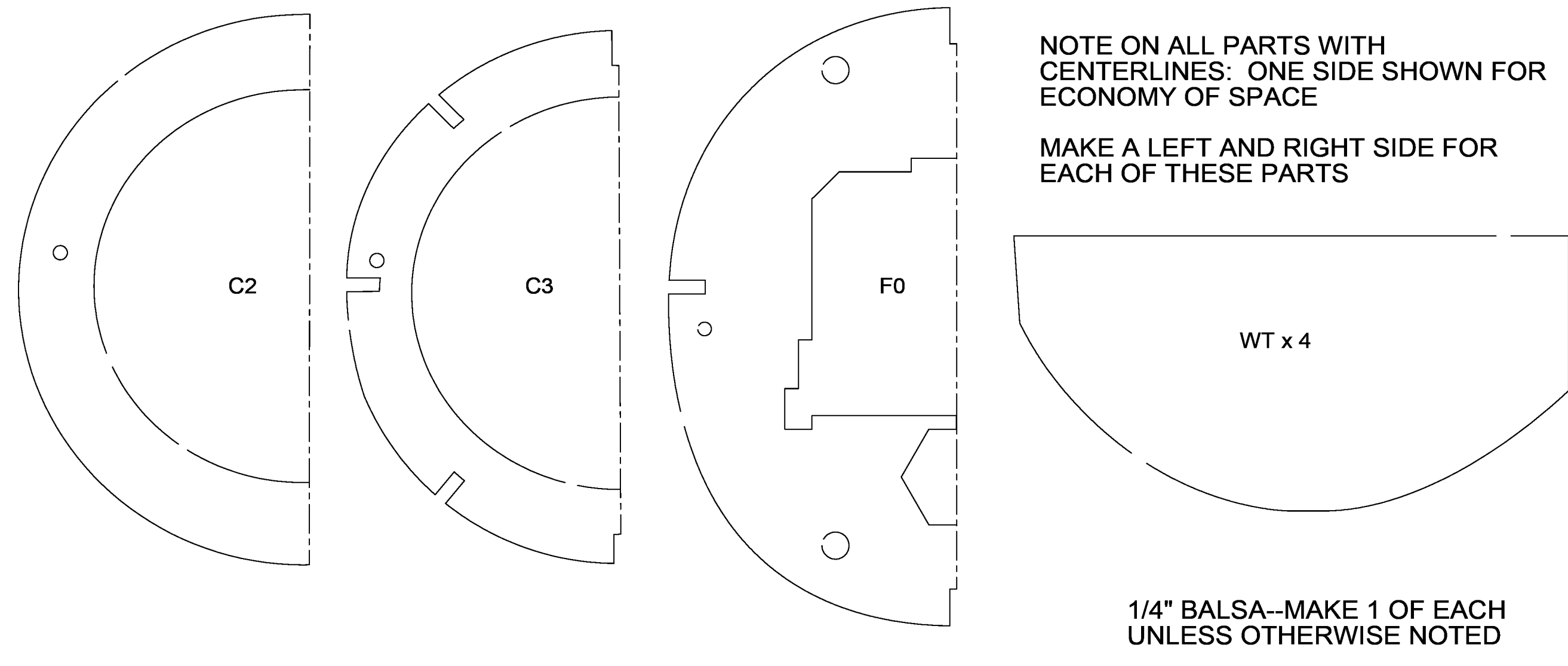

- TAIL GROUP ASSEMBLY--Hstab and Elevators**
- Assembly of the horizontal surfaces is similar to the vertical. Again, ply ribs extend back from the fixed surface into the control surfaces. Please follow the assembly order below for best results.
1. Begin tail group assembly by laminating outlines from three strips of 1/16" x 1/2" balsa around a form.
  2. Pin the cured outlines into place over the plan.
  3. Install the Elevator framework parts in numerical order.
    1. Build the leading edge of the Elevators first.
    2. Parts E3/E14 and E4/E10 form pockets that hinge posts H6 and H7 will fit into later.
    3. Unpin the assembly and cut through the Elevator LE parts E1 and E2 to clear the hinge pockets.
    4. Pin the assembly back down to the board.
  4. Assemble the Horizontal Stabilizer framework parts in order.
    1. Be careful not to glue H6 or H7 to the elevator hinge pockets.
  5. Separate the Elevators from the Hstab by cutting through the outlines where shown.
  6. Sheet the upper Hstab with 1/16" balsa while pinned flat to the board.
  7. Unpin and remove the support feet from the bottom of the Hstab and sheet the bottom side.
  8. Sand to shape.
  9. Hinges--drill through E3/H7/E3 and E4/H6/E4 and pin.
    1. Add standard hinge where shown for additional strength.

Plan No. 1118

INFIELD ENGINEERING by Paul Kohlmann

Copyright 2019 AMA and ModelAviation

Copying for resale of this drawing without the written approval or consent of AMA is expressly prohibited.

Title		60" Douglas TBD Devastator	
Size	Dwg. No.	Rev	
X	Douglas Devastator	A	
Scale: 1:1		Weight: 75oz	Sheet 3 of 4

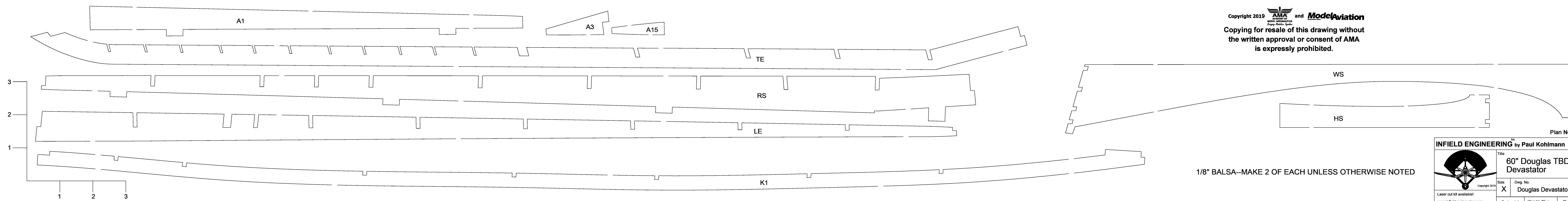
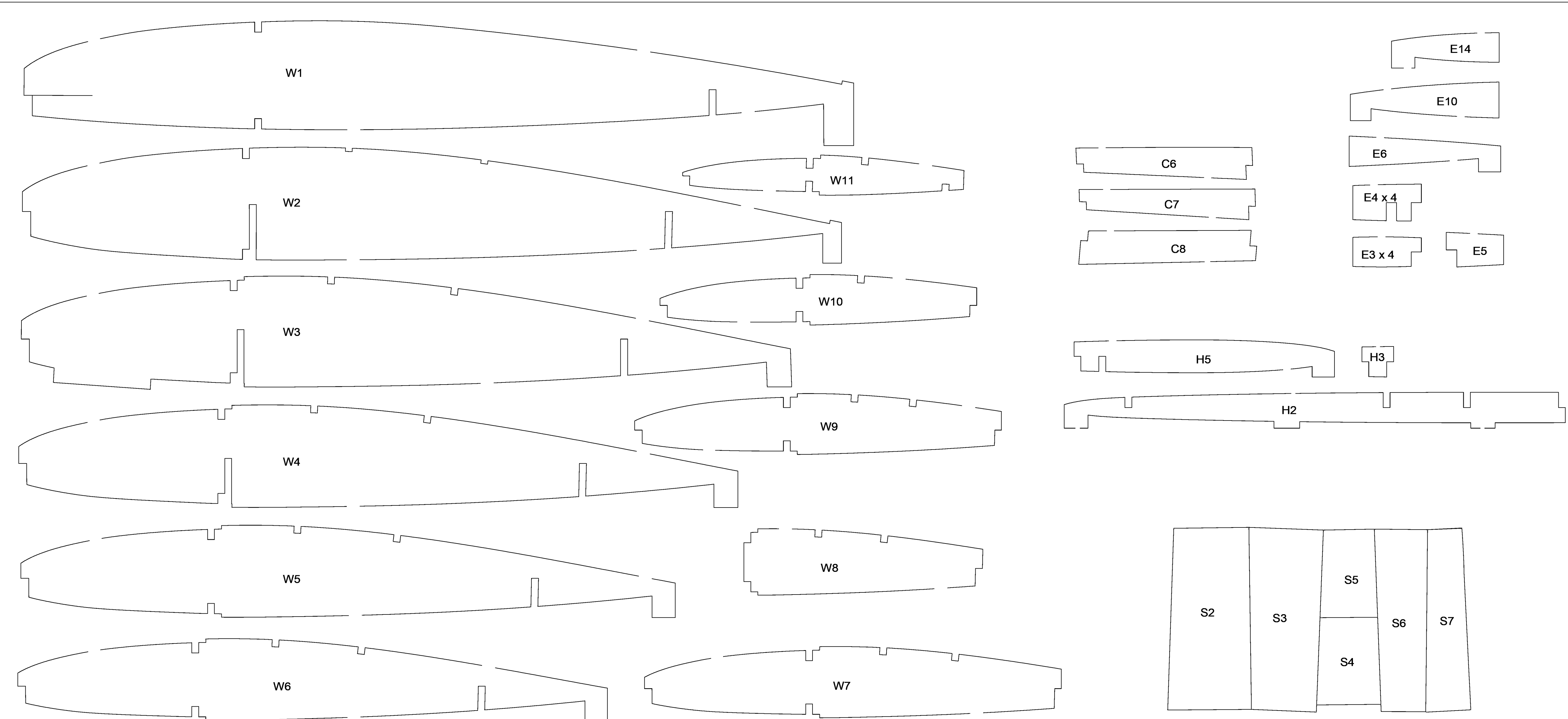
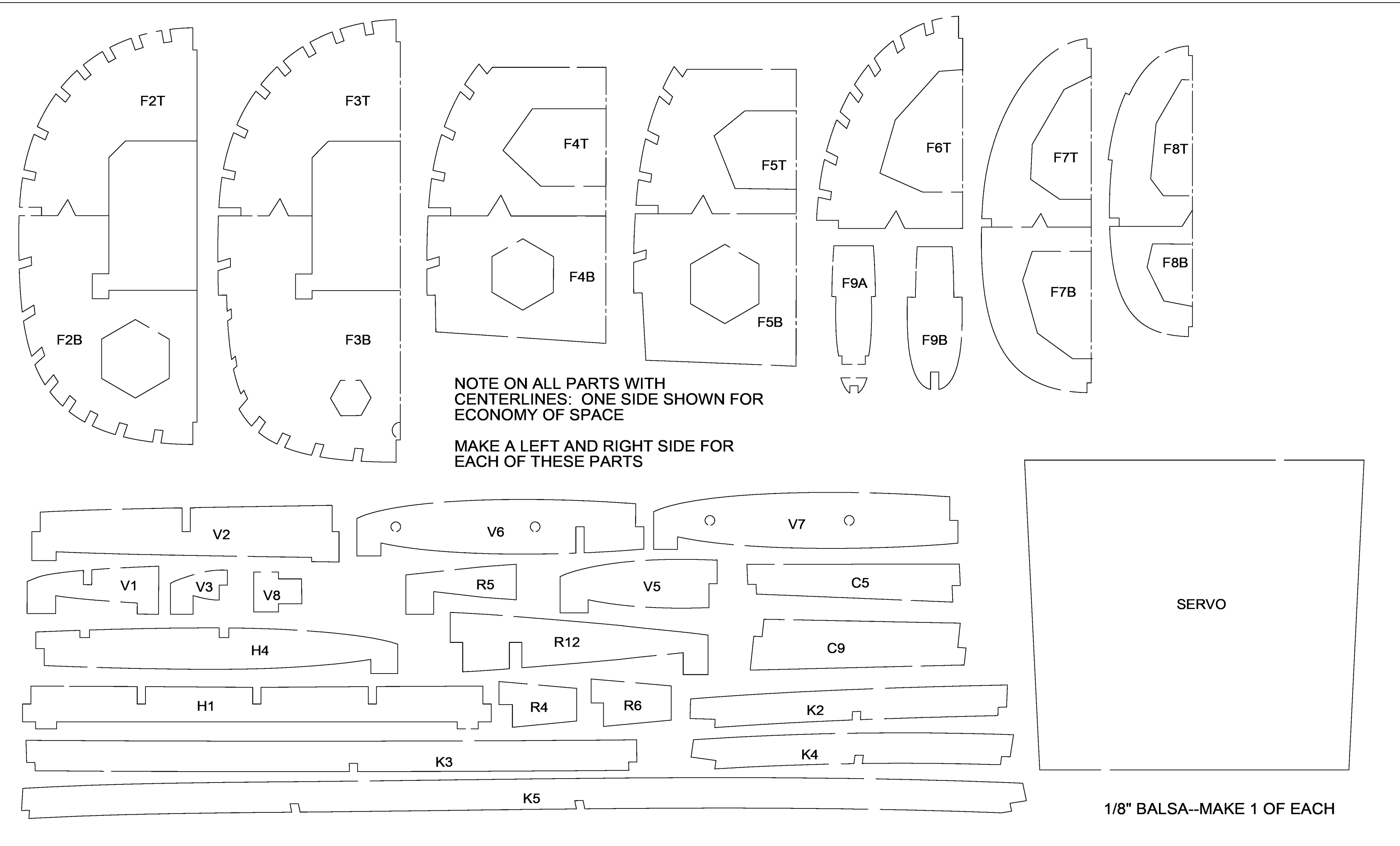

Copyright 2019  and **ModelAviation**  
 Copying for resale of this drawing without the written approval or consent of AMA is expressly prohibited.

1/8" Balsa--MAKE 2 OF EACH UNLESS OTHERWISE NOTED

Plan No. 1118

**INFIELD ENGINEERING** by Paul Kohlmann

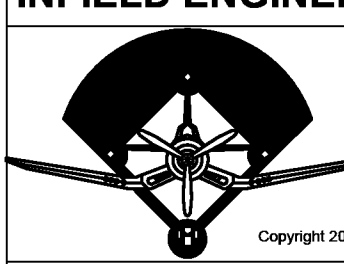

Title: **60" Douglas TBD Devastator**

Size: X	Dwg. No.: Douglas Devastator	Rev: A
Scale: 1:1		Weight: 75oz
Sheet 4 of 4		

www.infieldengineering.com