

Stand-Off Scale

# HIPERBIPE MODEL SNS-7

## MASTER KIT

6 FOX ROAD  
PLAINVILLE, CT.

WINGSPANS: 42 INCHES  
WEIGHT: 4 1/2 - 5 LBS  
POWER: 40 - 60  
DESIGNED & DRAWN BY  
*Frank Massa*  
INKED BY  
*Bob Wallace*

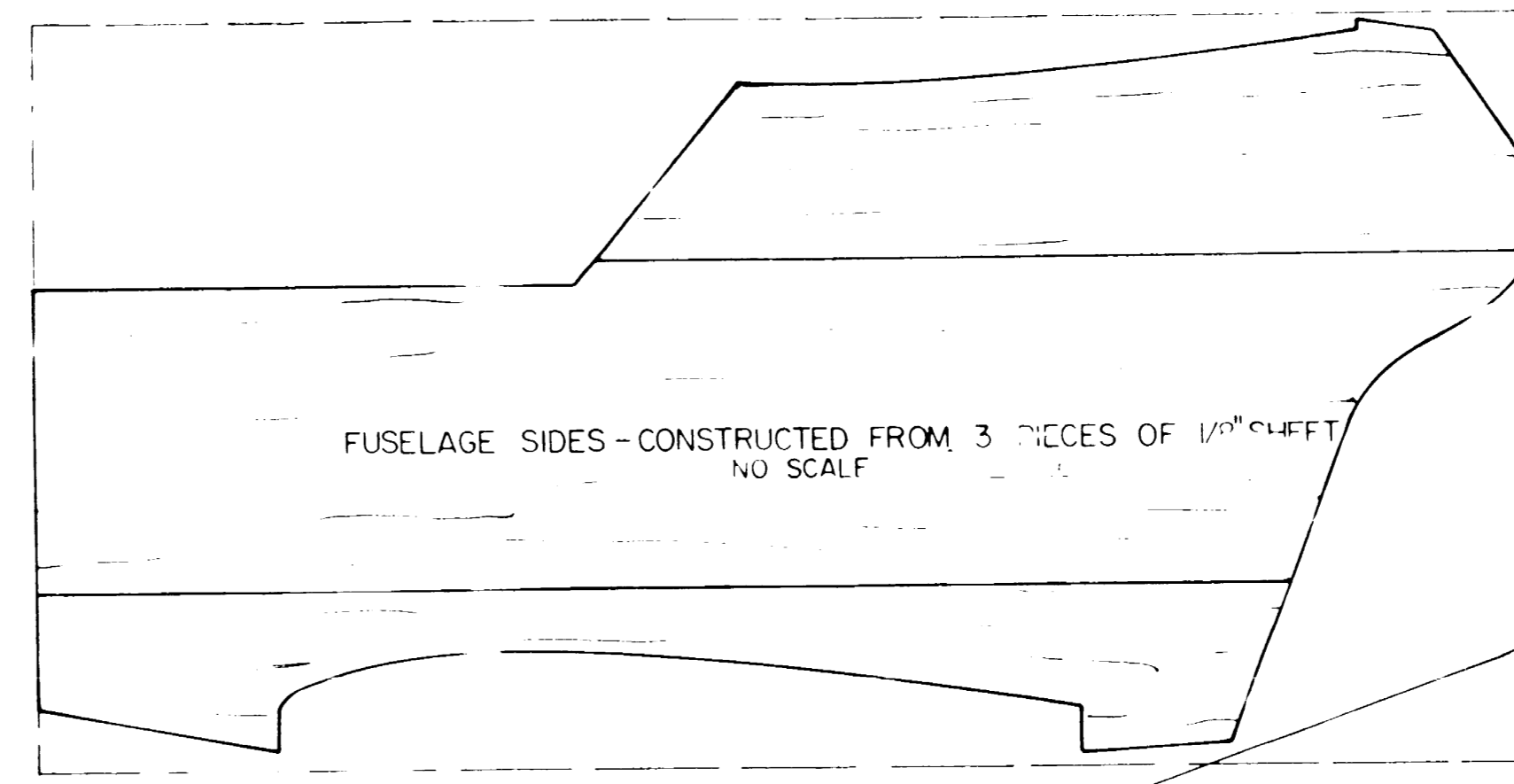
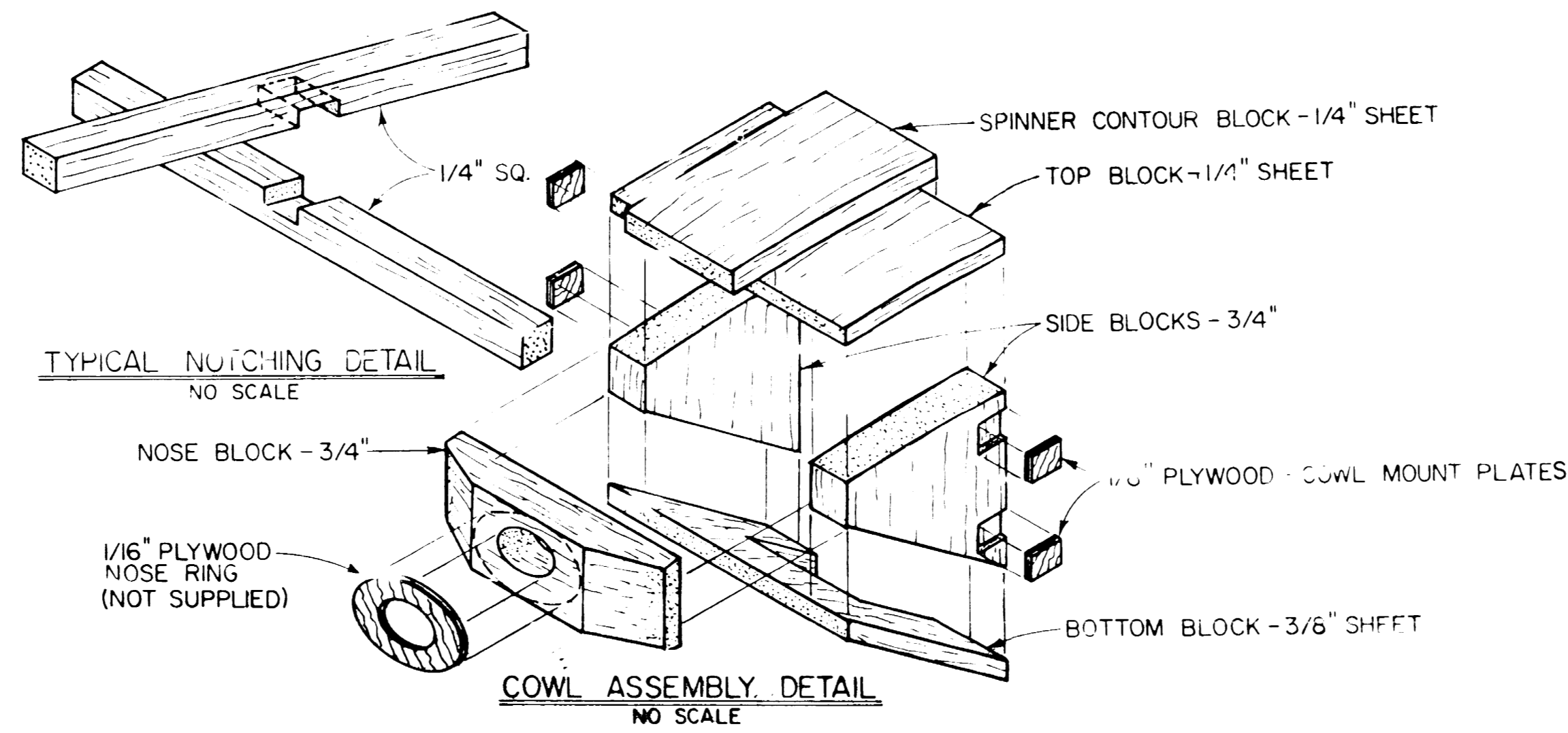
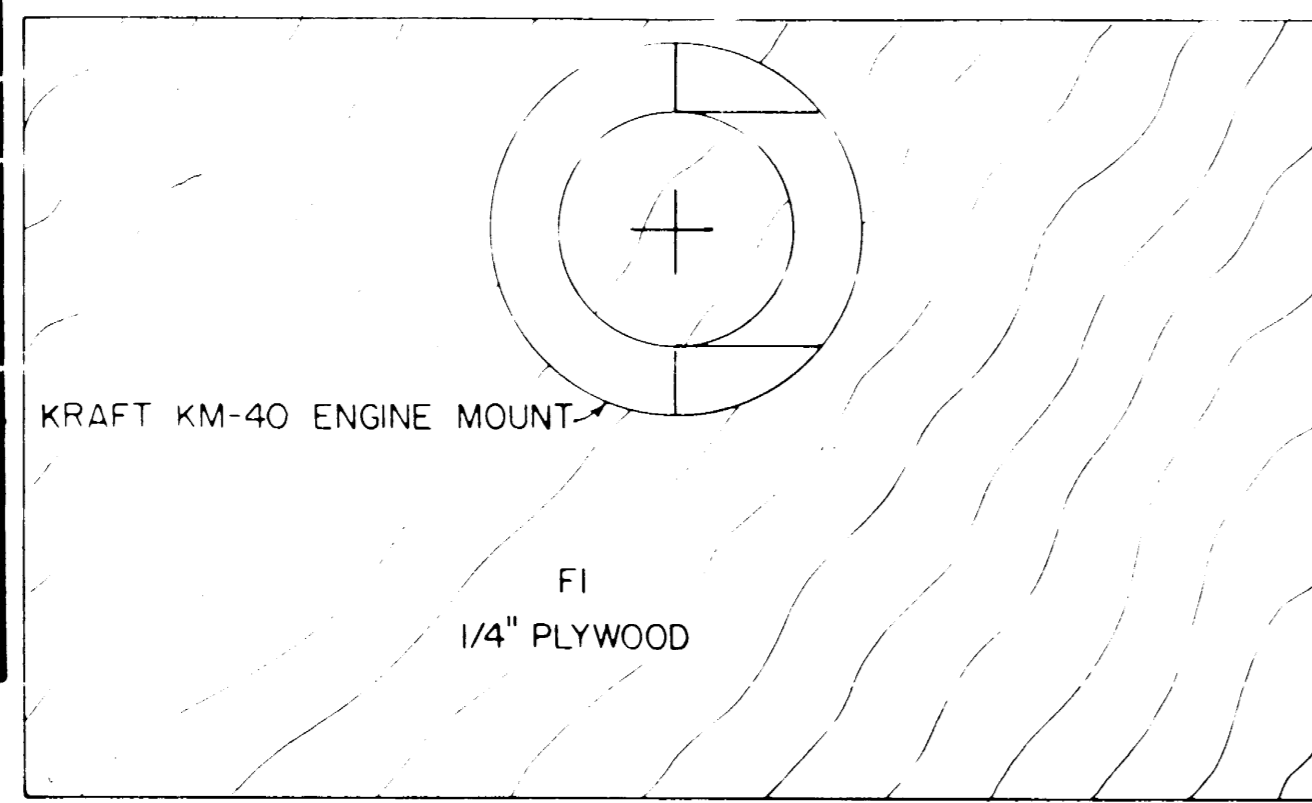

SEE SHEET 2 FOR STABILIZER/  
ELEVATOR DETAILS

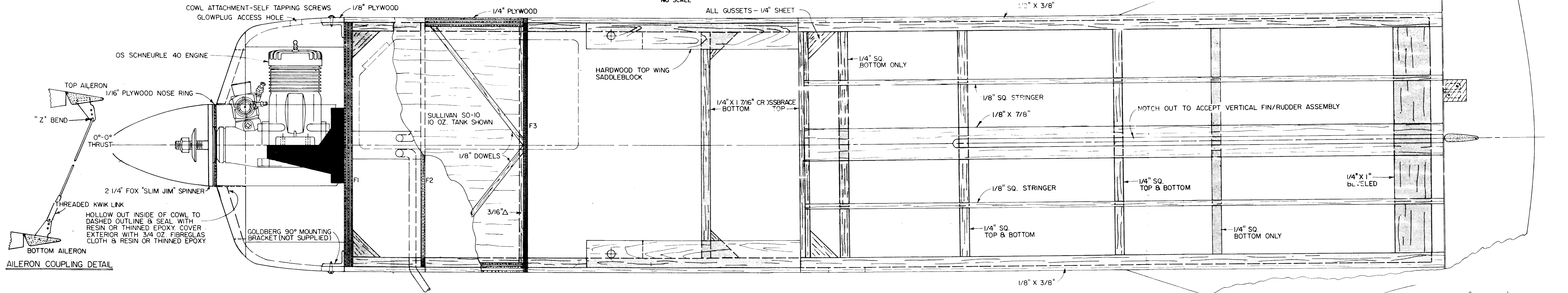

AILERON COUPLING DETAIL

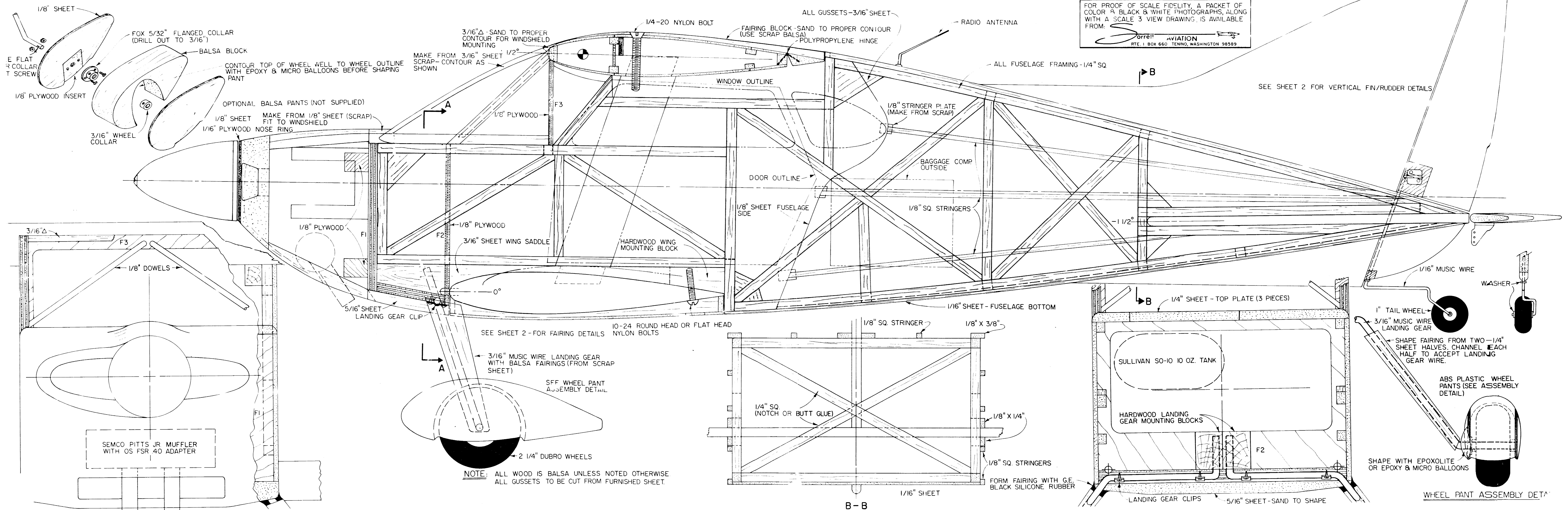

FOR PROOF OF SCALE FIDELITY, A PACKET OF  
COLOR & BLACK & WHITE PHOTOGRAPHS, ALONG  
WITH A SCALE 3 VIEW DRAWING IS AVAILABLE  
FROM:  
**Sorrell AVIATION**  
RTE. 1 BOX 660 TENING, WASHINGTON 98589

SEE SHEET 2 FOR VERTICAL FIN/RUDDER DETAILS

NOTE: ALL WOOD IS BALSA UNLESS NOTED OTHERWISE  
ALL GUSSETS TO BE CUT FROM FURNISHED SHEET

WHEEL PANT ASSEMBLY DETAIL

