

DESIGNED & DRAWN BY
FRED W. SALMON

TRACED & INKED BY
PAUL PLECAN

DETAILED PLANS FOR
"A-B" CLASS VERSION OF
THIS DESIGN APPEAR
IN 1962 AMERICAN
MODELER "ANNUAL".

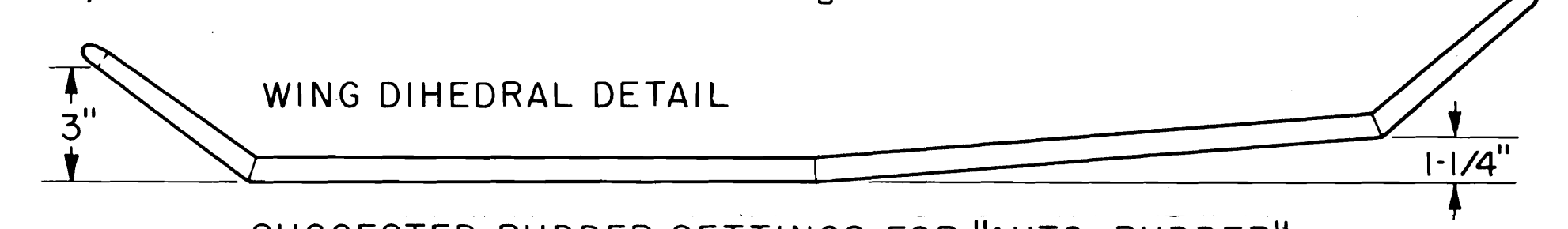
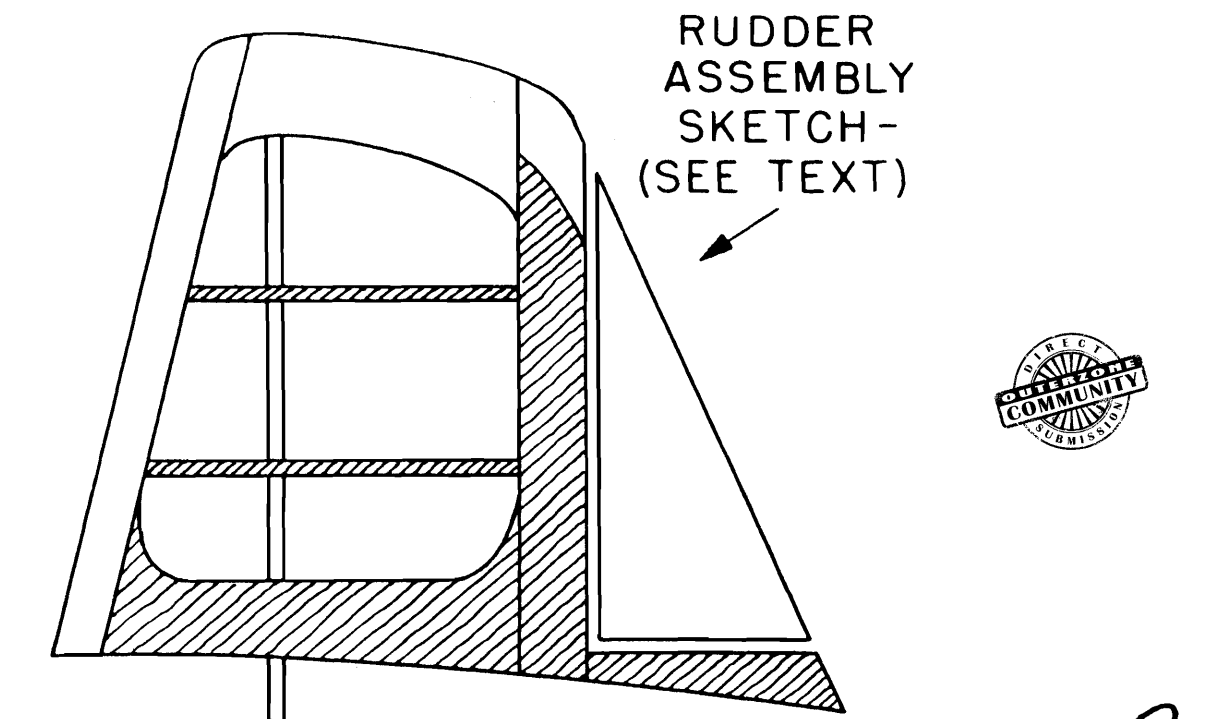
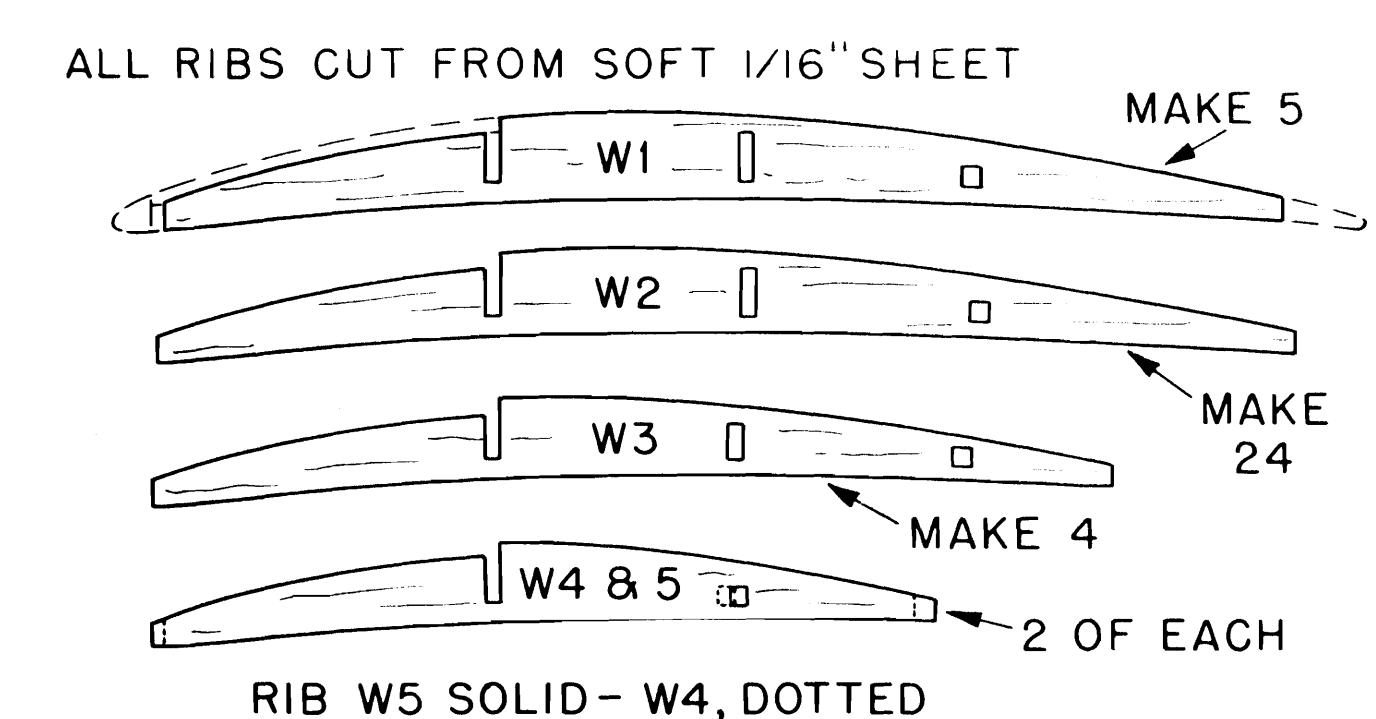

SUGGESTED RUDDER SETTINGS FOR "AUTO-RUDDER"—
POWER: 0°-0° TO 2° LEFT. GLIDE: 10° RIGHT. THIS SHOULD
GIVE A VERY SLIGHT RIGHT TURN UNDER POWER, FAIRLY
LARGE CIRCLES IN GLIDE. IF NOT, RE-ADJUST ACCORDINGLY.

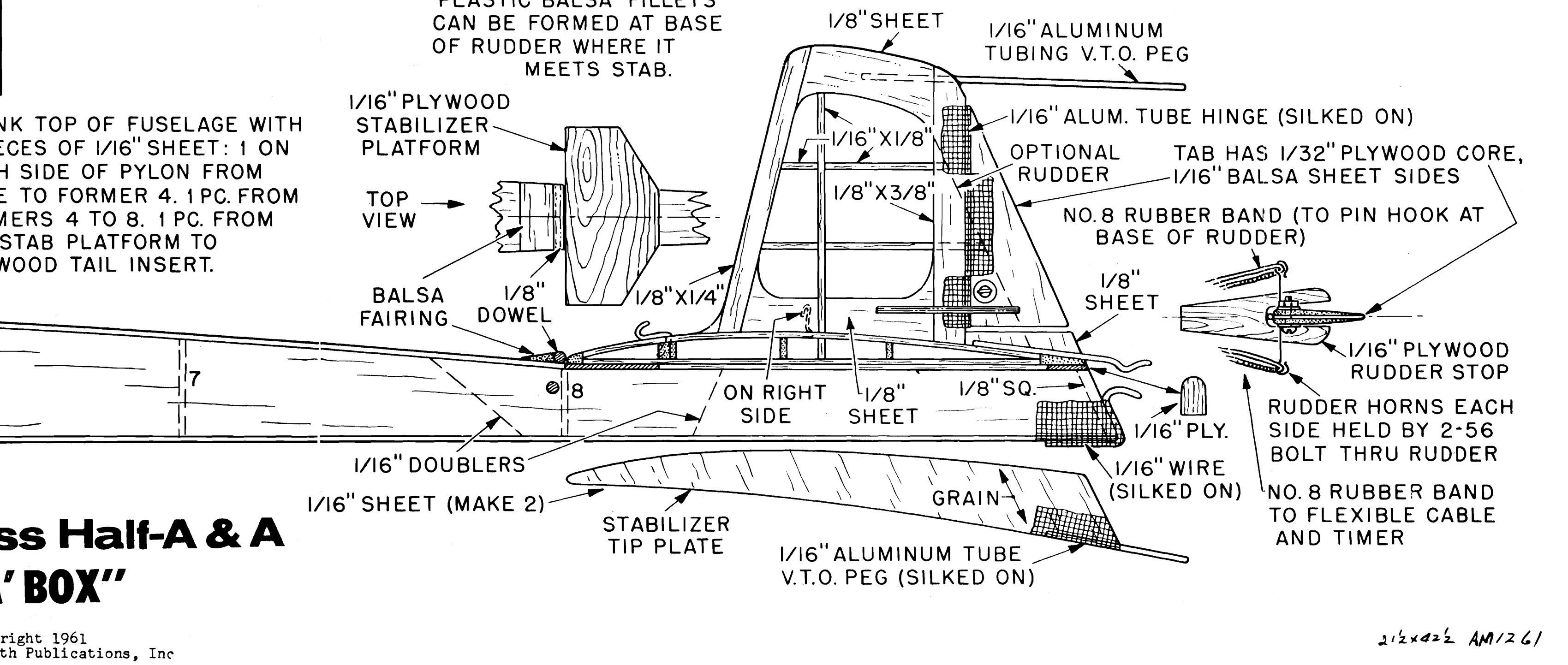
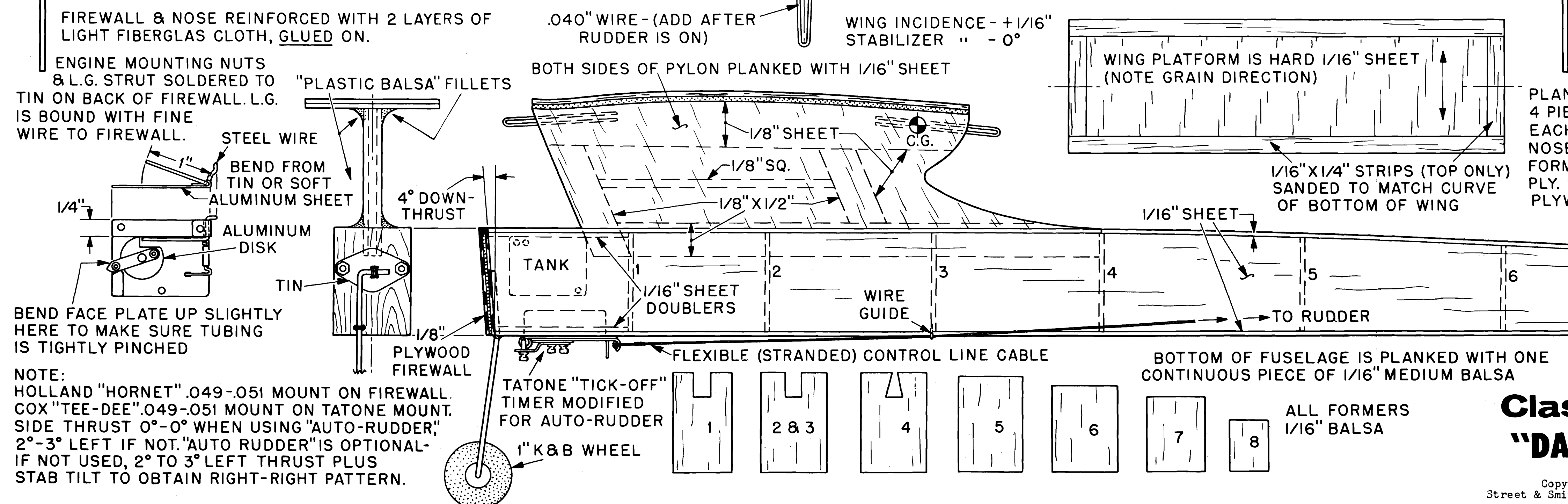

Class Half-A & A "DA' BOX"