

PROPELLER  
 $\frac{3}{4} \times 1\frac{1}{8} \times 7$ " Balsa

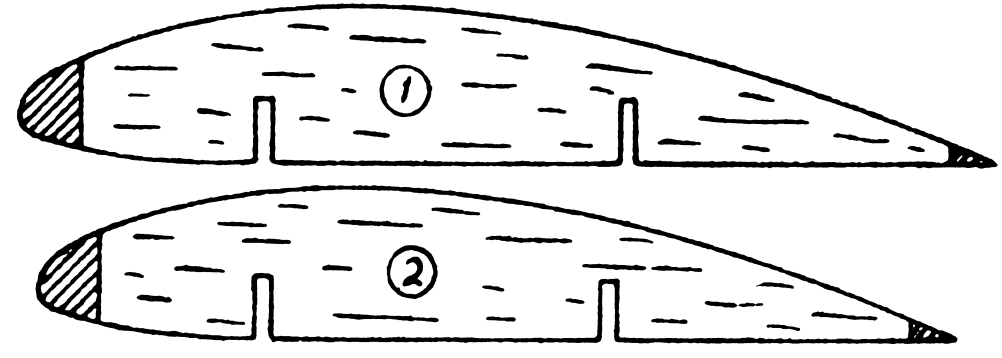

RIBS 1 and 2  $\frac{1}{8}$ " SHEET Balsa 2 REQ'D. OF EACH

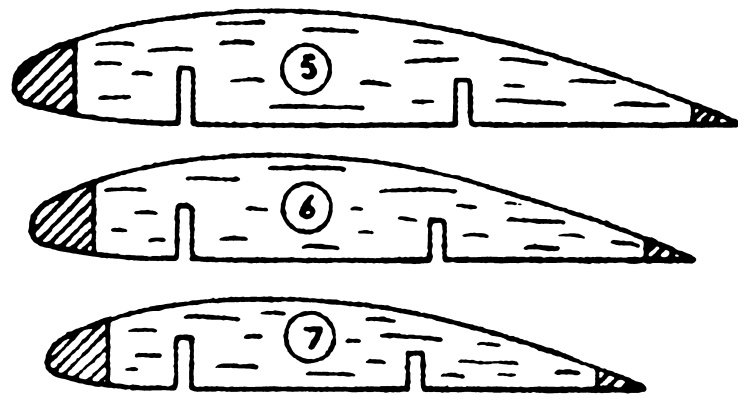

RIBS 3-4-5-6-7 and 8  $\frac{1}{8}$ " SHEET Balsa 2 REQUIRED OF EACH

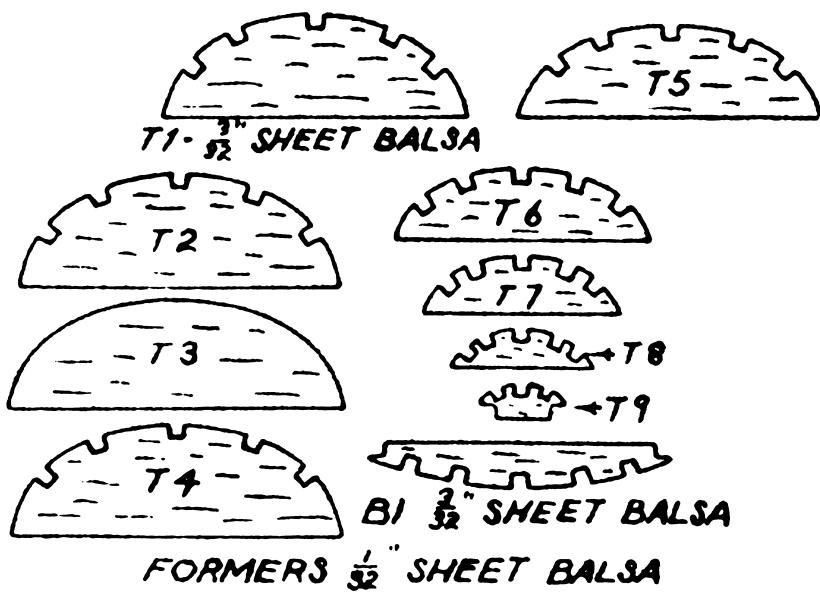

FORMERS  $\frac{1}{8}$ " SHEET Balsa

**Bill of Materials**

- Eight strips  $\frac{1}{16}$ " hard balsa for longerons, stringers, etc.;
- Two pieces  $\frac{1}{4}$ " by  $\frac{3}{4}$ " by 10" balsa for leading edge spars;
- Two pieces  $\frac{1}{16}$ " by  $\frac{3}{16}$ " by 9 $\frac{1}{4}$ " balsa for trailing edge spars;
- Four pieces  $\frac{1}{16}$ " by  $\frac{1}{4}$ " by 9 $\frac{1}{2}$ " balsa for inter-wing spars;
- One piece  $\frac{1}{16}$ " by 3" by 24" sheet balsa for ribs, tail surface parts, etc.;
- One piece  $\frac{3}{32}$ " sheet balsa for fuselage formers;
- Two pieces  $\frac{1}{4}$ " by  $\frac{3}{4}$ " by 3 $\frac{1}{2}$ " balsa for stub wings;
- One piece  $\frac{1}{16}$ " by 1-3/16" by 1 $\frac{1}{2}$ " balsa for nose block;
- One piece  $\frac{15}{32}$ " by 1 $\frac{1}{4}$ " by 1 $\frac{1}{4}$ " balsa for nose plug;
- Hard balsa pieces for landing gear;
- Rubber or wood wheels, 1 $\frac{1}{2}$ " diameter;
- Sheet celluloid for windshields;
- Sheet balsa for cockpit covers;
- One piece .028 wire for front and rear hooks;
- One piece .020 wire for landing gear shock absorbers;
- One sheet fine jap tissue;
- Banana oil, cement, small pins.

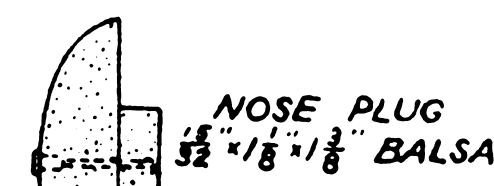
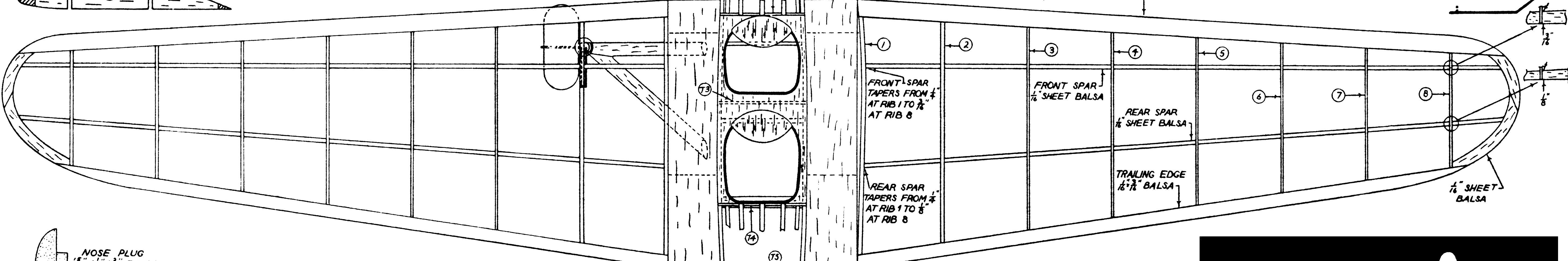
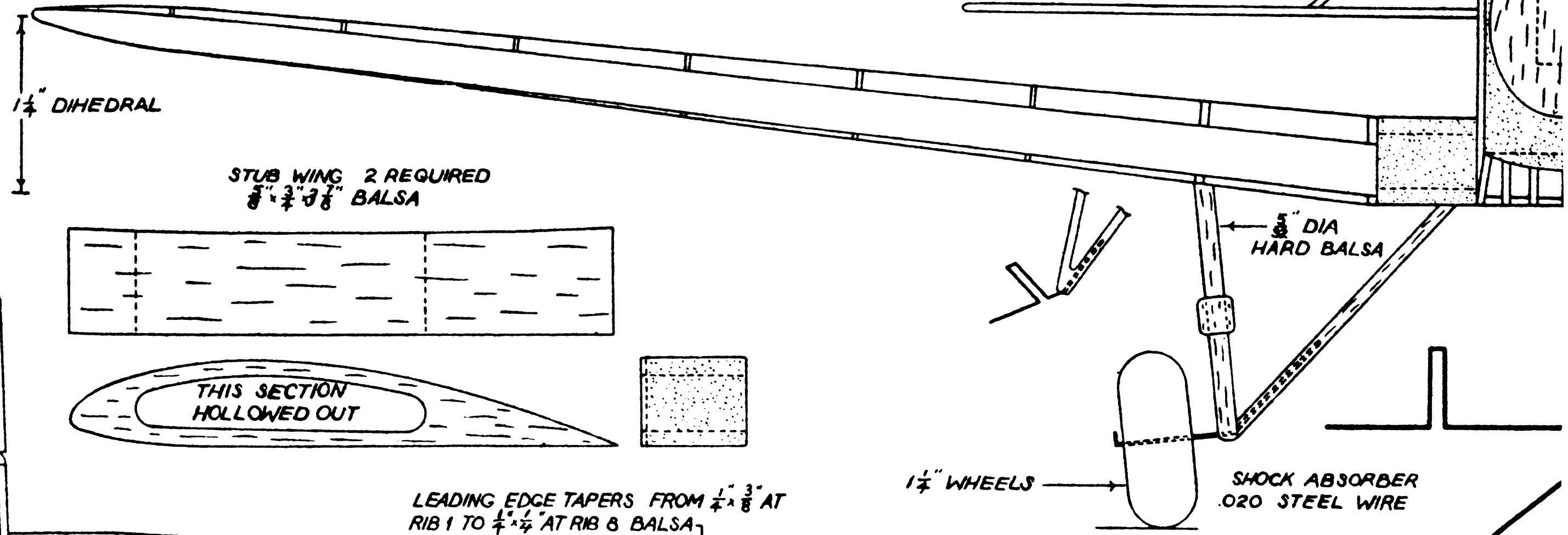

NOSE PLUG  
 $\frac{1}{2} \times 1\frac{1}{8} \times 1\frac{3}{8}$ " Balsa

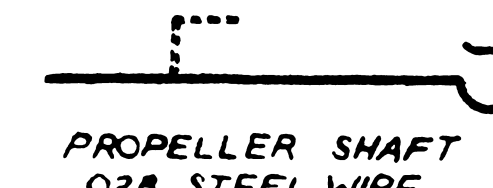

PROPELLER SHAFT  
 .028 STEEL WIRE

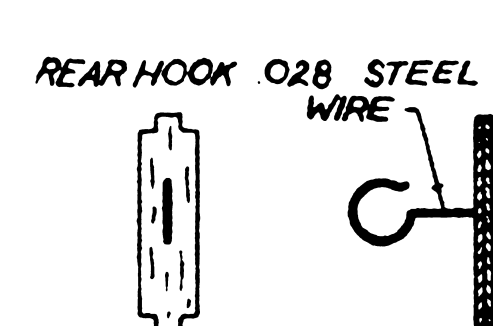

REAR HOOK .028 STEEL WIRE

F1 - 2 SHEETS  $\frac{1}{8}$ " SHEET Balsa LAMINATED CROSS-GRAIN

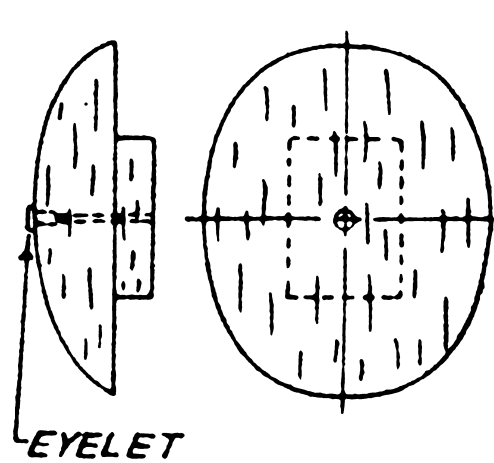

EYELET

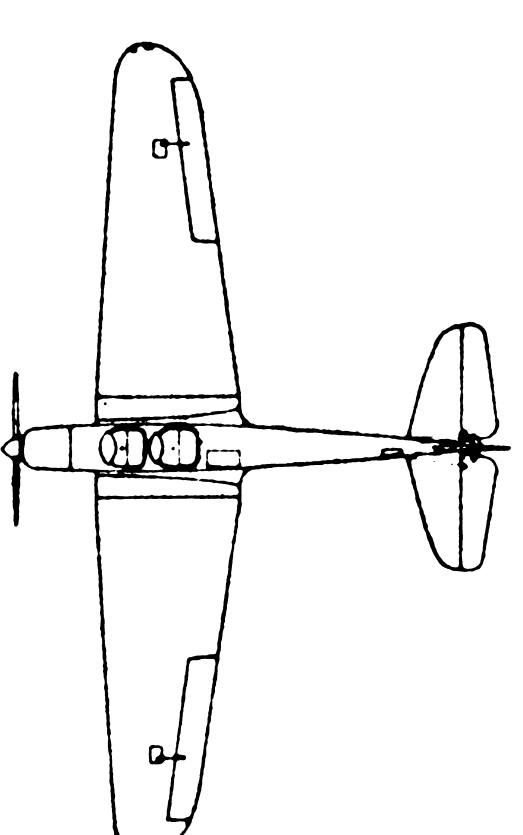

HORACE KEANE  
 FORD V-8

1 1/2" RUBBER OR HARD-WOOD WHEELS

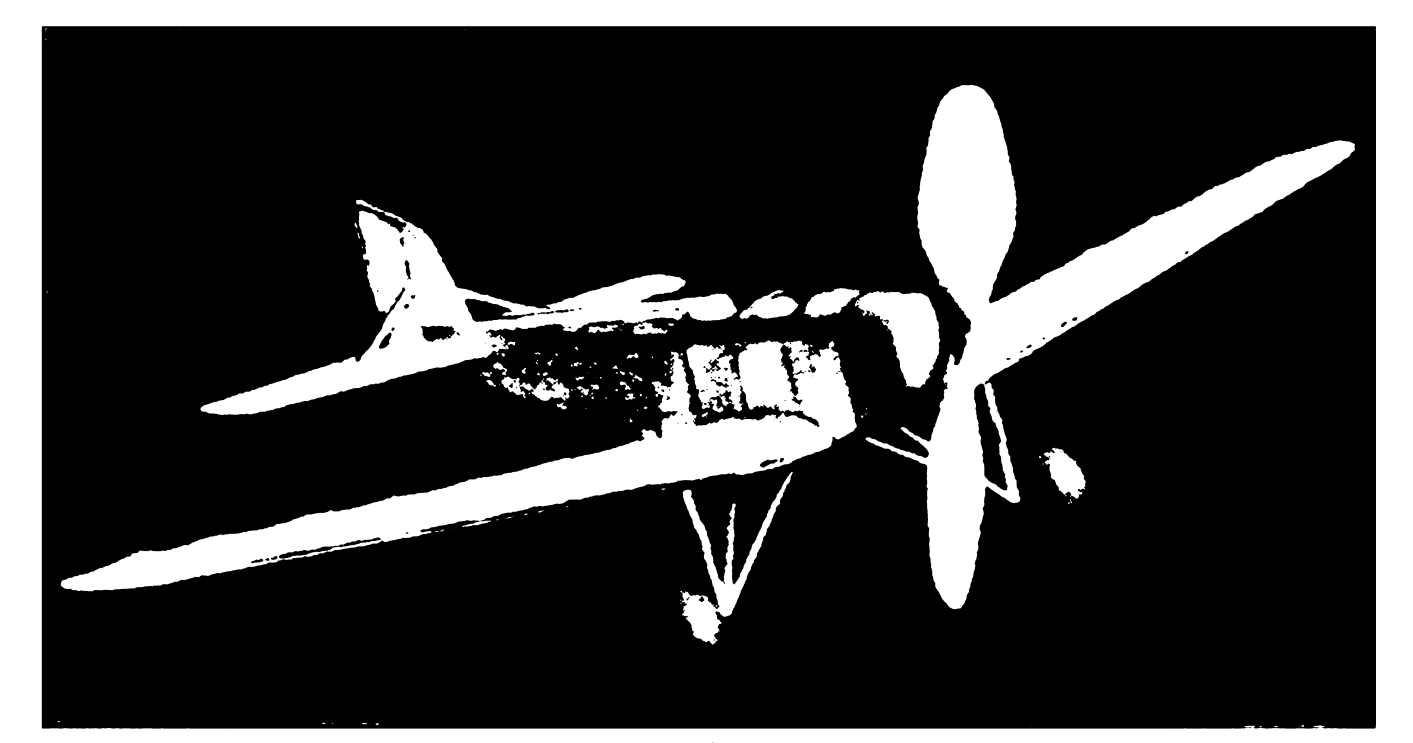
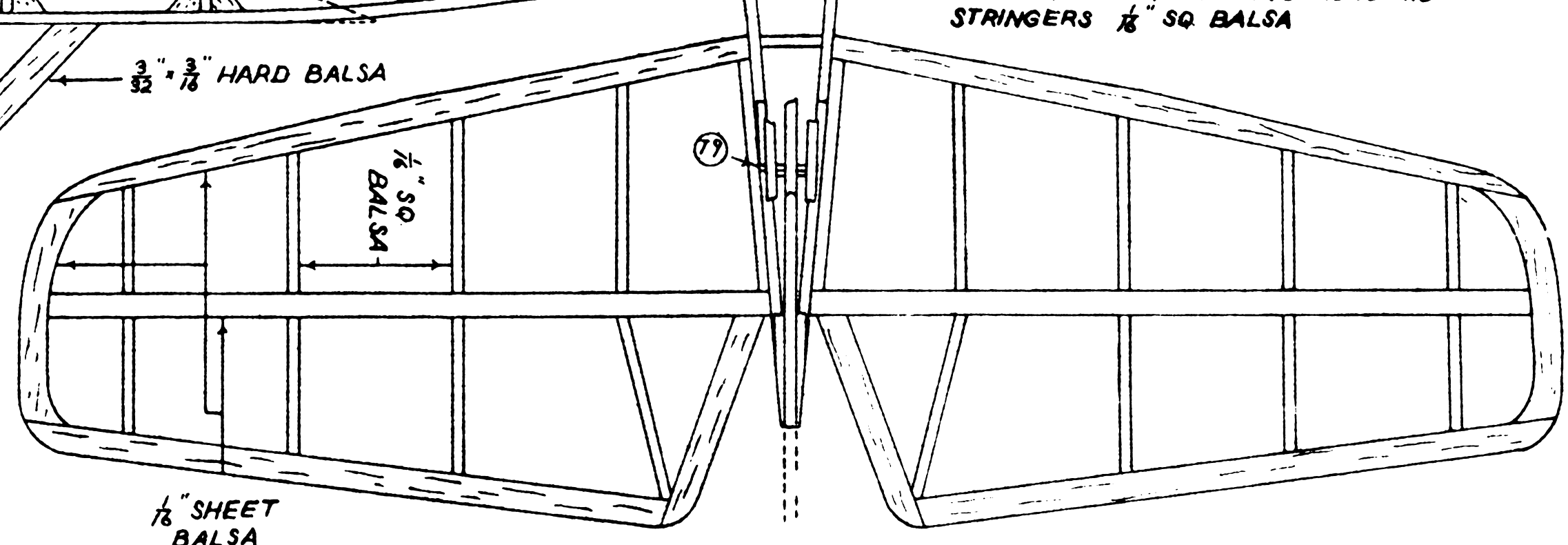

This excellent front quarter view gives a good idea of the amount of fine hand work with the Keane Ace plane. This low wing model isn't hard to build, and you'll find that she flies even better than she looks.

**T**HE Horace Keane ace has a wing span of 36 feet, 8 inches, and an overall length of 23 feet, 4 inches. Its maximum speed is 112 m.p.h. and it cruises at 94 very economically. It lands at 47, has a rate of climb of 600 feet per minute and can cruise 300 miles. Ford V-8 engine

GOLDEN AGE REPRODUCTIONS

# Keane Ace

By Jesse Davidson  
 FLYING ACES JUNE '37'

Dwg. 114

Bill Hovey ORG 73