

CUT BODY STRIPES FROM PLAN AND CEMENT TO FINISHED MODEL

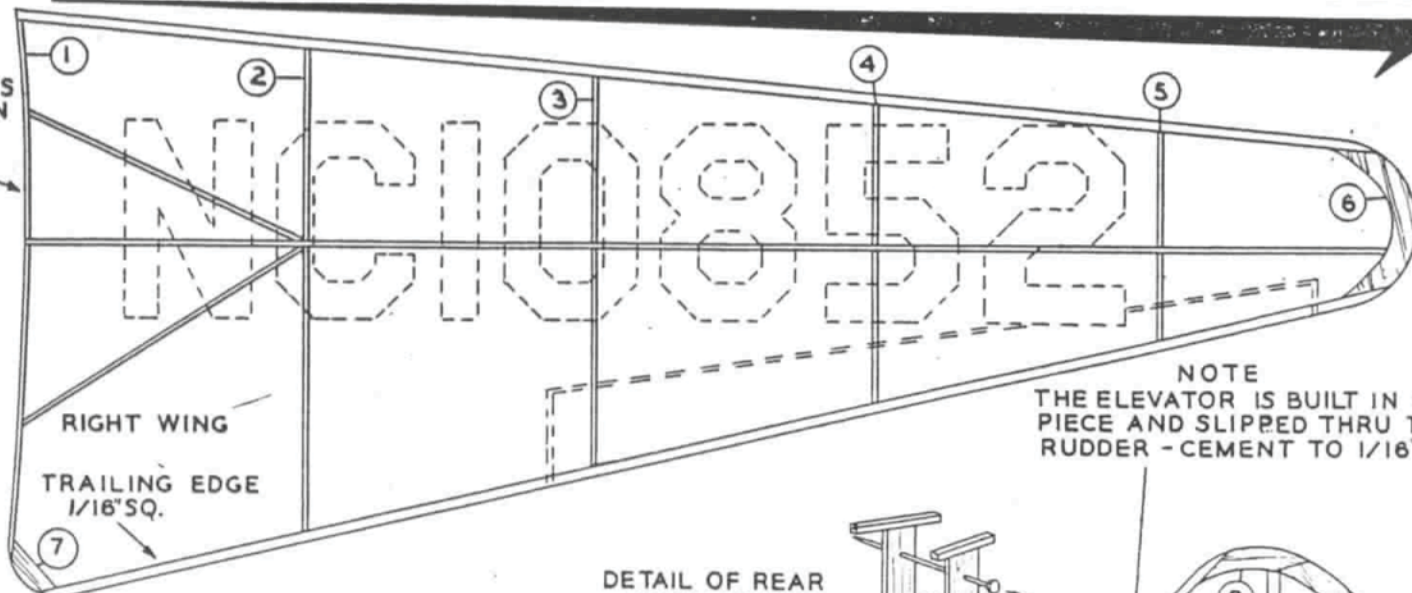
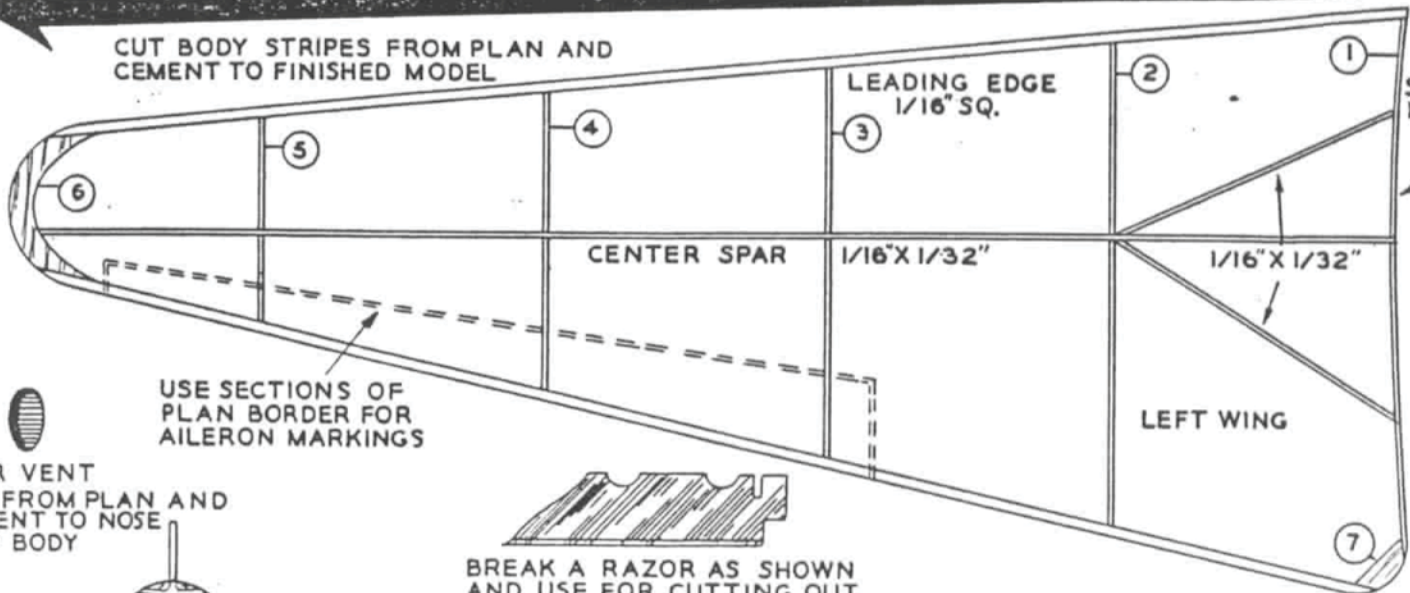

NOTE  
THE ELEVATOR IS BUILT IN ONE  
PIECE AND SLIPPED THRU THE  
RUDDER - CEMENT TO 1/16\"/>

USE SECTIONS OF  
PLAN BORDER FOR  
AILERON MARKINGS

AIR VENT  
CUT FROM PLAN AND  
CEMENT TO NOSE  
OF BODY

BREAK A RAZOR AS SHOWN  
AND USE FOR CUTTING OUT  
THE SMALL BALSA PARTS

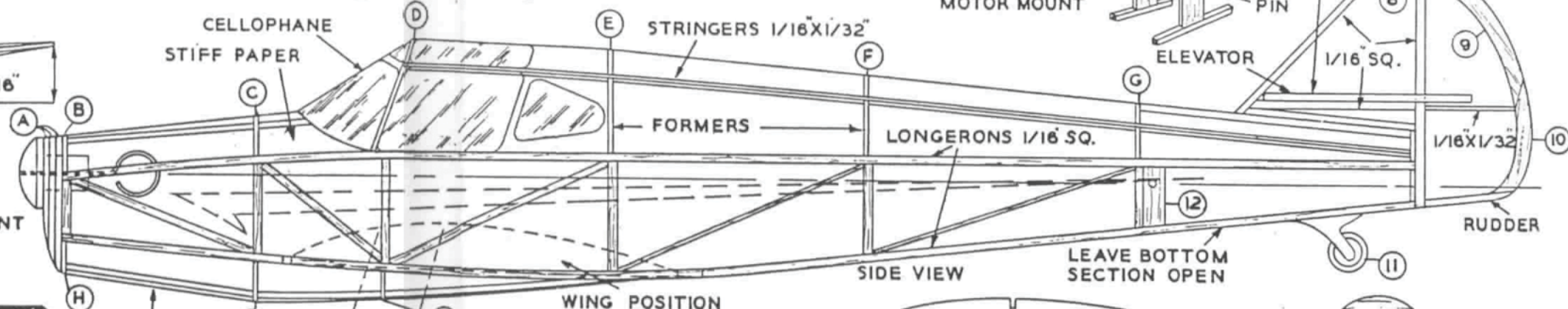
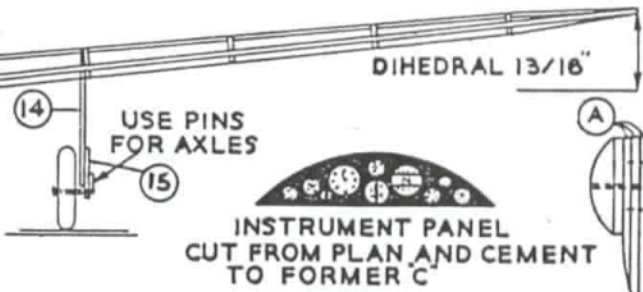
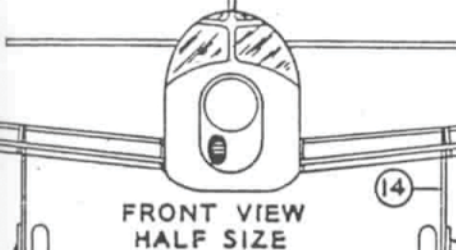

DETAIL OF REAR  
MOTOR MOUNT

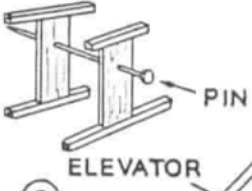

CUT LICENSE NUMERALS FROM PLAN AND  
CEMENT TO TOP SIDE OF RIGHT WING

# NC10852

ENTIRE NOSE OF BODY  
BETWEEN FORMERS  
B AND C IS  
COVERED WITH  
STIFF PAPER

- NOTE -  
DO NOT CEMENT NOSE  
PLUG IN PLACE  
COVER WINGS AND ELEVATOR  
ON TOP SIDE ONLY - RUDDER  
ON LEFT SIDE ONLY  
CUT LONGEST LENGTHS OF  
1/16\"/>

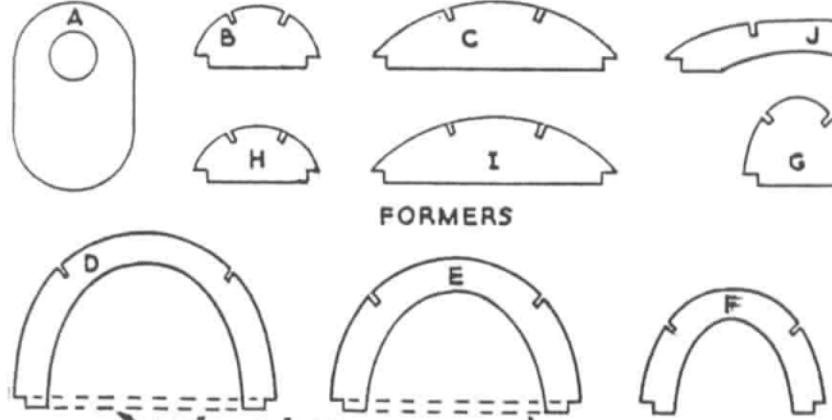
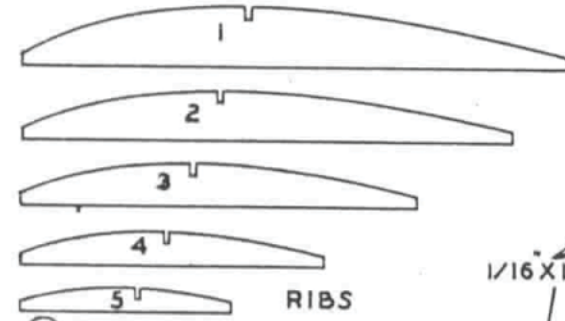

FORMERS

1/16\"/>

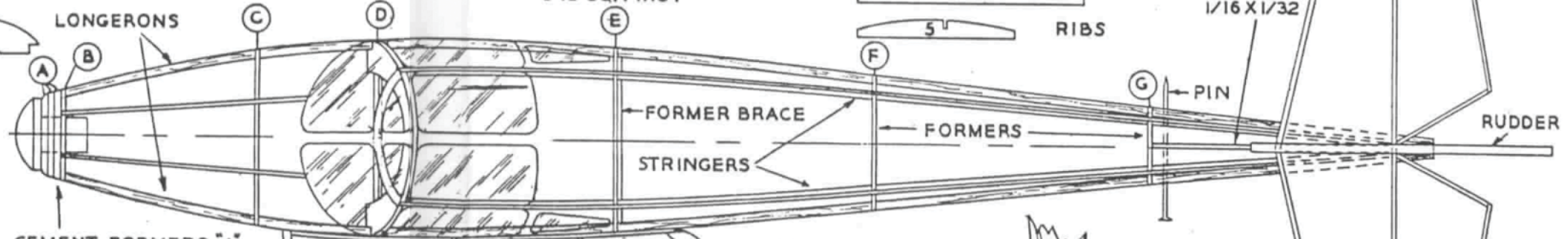

CEMENT FORMERS "A"  
TOGETHER AND SAND-  
PAPER TO SHAPE SHOWN  
IN TOP AND SIDE VIEWS

TOP VIEW

DETAIL OF PROP  
AND SHAFT ASSEMBLY

BEND END OF PROP SHAFT  
AS SHOWN AND FORCE  
BACK INTO PROP

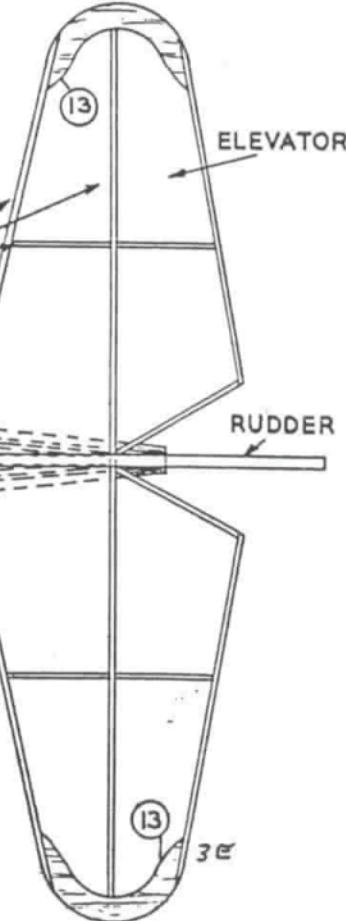
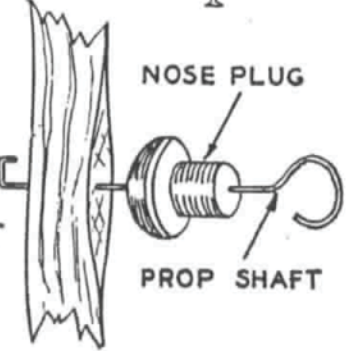

3e

NO. F74  
RYAN SC  
PAUL K. GUILLOW - - - WAKEFIELD, MASS.

COPYRIGHT 1939 P.K.G.