

Guillow's

KIT DC-30

MESSERSCHMITT WORLD WAR 2 FLYING MODEL

With the outbreak of World War 2, the Messerschmitt Me-109 played a prime part in destroying Polish and French air resistance. Until the advent of the British Spitfire, the Me-109 was unmatched in speed, maneuverability and fire power.

First carefully remove all die-cut parts from balsa sheets. Lay parts on a workboard with numbers up for quick identification. Use model cement for assembling your model. This is obtainable at your local hobby dealer or chain store.

ASSEMBLING THE MODEL

1. Cement NOSE BRACES F-1 on each side of fuselage nose.
2. Cement wheel sections together with printed side out.
3. Build right and left wing frames as shown on reverse side of this sheet.
4. Cement completed wings to sides of fuselage — hold until dry.
5. Cement STABILIZER to fuselage tail — then add RUDDER.
6. Cut wheel struts to length and assemble struts and wheels as shown below.
7. Cement landing gear to wing — let cement dry solid — apply 2nd coat.
8. Add TAILWHEEL and stiff paper WHEEL FLAPS.
9. Insert common pin thru the top of fuselage and attach one end of rubber motor.
10. Insert nose bearing in fuselage nose and hook free end of rubber motor over propeller shaft.
11. Add radio mast and aerial as shown.

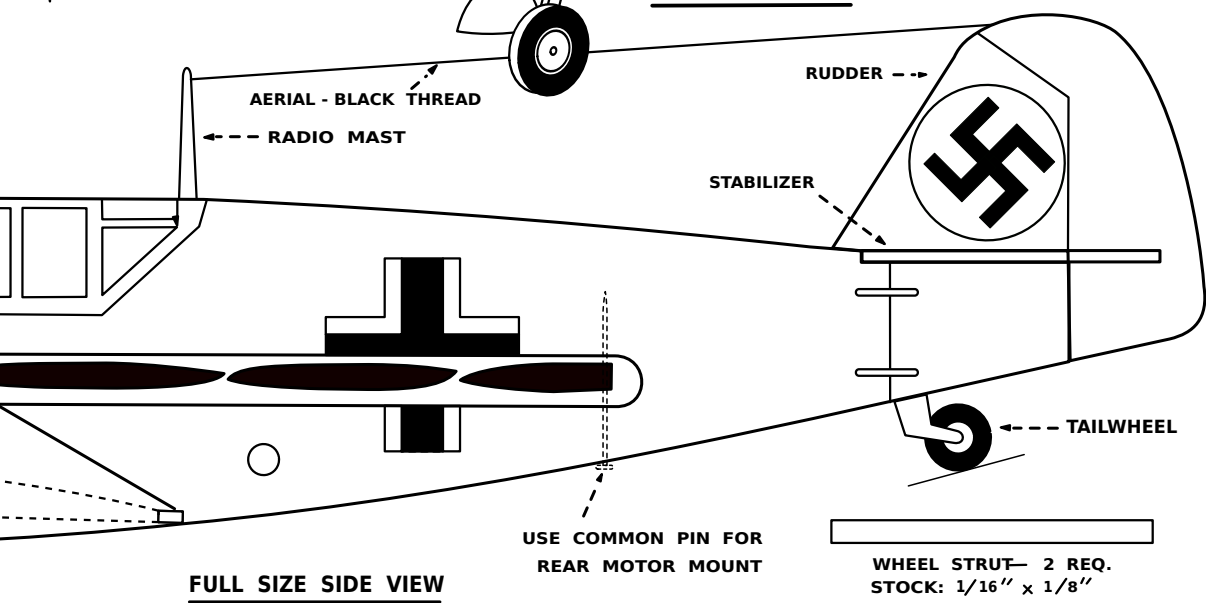
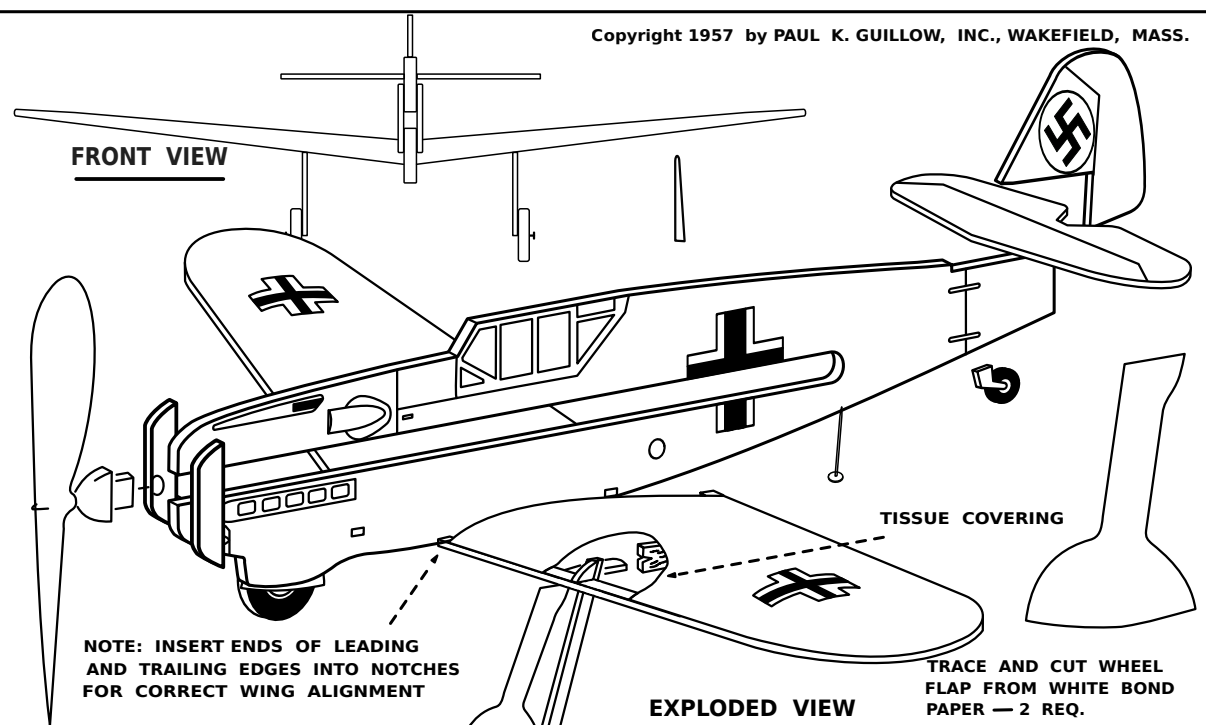
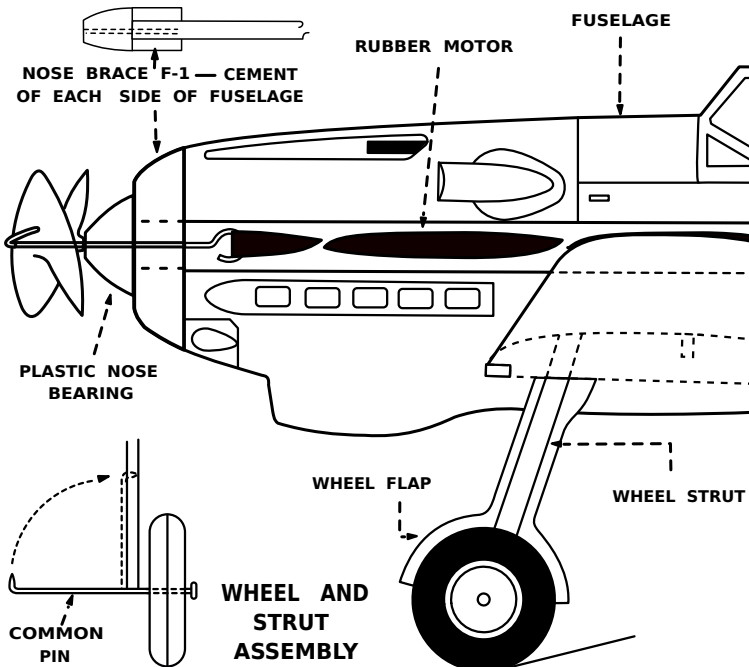

FLIGHT INSTRUCTIONS

Test glide model before making powered flights. Hold model beneath wing and launch gently forward like a glider. If plane noses up into a stall, warp rear edge of stabilizer down slightly do not break. If model dives into

ground, warp stabilizer up.

After proper corrections, wind motor clockwise about 100 to 125 turns and launch straight out. Model can be flown indoors or out. Launch into breeze if flown outdoors. Try R.O.G. flights for added fun.

WING FRAME LAYOUT SHEET

Build wing frames directly over layouts. first lay this sheet on a workboard, then pin a piece of wax paper over layouts to prevent wood parts from sticking to plan during cementing.

BUILDING WING FRAMES

1. Cut LEADING and TRAILING edges to length and pin in place on layouts. (Use common pins-)
2. Cement die-cut WING RIBS to LEADING and TRAILING EDGES. use dihedral gauge W-7 for correct ROOT RIB angle. (A)
3. Cut CENTER SPAR to length and cement in place.
4. Add WING TIP W-5; then STRUT BRACKET W-6.
5. Apply second coat of cement to all joints let dry hard!
6. Remove pins and gently lift frames from wax paper. Trim off excess spar lengths.

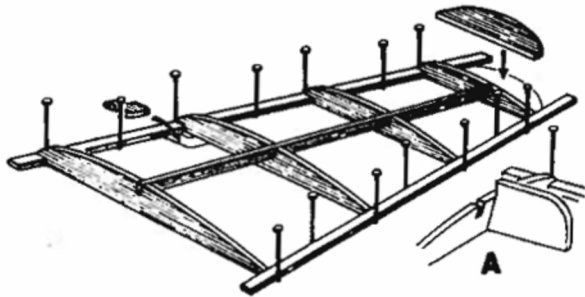

COVERING WING FRAMES

1. Lightly sandpaper frames to remove balsa fuss and any excess cement.
2. Only tops of frames are covered with tissue. First cover area between ribs and leading and trailing edges (B) Only apply cement along front of leading edge and top of ribs and trailing edge as shown.
3. Cover of wing tips separately (C). Trim off excess tissue.

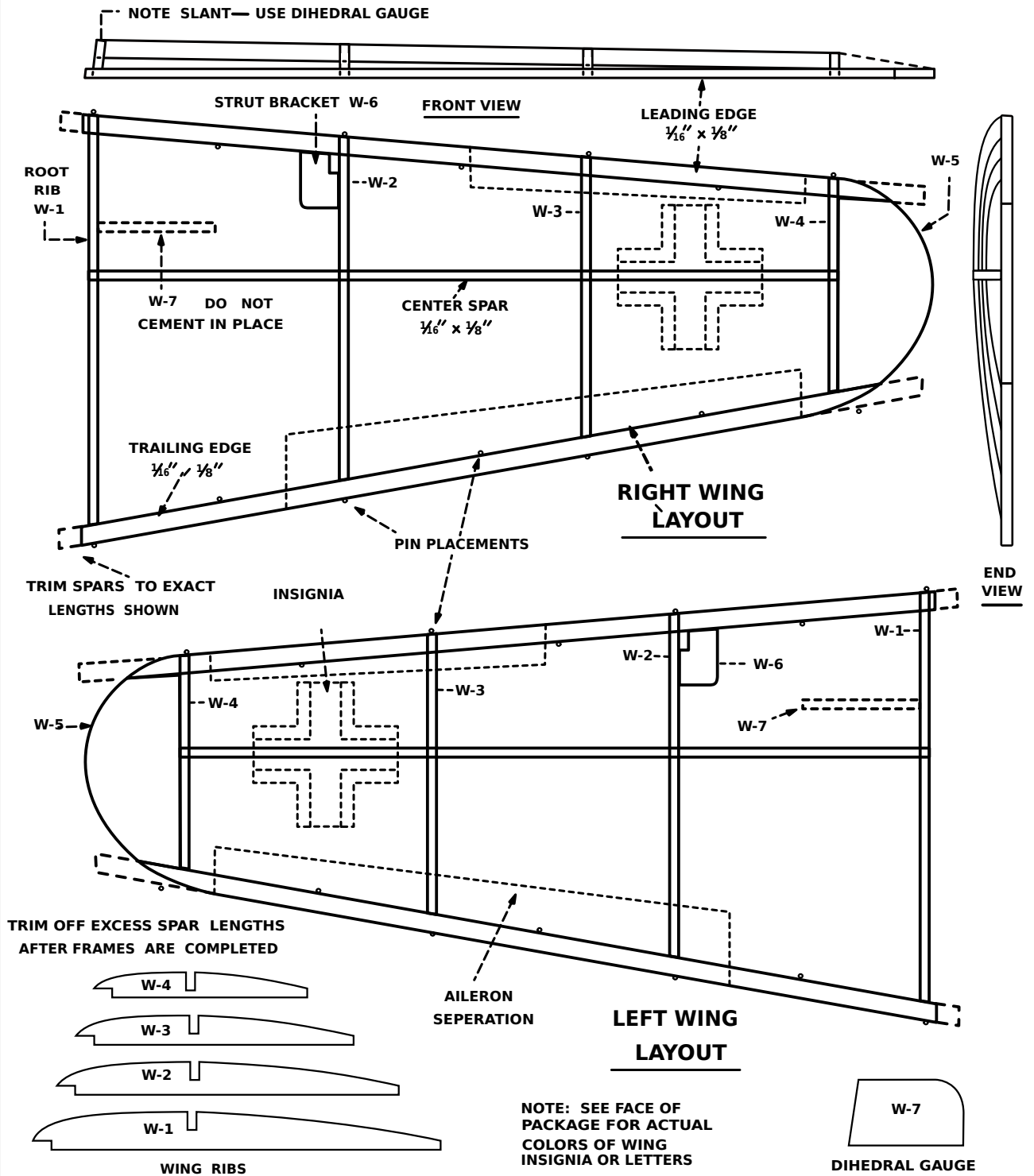
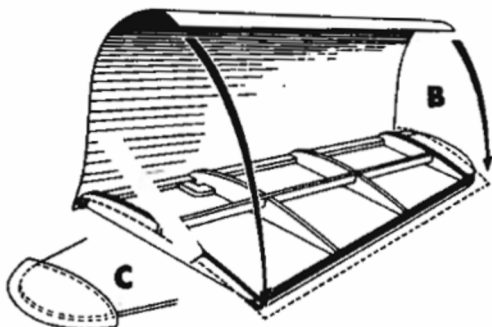

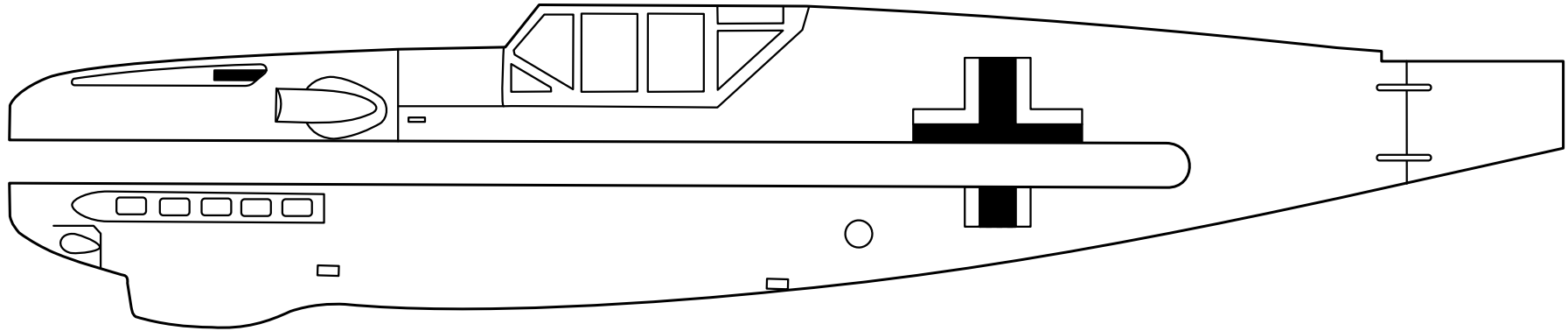

In the kit fuselage were 3/16", the rest 1/16". 3mm for the fuse and 1mm for the rest may be adequate.

