

¡ATENCIÓN! Sujete la carena al fuselaje por medio de 4 tornillos roscas/madera, 2 a cada lado, atornillados en la cuaderna n°4

by four screws, wood-thread, to each side screwed to the former number one.

¡ATENCIÓN! Atachez le nez de l'avion au fuselage au moyen de 4 tourne-visses pour bois, 2 à chaque côté, vissés dans la cuaderne n°4.

ACHTUNG! Festbinden die Schanze zu dem Körper für vier (4) Schrauben, besonders für Holz (breit), Zwei (2) jede Seite, geschraubt.

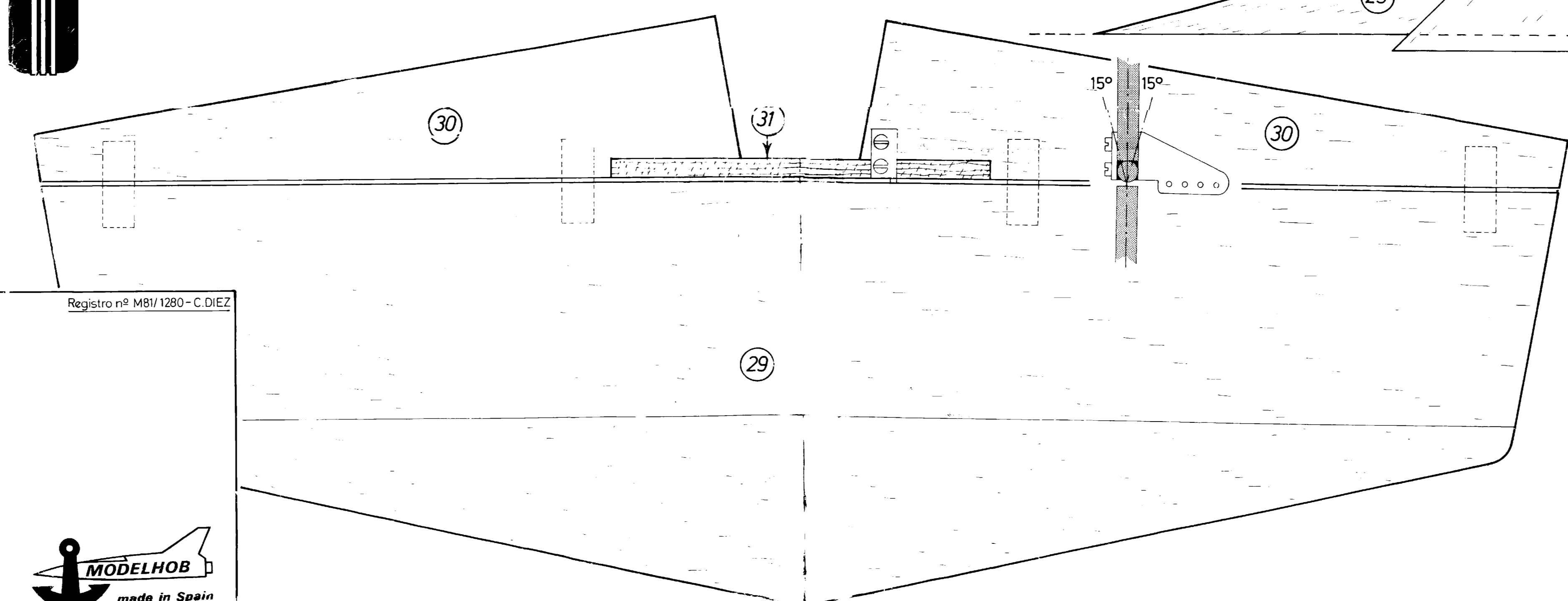
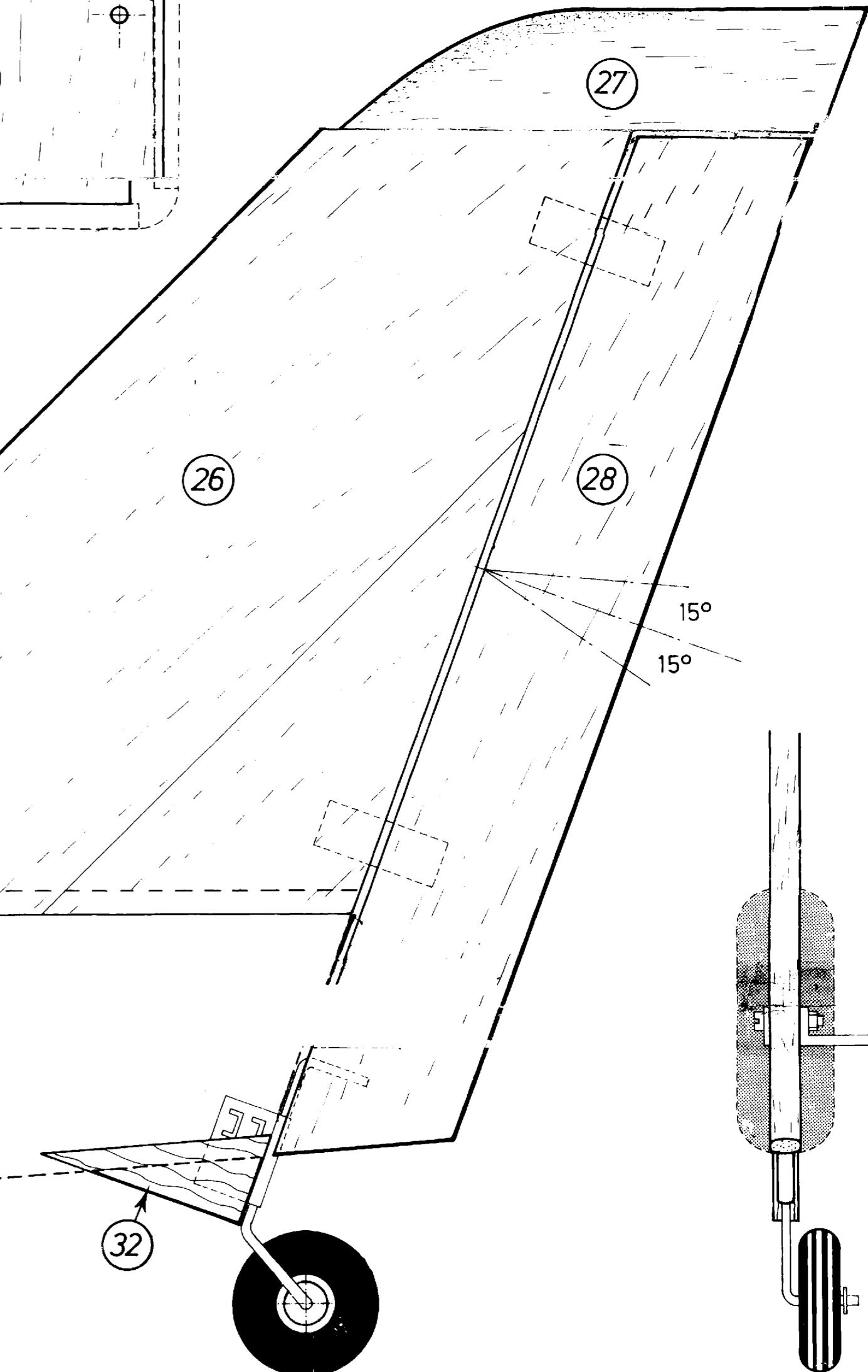
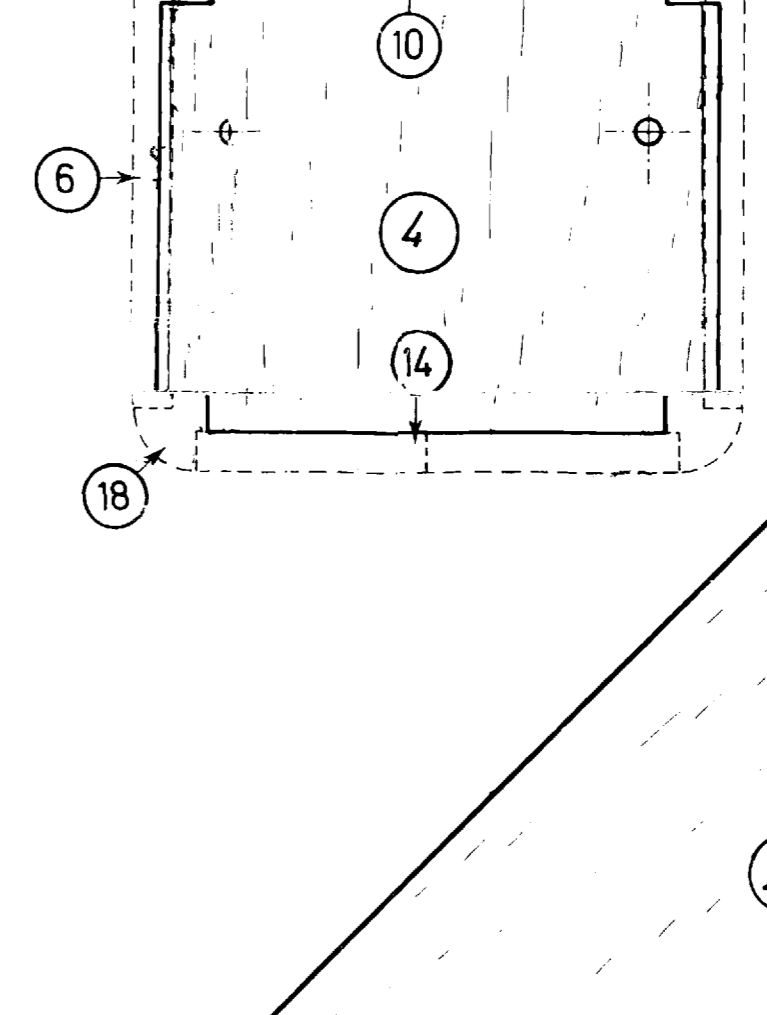
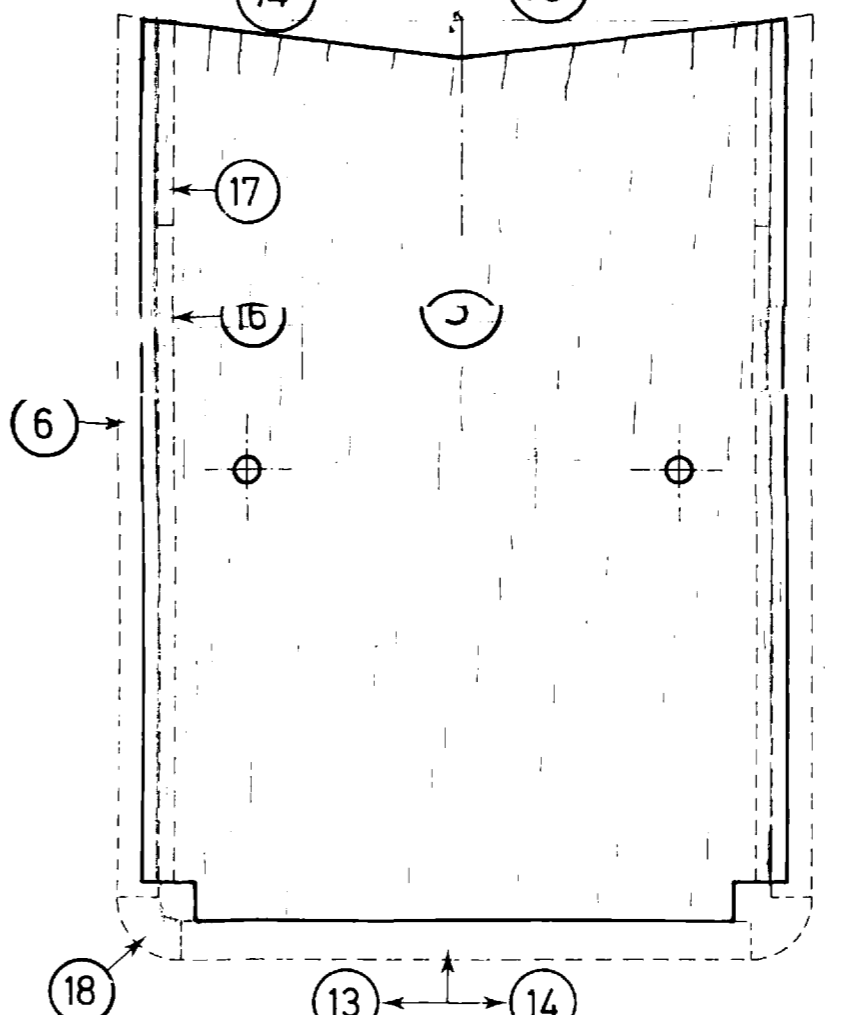
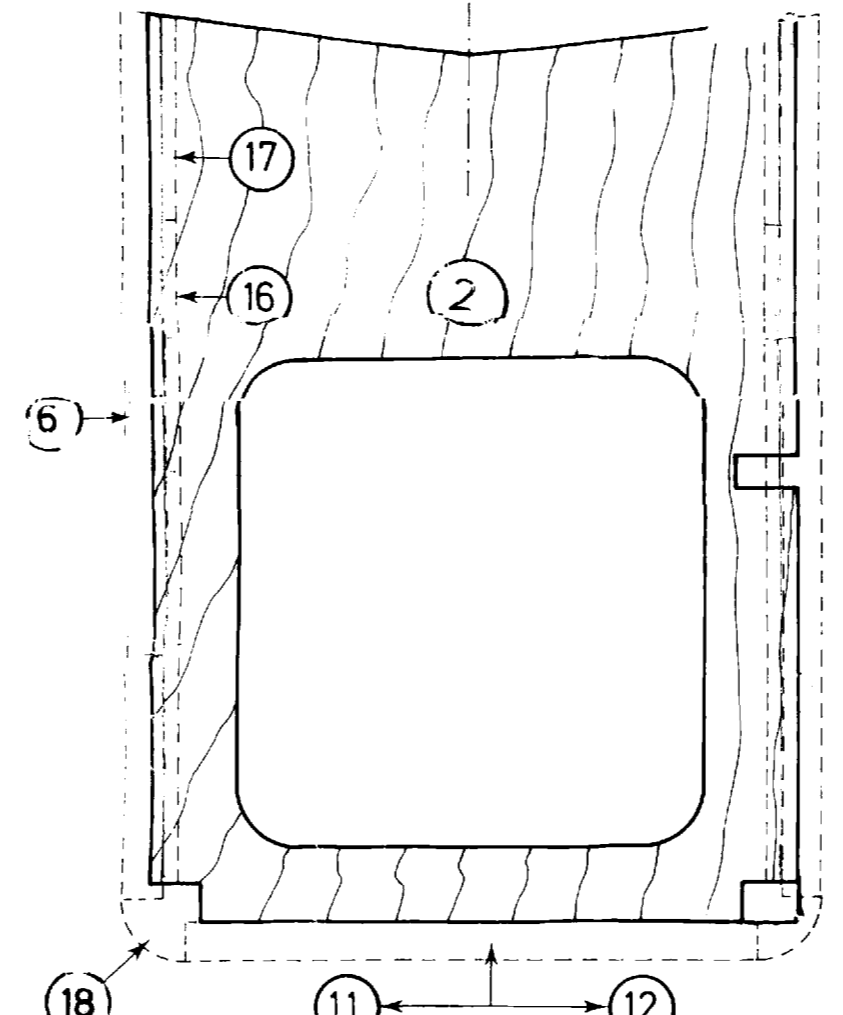
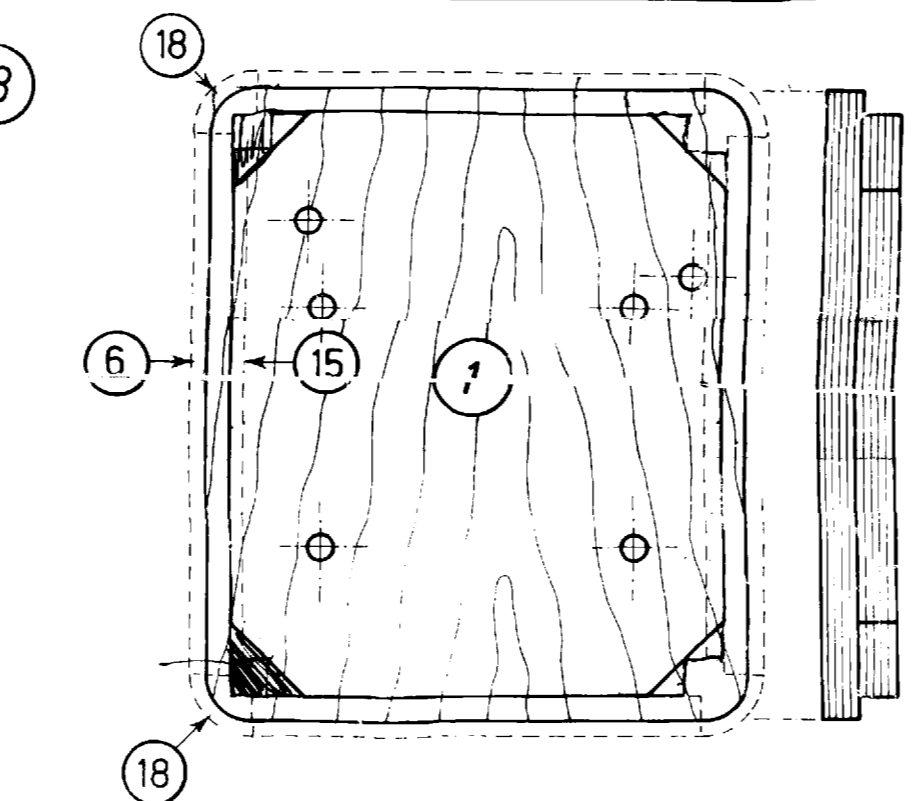
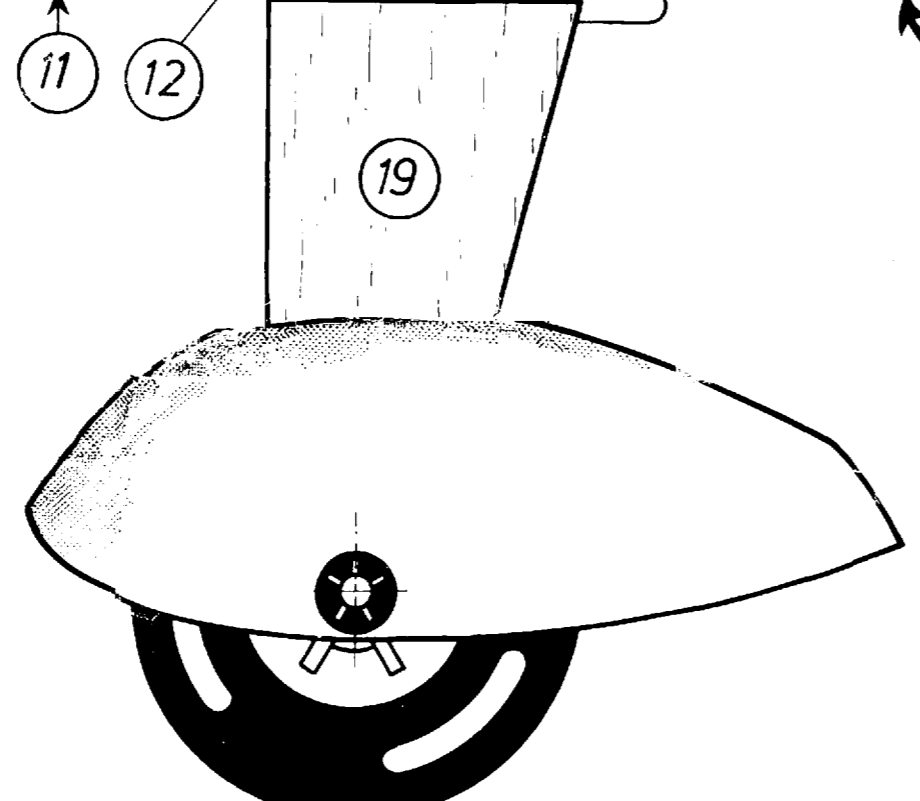

Registro nº M81/1280 - C.DIEZ

Coyote

Envergadura - Wingspan - Envergure	1.450 mm
Longitud - Length - Longueur	1.060 mm
Superficie alar - Wings surface - Surface de l'aile	27.6 dm²
Peso en orden de vuelo - Weight when ready to flying - Poids en ordre de vol	1.850 grms.

