

Comet Stinson Reliant
Wingspan - 25"

CAD Drawing by Paul Bradley Sheet 1 of 11

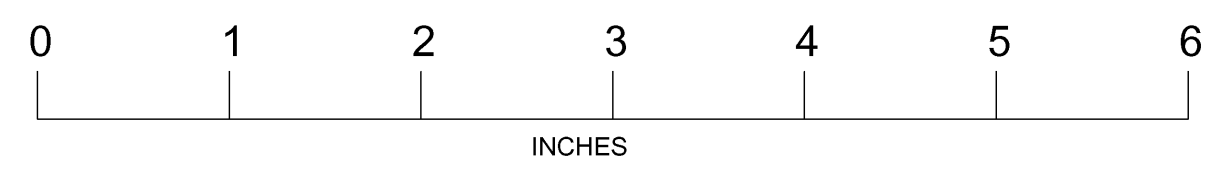

Comet Stinson Reliant
Wingspan - 25"

CAD Drawing by Paul Bradley Sheet 2 of 11

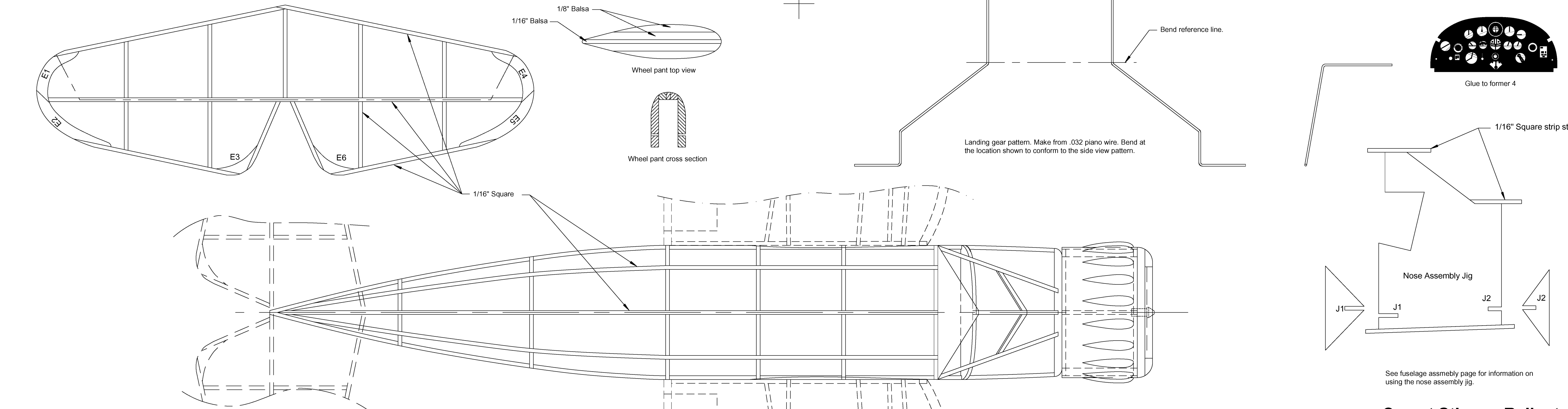
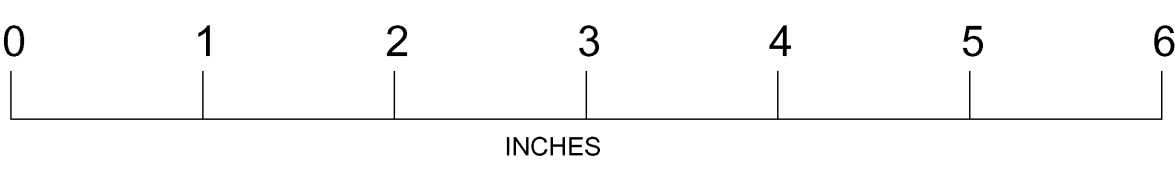

Comet Stinson Reliant
Wingspan - 25"

CAD Drawing by Paul Bradley Sheet 3 of 11

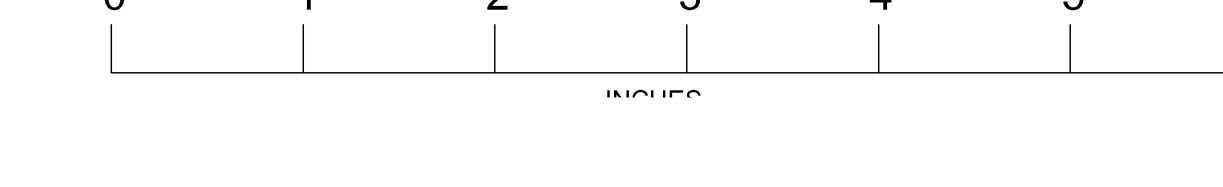

Comet Stinson Reliant
Wingspan - 25"

CAD Drawing by Paul Bradley Sheet 4 of 11

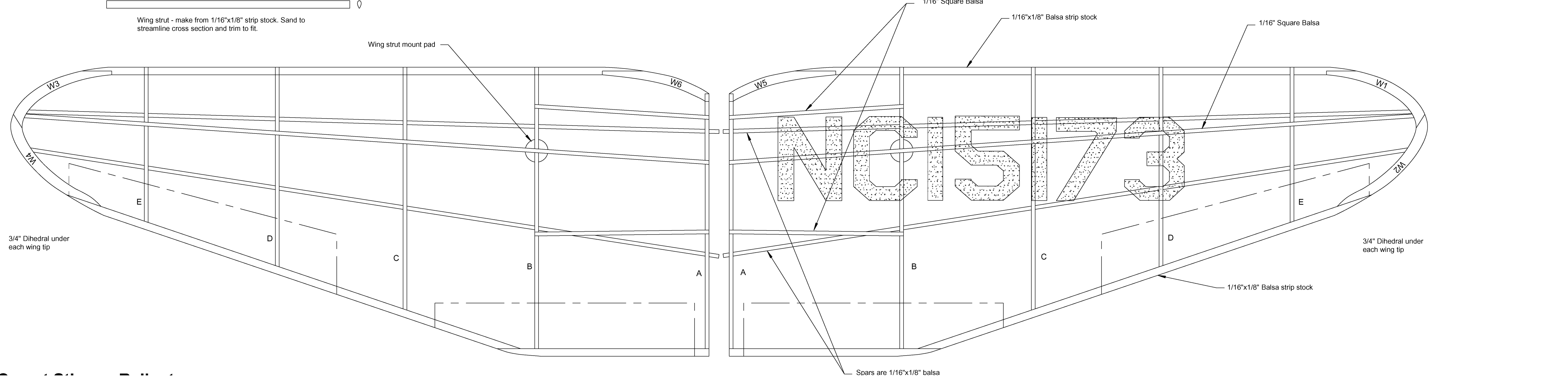
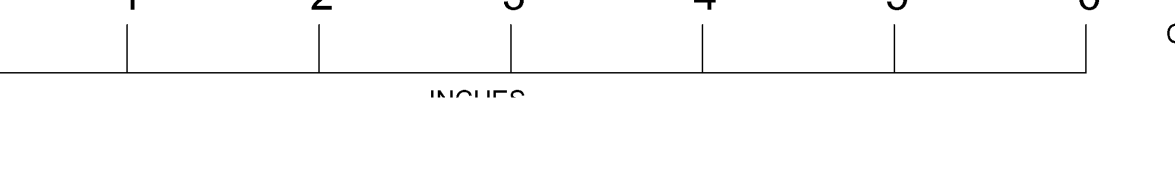

Comet Stinson Reliant
Wingspan - 25"

CAD Drawing by Paul Bradley Sheet 9 of 11

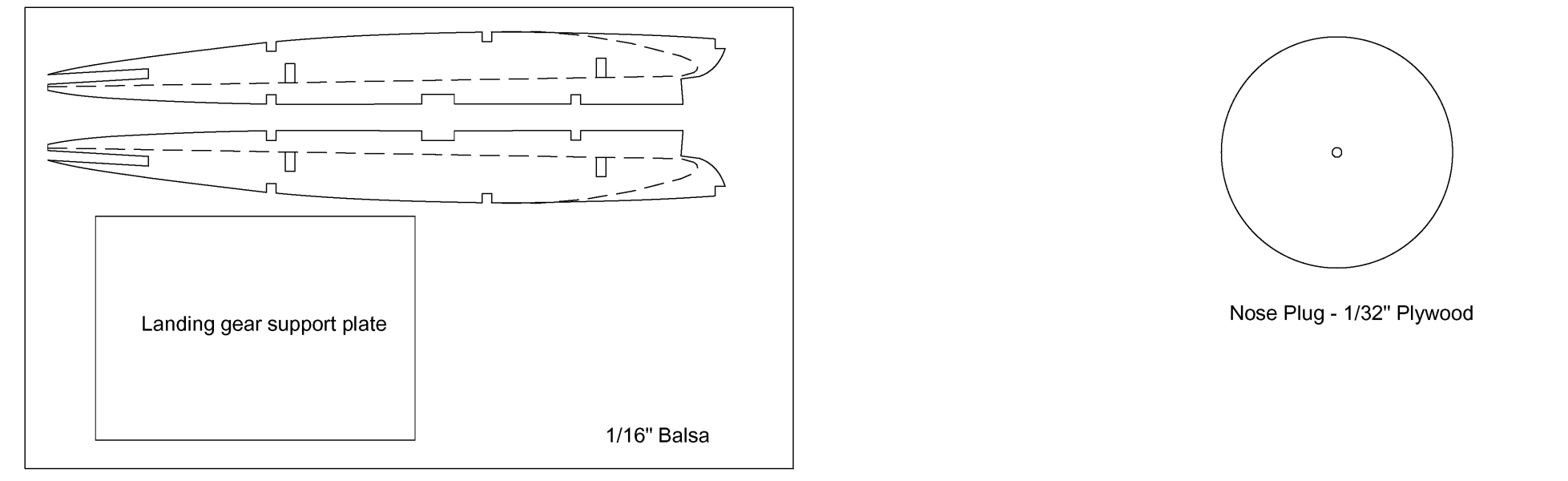
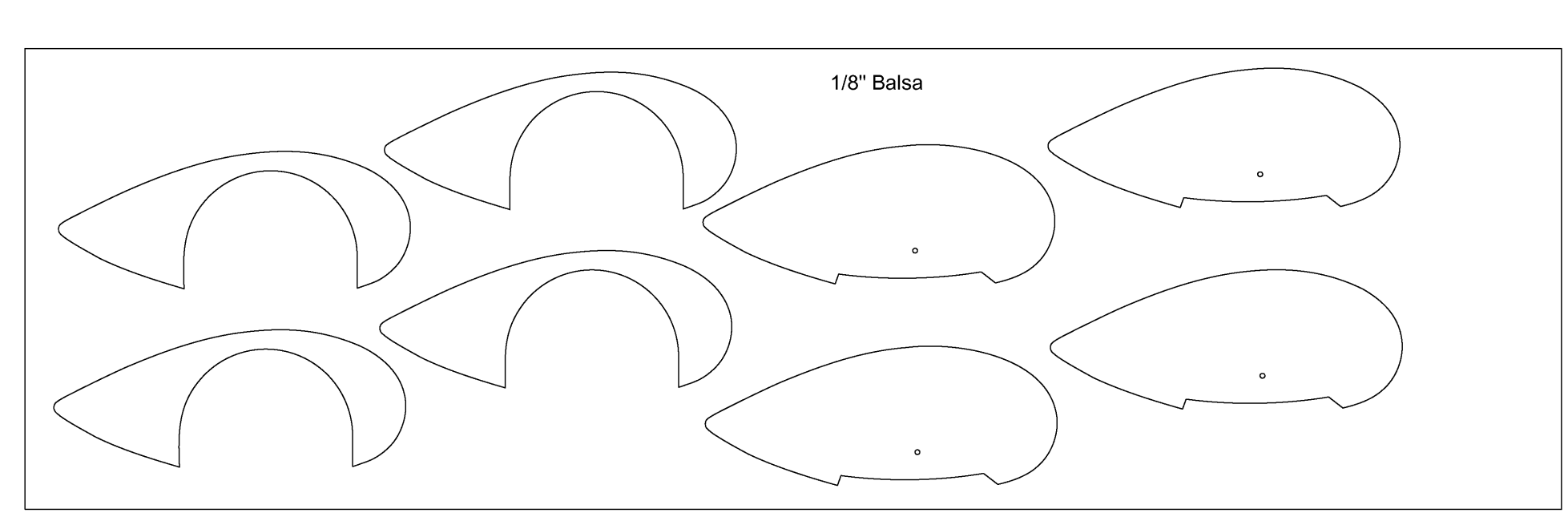
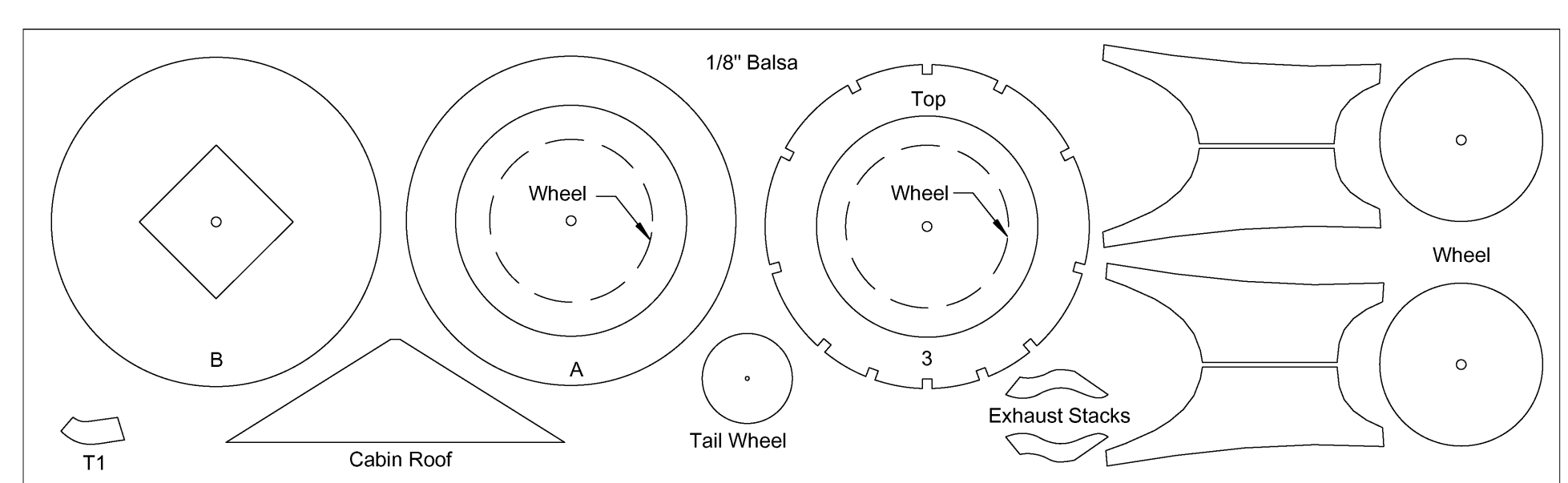
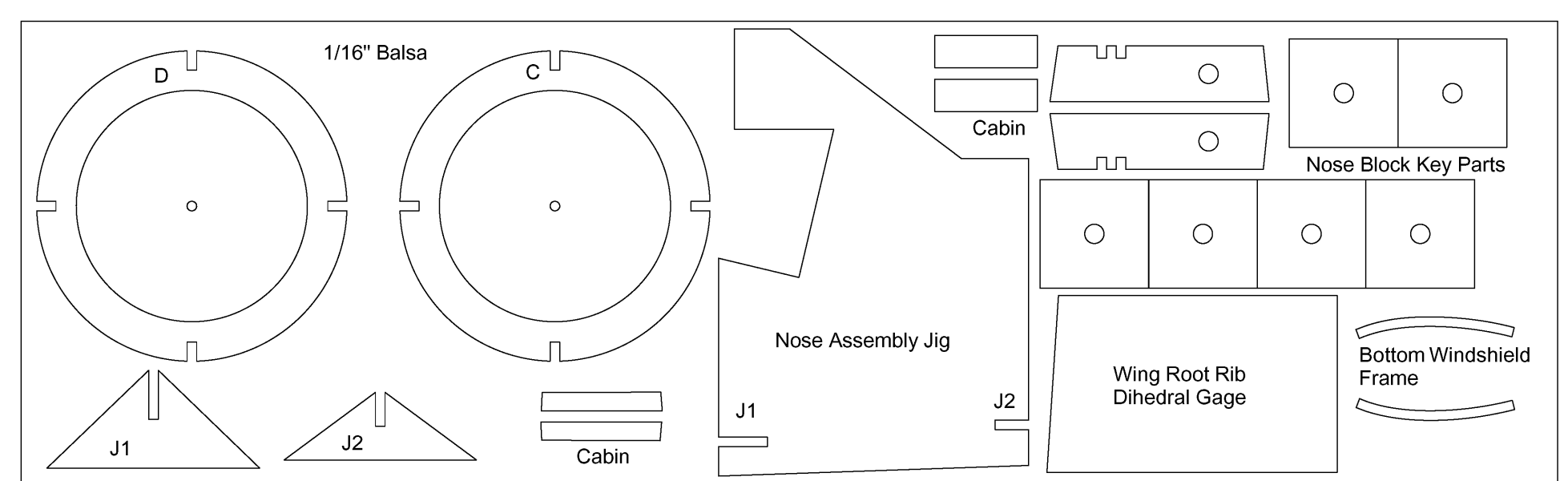
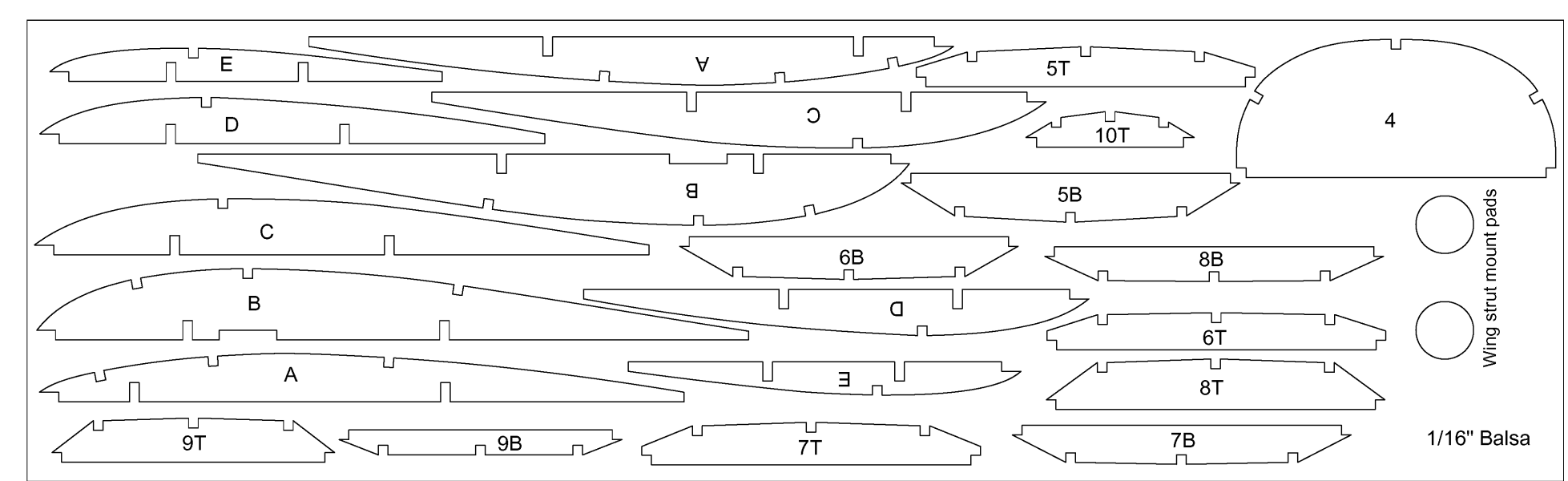
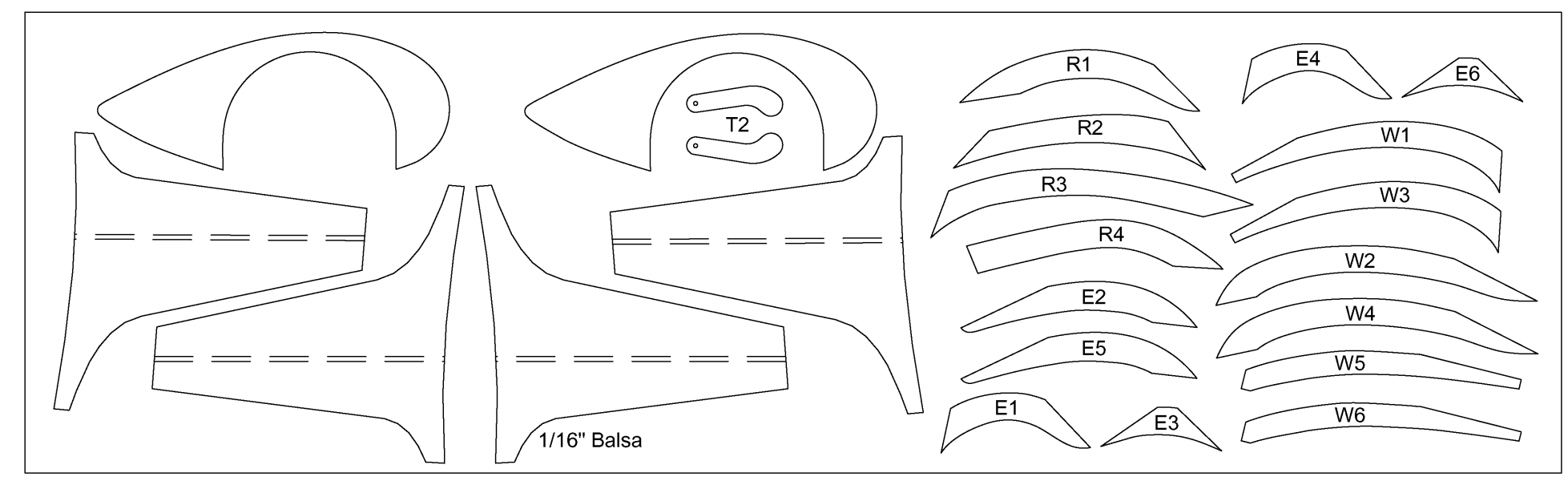

Comet Stinson Reliant
Wingspan - 25"

CAD Drawing by Paul Bradley Sheet 9 of 11

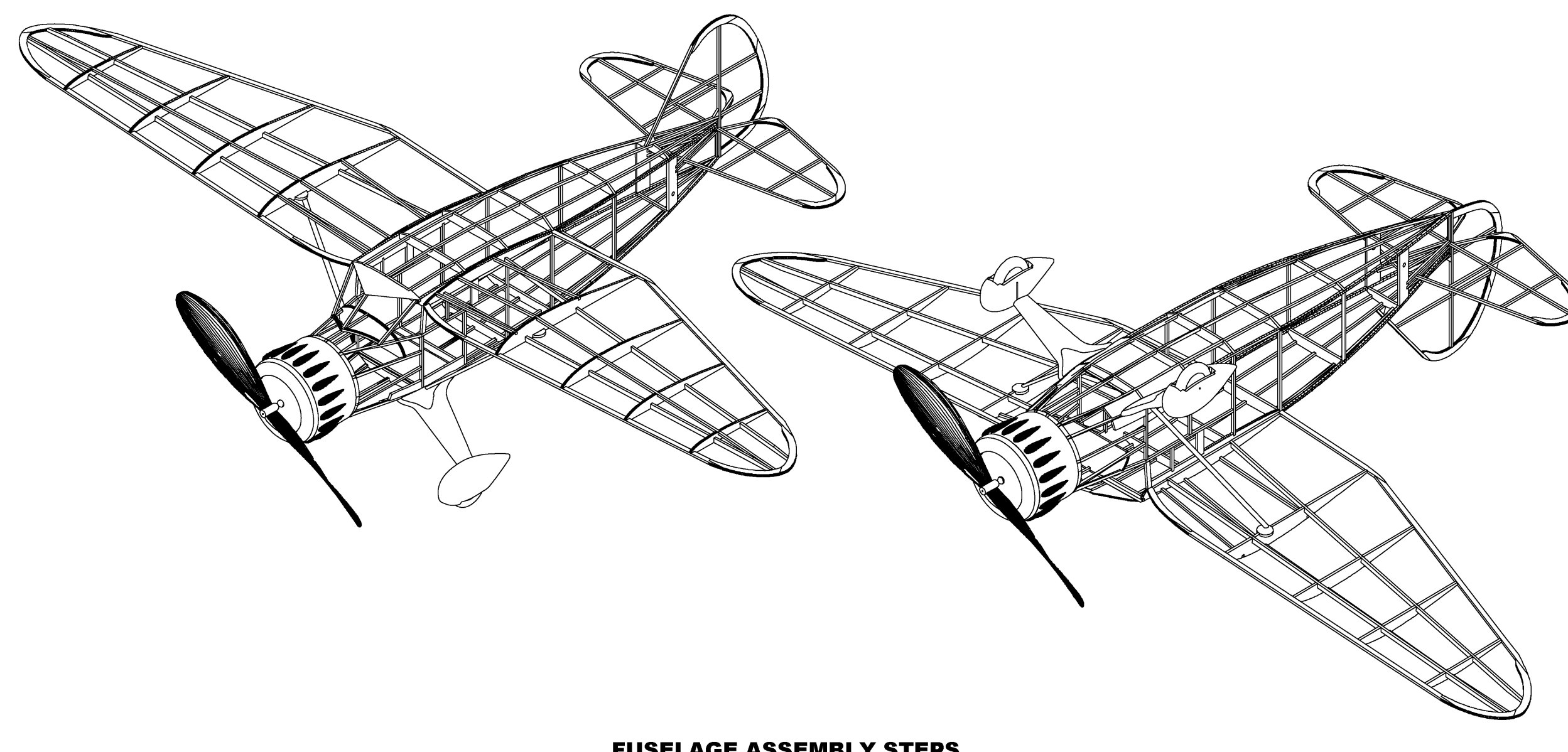
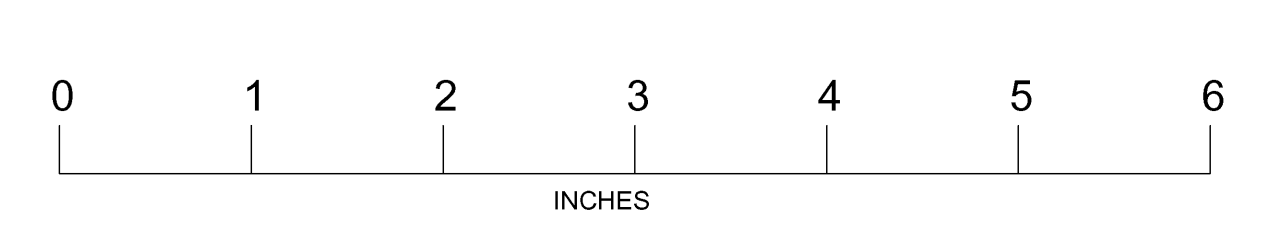

FUSELAGE ASSEMBLY STEPS

- Step 1. Assemble each side over the plan. Do not include the structure forward of the cabin.
- Step 2. Using formers 5 through 8 assemble the sides as shown. Make sure everything is square.
- Step 3. Sand the rear of the fuselage sides on the inside face to a taper so when joined the thickness will be 1/16". Glue the fuselage sides together at the rear and then add formers 9 and 10.
- Step 4. Assemble the jig that is used in the assembly of the fuselage nose. Use 1/16" square strip stock for keys on the jig as shown.
- Step 5. Attach the jig to the fuselage as shown. The keys fit in the center notches of formers 5T and 5B. Use pins to hold the jig in place.
- Step 6. Place former 3 on the jig using the keys in the top and bottom notches as alignment guides. Hold the former to the jig with a pin.
- Step 7. Add the pieces of 1/16" strip stock shown. These pieces will set former 3 in place.
- Step 8. Place former 4 on the jig and in contact with the top two keygrooves that had been installed. The jig sets the former at the proper angle. It will be necessary to adjust the two former notches to get a good fit.
- Step 9. Add the remaining side stringers to the nose.
- Step 10. Remove the jig. Removing the keys from the top of the jig will allow the jig to be extracted from the bottom of the fuselage.
- Step 11. Add the top and bottom stringers. Trim the stringers at the nose flush with former 3. Sand the edge of former 3 to a radius.

Comet Stinson Reliant
Wingspan - 25"

CAD Drawing by Paul Bradley Sheet 10 of 11