

STEP 10. Now glue on F10 (2) at tail and all stringers, (Fig. 7).

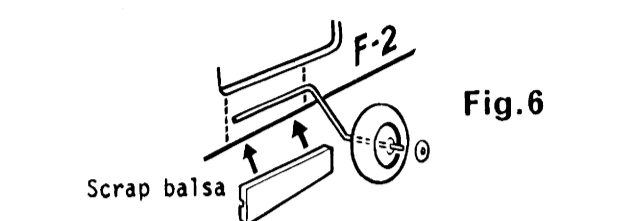

STEP 9. To assemble tail wheel, bend wire as indicated in Fig. 6. Glue in place by sandwiching between F2 and a piece of scrap balsa. Use a sequin and a drop of glue to hold wheel in place.

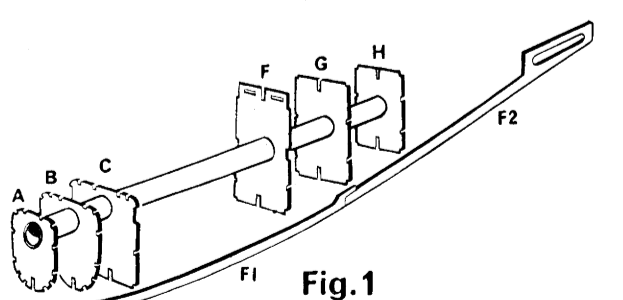
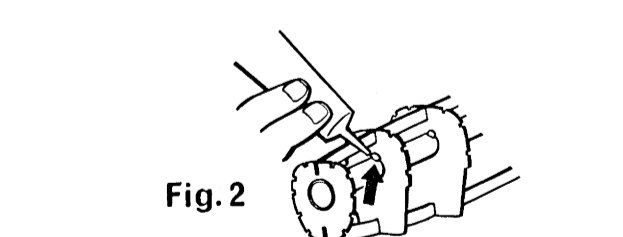
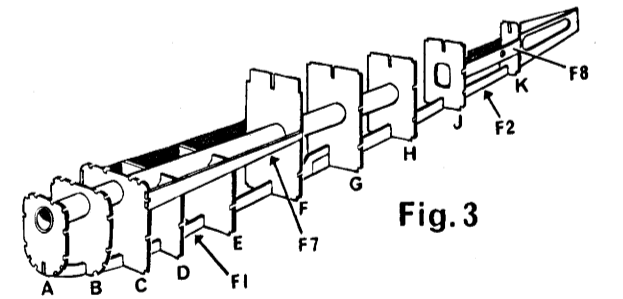
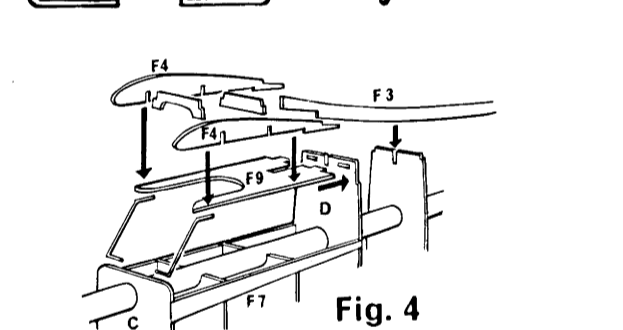
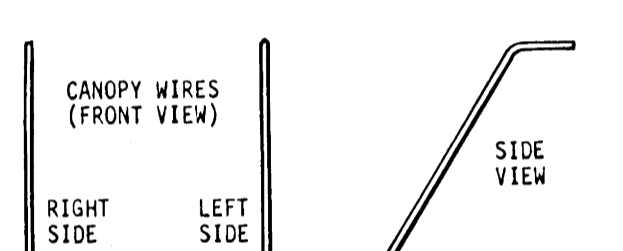
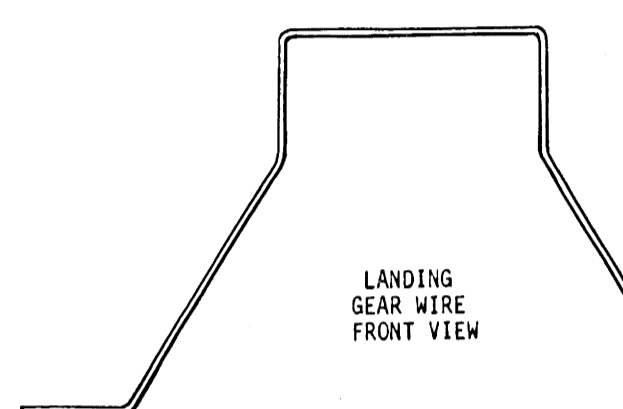

NOTE: Diagram sketches may not be exact for the plan you are building, however, they show correct assembly procedures.

FUSELAGE CONSTRUCTION

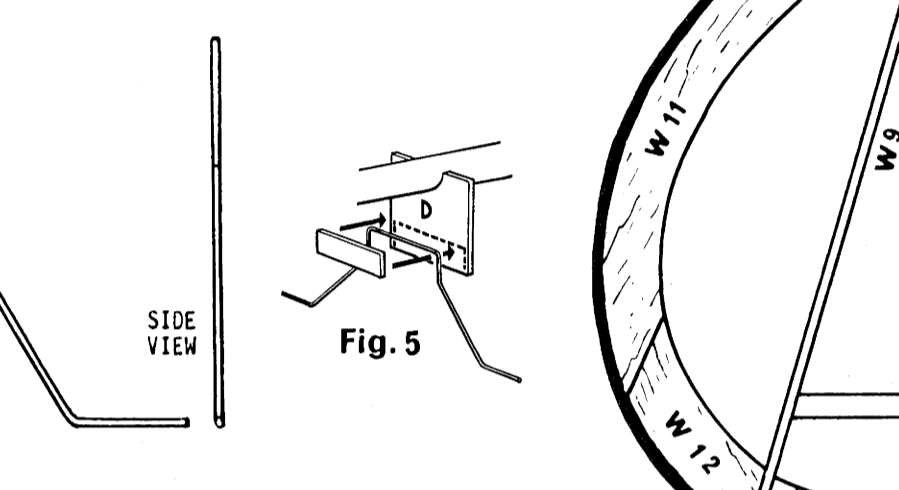
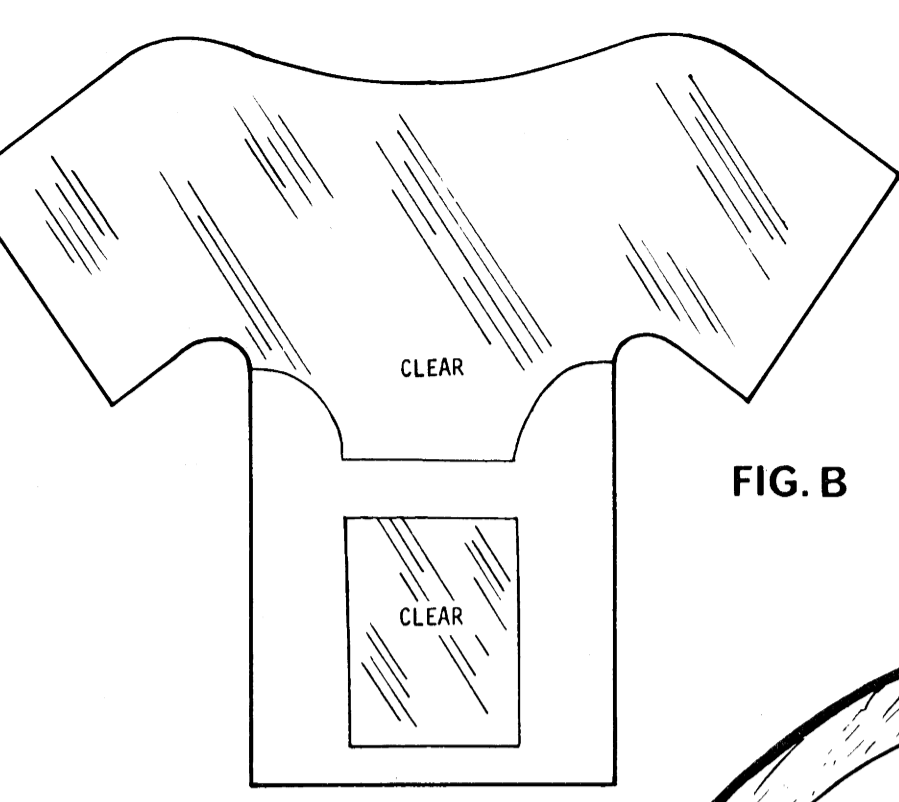

STEP 8. Bend landing gear wire to shape. Position and glue on former D using a piece of scrap balsa to sandwich wire, Fig. 5.

STEP 7. Cut 4 one quarter inch (1/4") pieces of stringer and glue in position as supports for cabin wire, (Fig. A). Bend wire as shown. Position and glue cabin support wire to F9 and former C as in Fig. A.

STEP 6. Position and glue F3 into top slots of F4, H, J & K. Glue F9 into place (Fig. 4). Glue F4 (2), F5 & F6 onto F9.

STEP 5. Glue F7 in place on both sides. Note F7 should be scored or partially cut through at D to accommodate the bend to former C.

STEP 4. Slip formers J & K on to F2. Position and spot glue in place. Be sure J is in proper position by putting F8 in place as a check. Glue F8 in place on both sides, Fig. 3.

STEP 3. Slide formers D & E into place and spot glue, Fig. 3.

STEP 2. While formers are drying, glue F1 to F2 over plan (Fig. A). Note: Use wax paper on top of plan so glue will not stick to paper. When dry glue into bottom slots of A, B, C, F, G, & H (Fig. 1).

STEP 1. Carefully punch out all die-cut formers. Slip formers A, B & C on to front of tube and F, G & H on to rear of tube as shown in Fig. 1. Use side view of plan (Fig. A) for exact positioning of pieces. Spot glue in place as in Fig. 2.

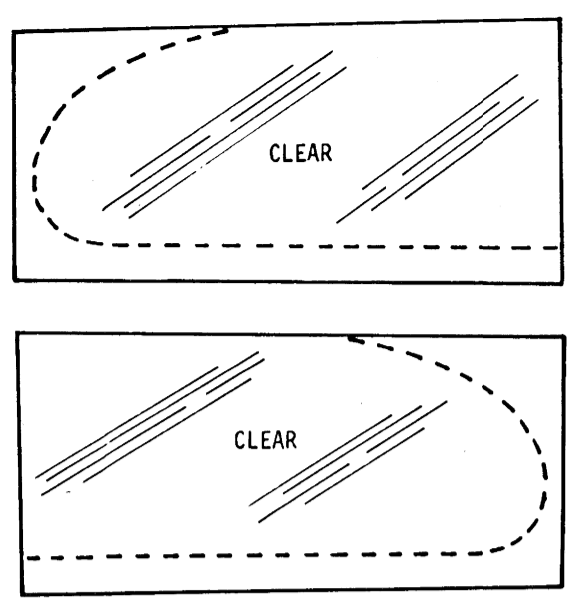

STEP 11. Glue instrument panel to former C. Cut out windshield and side windows from acetate using Fig. B as a guide. Put to one side for the time being and after fuselage is covered with tissue glue in place as indicated in Fig. 15.



STEP 12. To carve nose, mark pattern as indicated in Fig. C on 1/2" thick balsa block. Cut out nose block using heavy black line as the cut line. Dotted line is indicating size and shape of front of nose. Note side view of Fig. C, you will see the nose tapers. Carve and sand nose block neatly, check for proper fit to former A. Mark position for nose button, drill and fit but DO NOT GLUE IT! Glue nose block to former A.

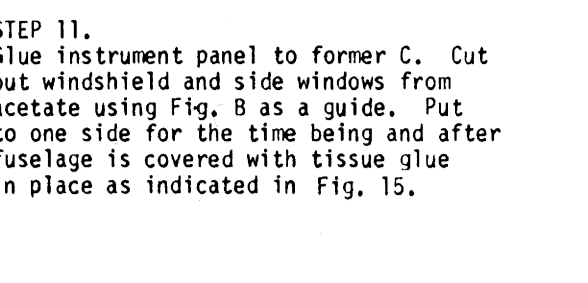
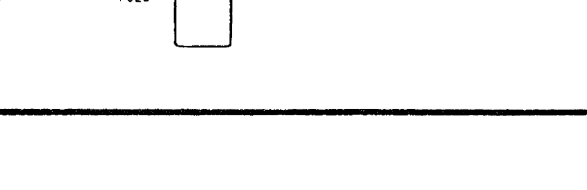
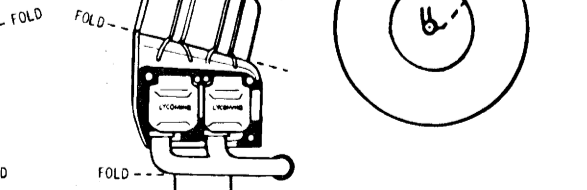
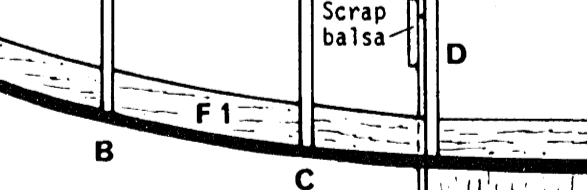
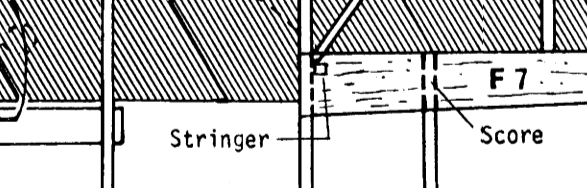
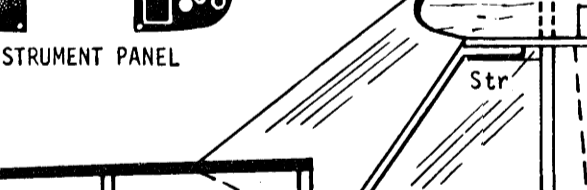
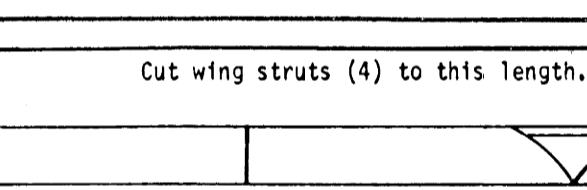
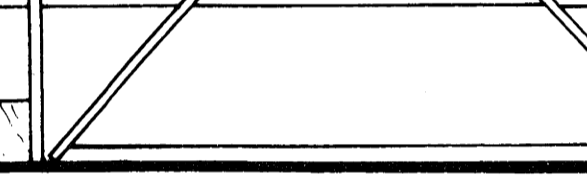

STEP 13. Cut trailing edge W 10 from 3/8" stringer and pin to plan (FIG. D). Lay wax paper over plan first so pieces can be easily lifted off.

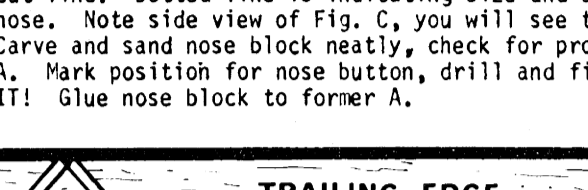

STEP 14. Cut main spar to length and pin to plan (FIG. D) as indicated. Glue W 8 to it and trailing edge as in Fig. 9.

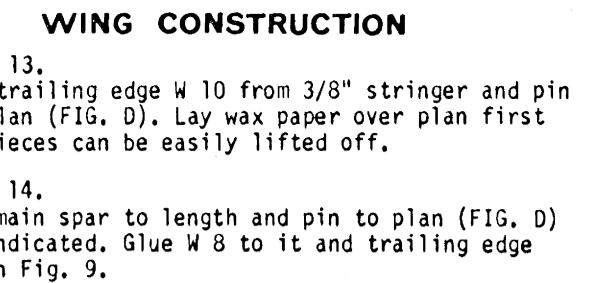
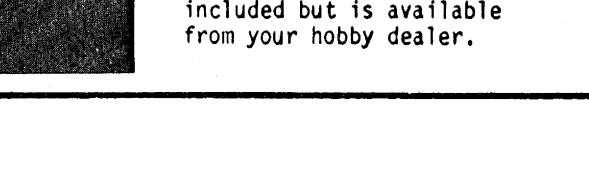
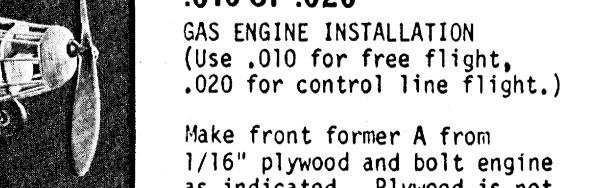
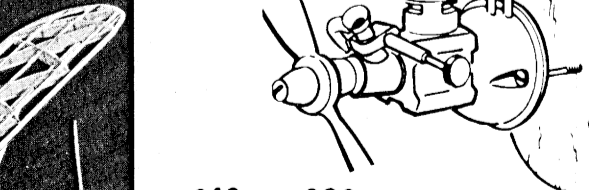
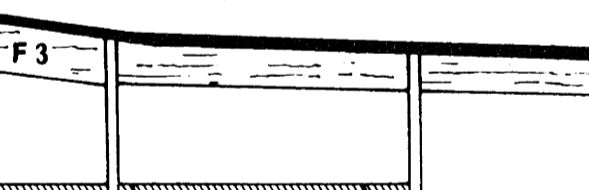
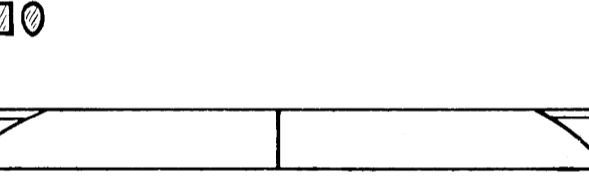
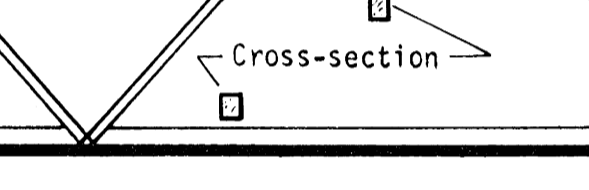
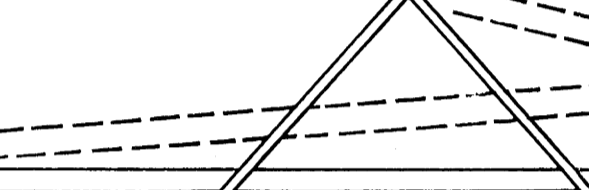
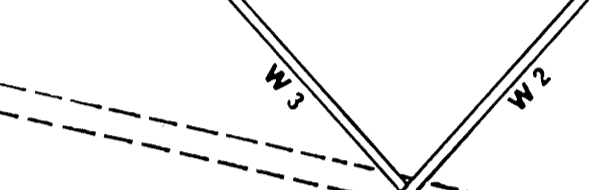
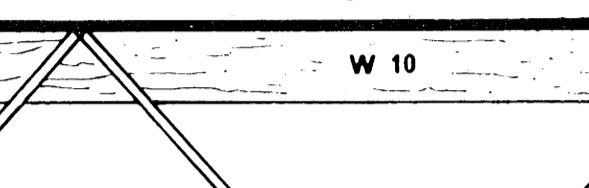
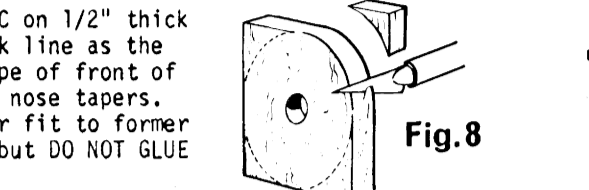
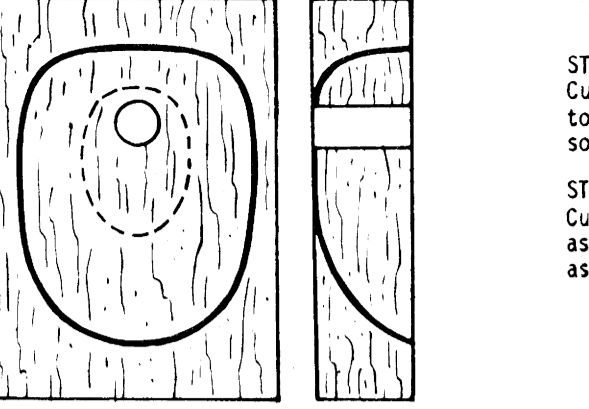
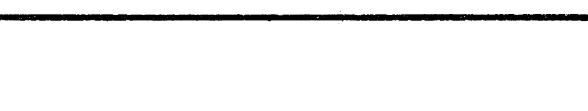
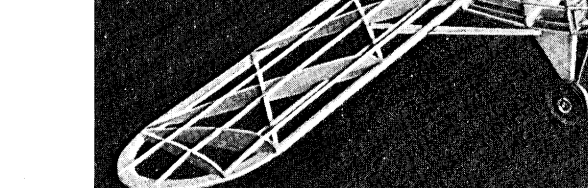
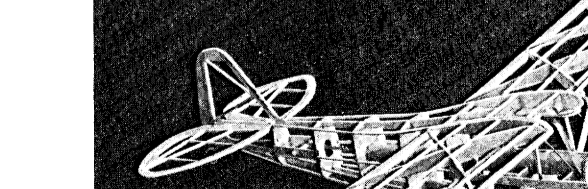
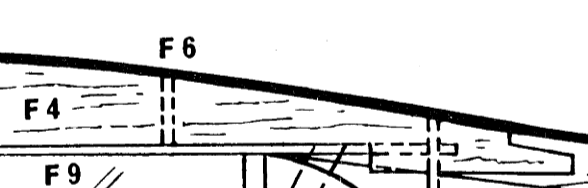
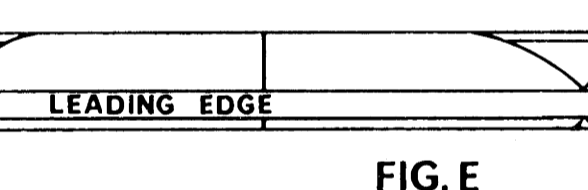
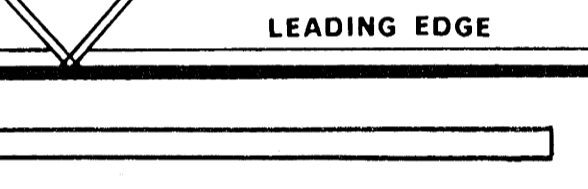
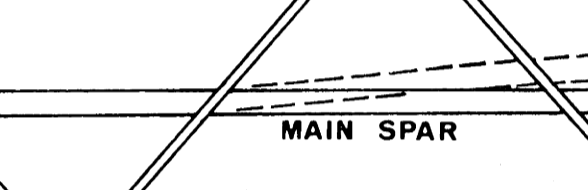
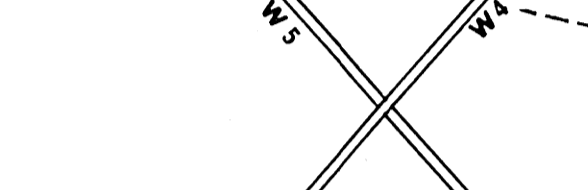

STEP 13. Cut trailing edge W 10 from 3/8" stringer and pin to plan (FIG. D). Lay wax paper over plan first so pieces can be easily lifted off.

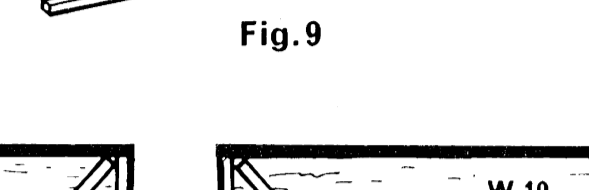

STEP 14. Cut main spar to length and pin to plan (FIG. D) as indicated. Glue W 8 to it and trailing edge as in Fig. 9.

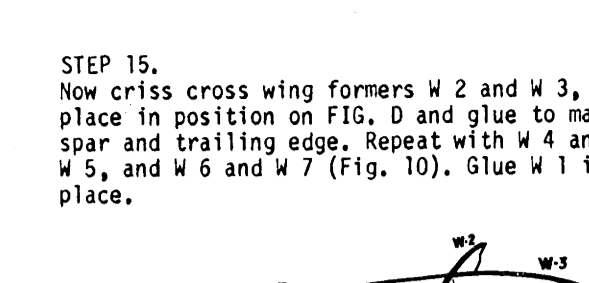
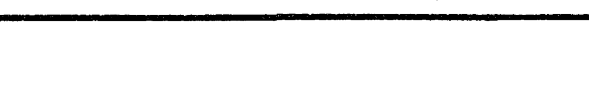
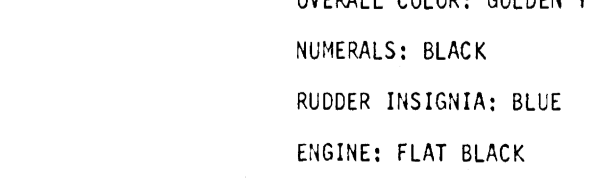
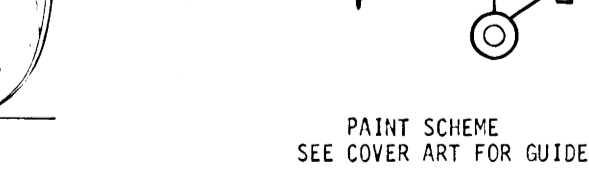
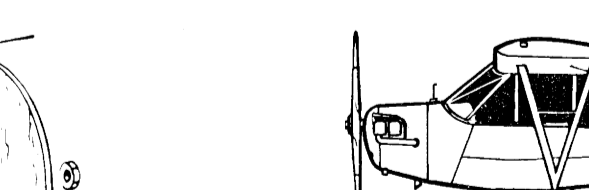
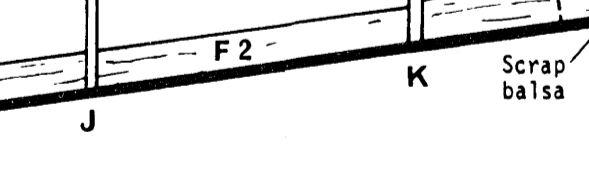
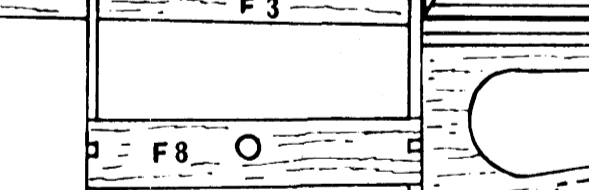
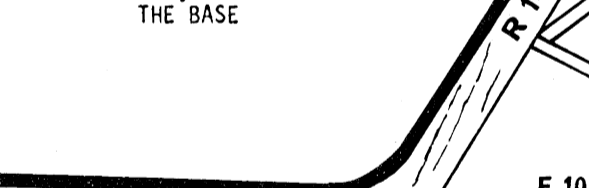
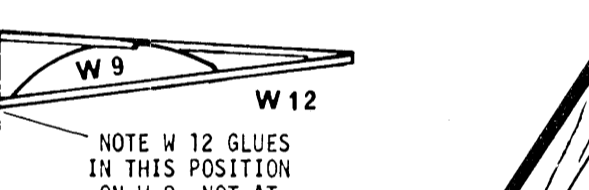
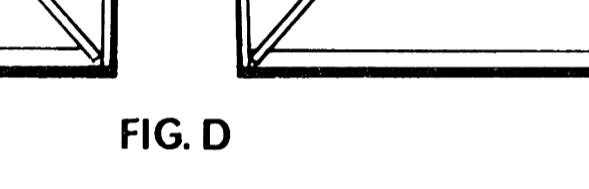
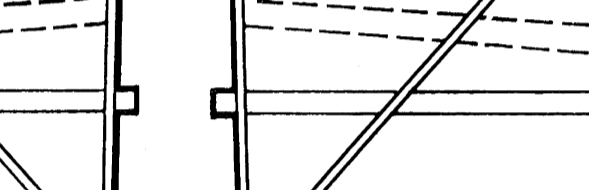
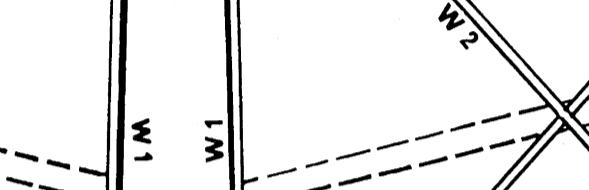

STEP 15. Now criss cross wing formers W 2 and W 3, place in position on FIG. D and glue to main spar and trailing edge. Repeat with W 4 and W 5, and W 6 and W 7 (Fig. 10). Glue W 1 in place.

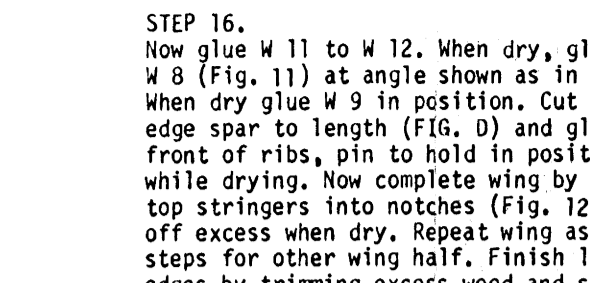
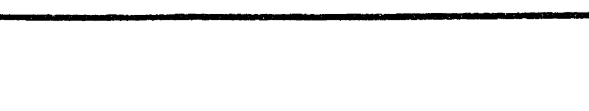
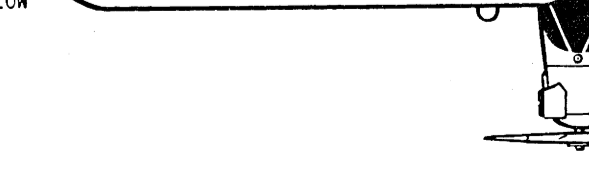
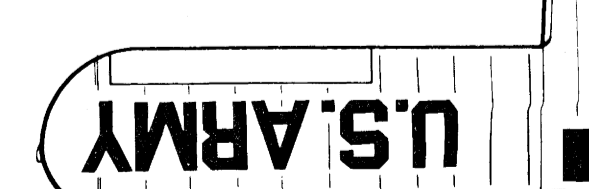
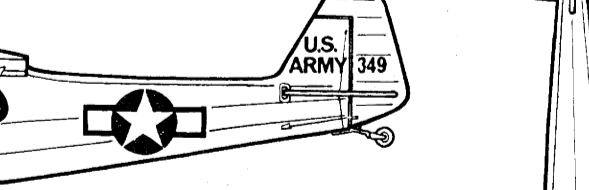
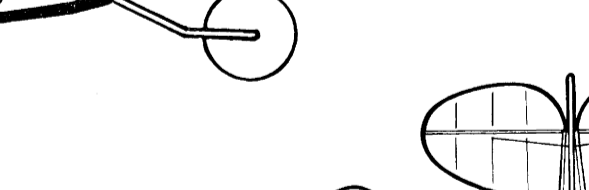
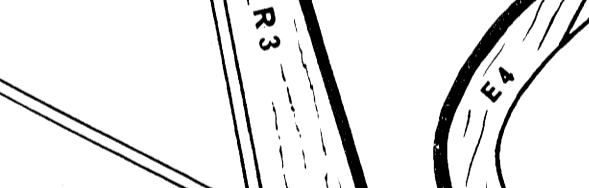
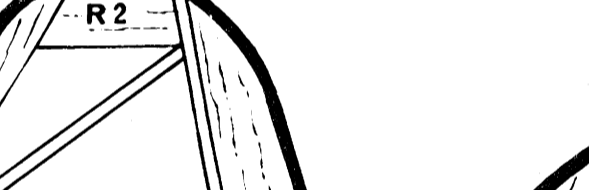
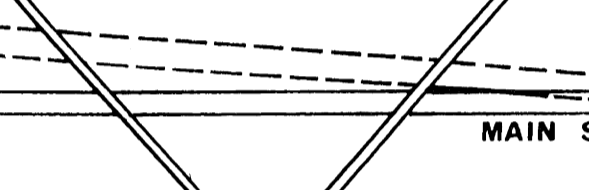
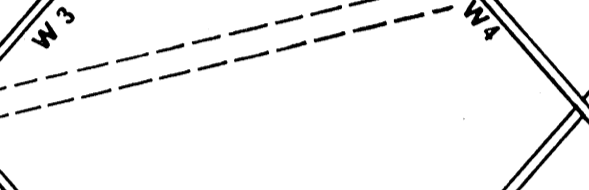
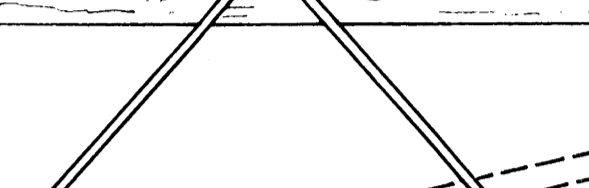

STEP 16. Now glue W 11 to W 12. When dry, glue to W 8 (Fig. 11) at angle shown as in FIG. E. When dry glue W 9 in position. Cut leading edge spar to length (FIG. D) and glue to front of ribs, pin to hold in position while drying. Now complete wing by gluing top stringers into notches (Fig. 12), trim off excess when dry. Repeat wing assembly steps for other wing half. Finish leading edges by trimming excess wood and sanding to rounded edge (Fig. 13). Trailing edges can also be sanded and rounded at this time.

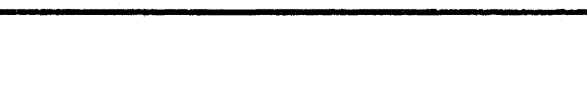
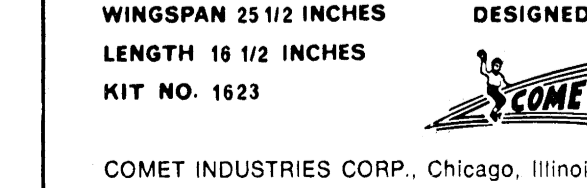
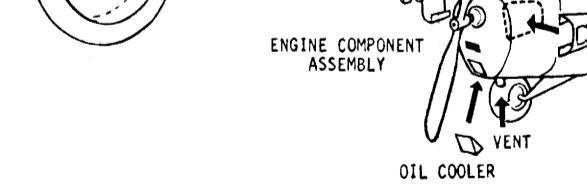
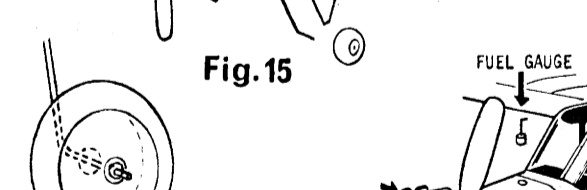
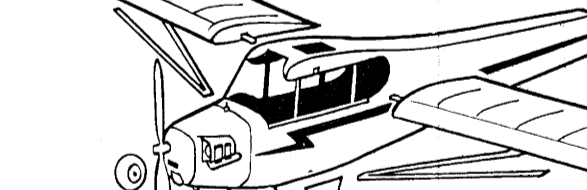
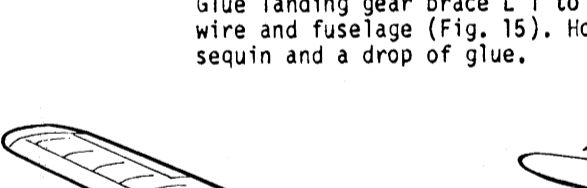
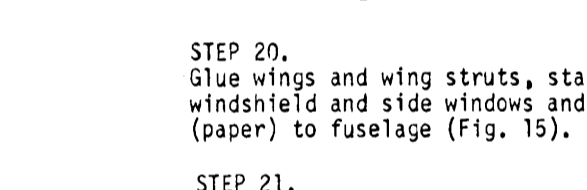
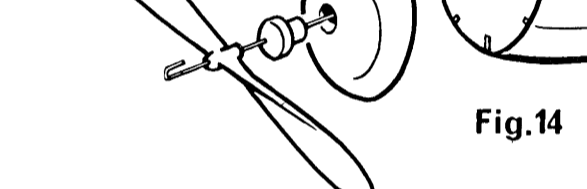
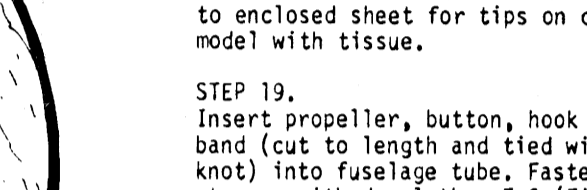
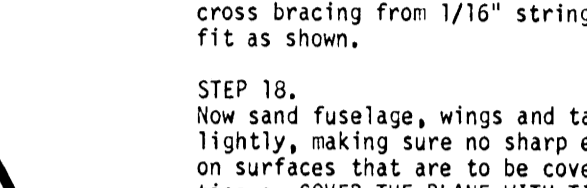
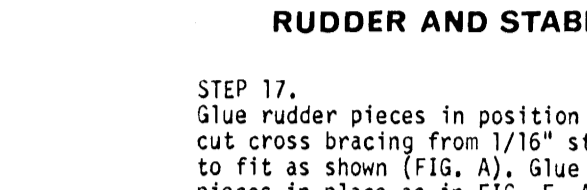
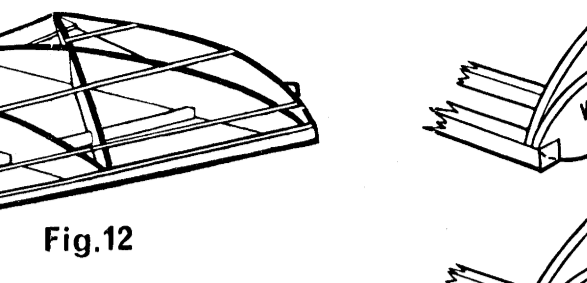
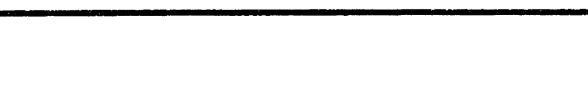
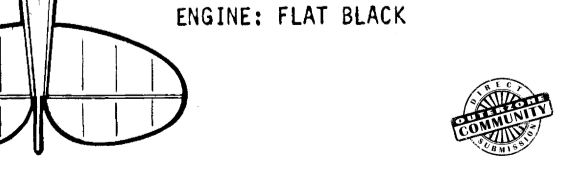
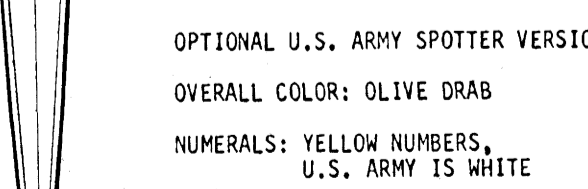
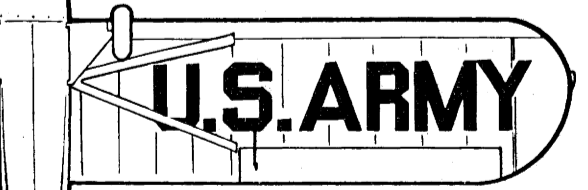
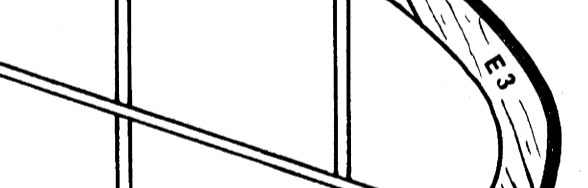
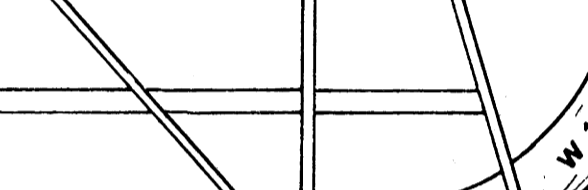
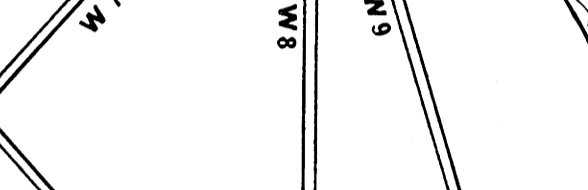
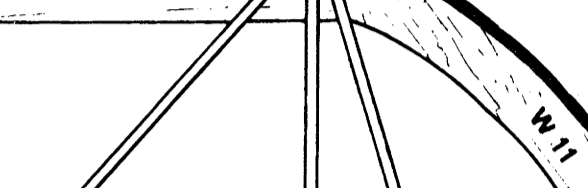
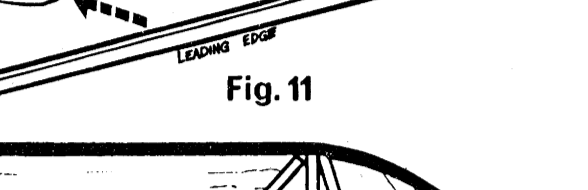
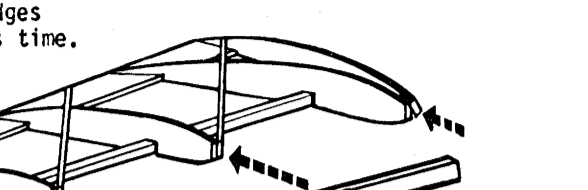
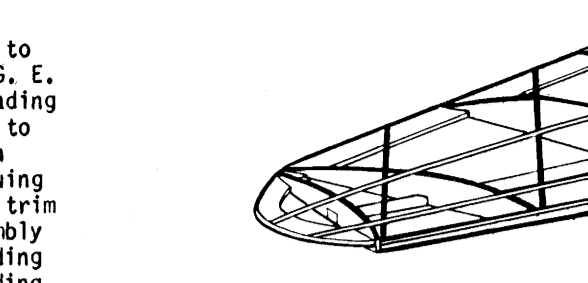
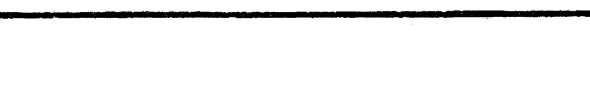
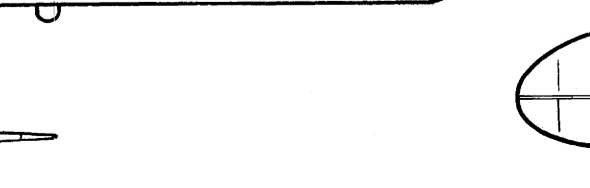
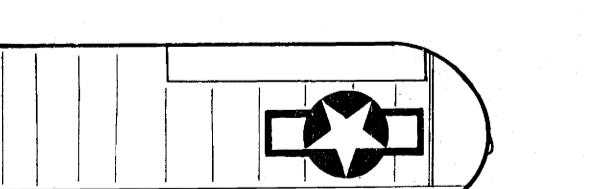
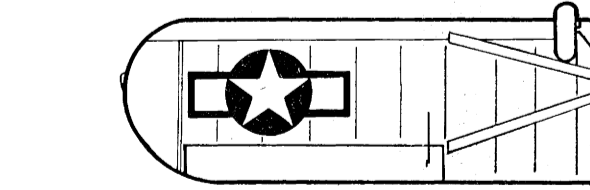
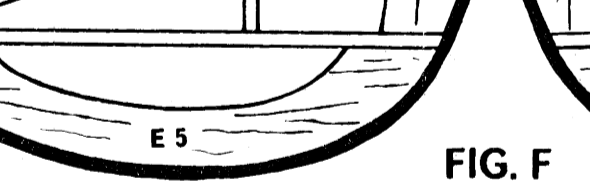
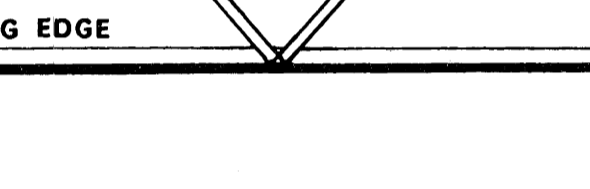
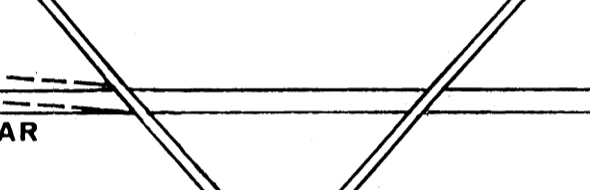
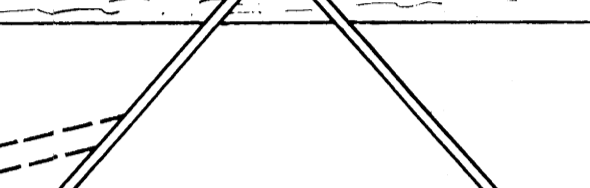

START HERE WITH COMET'S SUPERX SPEED CONSTRUCTION

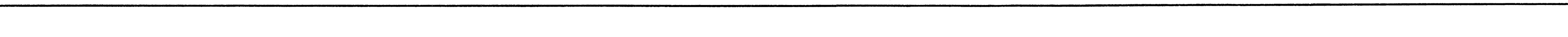
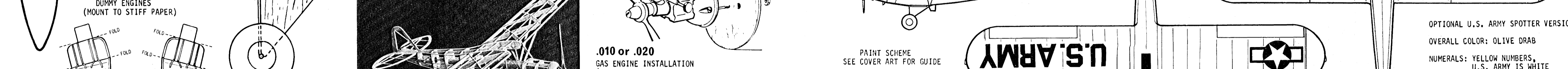
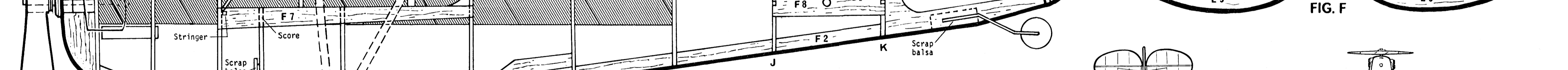
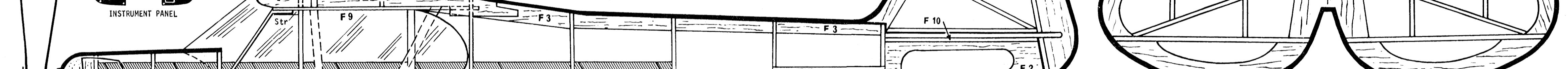
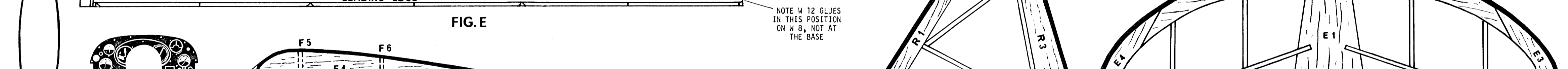
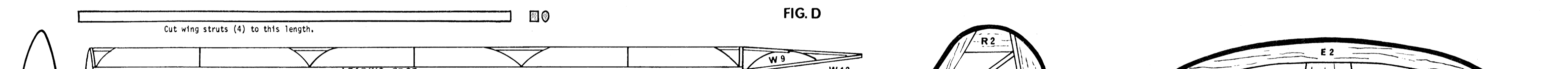
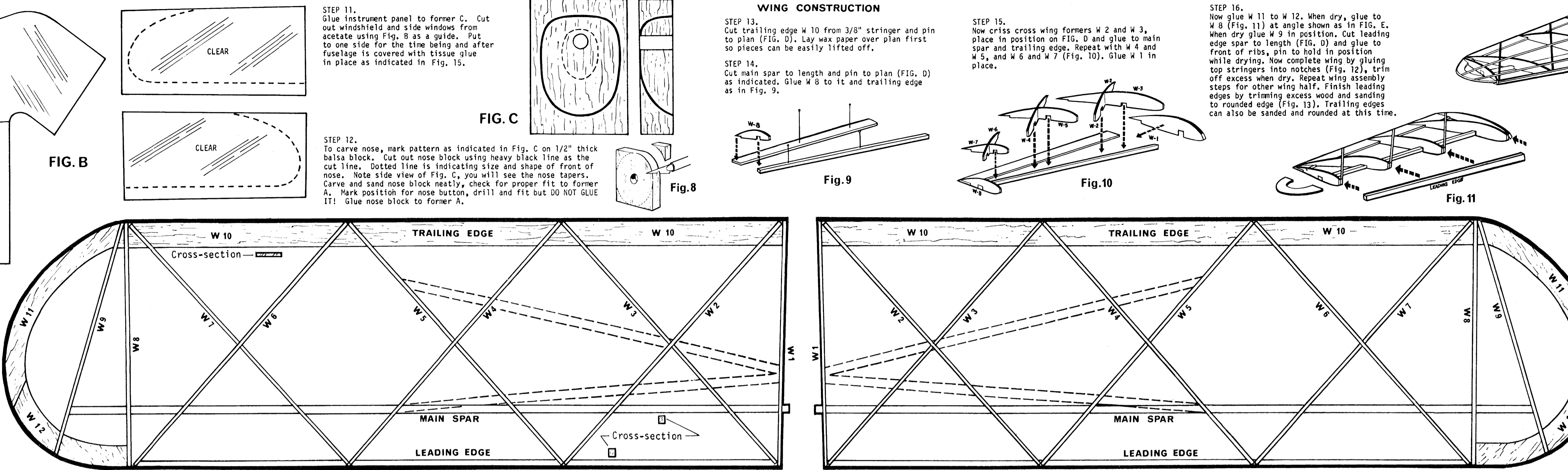

RUDDER AND STABILIZER

STEP 17. Glue rudder pieces in position over plan, cut cross bracing from 1/16" stringer wood to fit as shown (FIG. A). Glue stabilizer pieces in place as in FIG. F. Again cut cross bracing from 1/16" stringer wood to fit as shown.

STEP 18. Now sand fuselage, wings and tail pieces lightly, making sure no sharp edges protrude on surfaces that are to be covered with tissue. COVER THE PLANE WITH TISSUE. Refer to enclosed sheet for tips on covering your model with tissue.

STEP 19. Insert propeller, button, hook and rubber band (cut to length and tied with square knot) into fuselage tube. Fasten rubber band at rear with dowel thru F 6 (Fig. 14).

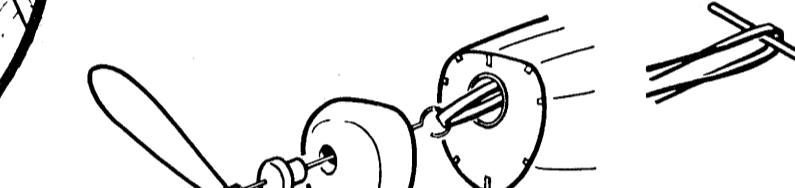

STEP 20. Glue wings and wing struts, stabilizer, rudder, windshield and side windows and dummy engines (paper) to fuselage (Fig. 15).

STEP 21. Glue landing gear brace L 1 to landing gear wire and fuselage (Fig. 15). Hold wheel with sequin and a drop of glue.

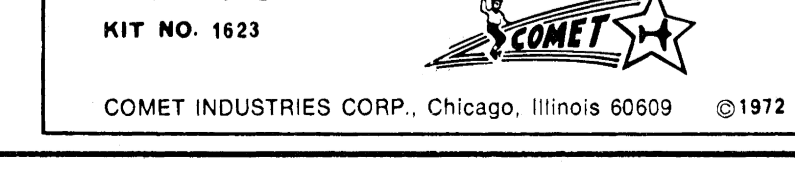
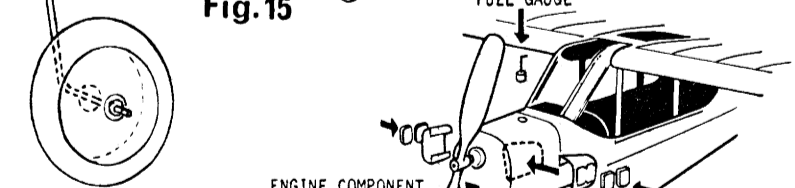
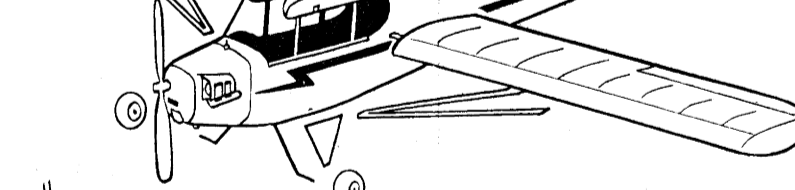
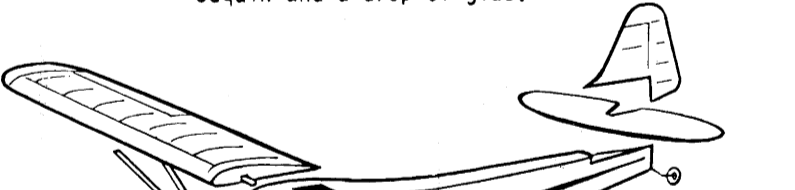

.010 or .020 GAS ENGINE INSTALLATION (Use .010 for free flight, .020 for control line flight.) Make front former A from 1/16" plywood and bolt engine as indicated. Plywood is not included but is available from your hobby dealer.

PAINT SCHEME SEE COVER ART FOR GUIDE OVERALL COLOR: GOLDEN YELLOW NUMERALS: BLACK RUDDER INSIGNIA: BLUE ENGINE: FLAT BLACK

OPTIONAL U.S. ARMY SPOTTER VERSION OVERALL COLOR: OLIVE DRAB NUMERALS: YELLOW NUMBERS, U.S. ARMY IS WHITE ENGINE: FLAT BLACK

Piper Cub J3

FEATURING SUPERX SPEED CONSTRUCTION WINGSPAN 25 1/2 INCHES LENGTH 18 1/2 INCHES DESIGNED BY COMET KIT NO. 1623

COMET INDUSTRIES CORP., Chicago, Illinois 60609 © 1972