

CAUTION: LEFT & RIGHT REFERENCES ARE REVERSED WHEN MARKING UPSIDE DOWN OVER TOP VIEW.

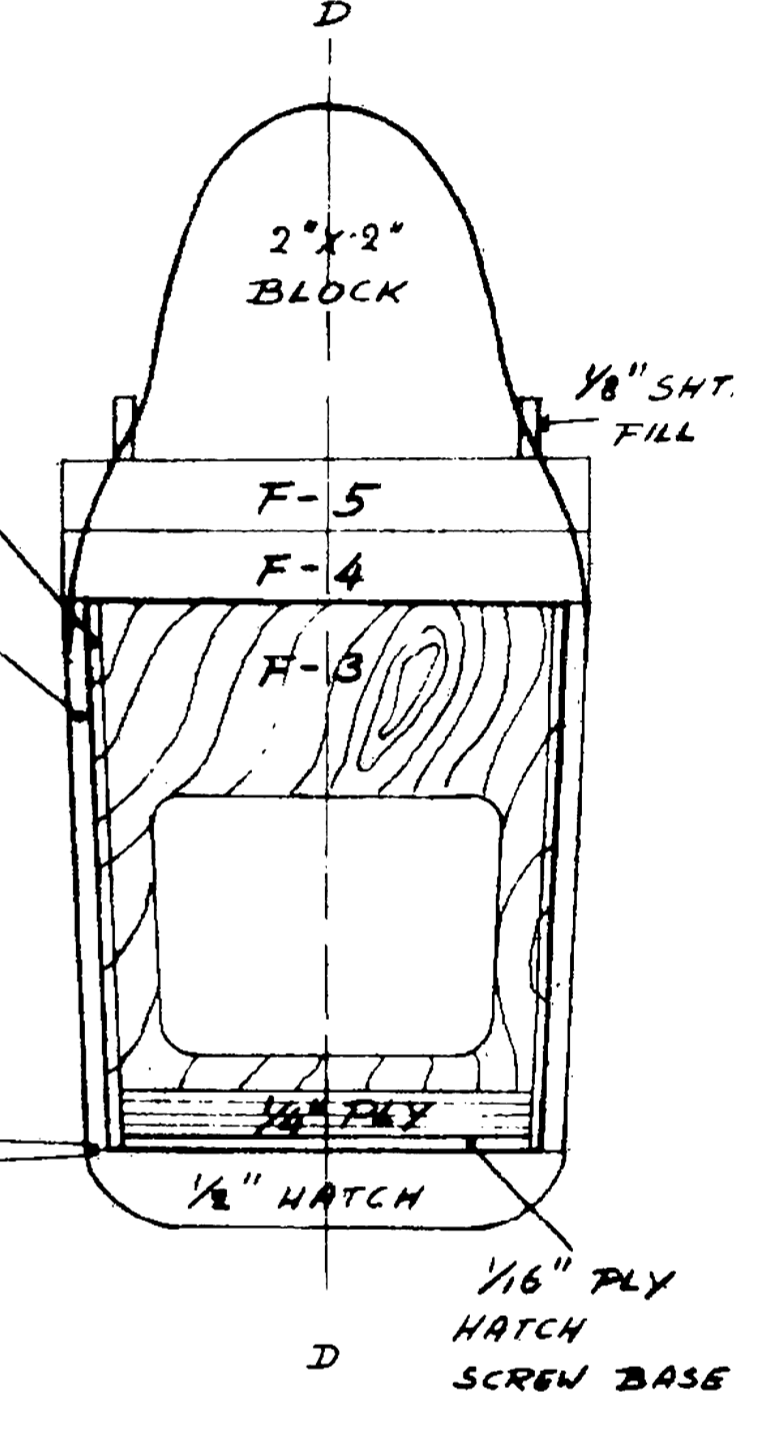
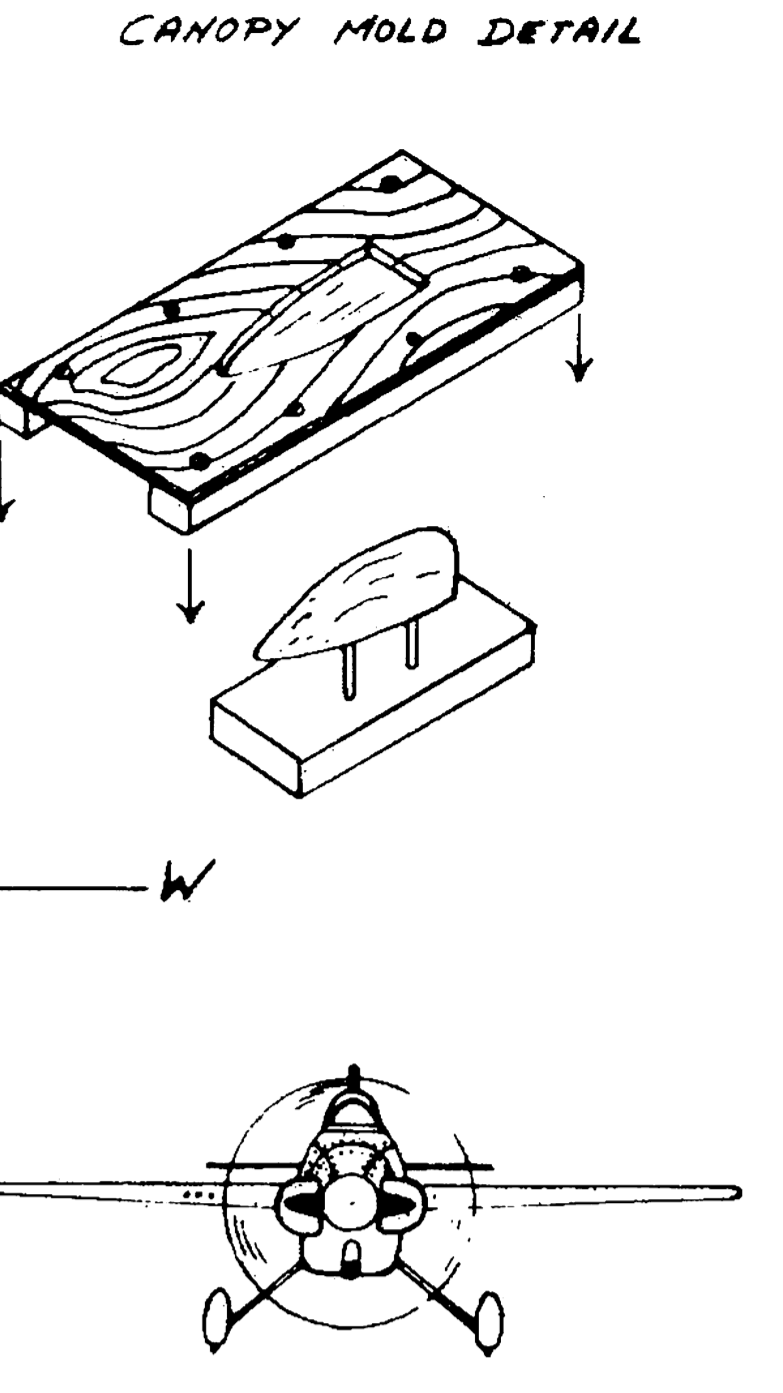
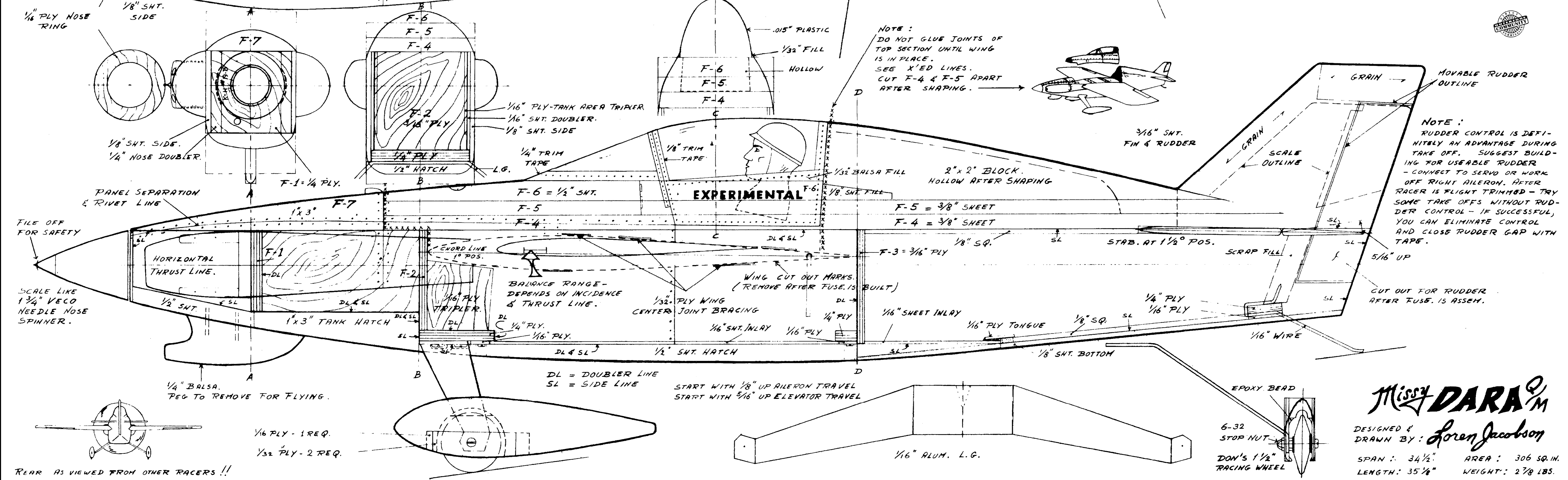
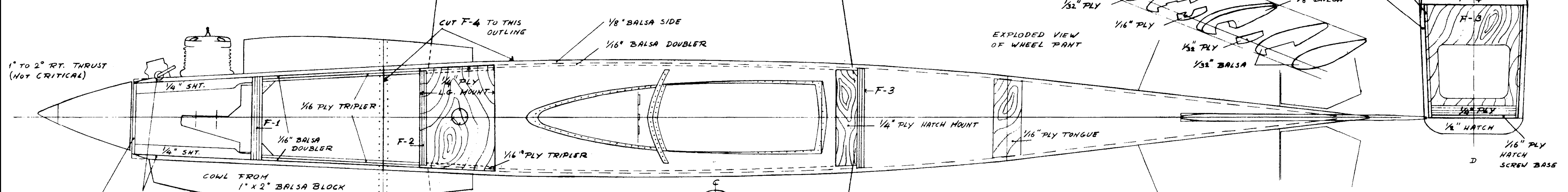

NOTE: DO NOT GLUE JOINTS OF TOP SECTION UNTIL WING IS IN PLACE. SEE X'ED LINES. CUT F-4 & F-5 APART AFTER SHAPING.

NOTE: RUDDER CONTROL IS DEFINITELY AN ADVANTAGE DURING TAKE OFF. SUGGEST BUILDING FOR USEABLE RUDDER - CONNECT TO SERVO OR WORK OFF RIGHT AILERON. AFTER RACER IS FLIGHT TRIMMED - TRY SOME TAKE OFFS WITHOUT RUDDER CONTROL - IF SUCCESSFUL, YOU CAN ELIMINATE CONTROL AND CLOSE RUDDER GAP WITH TAPE.

MISSY DARA
 DESIGNED & DRAWN BY: *Loren Jacobson*
 SPAN: 34 1/2" AREA: 306 SQ. IN.
 LENGTH: 35 1/8" WEIGHT: 2 7/8 LBS.

REAR AS VIEWED FROM OTHER RACERS !!