

SAND BACK OF SHEET FOR EASY REMOVAL OF PARTS THAT STICK

STEP #2

CEMENT SIDES FS TO EITHER SIDE OF FUSELAGE. MOISTEN WITH WATER TO BEND. HOLD IN PLACE WITH PINS UNTIL DRY. CEMENT C1'S IN PLACE TO FORM TOP OF CABIN. BEVEL REAR OF C3 (SEE SIDE VIEW) TO FIT AGAINST FRONT OF C1'S AND ADD C3 AT SAME TIME, TO FORM PROPER ANGLE. ALLOW TO DRY THOROUGHLY. CEMENT TS'S TOGETHER AND INTO NOTCH IN REAR OF D'S. CEMENT T'S BETWEEN SIDES (FLUSH WITH TOP) AGAINST F9. SAND R & R1 AND S & S1 ROUNDING OUTER EDGES. FOR C/L OR A/M FLYING, CEMENT S2 TO BOTTOM OF S1. WHEN DRY ROUND OUTER EDGES. DRILL SMALL HOLES THROUGH PUNCH MARKS IN PLYWOOD BELL-CRANK AND CONTROL-HORN. CEMENT HORN INTO NOTCH IN S1. ASSEMBLE S TO S1 WITH ADHESIVE TAPE, LEAVING 1/16" SPACE BETWEEN UNITS. CEMENT TO FUSELAGE ON TOP OF T LINING UP NOTCHES WITH EACH OTHER. CUT OUT SLOT IN RIGHT REAR SIDE FOR CONTROL ROD. MAKE AND INSTALL CONTROL SYSTEM (SEE NOTE). CEMENT R1, 1/2" TOWARDS RIGHT. CEMENT TO FUSELAGE INSERTING R THROUGH NOTCH IN S AND T. SELECT 1/16" X 3/32" STRIPS FROM STRIP-SHEET AND CEMENT INTO NOTCHES FROM C2 TO F9 ON TOP. (MOISTEN

FUSELAGE CONSTRUCTION

STEP #1

CEMENT REAR OF D'S TOGETHER. CEMENT NOSE LANDING GEAR INTO CREASES BETWEEN F'S (SEE SKETCH). CEMENT F4A FLUSH WITH BOTTOM FRONT OF F4. CEMENT CP1 FLUSH WITH FRONT AND SIDES OF CP. SLIP BULKHEADS INTO NOTCHES BETWEEN D'S, CEMENTING FC BETWEEN F4 AND F6 BEFORE GLUE DRIES. CEMENT CP ASSEMBLY AGAINST FRONT OF F5 FLUSH WITH EDGES OF D'S. CEMENT ASSEMBLED NOSE LANDING GEAR F INTO NOTCHES BETWEEN F1 AND F2.

NOSE LANDING GEAR.

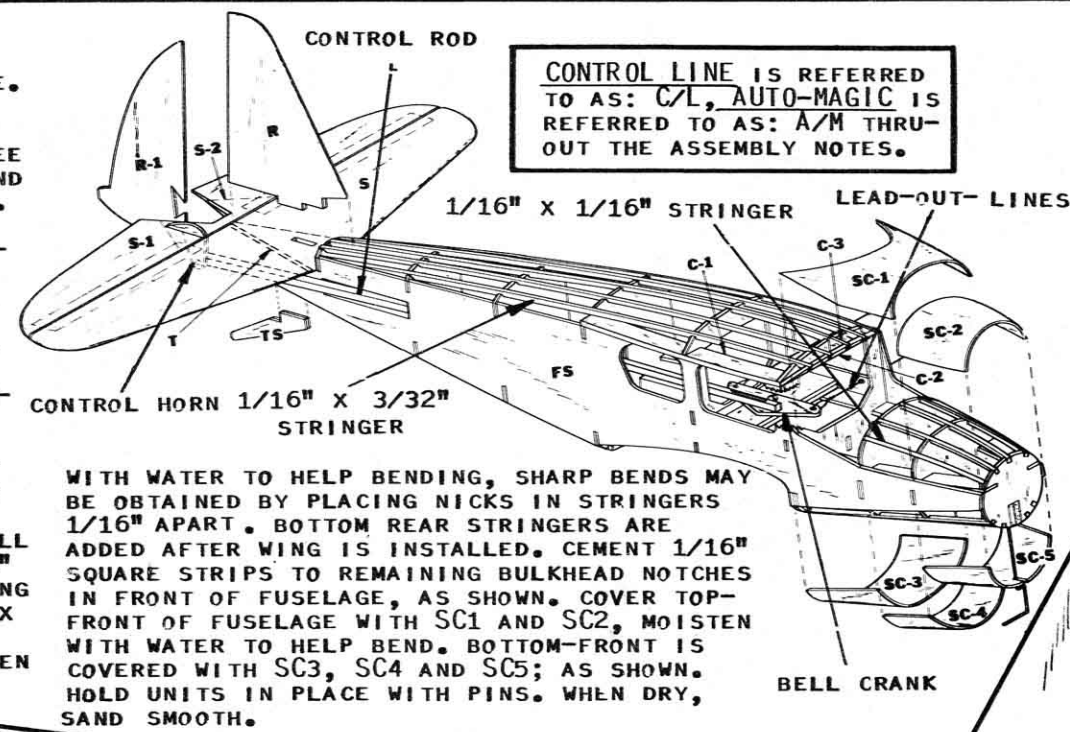

CONTROL LINE IS REFERRED TO AS: C/L, AUTO-MAGIC IS REFERRED TO AS: A/M THROUGHOUT THE ASSEMBLY NOTES.

WITH WATER TO HELP BENDING, SHARP BENDS MAY BE OBTAINED BY PLACING NICKS IN STRINGERS 1/16" APART. BOTTOM REAR STRINGERS ARE ADDED AFTER WING IS INSTALLED. CEMENT 1/16" SQUARE STRIPS TO REMAINING BULKHEAD NOTCHES IN FRONT OF FUSELAGE, AS SHOWN. COVER TOP-FRONT OF FUSELAGE WITH SC1 AND SC2, MOISTEN WITH WATER TO HELP BEND. BOTTOM-FRONT IS COVERED WITH SC3, SC4 AND SC5; AS SHOWN. HOLD UNITS IN PLACE WITH PINS. WHEN DRY, SAND SMOOTH.

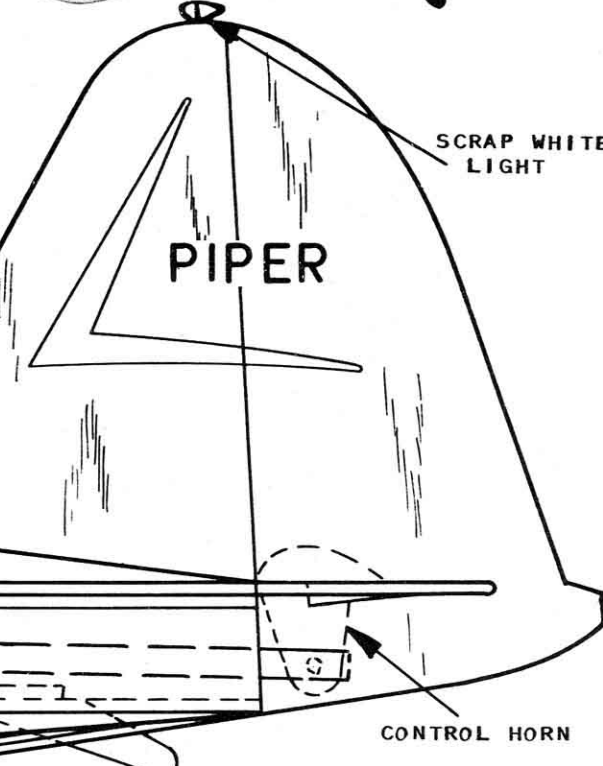
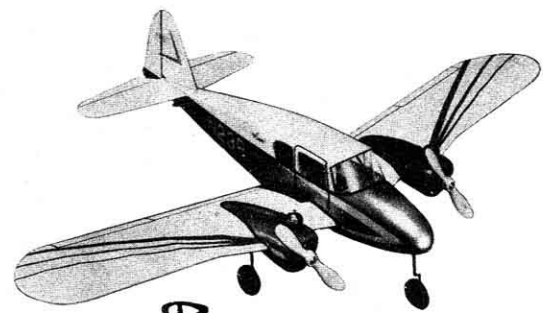

.020 PEE WEE ENGINE

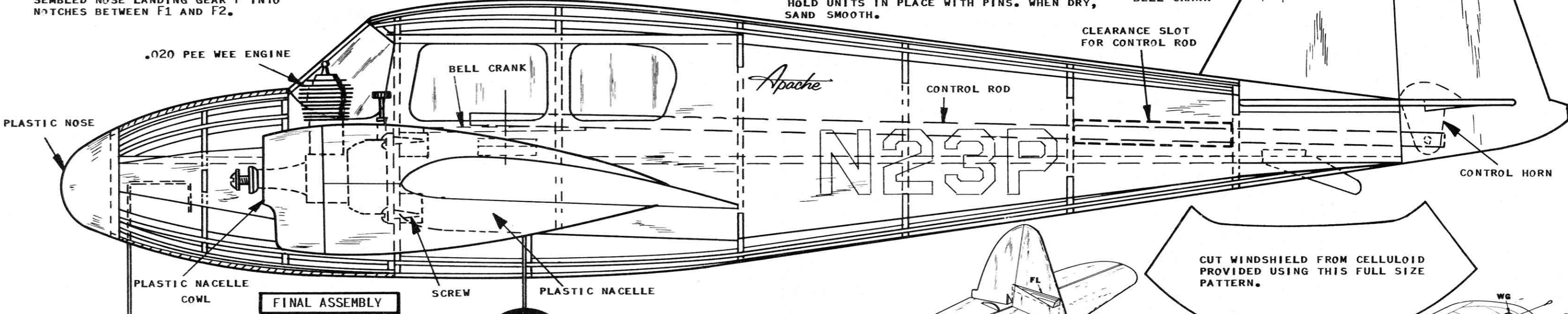

FINAL ASSEMBLY

CEMENT TWO UNITS OF FOUR FL'S TOGETHER. SAND TO SHAPE AND CEMENT TO EITHER SIDE OF RUDDER. CEMENT FINISHED WING INTO BOTTOM OF FUSELAGE. CENTER RIB IS CEMENTED TO RIGHT HAND SIDE OF FC. BE CERTAIN THAT LEADING & TRAILING EDGE AND BOTH SPARS REST UP AGAINST NOTCHES IN BOTTOM OF FC. OTHERWISE MODEL WILL NOT FLY PROPERLY. ALLOW TO DRY THOROUGHLY. CEMENT F5A TO BOTTOM OF WING, DIRECTLY UNDER CENTER OF GUSSET W13. CEMENT 1/16" X 3/32" STRINGERS INTO NOTCHES IN BOTTOM BULKHEADS FROM F4 TO REAR OF FUSELAGE. STRINGERS EXTEND PAST F9A AND ARE CUT OFF AT ANGLE AND CEMENTED TO TS AND BOTTOM OF D'S WHERE THEY MEET COVER FUSELAGE WITH TISSUE APPLIED WET. GIVE ALL WOOD AND TISSUE PARTS TWO COATS OF CLEAR DOPE. USING TINY WOOD SCREWS, SECURE ENGINE TO EACH MOTOR MOUNT. CUT MOLDED NACELLE HALVES (TOP AND BOTTOM) FROM PLASTIC SHEET AND CEMENT OVER NACELLE FRAME. CAUTION: NACELLE HALVES ARE LEFT AND RIGHT AND WILL NOT FIT UNLESS THEY ARE USED ON PROPER SIDE. PLASTIC MAY BE TRIMMED SMOOTH WITH SAND PAPER.

TRIM FRONT FLUSH WITH A2. CUT MOLDED NACELLE-COWLS FROM PLASTIC SHEET AND TRIM OUT ALL HOLES. CUT TOP AWAY TO FIT AROUND ENGINE (1/16" CLEARANCE) AND CEMENT IN PLACE. CUT OUT MOLDED NOSE AND CEMENT TO FRONT OF FUSELAGE. CEMENT THE FOUR WF'S IN PLACE ON EITHER SIDE OF NACELLES AS SHOWN. WHEN DRY, ROUND OFF FRONT, AND APPLY TWO COATS OF CLEAR DOPE. COLOR SCHEME IS OPTIONAL. ORIGINAL MODEL PAINTED WHITE WINGS, TAIL, UPPER FUSELAGE; RED NACELLES AND LOWER FUSELAGE. WHEELS AND TRIM BLACK. DIMPLE IN NOSE IS LANDING LIGHT, PAINT SILVER. SLIP WHEELS ON AXLES AND SECURE WITH DROP OF SOLDER. BE CERTAIN WHEELS SPIN FREELY. FISH LEAD-OUT LINES THROUGH CABIN SIDE AND NOTCHES IN WG, TIEING LOOPS FOR FLYING LINES. CHECK THAT CONTROLS OPERATE FREELY. SOAK DECALS IN WATER AND SLIDE INTO POSITION ON MODEL. CEMENT CELLULOID TO BOTH SIDES OF CABIN. ROUND OFF 1/16" SQUARE BALSA AND CEMENT TO CENTER STRINGER FROM TOP OF CABIN TO F3. CUT OUT WINDSHIELD AND CEMENT IN PLACE. ADD SCALE AILERON, ELEVATOR AND RUDDER MARKINGS, WITH INDIA INK OR BLACK SCOTCH TAPE CUT 1/32" WIDE. SEE NOTE FOR A/M FLYING. GOOD LUCK!!! GOOD FLYING!!!

CUT WINDSHIELD FROM CELLULOID PROVIDED USING THIS FULL SIZE PATTERN.

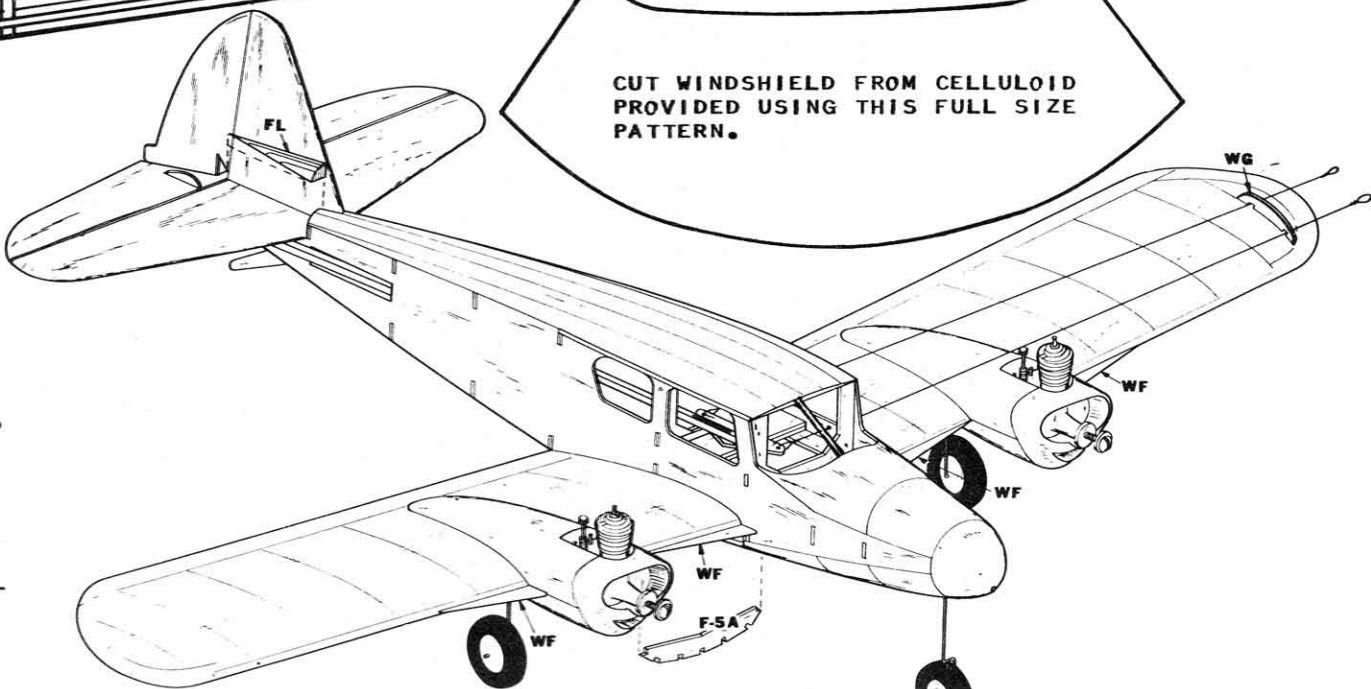

KIT #M-4 PIPER APACHE 23 1/2" Span

*.020 Engine Only Recommended for Control Line or "Auto-Magic" Pilot

Sterling models Phila. Pa., U.S.A.

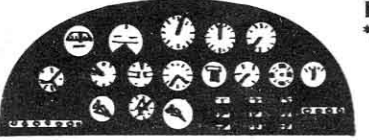

CUT OUT INSTRUMENT PANEL. CEMENT TO F3

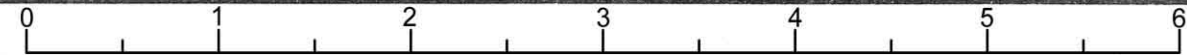
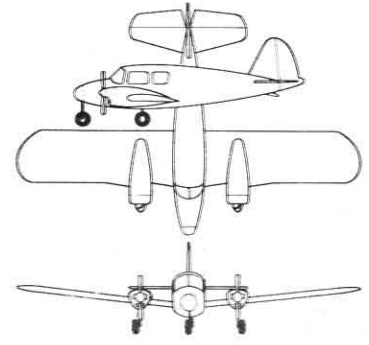

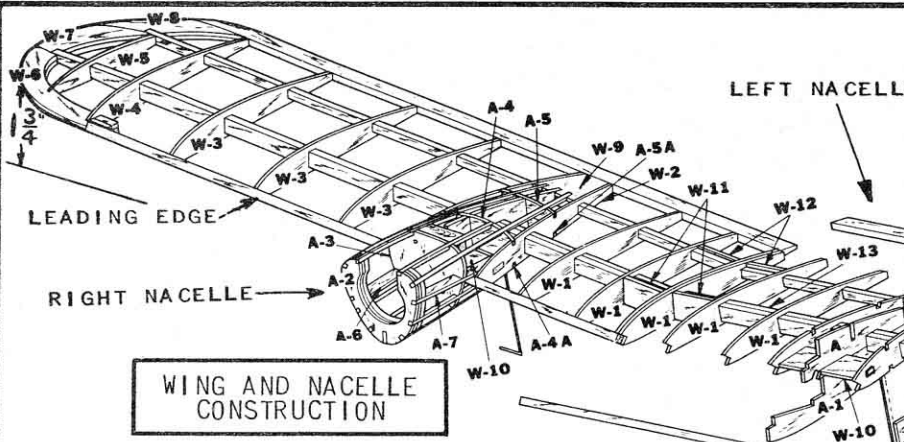

WING AND NACELLE CONSTRUCTION

BUILD WING HALVES ON PLAN USING WAX PAPER TO PREVENT FRAME FROM STICKING. PREPARE SPARS (SEE NOTE). CEMENT DOUBLE LAYER WING TIP SECTION TOGETHER AS SHOWN. PIN DOWN TRAILING EDGE. POSITION RIBS ON SPARS, OMITTING END RIB W1. (CAUTION! DON'T CEMENT RIBS TO SPARS UNTIL WING IS ASSEMBLED.) INSERT W9'S BETWEEN ANGLED RIBS W12 ONE ON TOP AND ONE ON BOTTOM OF REAR SPAR, AND CEMENT RIBS TO TRAILING EDGE. INSERT W10 BETWEEN ANGLED RIBS AND CEMENT LEADING EDGE TO FRONT OF RIBS. RIBS SHOULD BE VERTICAL. CEMENT WING TIP SECTIONS TOGETHER AND IN PLACE, RAISING TIP FLUSH WITH SPARS. CEMENT W11 TO FRONT SPAR AND W12 TO REAR SPAR, FLAT AGAINST RIB. END RIB W1 IS CEMENTED IN PLACE, AGAINST ANGLES. BUILD OPPOSITE WING HALF IN SAME MANNER, AND ALLOW TO DRY THOROUGHLY. WHEN DRY, SAND WING TIPS ROUND TO BLEND SMOOTHLY INTO LEADING AND TRAILING EDGE. CEMENT WING HALVES TOGETHER; AT THE SAME TIME CEMENT LANDING GEAR INTO CREASE FOR SAME IN DIHEDRAL GUSSET W13. INSERT INTO NOTCHES IN BOTTOM OF RIBS WITH LANDING GEAR AGAINST SPAR. TOP OF W13 AND WING SPARS SHOULD BE FLUSH. THIS WILL ALLOW WING TO ASSUME THE PROPER (DIHEDRAL) ANGLE WHEN VIEWED FROM FRONT. PINS MAY BE USED TO HOLD ASSEMBLY. CHECK FOR WARPS WHILE DRYING. CONSTRUCT NACELLE BY CEMENTING A & A1 INTO NOTCHES IN W9 & W10. NACELLE BUILT ON RIGHT-HAND WING-HALF, MUST HAVE PRINTED BULKHEAD NUMBERS FACING FORWARD. OPPOSITE NACELLE HAS PRINTED BULKHEAD NUMBERS FACING TOWARDS REAR. CEMENT BULKHEAD A4 & A5 INTO NOTCHES ACROSS TOP, AND A4A & A5A ACROSS BOTTOM. CEMENT A3 TO FRONT OF NACELLE AGAINST LEADING EDGE. CEMENT HARDWOOD MOTOR MOUNTS TO REAR OF A7 (IN CENTER), BOTTOM THROUGH NOTCH IN A1, AGAINST LEADING EDGE; TOP THROUGH CUT-OUT IN A. USE TWO HEAVY COATS OF CEMENT AND ALLOW TO DRY THOROUGHLY. MAKE TWO NOSE BULKHEAD UNITS BY CEMENTING THREE A2'S TOGETHER, THICKER ONE TOWARD REAR. CEMENT A7 (ON SIDE TOWARDS CENTER OF WING) INTO NOTCH IN A3, OVER LEADING EDGE, AGAINST W2 AND A4. CEMENT A6 ON OPPOSITE SIDE UNDER LEADING EDGE. CEMENT ASSEMBLED A2 TO FRONT OF NACELLE AND ALLOW UNIT TO DRY THOROUGHLY. CEMENT A8 AGAINST A1, BETWEEN A4A & A5A. CREASE FITS OVER LANDING GEAR. CEMENT 1/16" SQUARE STRINGERS (FROM STRIP-SHEET) INTO NOTCHES IN BULKHEADS AS SHOWN. BUILD OPPOSITE NACELLE IN SAME MANNER. COVER EACH WING HALF WITH TISSUE PROVIDED, APPLIED WET. APPLY TWO COATS OF CLEAR DOPE, CHECKING STRUCTURE CONSTANTLY AGAINST WARPS. IF WARP OCCURS - APPLY CLEAR DOPE AND TWIST IN OPPOSITE DIRECTION, UNTIL DRY. WING INSTALLED IN FINAL ASSEMBLY.

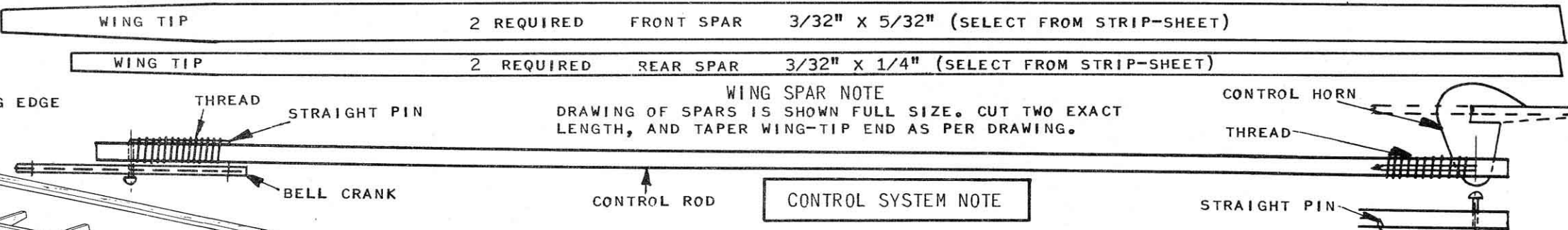

WING SPAR NOTE
DRAWING OF SPARS IS SHOWN FULL SIZE. CUT TWO EXACT LENGTH, AND TAPER WING-TIP END AS PER DRAWING.

CONTROL SYSTEM NOTE
HOLE FOR HORN THEN REMOVE. PLACE ROD IN FUSELAGE INSERTING THROUGH HOLES IN BULKHEADS. SECURE BELL CRANK TO CP ASSEMBLY WITH SMALL MACHINE SCREW. PLACE WASHER BETWEEN BELL CRANK AND CP1. SLIP WASHER AND TWO NUTS ON PROTRUDING MACHINE SCREW. RUN NUTS CLOSE TO CP (SO THAT BELL CRANK MOVES EASILY) AND TIGHTEN TOWARDS EACH OTHER. A COAT OF CEMENT OR DROP OF SOLDER WILL PREVENT NUTS FROM LOOSENING. INSERT PIN THROUGH CONTROL HORN AND HOLE MADE IN ROD. BEND OVER, AND SECURE IN SAME MANNER AS FRONT PIN. MOVEMENT OF BELL CRANK SHOULD MOVE ELEVATOR UP AND DOWN FREELY AND EASILY. ANY STICKING TENDENCIES MUST BE REMOVED. TIE A LENGTH OF NYLON (OR STRONG THREAD) LINES TO HOLE ON BOTH SIDES OF BELL CRANK. KNOTS WILL BE TIED AFTER WING GUIDE (WG) IS INSTALLED IN FINAL ASSEMBLY.

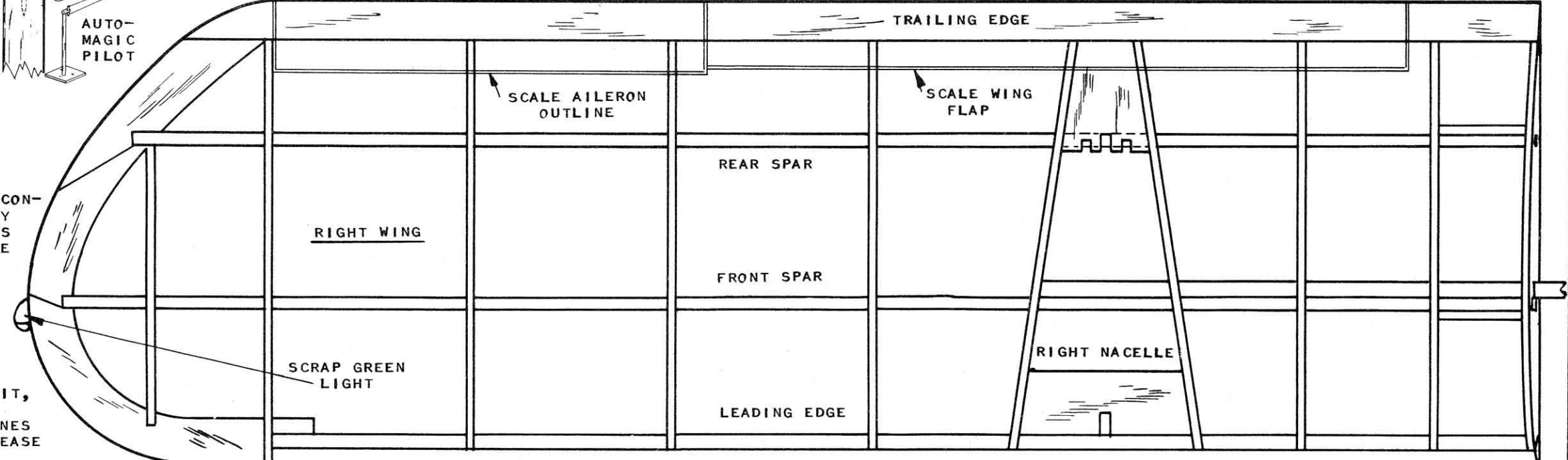
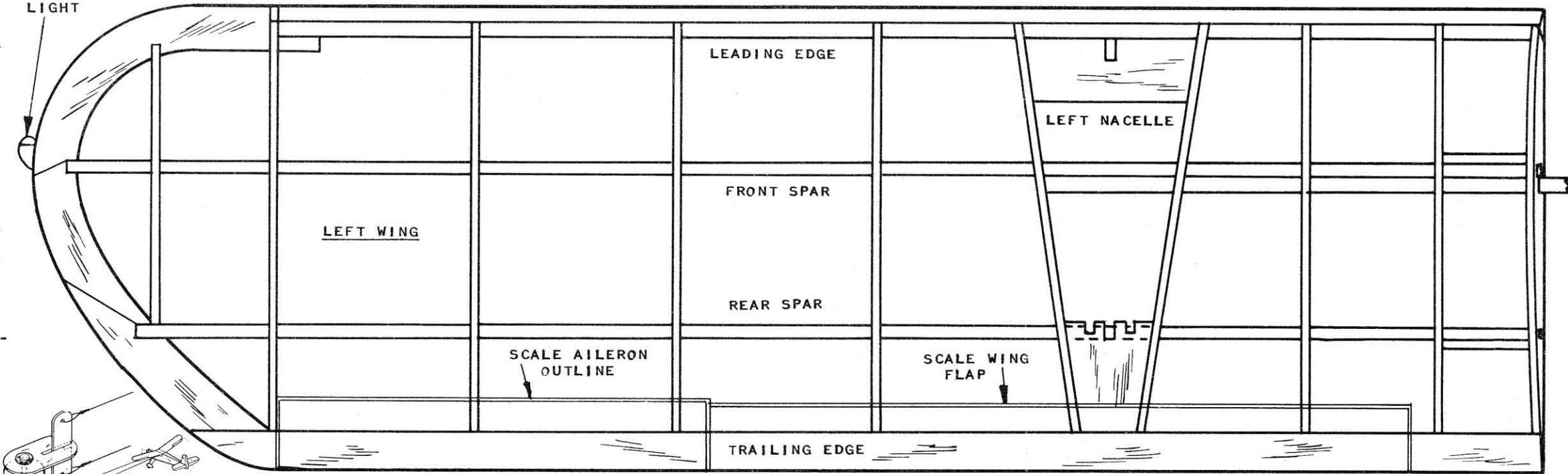

AUTO-MAGIC PILOT FLYING

NEW METHOD OF CAPTIVE FLYING FOR SMALL AREAS MAKES HAND CONTROLLING AS IN U-CONTROL UNNECESSARY. MODEL AUTOMATICALLY FLIES TO PRE-DETERMINED HEIGHT UNTIL GRACEFUL LANDING IS MADE. INSTALL CONTROL SYSTEM (SEE NOTE). DRILL SMALL HOLE (IN VERTICAL) AND LARGE HOLE (IN HORIZONTAL) PLYWOOD A/M UNITS AND CEMENT TOGETHER. SECURE A POST (BROOMSTICK) ABOUT 4 FT. HIGH. DRIVE INTO GROUND OR NAIL TO BOARD, WEIGHTING SAME TO PREVENT POST FROM SHIFTING. FASTEN A/M PILOT UNIT TO TOP OF POST WITH NAIL. BE CERTAIN HOLE IS LARGE ENOUGH TO SWING FREELY. USE WASHERS ABOVE AND BELOW. TIE 12 TO 15 FT. NYLON (OR STRONG THREAD) LINES FROM A/M UNIT TO LINES IN MODEL. LINES ARE SAME LENGTH, SO THAT WHEN TAUT AND MODEL HELD AT SAME LEVEL AS A/M UNIT, ELEVATOR IS NEUTRAL. WHEN MODEL IS LOWERED ELEVATOR GOES UP; RAISED, ELEVATOR GOES DOWN. TO FLY MODEL, START ENGINES PULL MODEL AWAY FROM POST UNTIL LINES ARE TAUT, THEN RELEASE FOR TAKE OFF. GOOD LUCK!!! GOOD FLYING!!!

