

FUSELAGE ASSEMBLY

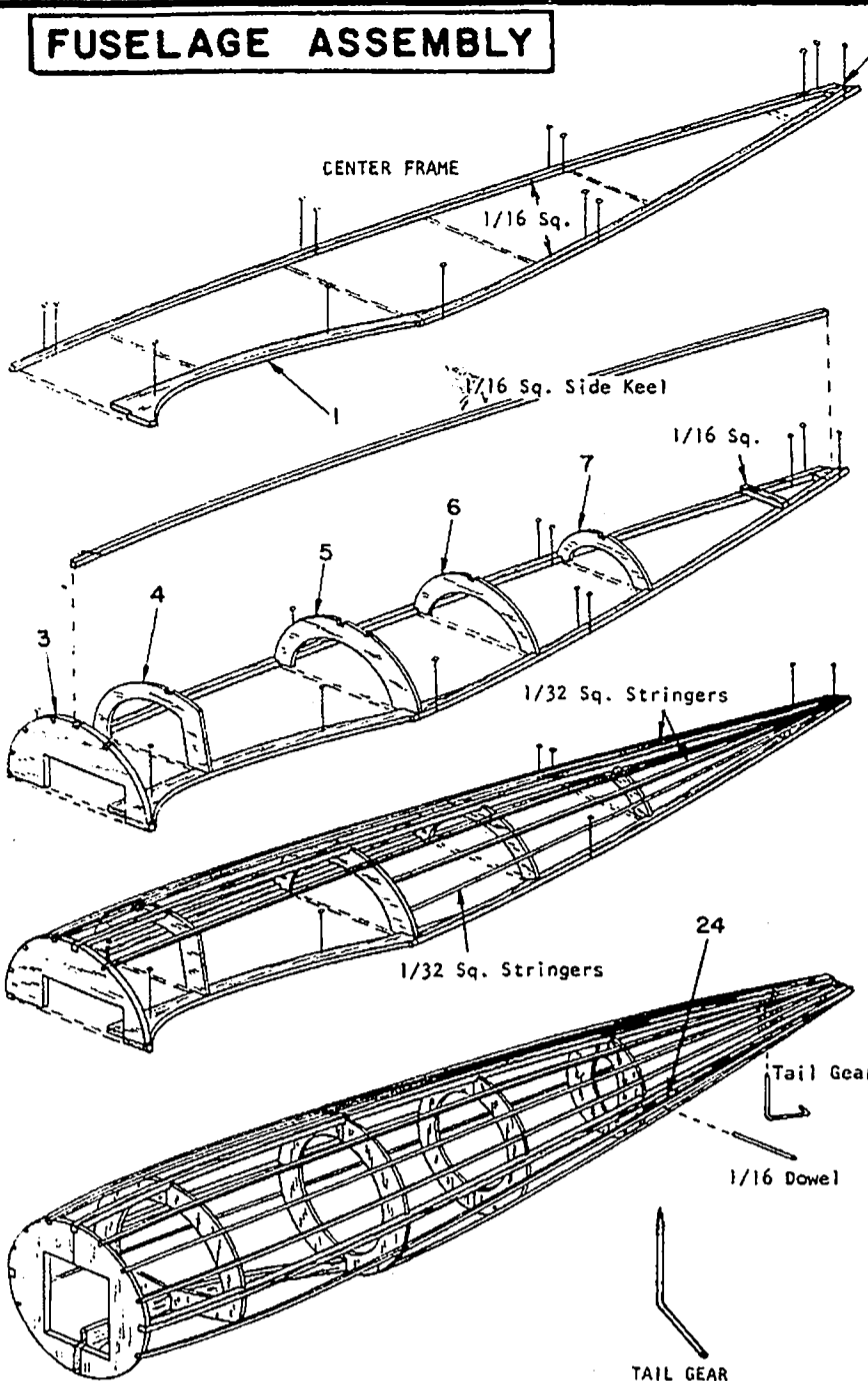

STEP 1

Remove any creases in plan. Tape down to building board, and cover with kitchen film to prevent frame from sticking to plan. Printed parts may all be cut out before construction is started. Using wire provided, bend landing gears to shape of full-size pattern. Solid black lines on full-size side view is the fuselage center frame. Cut 1/16" square strips carefully to length, pin & cement in place. Add parts #1 & #2. Allow center frame to dry thoroughly.

STEP 2

Step 2 and Step 3 should be done one after the other to prevent glue from setting permanently before parts are aligned. Cement all Bulkhead halves from #3 thru #7 vertically in place, then cement 1/16" sq. side strip in place followed by 1/16" sq. side keel into slots in Bulkheads as shown.

STEP 3

Note that Side Keel (as well as stringers that will be installed) are in many cases past edge of Bulkhead, as shown in sketches. Using the 1/32 printed parts sheet cut six 1/32 sq. stringers 10 inches long. Install the 1/32 sq. stringers as shown in sketch, photo and side view. Any of the top stringers not visible in this Step Sketch can be seen in next Step Sketch. Allow framework to dry thoroughly.

STEP 4

Remove frame from flat surface and cement opposite side of Bulkheads in place, followed by 1/16 sq. side keel as described in Steps 2 and 3 (DO NOT MAKE ANOTHER FUSELAGE CENTER FRAME ASSEMBLY). These Bulkhead halves are cemented to the fuselage frame you have just removed from the flat surface. Complete right side of fuselage in same manner as left then cement #24's to either side at location shown. Clip off head of straight pin, bend tail gear in place as shown in sketch and Side View. Check Fuselage Assembly with Top View to be certain fuselage is aligned properly. Also check from front and rear to be sure fuselage is not distorted. 1/16" Dowel which holds rubber motor at rear is shown in this sketch for clarity only, it is installed in Final Assembly. When framework is thoroughly dry, sand lightly to prepare for tissue covering.

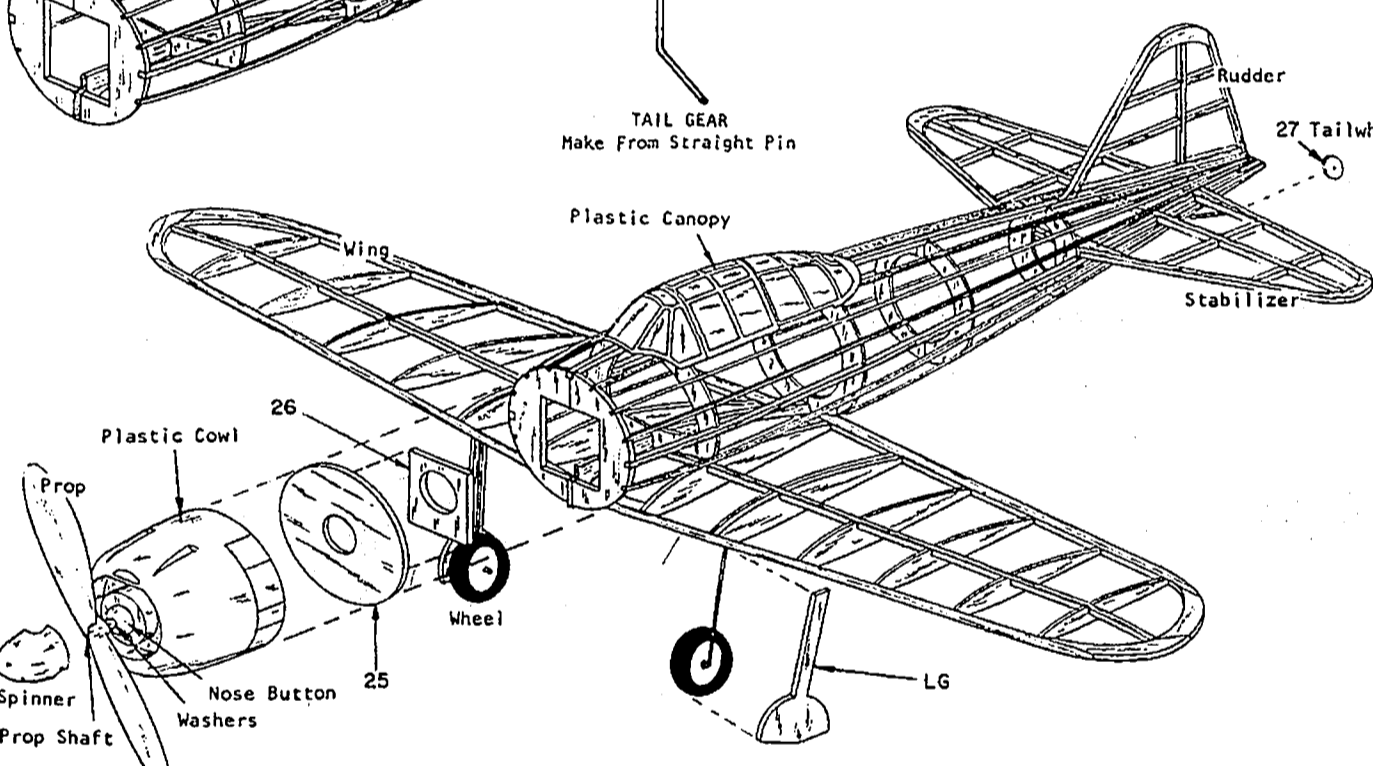

FINAL ASSEMBLY

Although sketch shows model uncovered, all components are actually covered (as described in Covering Note) before assembling model. Clear out stab slot at rear of fuselage and slip stab in place. Check alignment of stab and cement in place. Cement rudder vertically in place on top of fuselage. Check again being certain stab is horizontal and rudder is vertical. Cement wing in place against bottom of fuselage, checking alignment carefully. Cement LG's to outside of wire landing gears. Place #25 into corresponding cut-out in #3, trimming if necessary for snug fit. Apply a coat of cement to front of #26 ONLY then put #25 in place, aligning with #3 pressing #25 against #26. When cement is dry remove assembled #26 & #25. Cut Cowl from plastic sheet. Place assembled #25 & #26 on flat surface, #26 down. Push rear of Cowl over assembly so that #25 is flush with rear of Cowl and #26 extends 1/16" behind. Cement in place with very light coats of wood model airplane cement to prevent distortion. Cut the paper wing fairings from plan and install front fairing first, when dry, roll rear top fairing over edge of board to create a rounded fairing and cement in place as shown on Side View and photo of finished model.

FLIGHT INSTRUCTIONS

DO NOT ATTEMPT TO FLY MODEL UNTIL BALANCE (AT ARROW SHOWN ON SIDE VIEW) HAS BEEN ACHIEVED! ADD WEIGHT TO FRONT OR BACK IF NECESSARY. Check wing and tail. If warps have developed, remove using steam method described in Covering Note. Model is now ready. Pick a calm day for test-flying. Wind propeller clockwise, release propeller, then gently launch into any prevailing wind, slightly nose down at a point on the ground about 50 ft. ahead of you. If model noses up and then falls off and stalls (AFTER MODEL WAS BALANCED), bend elevators down slightly, using hot breath in same manner as steam. If model dives, bend elevators up. If model veers too much to one side, bend rudder to opposite side. If model glides well but stalls, dives, or turns under power; cement 1/16" balsa shim to front

bulkhead which will angle cowl to opposite direction, (down or side thrust). Increase or decrease shim thickness as necessary. Take-offs require more power and therefore more turns in rubber motor. For longer flights and competition, it is recommended that model lubricant (available at most hobby shops) be used. Apply lubricant sparingly. Use winder, (Sterling Models Rubber Winder is highly recommended, it is available at your Dealer at a very reasonable price.) To store winds in motor, stretch rubber out 3 to 5 times original length, then proceed to wind, moving slowly back to model. Feel rubber from time to time to be certain that it does not get so taut that it breaks. Upon reaching nose, motor should be completely wound. GOOD LUCK AND GOOD FLYING!

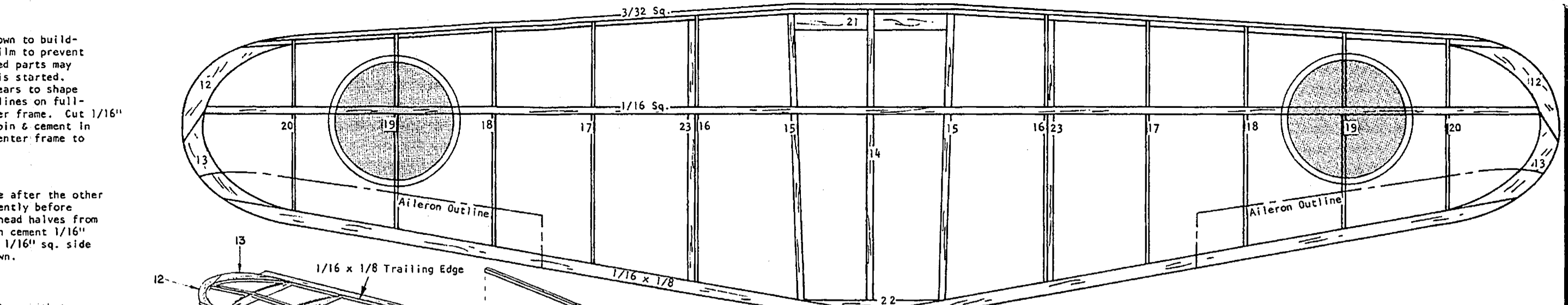

WING ASSEMBLY

STEP 1

Assemble both wing tips by cementing #12 & #13 together over plan. Remove when dry. Pin #22 in place over plan. Cut 1/16" x 1/8" trailing edges to shape and pin to plan, then cement assembled tips to trailing edge. Cement all ribs vertically in place in numerical order shown. Cement #21 into notches in front of Ribs #14 & #15's. Cut 3/32" square leading edge to length and cement to front of ribs and tips. See that ribs remain vertical and in line with ribs on drawing. 1/16" square spars are now added to notches in top of ribs as shown. All cemented in place except at center rib #14, which must be free to move when installing dihedral in next step. Spars are cracked at rib #20 to angle down fitting flush within tip. Allow wing frame to dry thoroughly.

STEP 2

Using your sharp razor blade, cut completely through leading and trailing edges at center rib #14, thus separating panels. Keep center pinned down, raising tips 15/16" as shown for dihedral. Cement the Left and Right hand landing gears to outside of Ribs #16 and immediately cement Ribs #23 to outside of #16's sandwiching gears between. Entire wing is permitted to dry THOROUGHLY. When dry, sand frame smooth rounding trailing edge and tips into leading edge.

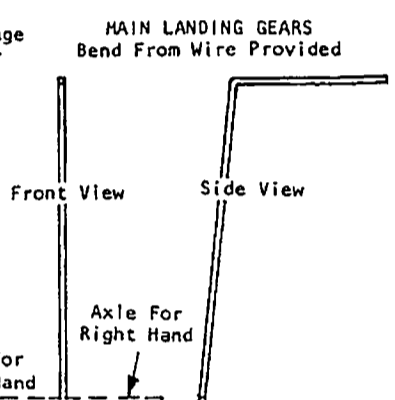
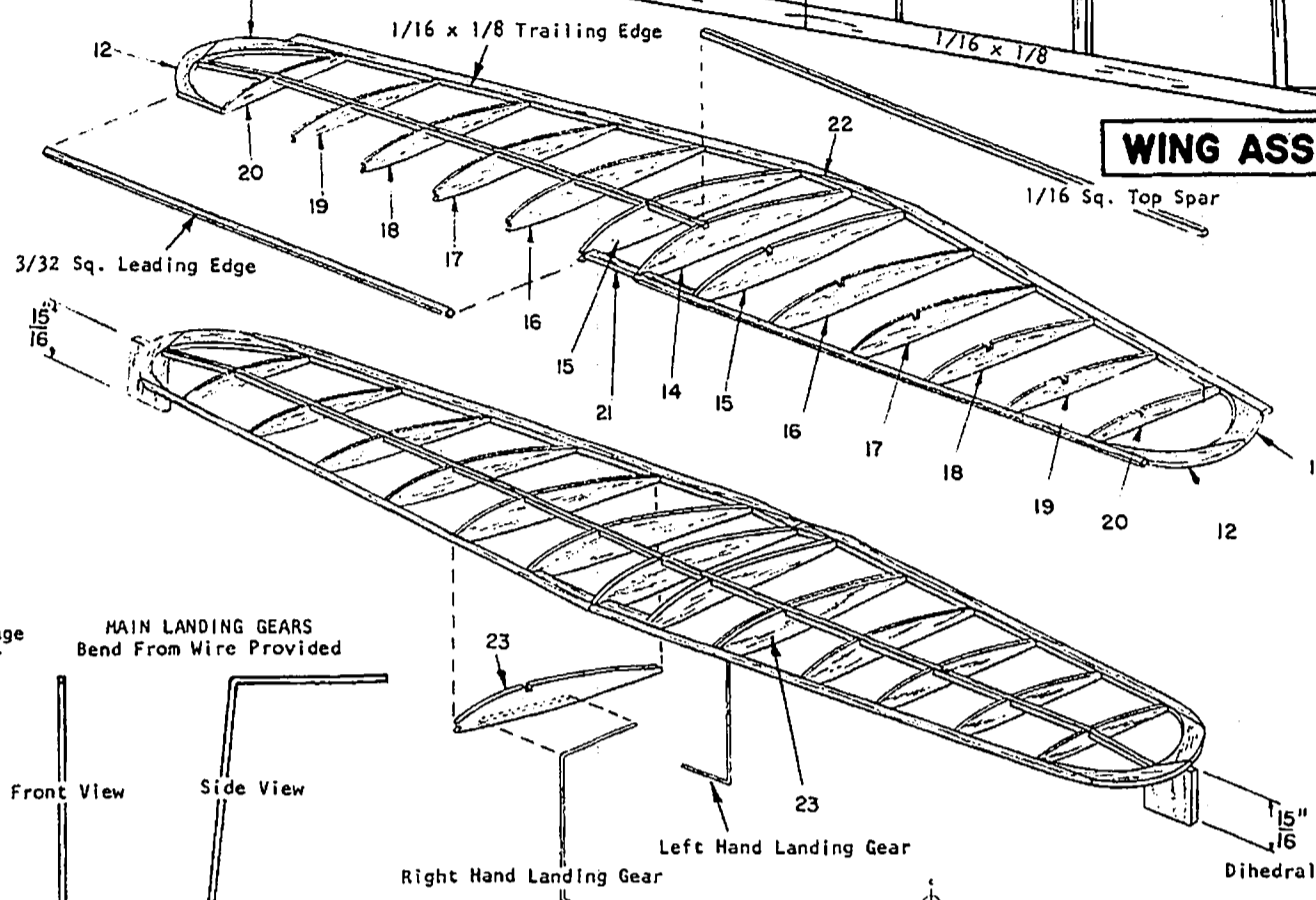

TISSUE COVERING

Frame is covered tissue dry. Use clear dope to attach tissue. Apply a light coat of dope to the outside edges of the area to be covered and allow to dry. Cut tissue to shape required, about 1/4" oversize all around. Apply a second coat of dope to the frame, then put the tissue in place smoothing into frame and working out any wrinkles. When dry, excess tissue is trimmed off with sharp blade. If any wrinkles develop, cut out wrinkled area (bounded by nearest framework) and recover section. COVER BOTTOM OF WING using 1 piece for each panel: Cover top of wing using 1 piece for each panel. If any problem of wrinkles is encountered on tips, use separate pieces of tissue. COVER STAB AND RUDDER with single piece of tissue for each side. COVER FUSELAGE using as many pieces of tissue as required to avoid wrinkling. Using a fine spray (such as from a perfume atomizer) spray tissue lightly with water to shrink. BE SURE TOP AND BOTTOM ARE SPRAYED AT THE SAME TIME! Set aside to dry on end, so that it is surrounded by air permitting equal drying. This should prevent warps. Apply 3 coats of clear dope thinned with equal parts of thinner (50/50). Apply to top and bottom of surfaces AT SAME TIME and allow to dry in same manner. Check that wing and tail surfaces are free of warps before assembling. Warps can be removed by holding over steam (from boiling kettle) and twisting gently in opposite direction. Hold until cool and check again. Model is now ready to be assembled as described in Final Assembly.

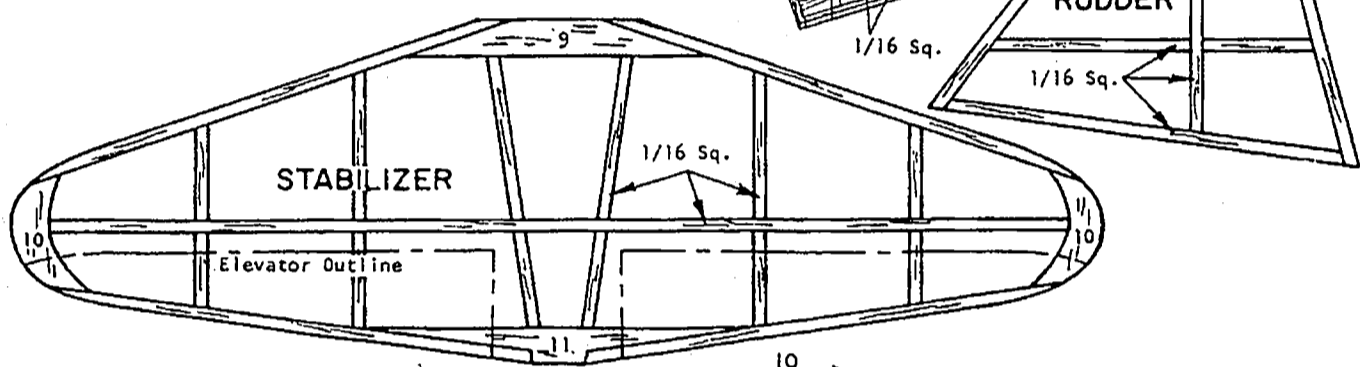
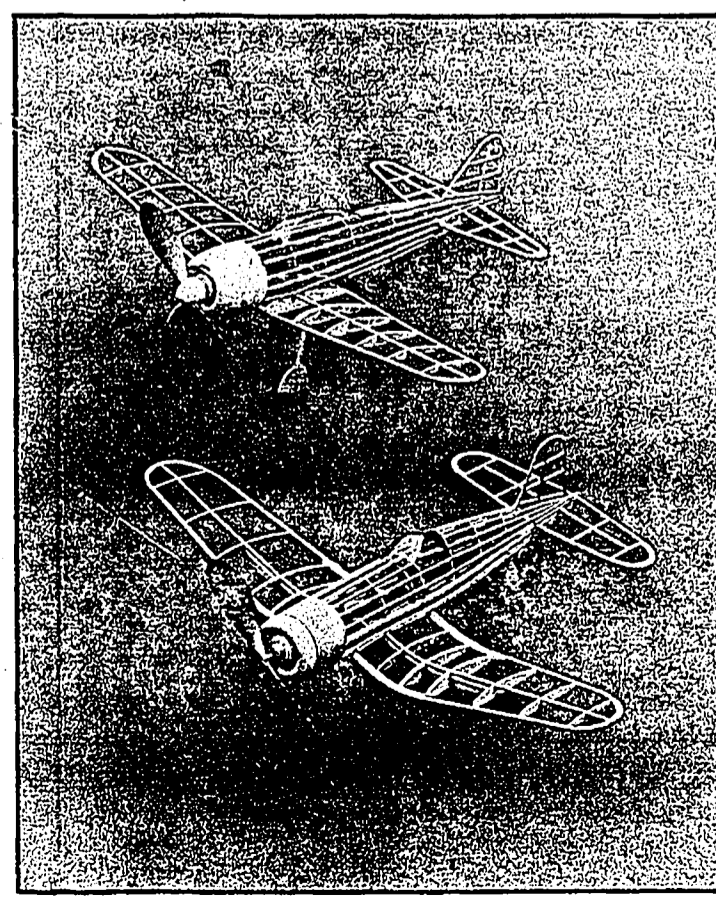

TAIL ASSEMBLY

Pin and cement number parts together over plan. Complete assemblies by adding 1/16" square strips cut to fit, and cement in place. Allow frames to dry thoroughly before removing from flat surface then sand smooth, rounding edges. Cover as described in Covering Note.

SCALE DETAILS AND SPECIFICATIONS

Wing Span 36' 1" Length 29' 9" Height 9' 2"
 Engine Sakae 21, 1130 HP 14 Cyl. Maximum Speed 347 MPH
 Armament 2 20mm Cannon in Wings
 2 7.7mm Machine Guns in Fuselage

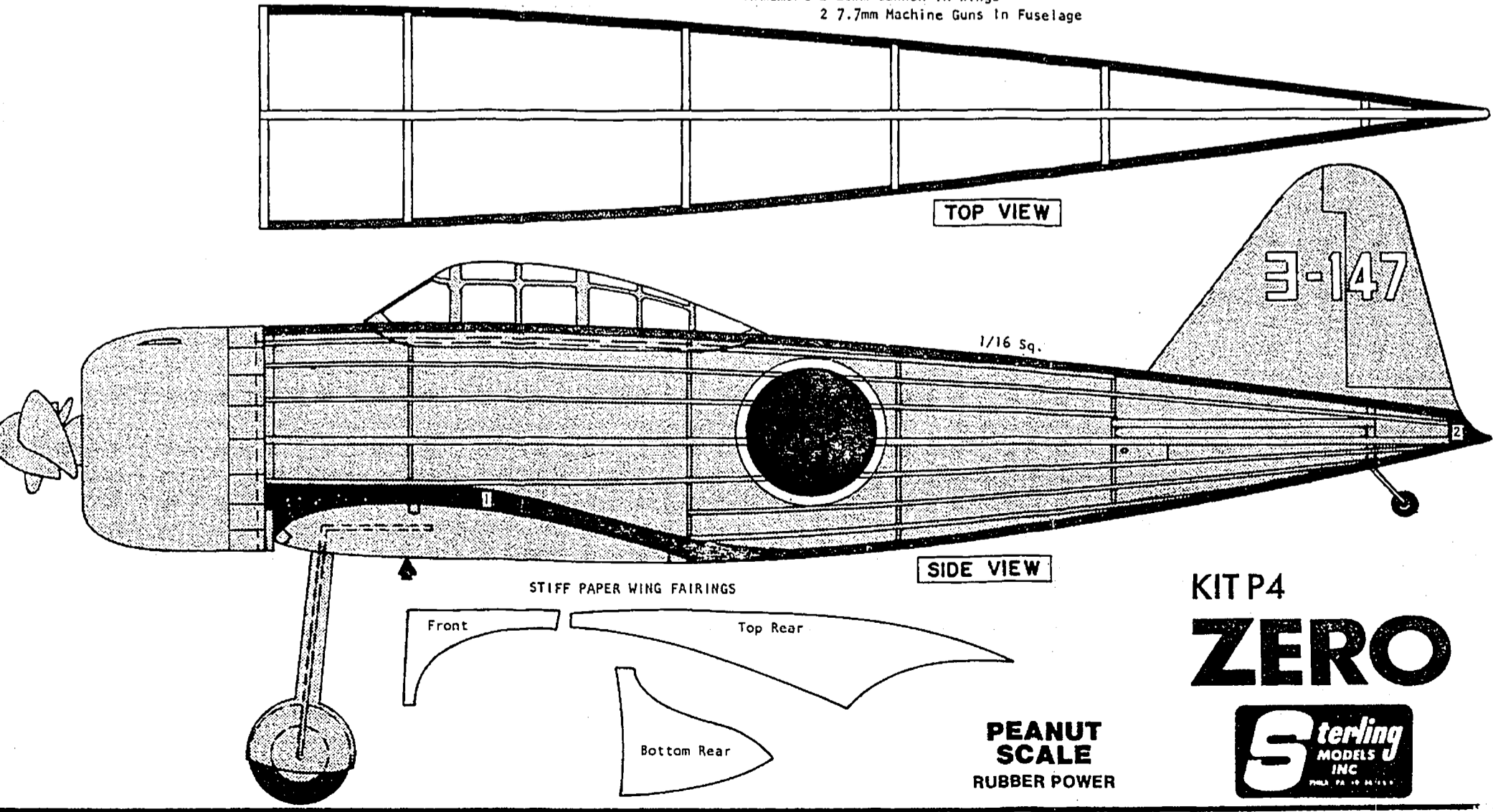

KIT P4
ZERO
 PEANUT SCALE
 RUBBER POWER
 Sterling Models, Inc.