

FUSELAGE ASSEMBLY

STEP 1

Important--Be sure to read Introductory Note on other side of plan before starting assembly of this model. Remove any creases in plan. Tape down to building board, and cover with Saran Wrap to prevent frame from sticking to plan. Printed parts may all be cut out before construction is started. Using wire provided, bend landing gear to shape of full-size pattern. Gear is now cemented between bulkheads #28 & #29, as shown on dotted location. Solid black lines on full-size side view is the fuselage side frame. Cut 1/16" square strips carefully to length, pin & cement in place. Add parts #25 and #26. Allow side frame to dry before removing from board, then build another identical side frame.

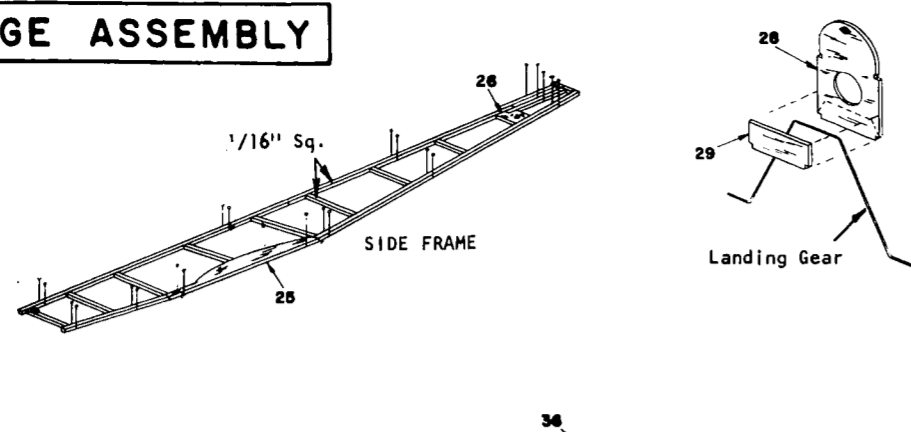

STEP 2

Assemble fuselage sides by cementing them together at rear. Be certain ends are perfectly flush with each other, then cement bulkhead #27 to front as shown. Allow to dry then cut cross-members to length shown in solid lines on top view. Cement them in place on bottom of fuselage with the corresponding bulkheads #30 to #36 on top. Landing gear bulkhead #28/29 is installed as shown. Work from front to rear, holding sides together with tape where necessary. Check assembly with top view to be certain fuselage is aligned properly. Also check from front and rear to be sure fuselage is square and not distorted. Allow to dry thoroughly.

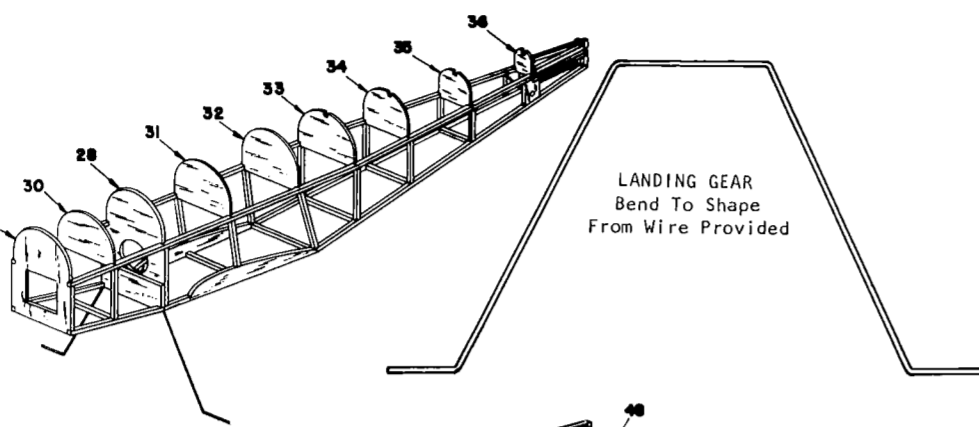

STEP 3

Moisten top cover #37 with warm water to aid in bending and cement it in place to top of fuselage as shown. Hold in place with tape until dry. Using the 1/32 printed parts sheet cut six 1/32 sq. stringers 4-1/4" long. Install 1/16 sq. center stringer into notches from #33 to rear then cement the 1/32 sq. stringers in place as shown, three on each side. Allow to dry thoroughly. Carefully sand entire fuselage to prepare for tissue covering. Tail skid #48 is cemented in place as shown on sketch and side view AFTER fuselage is covered.

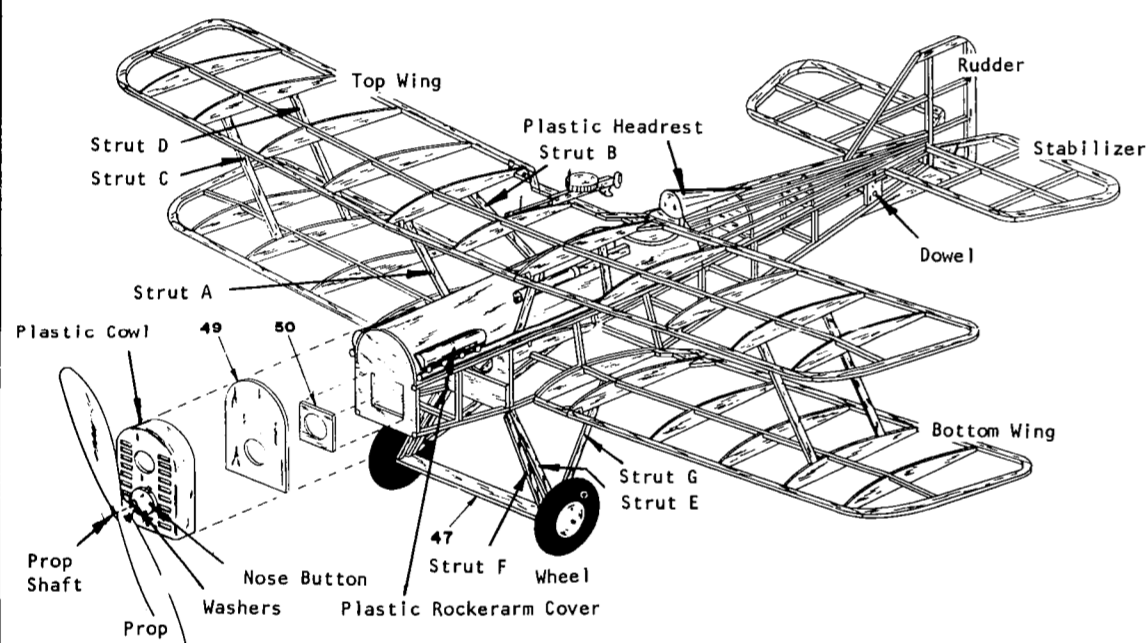
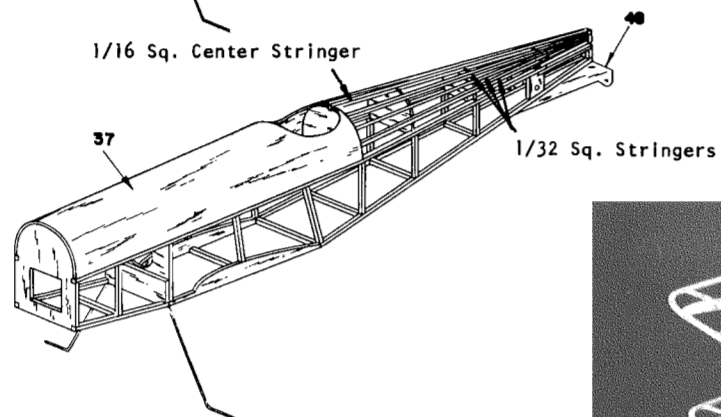

FINAL ASSEMBLY

Although sketch shows model uncovered, all components are actually covered (as described in Covering Note) before assembling model. Cut 1/16 sq. from stab slot then cement stabilizer and rudder to rear of fuselage, being certain stab is horizontal, rudder vertical. Top wing is assembled to fuselage by cutting a wing template from cardboard using pattern provided. Pin template to top center of fuselage and set wire in place (centered). Cement wing struts A and B in place on each side as shown in sketch and side view. Check that wing is aligned properly and allow to dry. Cement bottom wing panels to #25 on sides of fuselage flush with bottom and immediately cement outer struts C & D in place as shown. Check alignment carefully and allow to dry then remove cardboard template. Cement landing gear strut E to back of wire landing gear. Push dowel thru hole in #47 to bottom of landing gear struts and axles. Be certain it is aligned properly as shown in sketch and side view and allow to dry. Cement front landing gear struts F in place and do likewise with rear struts G as shown in sketch and side view. Slip wheels on axles and add a drop of cement to protruding axle to secure wheels. Place #50 into corresponding cut-out in #27, trimming if necessary for snug fit. Apply a coat of cement to front of #50 ONLY then put #49 in place, aligning with #27, pressing #50 against #49. When cement is dry remove assembled #49 & #50. Cut cowl from plastic sheet. Place assembled #49 & #50 on flat surface, #50 down.

Push rear of cowl over assembly so that #50 is flush with rear of cowl and #49 is recessed 1/16" within cowl. Cement in place with VERY LIGHT COATS of wood model airplane cement to prevent distortion. Using celluloid provided, cut windshield to pattern shape and cement in place. Cut headrest and rocker arm covers from plastic sheet and cement in place with light coat of model airplane cement. Slip nose button on propeller shaft, followed by the two washers. Insert shaft through rear of prop and make a 90° bend in end of shaft to engage prop. Install rubber loop by dropping thru fuselage. Push dowel thru hole in #26, thru rubber loop and into hole in opposite #26, thus capturing rubber. Bend wire hook out of paper clip and pull rubber loop out of fuselage and engage in propeller shaft hook. Use PLASTIC MODEL PAINT for any paint trim. Scale details such as machine guns, exhaust pipes, cockpit coaming, etc. are made from scrap if desired. (Plastic soda straws make great exhaust pipes, and they're light). Apply decals at locations shown. Scale control surface outlines may be drawn carefully with India ink or thin strips of black tape. Your Peanut Scale S. E. 5a is now finished. Be sure it balances at arrow shown on side view, and that you read flight instructions on opposite side before flying. We would like your comments and suggestions on this kit and possible new kit selections. Write to: Sterling Models, Inc., 3620 "G" St., Phila., Pa. 19134, U.S.A. GOOD LUCK AND GOOD FLYING!

TISSUE COVERING

Frame is covered tissue dry. Use clear dope to attach tissue. Apply a light coat of dope to the outside edges of the area to be covered and allow to dry. Cut tissue to shape required, about 1/4" oversize all around. Apply a second coat of dope to the frame, then put the tissue in place smoothing into frame and working out any wrinkles. When dry, excess tissue is trimmed off with sharp blade. If any wrinkles develop, cut out wrinkled area (bounded by nearest framework) and recover section. Entire model is covered with green tissue. COVER TOP OF WINGS using 1 piece for each. Cover top of wings in separate pieces; center section and outer wing panels. If any problem of wrinkles is encountered on tips or center section, use separate pieces of tissue. COVER STAB AND RUDDER with single piece of tissue for each side. COVER SIDES & BOTTOM OF FUSELAGE using one piece

of tissue for each. Top of fuselage is covered from front to rear of cockpit with one piece then rear is covered with two pieces joining over center stringer. Using a fine spray (such as from a perfume atomizer) spray tissue lightly with water to shrink. BE SURE TOP AND BOTTOM ARE SPRAYED AT THE SAME TIME! Set aside to dry on end, so that it is surrounded by air, permitting equal drying. This should prevent warps. Apply 3 coats of clear dope thinned with equal parts of thinner (50/50). Apply to top and bottom of surfaces AT SAME TIME and allow to dry in same manner. Check that wings and tail surfaces are free of warps before assembling. Warps can be removed by holding over steam (from boiling kettle) and twisting gently in opposite direction. Hold until cool and check again. Model is now ready to be assembled as described in Final Assembly.

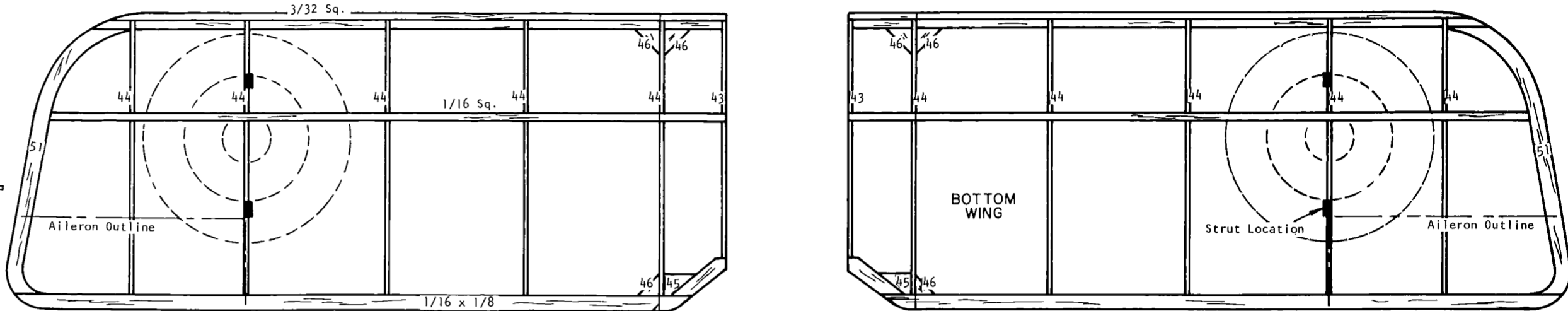
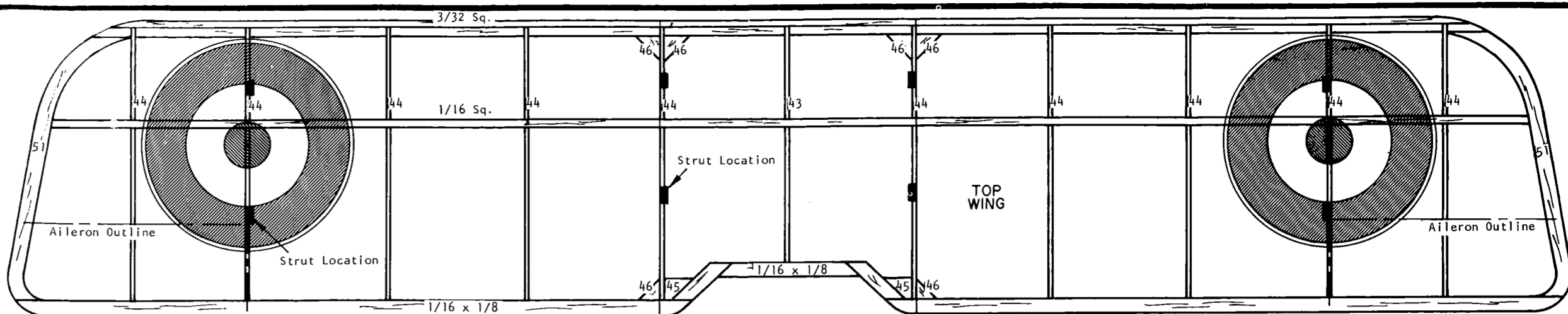

WING ASSEMBLY

STEP 1

Cut 1/16" x 1/8" trailing edge pieces to shape and pin to plan, then cement tips #51 to trailing edge. Cement all ribs vertically in place in numerical order shown. Top wing has a single #43 in center as shown. Bottom wing is built in same manner, however two #43's are used as shown by dotted lines in sketch. Cut 3/32" square leading edge to length and cement to front of ribs and tips. See that ribs remain vertical and in line with ribs on drawing. 1/16" square spars are now added to notches in top of ribs as shown. All cemented in place except at inner rib #44, which must be free to move when installing dihedral in next step. Spars are cracked at tip rib to angle down fitting flush within tip. Cement gussets #45's and #46's in place as shown and allow wing to dry thoroughly.

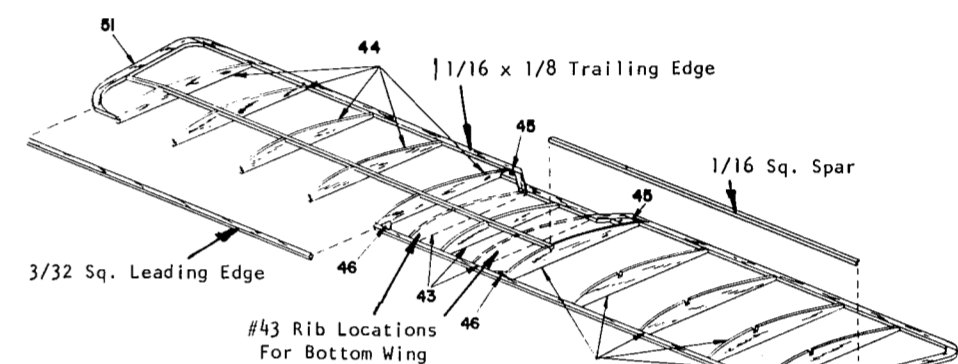

STEP 2

Using your sharp razor blade, cut completely through leading and trailing edges on outside of inner ribs #44, thus separating outer panels from center section. Keeping center section pinned down, remove panels from flat surface and cement outer panels back in place, raising tips 9/16" as shown for dihedral. Remaining wing gussets #46's are now immediately cemented in place and assembly permitted to dry THOROUGHLY. When dry, sand frame smooth rounding trailing edge and tips into leading edge. Build bottom wing in same manner locating two #43's over full-size plan as shown.

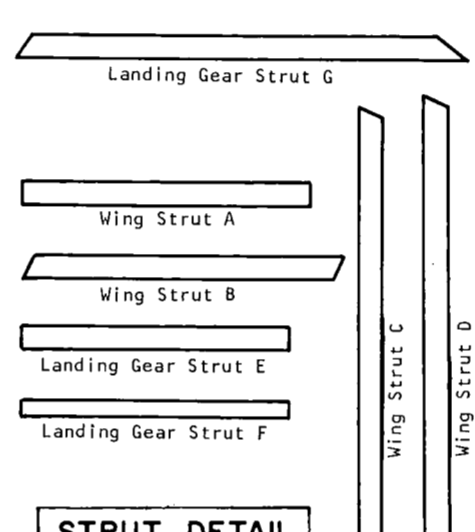
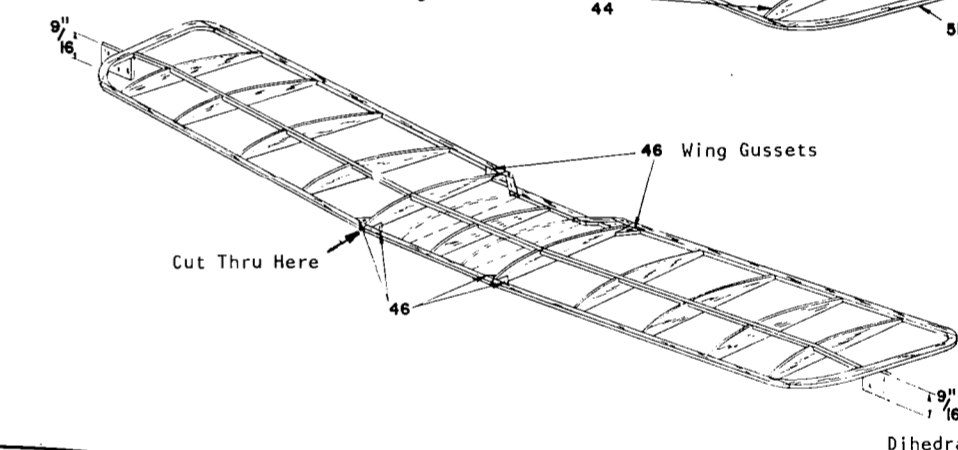

STRUT DETAIL

Cut all struts from 1/16" x 1/8" strips using full-size patterns. Sand smooth, rounding corners. Make two of each.

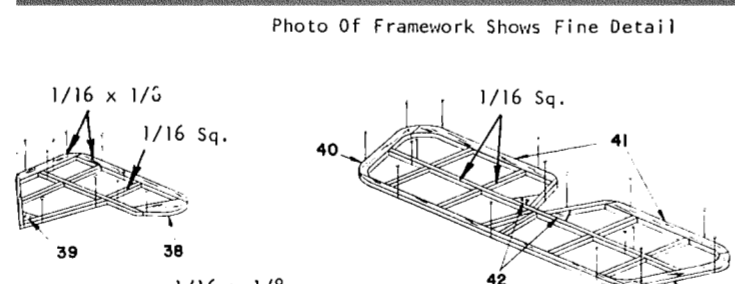
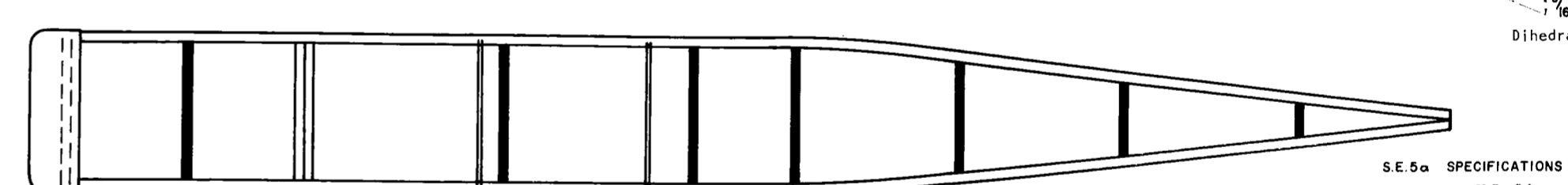

TAIL ASSEMBLY

Pin and cement number parts together over plan. Complete assembly by adding 1/16" square and 1/16 x 1/8 strips cut to fit, and cement in place. Allow frames to dry thoroughly before removing from flat surface then sand smooth, rounding edges. Cover as described in Covering Note.

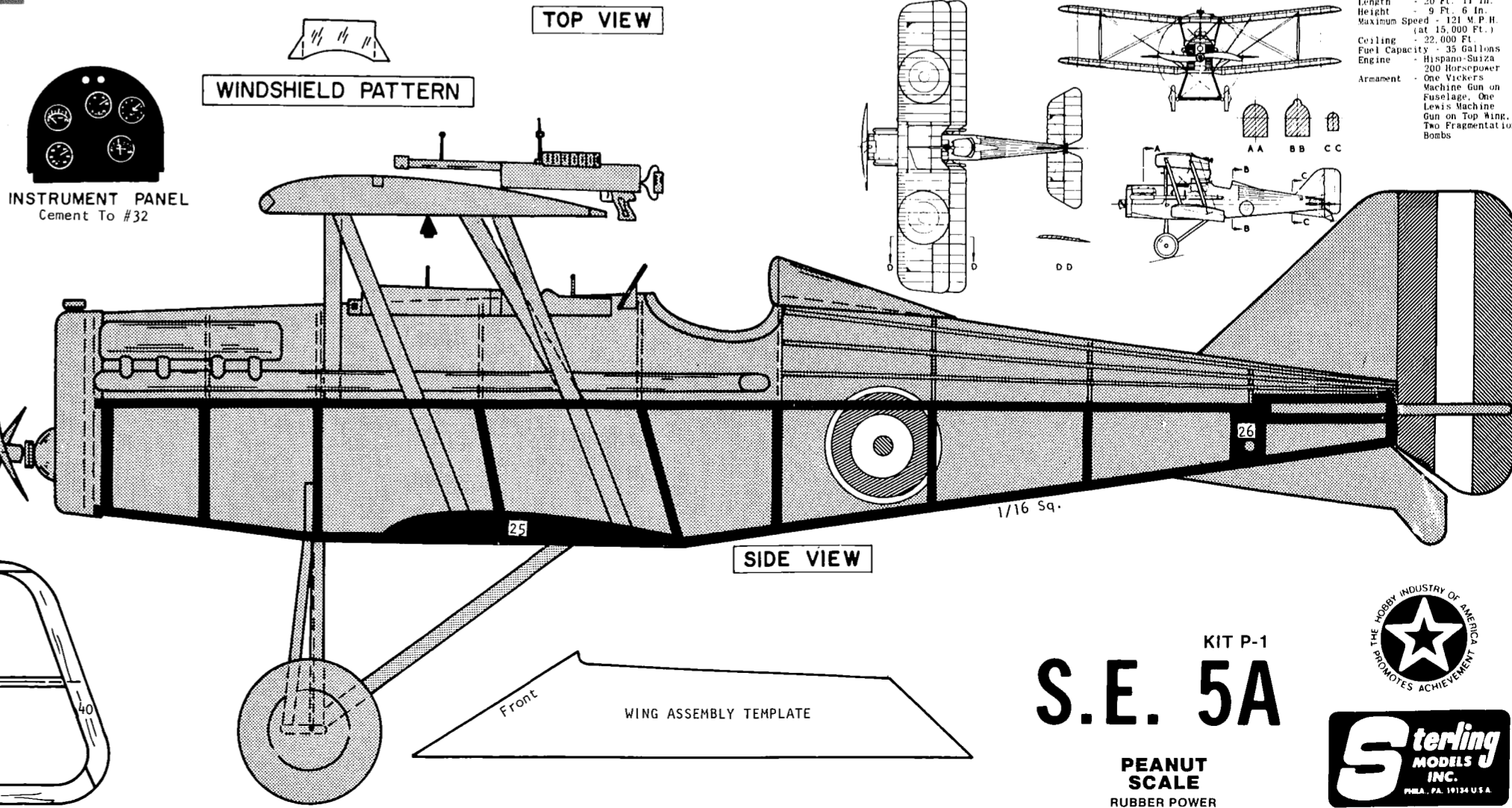
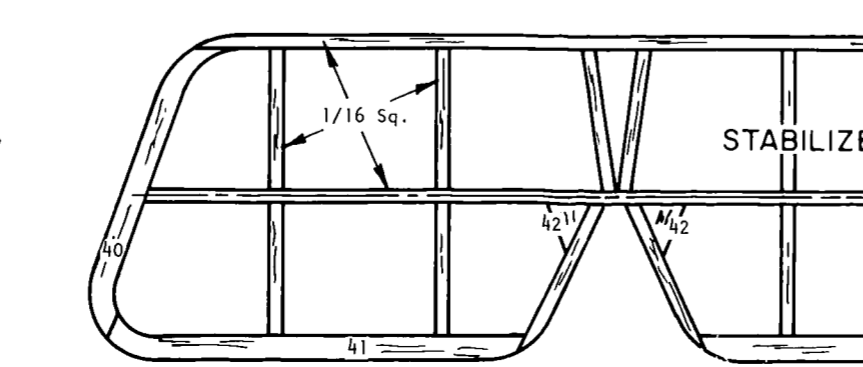
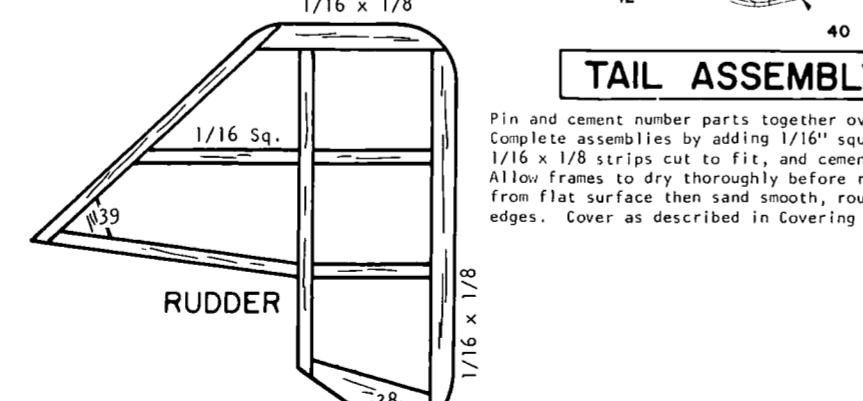

S.E. 5a SPECIFICATIONS

- Wing Span - 26 Ft. 11 In.
- Length - 20 Ft. 11 In.
- Height - 9 Ft. 6 In.
- Maximum Speed - 121 M.P.H.
- Cruising - 100 M.P.H.
- Alt. 15,000 Ft.
- Engine - 25-hp. Oerlikon
- 200 Horsepower
- One Victrola
- Machine Gun on
- Lewis Machine
- Gun on Top Wing.
- Two Fragmentation
- Bombs

KIT P-1
S.E. 5A
 PEANUT SCALE
 RUBBER POWER

Sterling
 MODELS
 INC.
 PHILA. PA. 19114 U.S.A.