

FUSELAGE ASSEMBLY

STEP 1

Remove any creases in plan. Tape down to building board, and cover with Saran Wrap to prevent frame from sticking to plan. Printed parts may all be cut out before construction is started. Using wire provided, bend landing gear to shape of full-size pattern. Gear is now cemented between bulkheads #4, as shown on dotted location on #4. Solid black lines on full-size side view is the fuselage side frame. Cut 1/16" square strips carefully to length, pin & cement in place. Add part #1. Allow side frame to dry before removing from board, then build another identical side frame.

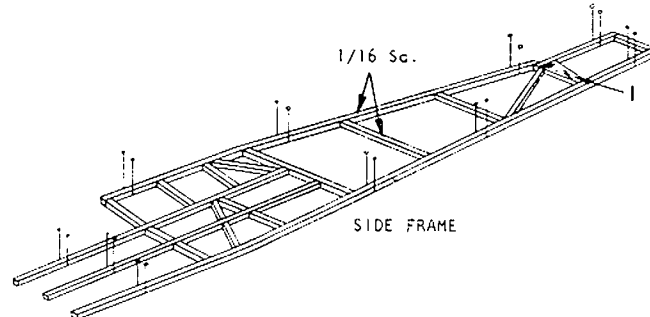

STEP 2

Assemble fuselage sides by cementing them together at rear. Be certain ends are perfectly flush with each other, then cement landing gear bulkhead #4 in place as shown. Cut the 1/16 sq. cross-member to length and cement it in place at front of cabin as shown. Allow to dry.

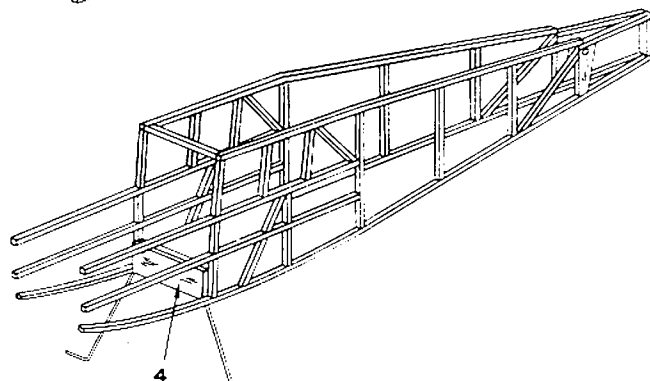

STEP 3

Cement front bulkheads #2 and #3 in place as shown, then cut cross-members to length shown in solid lines on top view. Cement in place working from front to rear, holding sides together with tape where necessary. Where sharp bends occur, strip may be cracked or nicked with razor to remove strain. Both sides must be treated the same in order to avoid distortion. Check assembly with top view to be certain fuselage is aligned properly. Also check from front and rear to be sure fuselage is square and not distorted. When dry, cut up cowl stringer using pattern provided. Cement #5 to fuselage leaning forward so that top center stringer sets up proper angle of #5 as shown. When dry, add #18 bottom cowl stringer. Clip head off straight pin, bend tail gear to shape shown on pattern. Tail gear is shown on sketch for clarity only. It is installed after fuselage is covered.

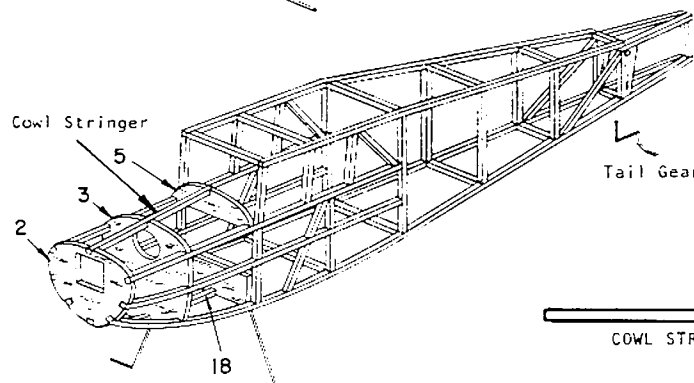

INTRODUCTORY NOTE

Peanut Scale is fun to build and fun to fly. Building, however, does require careful attention when cutting out the parts and assembly. Plans should be followed closely to insure a well built and good flying model. Model is built directly on plan. Pins are used to hold the parts in place while frame is drying. Wherever possible, pins should not be pushed through the frame but angled around it to keep the part in place. Pinholes may weaken the structure. We recommend that model be built with "white glue" such as Tite Bond or Elmer's Glue, used sparingly. Excess glue only adds weight, not strength. Model airplane cement is used VERY SPARINGLY on plastic parts. Light coats must be used so that plastic is not distorted. Follow covering instructions closely, so that light structure does not warp. Assemble the following material and tools, which are not included in kit: FLAT building board, pliers, straight pins, hammer, tweezers, single edge razor blade, Saran Wrap (or similar), glue, dope (paint), thinner, paint brush, fine sandpaper, masking tape.

STEP 1

Assemble both wing tips by cementing #13 & #14 together over plan. Remove when dry. Cut 1/16" x 1/8" trailing edge to shape and pin to plan, then cement assembled tips to trailing edge. Cement all ribs vertically in place in numerical order shown. Cut 3/32" square leading edge to length and cement to front of ribs and tips. See that ribs remain vertical and in line with ribs on drawing. Cut 1/16 sq. strut support to length and cement in place between leading and trailing edges. 1/16" square spars are now added to notches in top of ribs as shown. All cemented in place except at center rib #15, which must be free to move when installing dihedral in next step. Spars are cracked at rib #16 to angle down fitting flush with tip. Allow wing frame to dry thoroughly.

STEP 2

Using your sharp razor blade, cut completely through leading and trailing edges on outside of center ribs #15, thus separating outer panels from center section. Keeping center section pinned down, remove panels from flat surface and cement outer panels back in place, raising tips 5/8" as shown for dihedral. Wing gussets #17's are now immediately cemented in place and assembly permitted to dry THOROUGHLY. When dry, sand frame smooth rounding trailing edge and tips into leading edge.

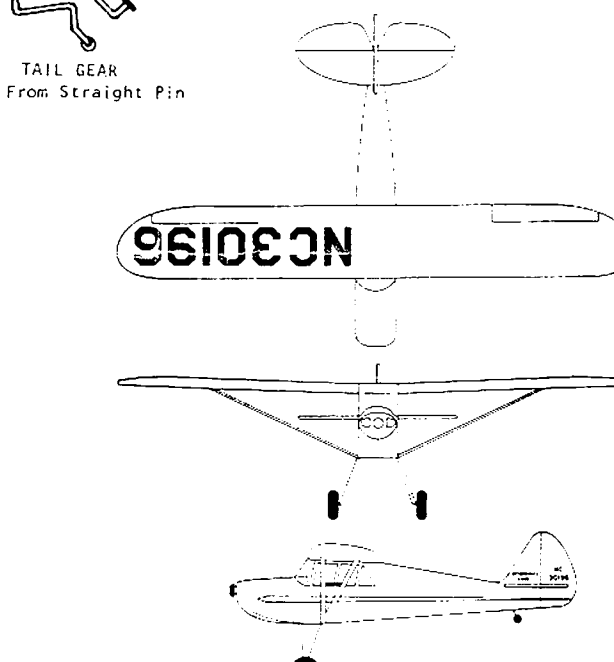
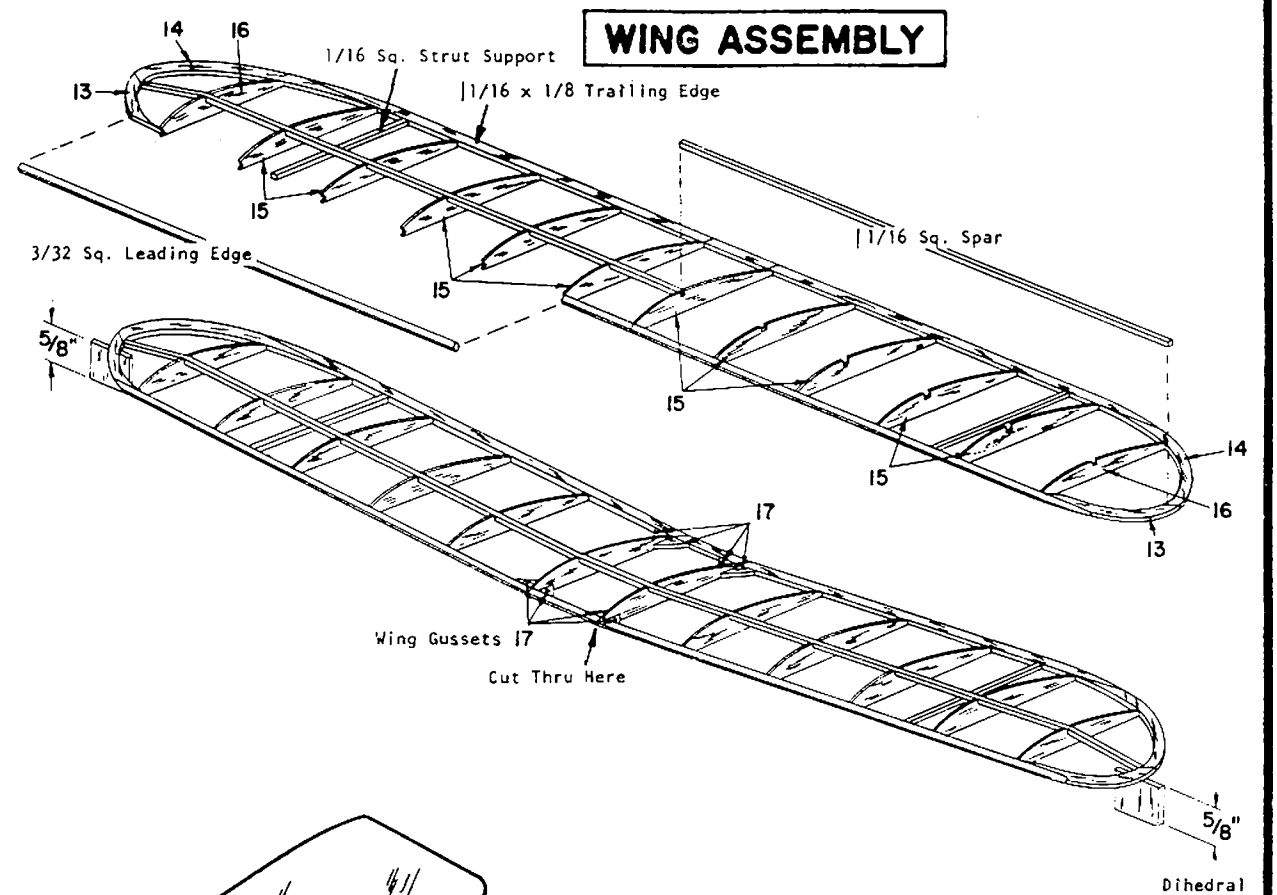

SCALE DETAILS AND SPECIFICATIONS

Wingspan 35" 6" Area 173.8 Sq. Ft.
Length 24" 0" Height 7" 0"
Engine: 65 h.p. Continental
Maximum Speed 109 mph Average Speed 100 mph

TISSUE COVERING

Frame is covered tissue dry. Use clear dope to attach tissue. Apply a light coat of dope to the outside edges of the area to be covered and allow to dry. Cut tissue to shape required, about 1/4" oversize all around. Apply a second coat of dope to the frame, then put the tissue in place smoothing into frame and working out any wrinkles. When dry, excess tissue is trimmed off with sharp blade. If any wrinkles develop, cut out wrinkled area (bounded by nearest framework) and recover section. Fuselage and rudder are covered with red tissue, wing and stabilizer with yellow tissue. COVER BOTTOM OUTER PANELS OF WING using 1 piece for each panel; cover top of wing in 3 pieces; center section and outer wing panels. If any problem of wrinkles is encountered on tips, use separate pieces of tissue. COVER STAB AND RUDDER with single piece of tissue for each side. COVER TOP & SIDES OF FUSELAGE using one piece of tissue for each. Top of cowl is covered with stiff paper (not supplied) such as the plan paper then: Top & Bottom section of cowl is covered with 1 piece of tissue each, as is the bottom of the fuselage. Using a fine spray (such as from a perfume atomizer) spray tissue lightly with water to shrink. BE SURE TOP AND BOTTOM ARE SPRAYED AT THE SAME TIME! Set aside to dry on end, so that it is surrounded by air permitting equal drying. This should prevent warps. Apply 3 coats of clear dope thinned with equal parts of thinner (50/50). Apply to top and bottom of surfaces AT SAME TIME and allow to dry in same manner. Check that wing and tail surfaces are free of warps before assembling. Warps can be removed by holding over steam (from boiling kettle) and twisting gently in opposite direction. Hold until cool and check again. Model is now ready to be assembled as described in Final Assembly.

WINDSHIELD PATTERN

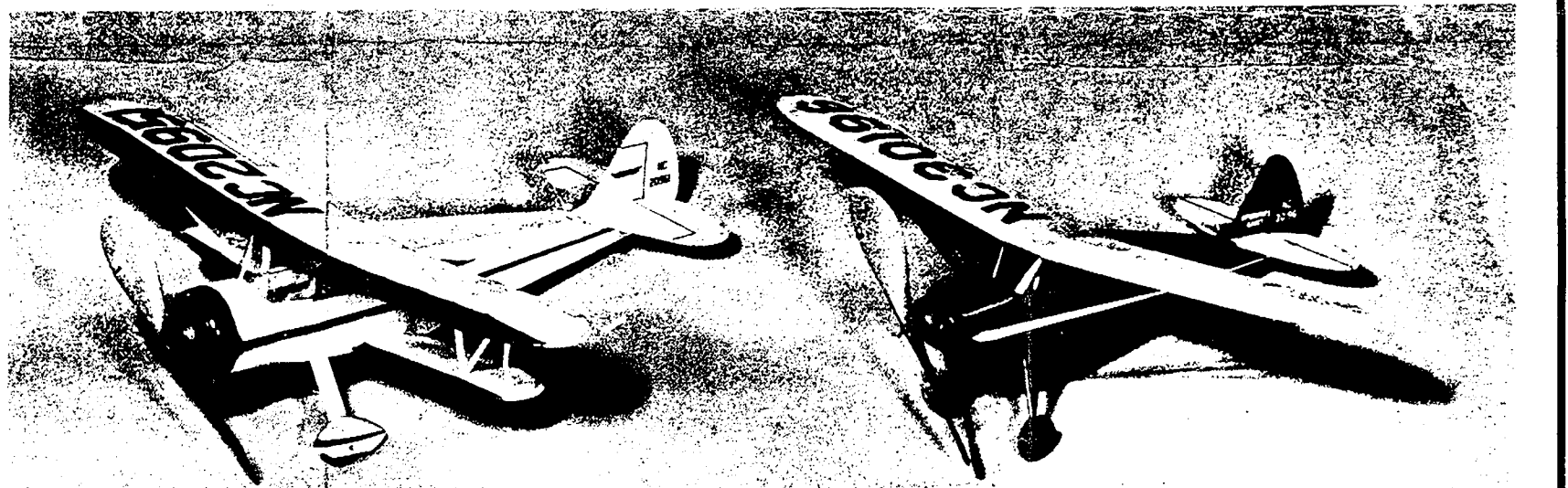
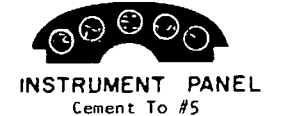

They Fly As Great As They Look

FINAL ASSEMBLY

Although sketch shows model uncovered, all components are actually covered (as described in Covering Note) before assembling model. Cement stabilizer and rudder to rear of fuselage, being certain stab is horizontal, rudder vertical. Cement wing to top of fuselage, trailing edge located at rear of cabin, as shown on side view. Check wing and tail alignment from front and top. Cement wing struts in place, location shown on side view and wing plan; #19 landing gear struts are sanded smooth, rounding edges then cemented to wire landing gear, shown on side view and sketch. Top may be cut off at angle (shown in sketch) to permit flexing. Slip wheels on axles and secure with a drop of cement. Cement tail gear in place and slip tailwheel #22 on axle. Secure with drop of cement. Place #21 into corresponding cut-out in #2, trimming if necessary for snug fit. Apply a coat of cement to front of #21 ONLY then put #20 in place, aligning with #2, pressing #21 against #20. When cement is dry remove assembled #20 & #21. Cut cowl on flat surface, #21 down, push rear of cowl over assembly so that #21 is flush with rear of

cowl and #20 is recessed 1/16" within cowl. Cement in place with VERY LIGHT COATS of wood model airplane cement to prevent distortion. Using celluloid provided, cut windshield to pattern shape and cement in place. Slip nose button on propeller shaft, followed by the two washers. Insert shaft through rear of prop and make a 90° bend in end of shaft to engage prop. Install rubber loop by dropping thru fuselage. Push dowel thru hole in #1, thru rubber loop and into hole in opposite #1, thus capturing rubber. Bend wire hook out of paper clip and pull rubber loop out of fuselage and engage in propeller shaft hook. Box wrap shows color. Use PLASTIC MODEL PAINT for any paint trim. Apply decals at locations shown. Scale control surface outlines may be drawn carefully with India ink or thin strips of black tape. Your Peanut Scale Interstate Cadet is now finished. Be sure it balances at arrow shown on side view and that you read flight instructions before flying. We would like your comments and suggestions on this kit and possible new kit selections. Write to: Sterling Models, Inc., 3620 10th St., Phila., Pa. 19134, U.S.A. GOOD LUCK AND GOOD FLYING.

FLIGHT INSTRUCTIONS

DO NOT ATTEMPT TO FLY MODEL UNTIL BALANCE (AT ARROW SHOWN ON SIDE VIEW) HAS BEEN ACHIEVED! ADD WEIGHT TO FRONT OR BACK IF NECESSARY. Check wing and tail. If warps have developed, remove using steam method described in Covering Note. Model is now ready. Pick a calm day for test-flying. Wind propeller clockwise, release propeller, then gently launch into any prevailing wind, slightly nose down at a point on the ground about 50 ft. ahead of you. If model noses up and then falls off and stalls (AFTER MODEL WAS BALANCED), bend elevators down slightly, using hot breath in same manner as steam. If model dives, bend elevators up. If model veers too much to one side, bend rudder to opposite side. If model glides well but stalls, dives, or turns under power; cement 1/16" balsa shim to front

bulkhead which will angle cowl to opposite direction, (down on side thrust). Increase or decrease shim thickness as necessary. Take-offs require more power and therefore more turns in rubber motor. For longer flights and competition, it is recommended that model lubricant (available at most hobby shops) be used. Apply lubricant sparingly. Use winder, (Sterling Models Rubber Winder is highly recommended, it is available at your Dealer at a very reasonable price.) To store winds in motor, stretch rubber out 3 to 5 times original length, then proceed to wind, moving slowly back to model. Feel rubber from time to time to be certain that it does not get so taut that it breaks. Upon reaching nose, motor should be completely wound. GOOD LUCK AND GOOD FLYING.

WING STRUT DETAIL

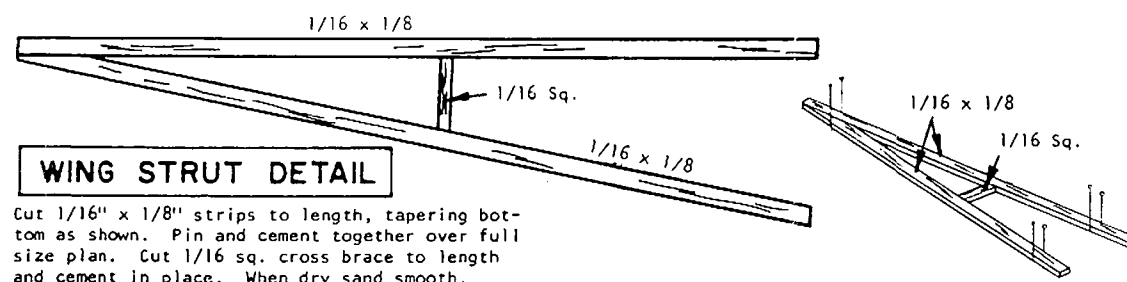

Cut 1/16" x 1/8" strips to length, tapering bottom as shown. Pin and cement together over full size plan. Cut 1/16 sq. cross brace to length and cement in place. When dry sand smooth, rounding corners. Make two assemblies.

TAIL ASSEMBLY

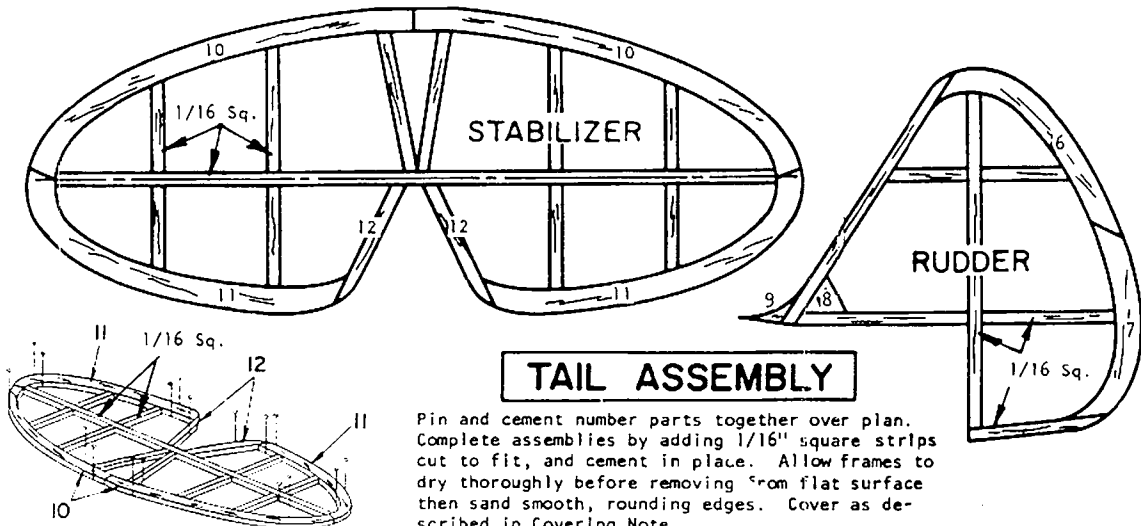

Pin and cement number parts together over plan. Complete assemblies by adding 1/16" square strips cut to fit, and cement in place. Allow frames to dry thoroughly before removing from flat surface then sand smooth, rounding edges. Cover as described in Covering Note.

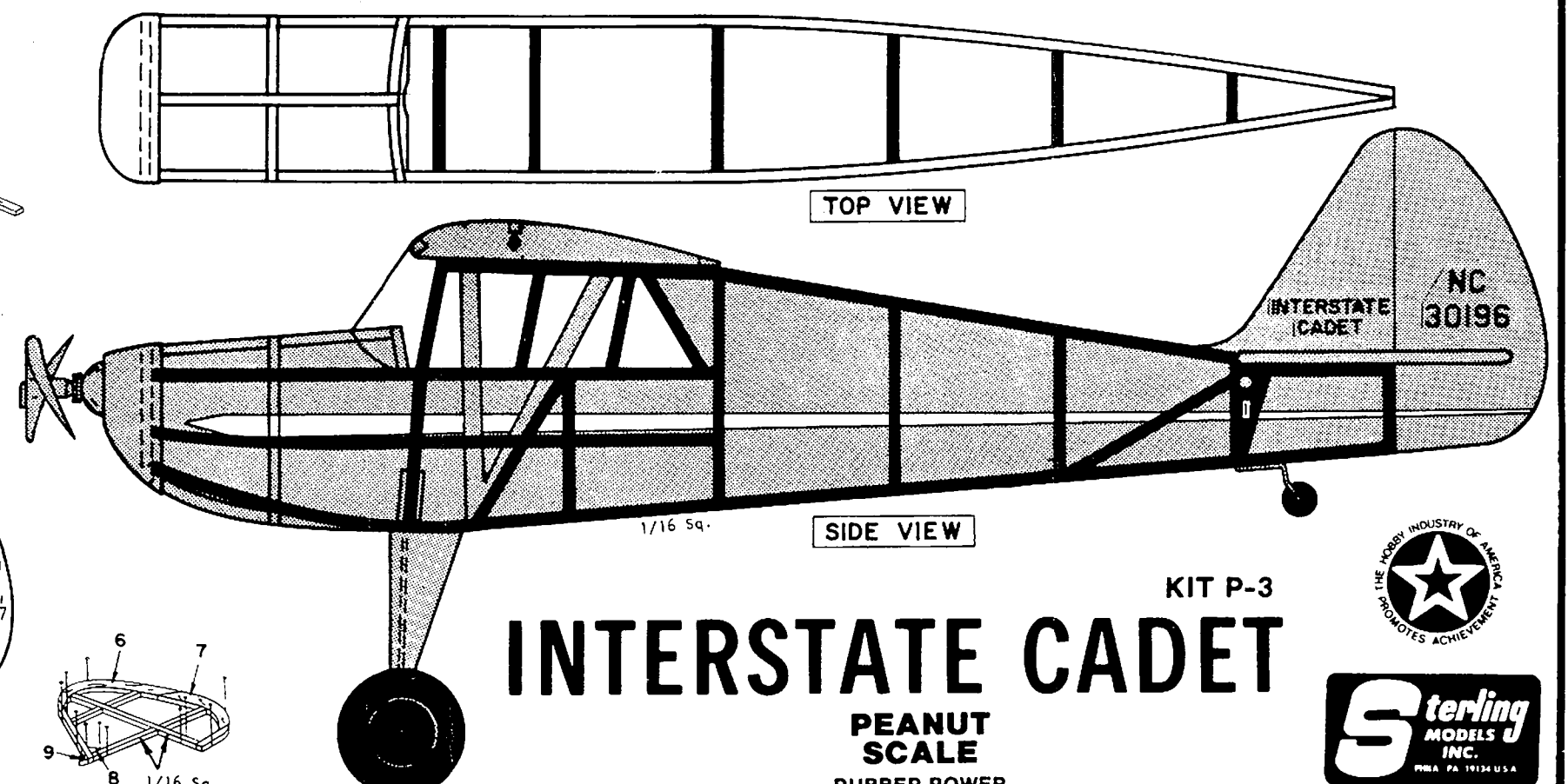

INTERSTATE CADET

PEANUT SCALE RUBBER POWER

