

STEP 1

Select a flat building surface to insure a non-warped wing. Sketch shows right wing panel. Pin 1/4 sq. x 29 bottom spar directly over plan, then cement ribs in place by the number shown. Followed by top 1/4 sq. x 29 rear bottom skin covering into notches. Trailing edge is cemented to rear of ribs. Leading edge is now cemented to front of ribs. Cement 1/4 x 3/4 x 22-1/2 center spar into notches between top and bottom spars, until it rest against rib JAC. Cement ribs into notches in ribs 31 to 37 as shown.

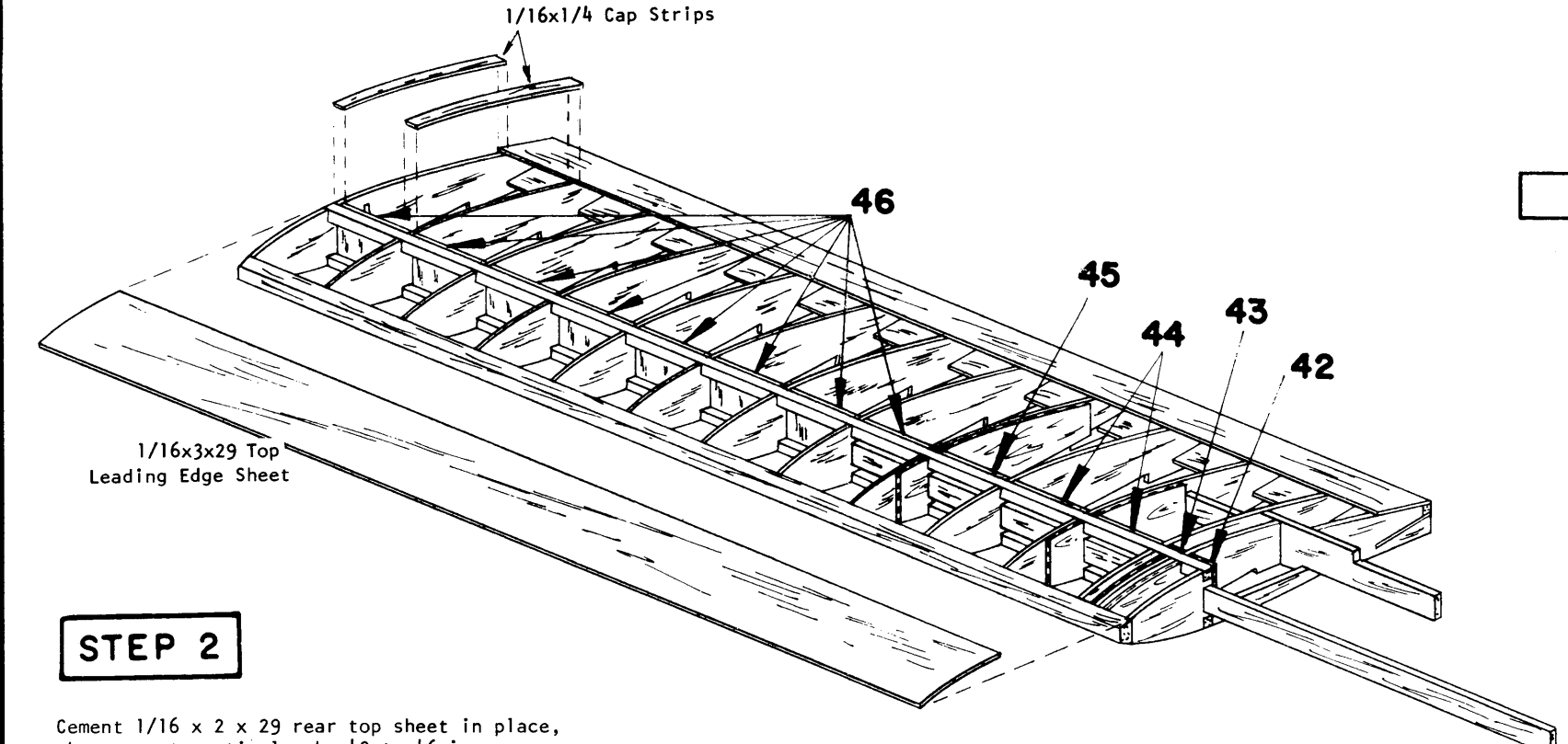

STEP 2

Cement 1/16 x 3 x 29 rear top sheet in place, then cement vertical web 42 to 46 in place. Followed by 1/16 x 3 x 29 leading edge sheet. Rear of leading edge sheet comes in center of spar to allow gluing surface for 1/16 x 1/4 cap strips (taken from strip sheet) which are cut to length and cemented to top of ribs between front and rear sheeting. ALL CEMENT JOINTS MUST BE THOROUGHLY DRY BEFORE WING IS REMOVED FROM FLAT SURFACE TO INSURE A WARP FREE WING.

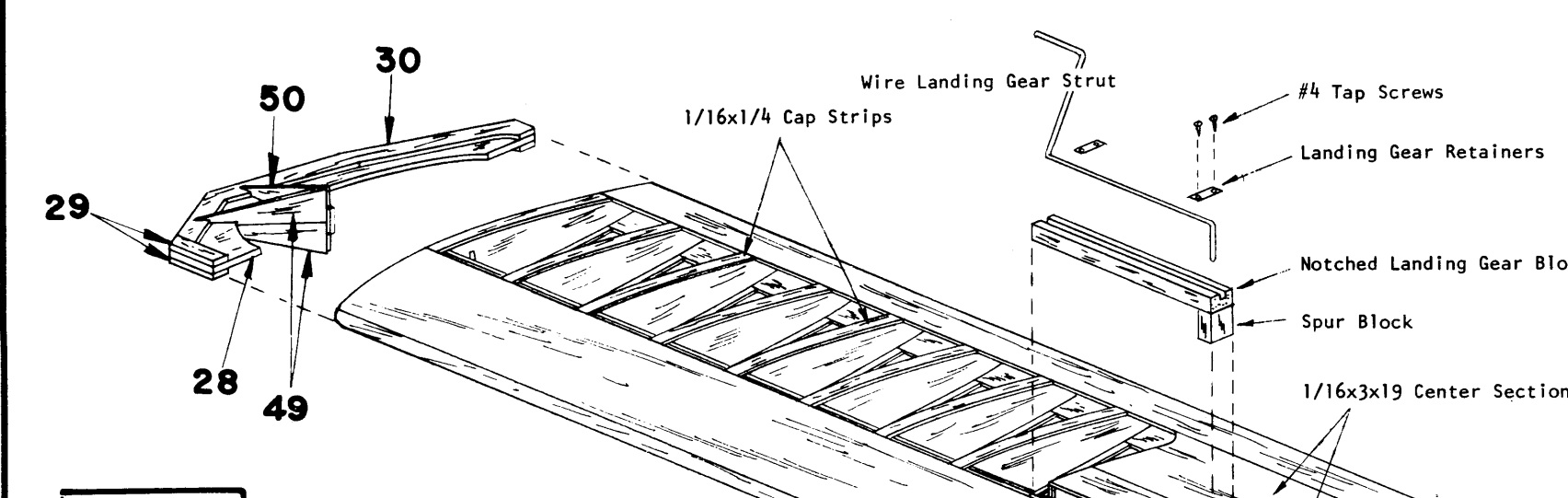

STEP 3

Cement bottom leading edge sheet and cap strips in place. Securely cement landing gear spur block into corner formed by spars and rib 36/37. Notched landing gear block is now securely cemented into notches across ribs. Be certain hole in landing gear block lines up with slot in spur block. Check by inserting landing gear spur. Use several coats of cement. Center section is now covered with 1/16 x 3 x 19 sheet as shown in sketch and full size drawing. Notching out for landing gear block which is flush with covering. Landing gear strut installation is shown for clarity and will be referred back to this sketch when this installation is made in final assembly step. Assemble wing tip by cementing 28 and 30 to top and size pins to form triple layer. Unit is now cemented against tip, then 49's and 50's are added to top and bottom as shown, locating so that they are flush with rib. Opposite wing panel is constructed in the same manner except 47 is obviously omitted.

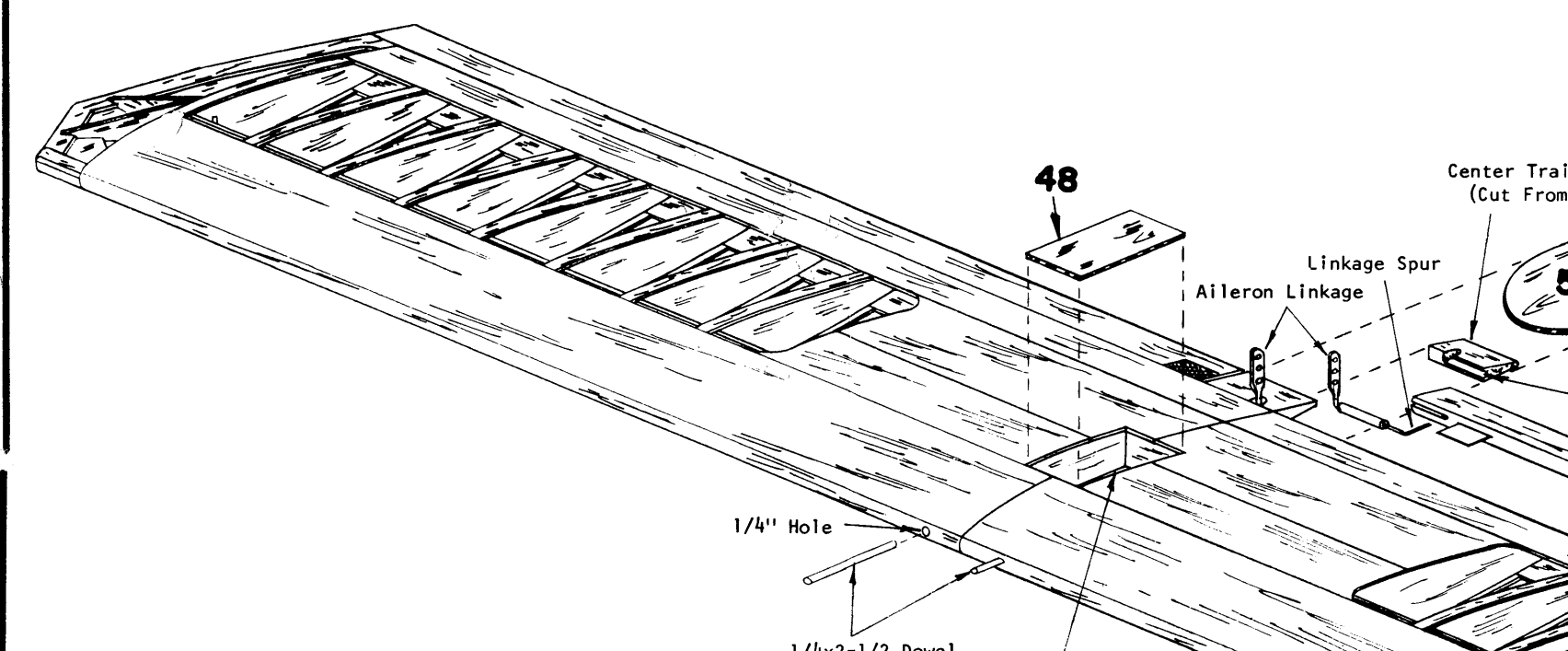

STEP 4

Rib sheet covering, spars, etc. Flush with center ribs. Spread cement generously over ribs, then join panels inserting spar and 47 into left panel. Use pins to hold panels tightly together around top and bottom to insure good contact, then cement 48 in place to complete aileron servo box. Also assemble wing to dry thoroughly, then cover center section with 1/16 x 3 x 19 sheet, trailing out for aileron servo box as shown. Remove all pins and sand entire wing smooth. Round off and blend tip into wing leading tip points sharp, as shown on full size drawing to maintain distinctive Lancer 54-55 shape. Drill 1/4" hole through center of leading edge as shown, then insert and cement 1/4" length of dowel in front of which is rounded as shown. Cut a 1/4" length OFF EDGE aileron for center trailing edge sections, then notch out the front so that it fits completely over nylon sleeve bearing on aileron linkage as shown. Trailing edges are then cemented securely in place capturing aileron linkage. Plywood bottom plate 51 is now cemented to bottom of wing in position shown on full size plan, so that rear is flush with rear of trailing edge sections. Use cement generously on this installation. When dry, check that aileron linkage moves freely. Round off front of aileron. Locate and drill hole for linkage spur, and install aileron on wing with polypropylene hinges as shown and described in sketch and detail note. Cut a length of cloth tape provided and insert through space between aileron and wing, and cement securely around aileron to strengthen linkage spur area. Cloth tape is now wrapped completely around top and bottom of center joint using cement generously. Work cement into cloth and when dry apply a second coat of cement which is then sanded smooth.

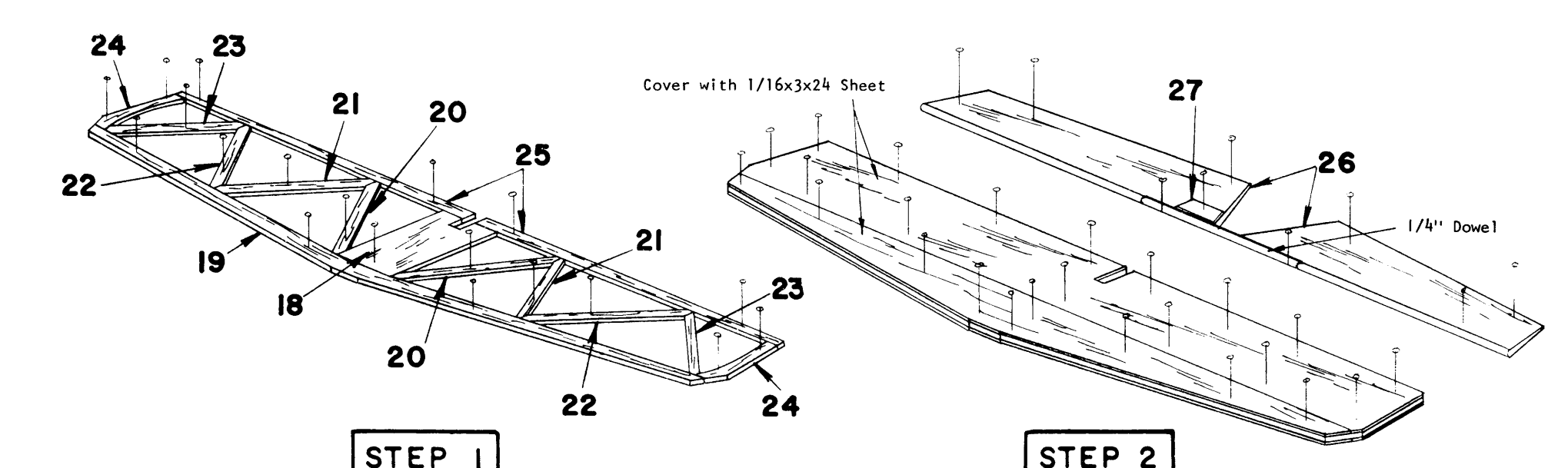
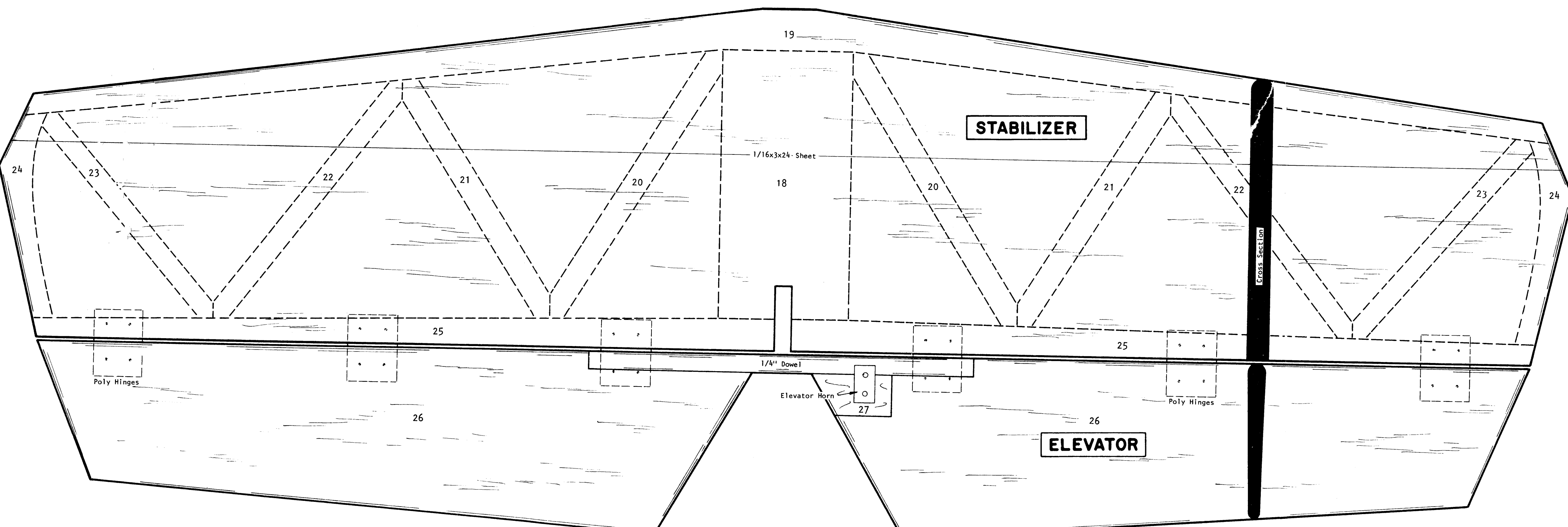
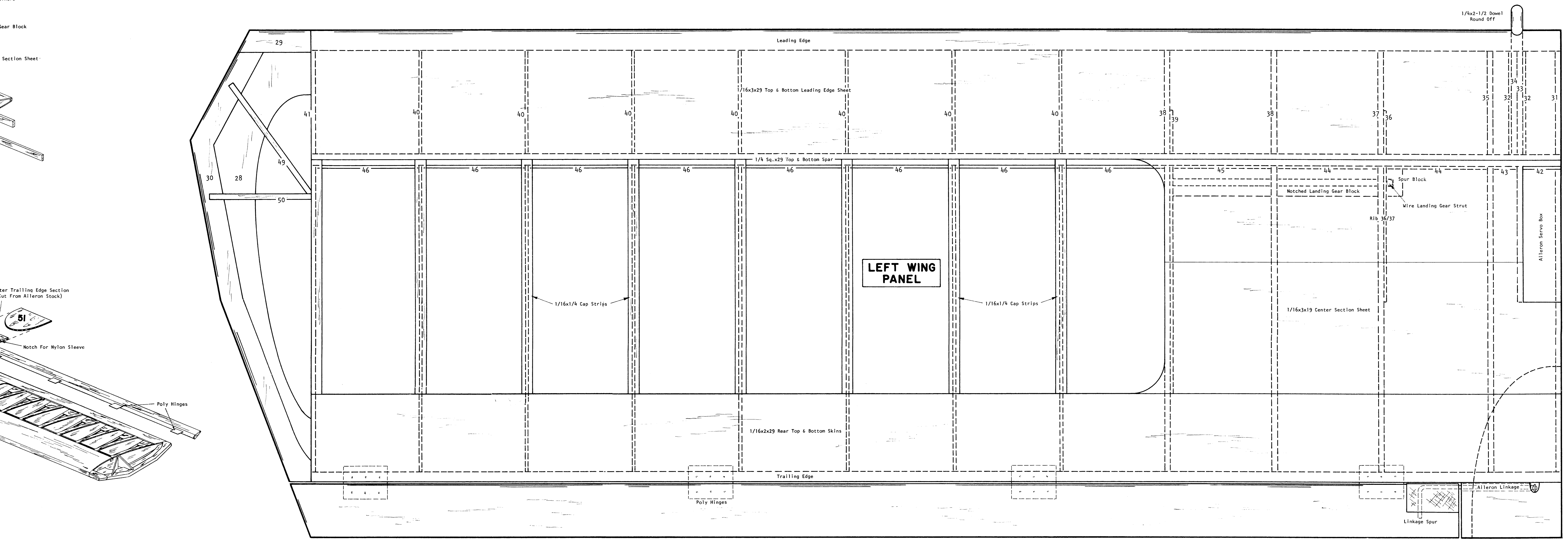
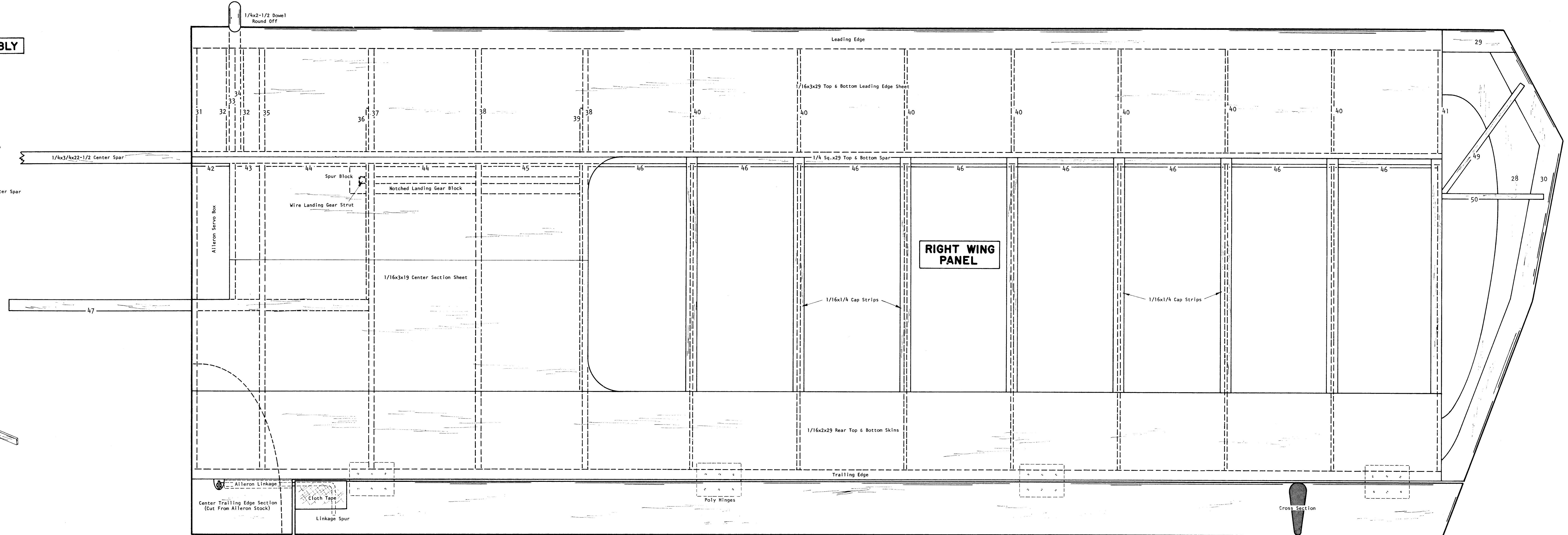

STEP 1

STEP 2

STABILIZER ASSEMBLY

Stabilizer is built directly over plan using parts 18 to 25 as shown in sketch. Allow to dry thoroughly before removing pins, then cover top and bottom with 1/16 x 3 x 24 sheet, joining as shown. Frame should be aligned down to flat surface while sheet covering is drying, to prevent warping. Pin 26 in place then securely cement 1/4" dowel into notches and allow to dry thoroughly. When dry, remove and add two additional coats of cement, making certain sections show alignment with each other. Sand stabilizer smooth, rounding edges and tapering elevators to cross section shown. When rounding tips, be sure to keep points sharp to maintain distinctive Lancer 54-55 shape. Join elevators to stab with special poly hinges (see detail) Elevator horn shown in full size drawing is approximate location. This may vary with the installation of your own radio gear. If not a wire desired, plywood reinforcement plates 27 may be recessed into elevator to provide a stronger mounting surface. This, however, is not really necessary with the type of horns provided in the kit.

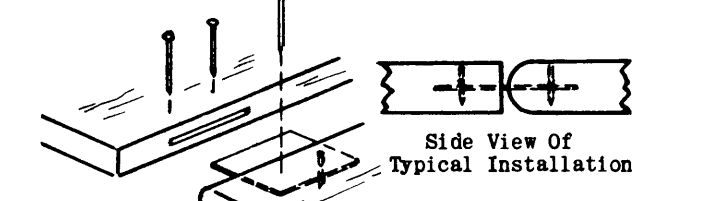

POLY HINGE INSTALLATION

The use of Polypropylene as a hinge is now wide spread commercially. Industrially because this miraculous plastic actually gets stronger with each bend, and it is so flexible, that hinged surfaces move freely & easily. Believe it or not this Poly Hinge has a one-million-fold life expectancy. You can test its fantastic strength by trying to tear it on the hinge (reverse) line.

TO INSTALL: Cut strip to desired hinge width (generally about 1/2"). Still surface to be joined as shown (in center of thickness). Epoxy Hinge into slots, (hinge line in center between surfaces) leaving enough space for free movement. Secure hinge by pushing straight pins through wood AND HINGE as shown. Pins are clipped flush.

