

WING ASSEMBLY

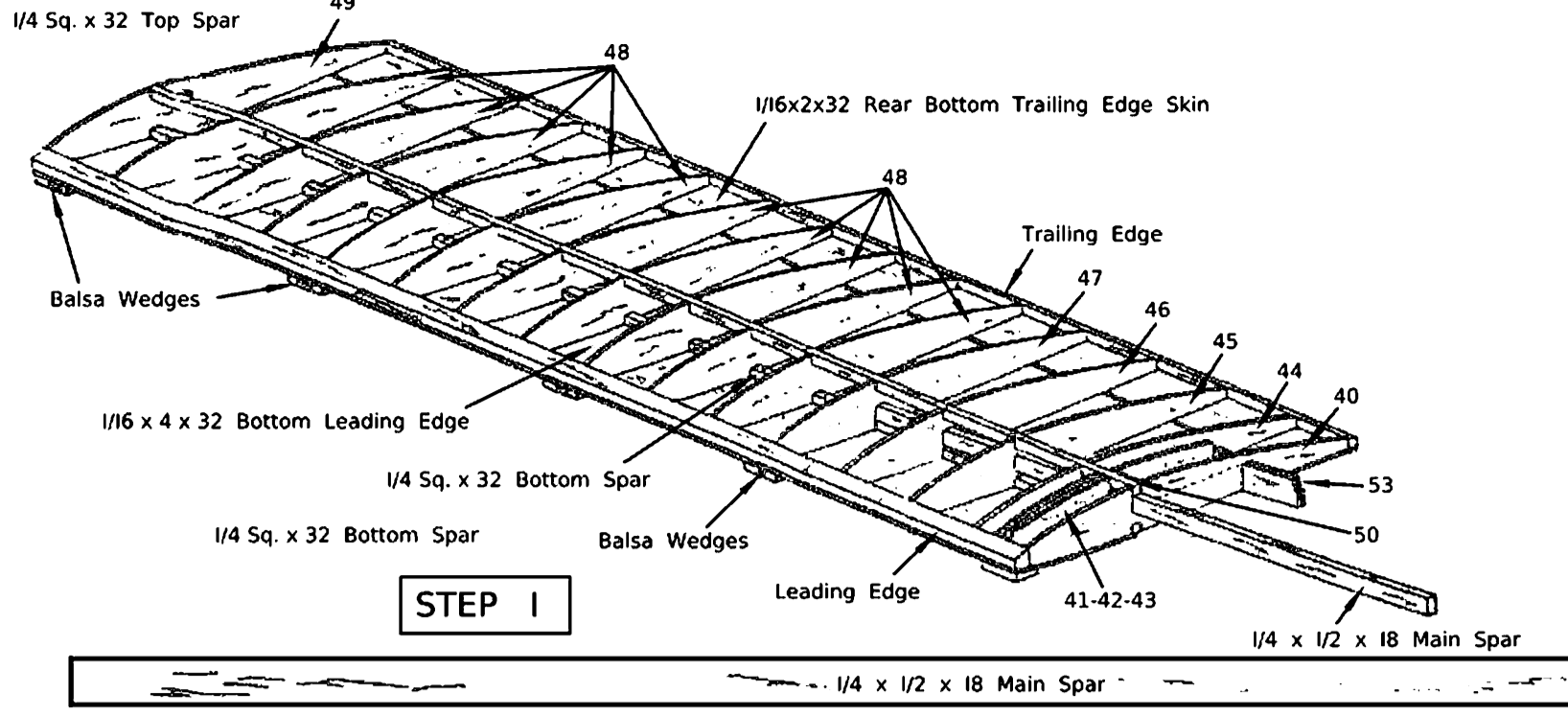

Select a flat building surface, to insure a nonwarped wing. Sketch shows assembly of right wing panel. Wing is built directly over Plan. Pin U6 x 2 x 32 Trailing Edge bottom Skin covering in place over Plan. Pin U6 x 4 x 32 Bottom Leading Edge sheet in place. Cement U4 sq x 32 Bottom Spar to Leading Edge sheet. U6 overhanging rear as shown on full size Wing Plan. Cement all ribs in place by the number shown, followed by top U4 sq Spar. Rib #40 is angled for dihedral. Angle is set by connecting vertical W6 #40 in place between #40 & #41, then #40 is pinned and cemented to it, top leaning in towards #41. Front of sheeting should be cleared of pins and then cemented to bottom of ribs with wedges of scrap Balsa as shown. Cement trailing edge in place to top of sheet covering and against rear of ribs as shown. Tapered top in line with curve of ribs. Leading Edge is cemented in place in same manner. Side U4 x U2 x 18 Main Spar through notches in ribs and securely cement it in place as shown. Insert rear spar #53 across notches in ribs and securely cement in place.

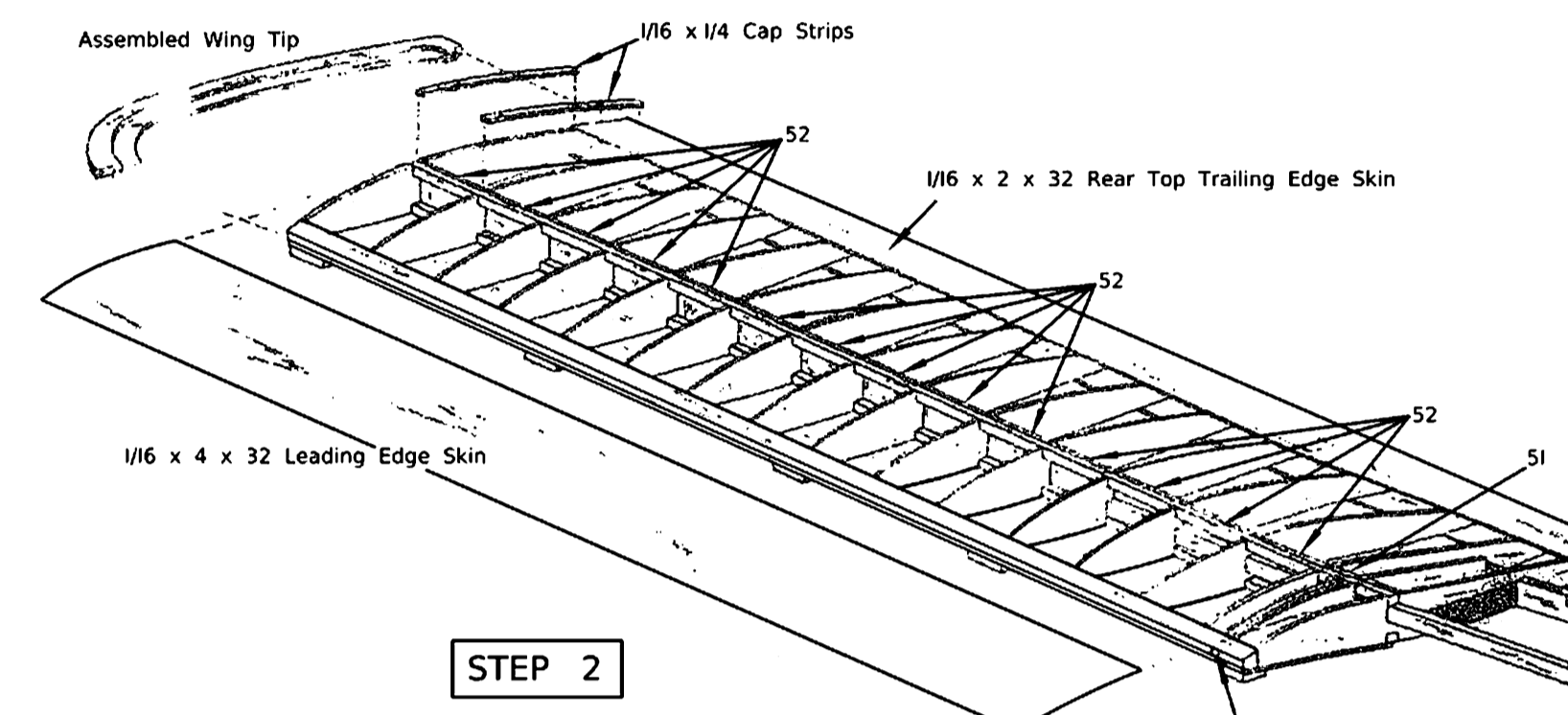

Drill U4" hole for Wing Dowel Pin in Leading Edge. Hole is in center of Leading Edge and directly in line with box formed by assembled Rib #41-42-43 as shown in Step 1 Fuselage Sketch. Cement U6 x 2 x 32 rear top sheet in place. Cement vertical W6's #51 & #52 in place against back of top and bottom Spars as shown. Cement U6 x 2 x 32 Leading Edge sheet in place. Cement assembled Wing Tip against Top Rib #49 and center of top of Rib #48's and #49 between rear and rear sheet covering as shown on Step 1 sketch. When thoroughly dry remove panel from flat surface and cement U6 x U4 Cap Strips to top and bottom of ribs. Opposite Panel is built in same manner, except for Center Spars, which are obviously omitted, and allow to dry thoroughly before removing from flat surface.

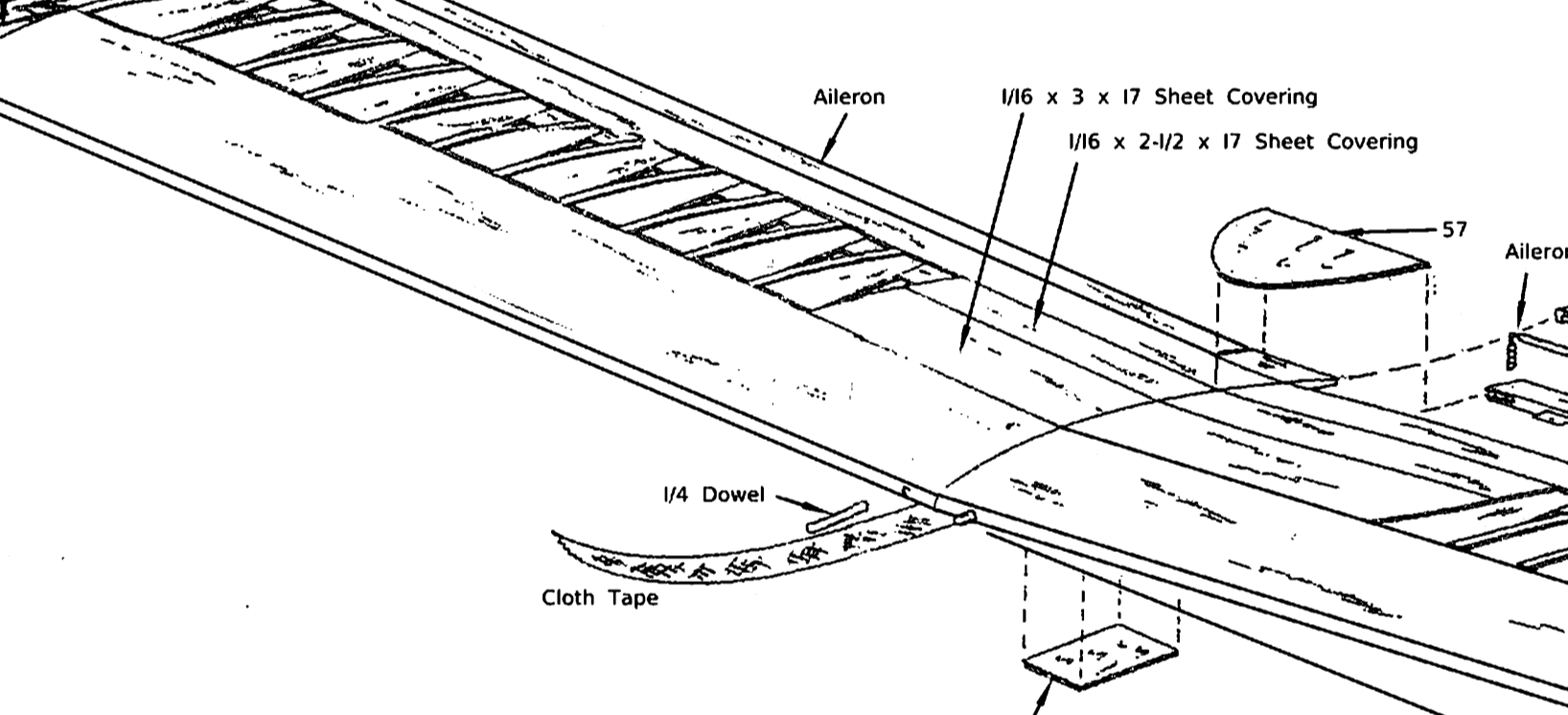

Remove shaded section of Rib's #40 along crease mark (shown in Step 2 sketch) then trim sheet covering, spars, etc. flush with Center Ribs. Spread cement generously over ribs, then join Panels, inserting protruding Spars into notches in left Wing Panel. Use pins to hold Panels tightly together around top and bottom to insure contact and a proper 2 1/2" dihedral as shown. Allow assembled Wing to dry thoroughly, then cover center section with U6 x 3 x 17 and U6 x 2 1/2 x 17 sheet. Trim out bottom between ribs #42, W6's #53 to form serve box. Screw Rib #56 in cemented into area against #42's. Cement Wing Tip Guide's #54 & #55 in place on both Tips as shown. Remove all pins and sand inside wing smooth. Round off and blend Wing Tips smoothly into Leading and Trailing edges. Cut two lengths of U4" Dowel 2" long. Insert and cement them into U4" hole drilled in Leading Edge. Use cement generously and be certain pins seat back in place as shown in full size Wing drawing. Round off front of Dowelling as shown. Cut a 2" length off each piece of tapered Aileron stock, two of which are provided 3 1/2" long. Notch out front of each 2" length, so that they fit completely over right sheet bearing on Aileron Linkage as shown. Sections are then securely cemented in place, capturing Aileron Linkage. Plywood Top Plate #57 is cemented to top of wing in position shown on full size Plan, so that rear is flush. Use Cement generously on entire installation for maximum strength. When dry, check that Aileron Linkage moves freely. Round off front of Aileron stock to cross section shown. Locate and drill hole and notch for Linkage Spur, then install Ailerons with Poly Hinges as shown and described in sketch and detail note. Cloth tape is now wrapped completely around top and bottom of center joint, applying cement generously. Work cement into cloth and when dry, apply a second coat of cement, which is then sanded smooth.

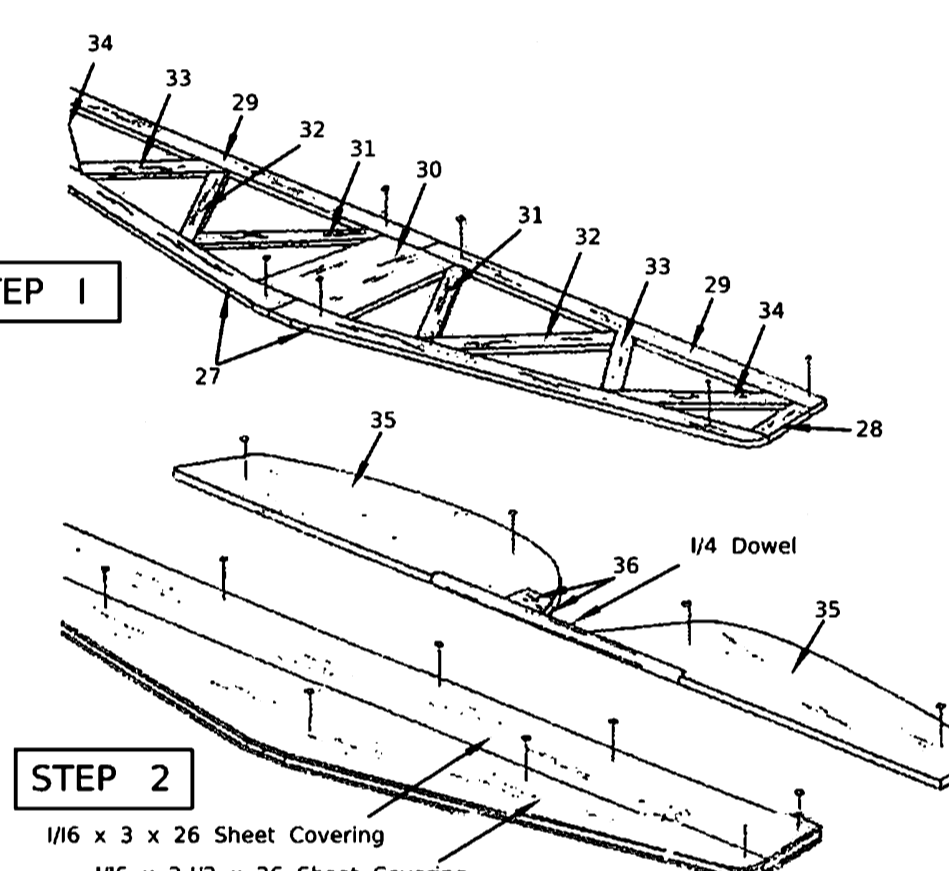
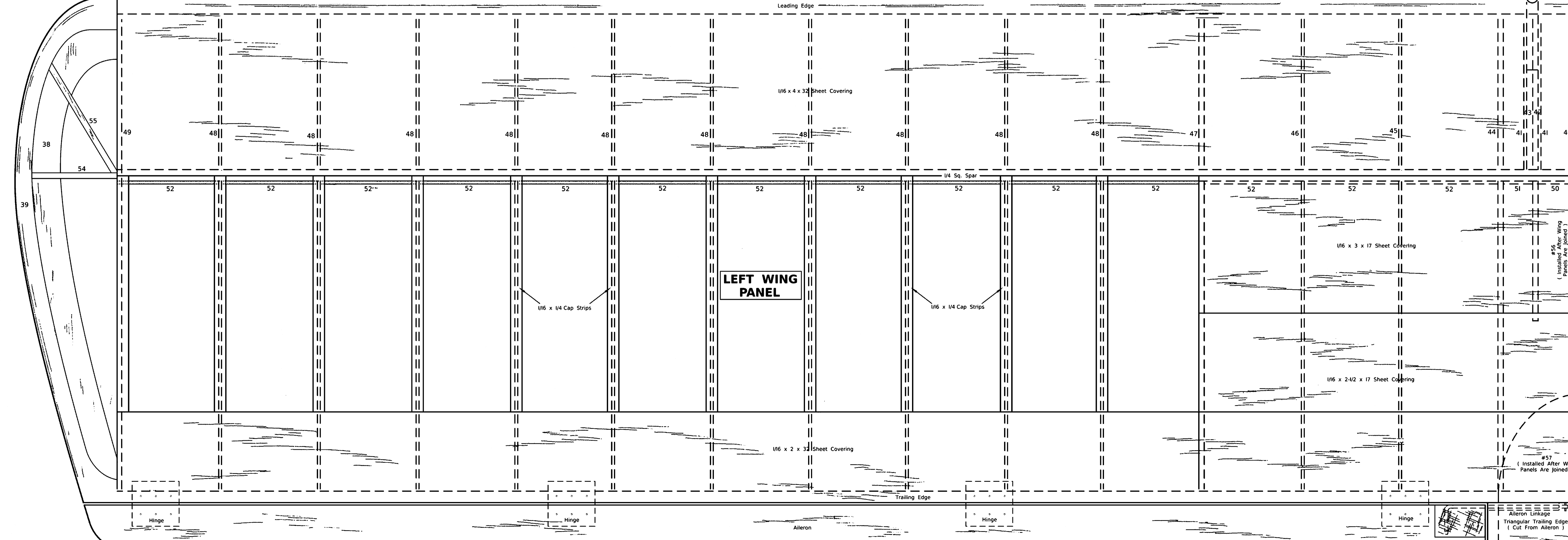
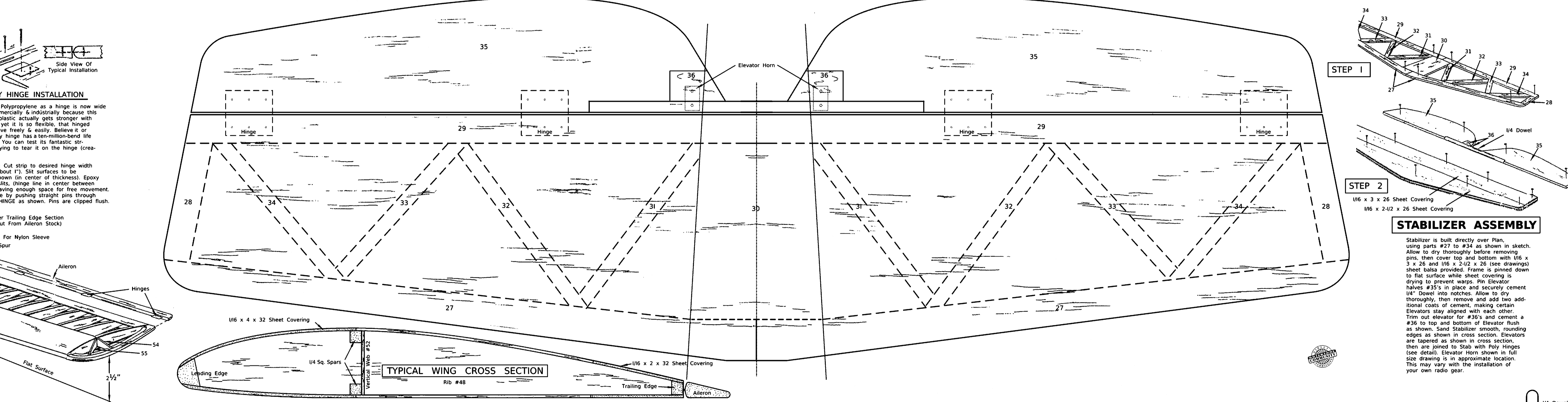
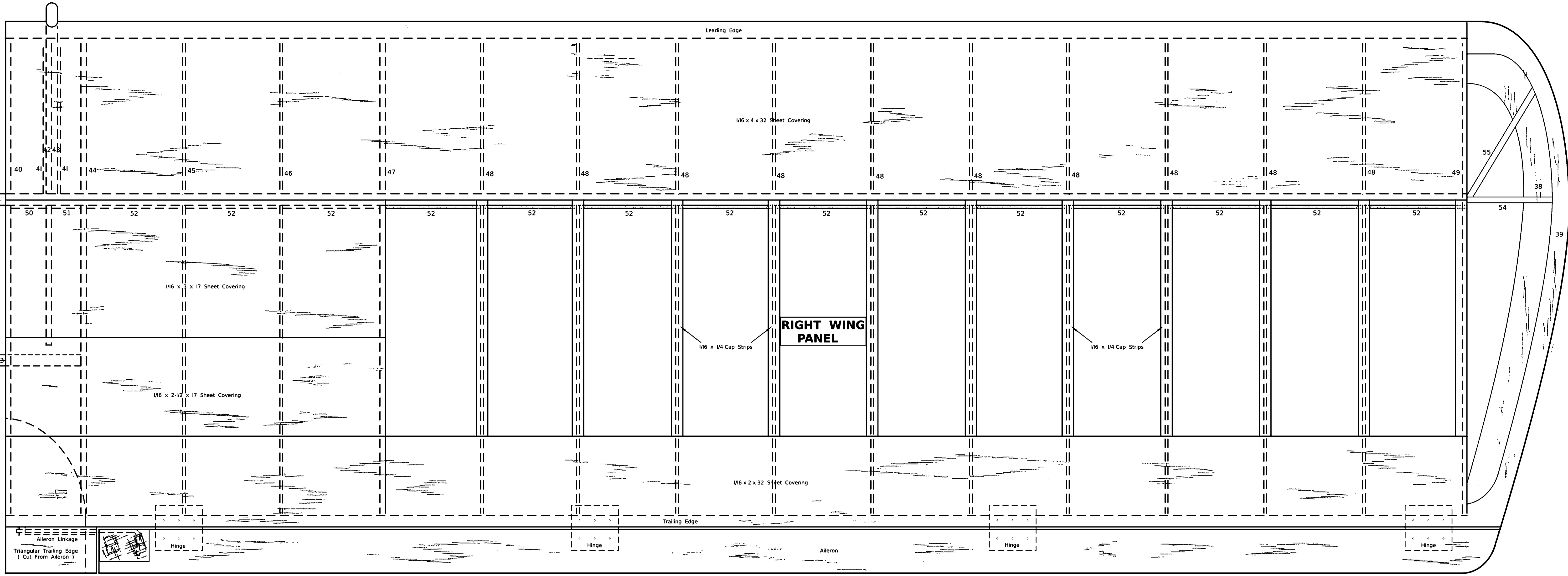

STABILIZER ASSEMBLY
Stabilizer is built directly over Plan, using parts #27 to #34 as shown in sketch. Allow to dry thoroughly before removing pins, then cover top and bottom with U6 x 3 x 26 and U6 x 2 1/2 x 26 (see drawings) sheet balsa provided. Frame is pinned down to flat surface while sheet covering is going to prevent warps. Pin Elevator Holes #35's in place and securely cement U4" Dowel into notches. Allow to dry thoroughly, then remove and add two additional coats of cement, making certain Elevators stay aligned with each other. Trim out elevator for #35's and cement a #36 to top and bottom of Elevator flush as shown. Sand stabilizer smooth, rounding edges as shown in cross section. Elevators are tapered as shown in cross section, then are joined to Stab with Poly Hinges (see detail). Elevator Horn shown in full size drawing is in approximate location. This may vary with the installation of your own radio gear.

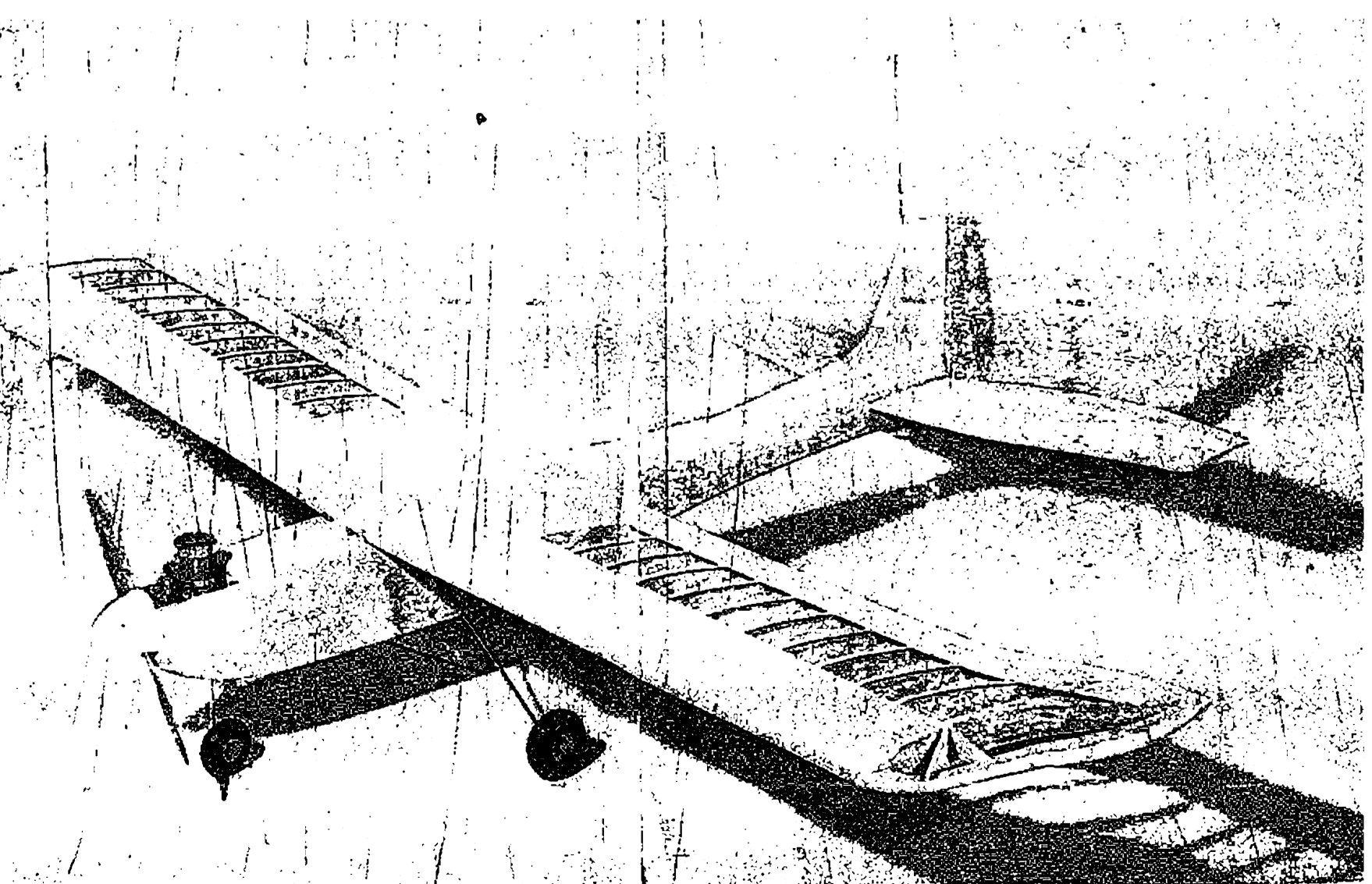

Frame Photo Reveals The Excellent Design Engineering, Combining Simplicity and Strength.

U4" Dowel
Installed After Wing Panels Are Joined
Triangular Trailing Edge (Cut From Aileron)