

### FINAL ASSEMBLY

On R/C models wing is removable as described in R/C Note. For other models cement wing securely in fuselage between bulkheads F2 and F3, lining up ribs W2's under side keel L5. Press wing tightly against L5's to insure proper incidence, otherwise model may not fly! Hold in place with pins until dry. It is necessary to have access to rear hook to replace rubber motor. Cut out stringer immediately above side keel L4 on right side, between F6 and F7. Fit a piece of 1/16" balsa into space. Cement cloth tape to top (half over door and half over fuselage) to act as hinge. Cement a strip of 1/16" sq balsa to top of side keel L4 which will act as stop to keep the door flush with surface. Hold bottom with Scotch tape, trim tissue and cement stabilizer horizontally against rear of F7 between L2 and stringers at top of F8. Cement rudder vertically (into notch) to top of L2. Using patterns provided, cut out rear wing fairings from stiff paper. Cement between wing and fuselage as shown in sketch and 3-View; side point at trailing edge. Small pieces fit below large fairing and against trailing edge. Hold in place with pins until dry. Cut out front fairings and cement in place, on rubber powered models with belly tank drop, cover bottom left side of fuselage from F5 to F6 between L3 and stringer with stiff paper. Assemble and trim all plastic parts, see detail note. When sub-cowl is in place make two cowl frames (see detail note), and cement to front of F1 thru notches in sub-cowl, as shown in Sketch 4. Cement cowl in sub-cowl and at the same time cement front of cowl-frames

into recess on either side of large circle around nose button. Use cement sparingly or it may deform the plastic. Cement wheel covers LG to outside of wire landing gear struts as shown on sketch and side view. Model is now painted. If it is to be painted scale colors, see 3-View drawings or box top. For best flight performance use a minimum of color dope. Apply details by dipping in water and sliding off into position shown. Cut instrument panel from plan and cement to rear of F3 in cockpit. Cement all plastic parts in place as described in detail note. Outlines of scale control surfaces can be drawn on with India Ink. Insert the bearings into wheels and place wheels on axles. Secure by bending up end of axles, or with drop of cement or solder. Insert straight end of propeller shaft thru rear of nose bearing. Slip on two washers provided, and insert shaft through back of propeller. Bend front of shaft to U shape as shown on side view and cement securely to propeller. The ends of rubber securely with square knot, wet with water first to prevent fraying. Double up to make two loops. Insert rubber through trap door and engage on rear hook. Slip remainder of rubber into fuselage and shake down towards nose. Make hook on end of a piece of wire. Slip wire through nose bearing hole in cowl and capture rubber on hook. Pull through cowl and attach rubber on prop shaft. Nose bearing fits into center hole in cowl. Your Japanese Zero A6M3 Model 32 "HAMP" is now complete. See Flight Instructions before flying. GOOD LUCK AND HAPPY LANDINGS!!!

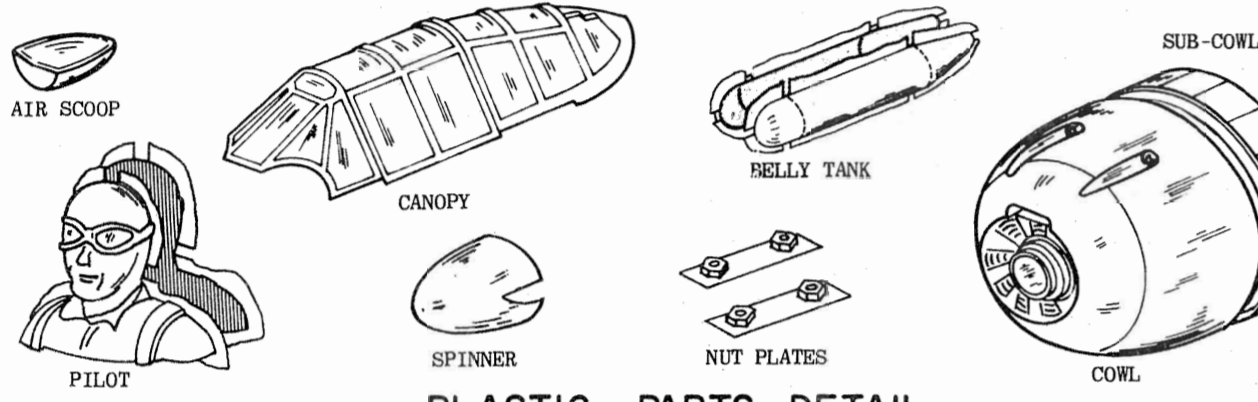

### PLASTIC PARTS DETAIL

For best results, follow instructions carefully. SPINNER: Cut from center of sub-cowl leaving 1/16" excess material for trim. Plastic trims easily. Sand and trim off excess material carefully. Cut out for propeller at scribe lines, then cement spinner to propeller AFTER PROPELLER IS IN PLACE. SUB-COWL: Cut from sheet leaving about 1/16" of material for trim. Slip sub-cowl over bulkhead F1, to F2, for support while trimming excess material away. Cut out long notches marked in plastic where cowl frame will be inserted when it is cemented against F1. Cement in place against F1 with cut outs vertical, and center line of the 5 scribe lines centered on left L4. Use cement VERY SPARINGLY. Excessive use of cement will melt and distort plastic. COWL: Cut from sheet leaving 1/16" excess for trim. Rear of cowl fits into step of sub-cowl at F1. Trim to fit. Machine gun troughs are the top of cowl. AIR SCOOP: Cut from sheet, trim; then cement to bottom center of cowl at F1 as shown on side view. PILOT: Cut both halves from sheet leaving about 1/8" excess material. Carefully cut out slots about 1/8" wide on top, sides and bottom, right to the edge of the pilot halves as shown. This will permit accurate assembly. Cement halves together, lining up carefully

at slots. Use cement VERY SPARINGLY, since excessive use may distort or melt plastic. After assembly is thoroughly dry, trim and sand off smooth. BELLY TANK: Cut both halves from sheet and assemble with slots in same manner as pilot. When dry, trim and sand smooth. Two "U" shaped wire guides made as described in tank release note. Install at locations shown in tank sketch #2. Make pin holes, then insert and cement guides in place. NUT PLATES: Cut from sheet on trim lines and install as described in Engine Installation. CANOPY: Trim edges and fit in place on fuselage. Paint raised portions (frame) of canopy same color as fuselage. AFTER READING PAINT INSTRUCTIONS AT END OF THIS NOTE! PAINTING: Use regular plastic model paint or enamel. Model airplane dope can be used if necessary but only if applied in LIGHT SPRAY COATS, allowing paint to dry thoroughly between coats. Excessive use of dope may deform plastic. Parts may be used red, or if painting a lighter color, apply a light coat of silver, followed by a light coat of white, before painting final color. Darker colors may be applied directly to red plastic. Remember when using cement on plastic, use light coats applied sparingly. If necessary, use more than one coat, but DO NOT APPLY A THICK COAT AT ANY TIME.

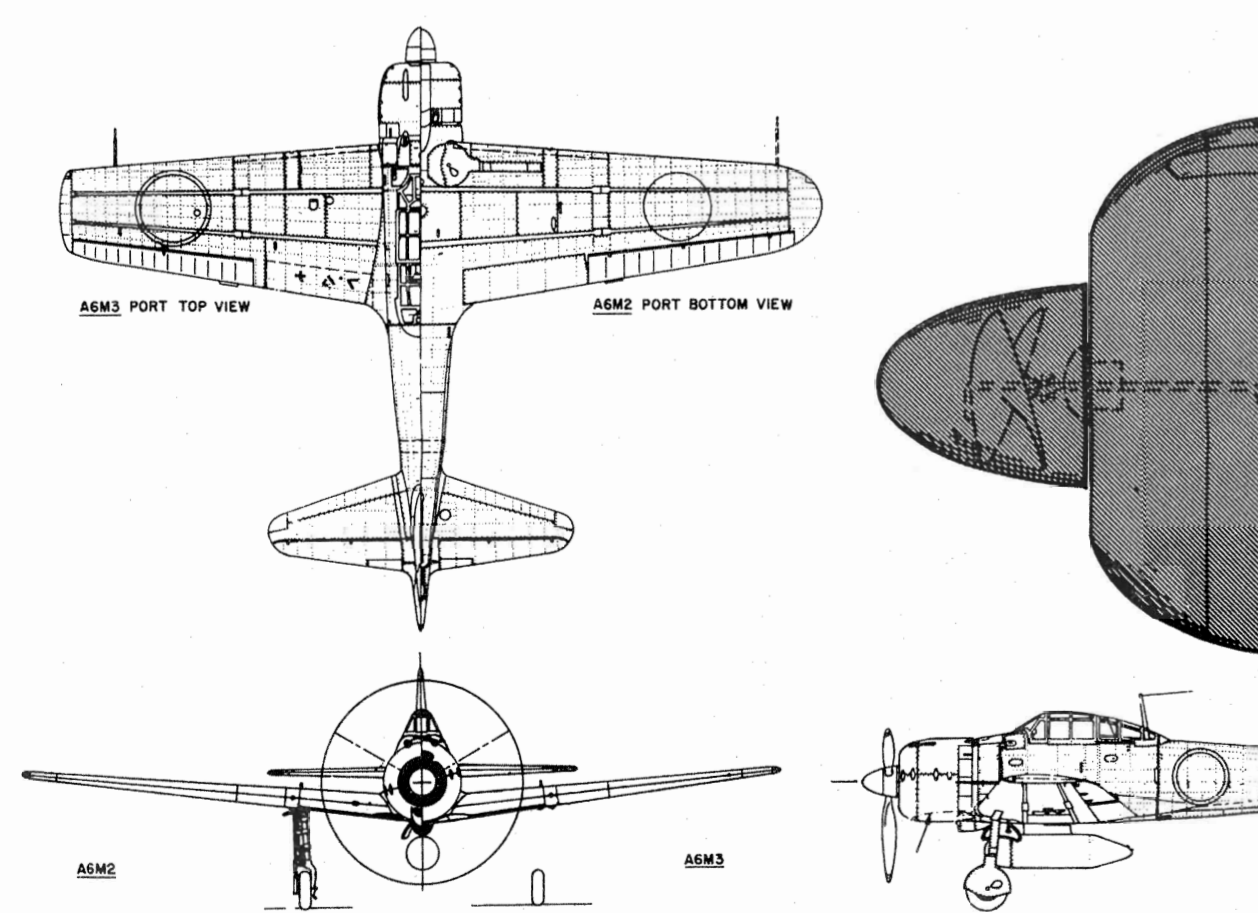
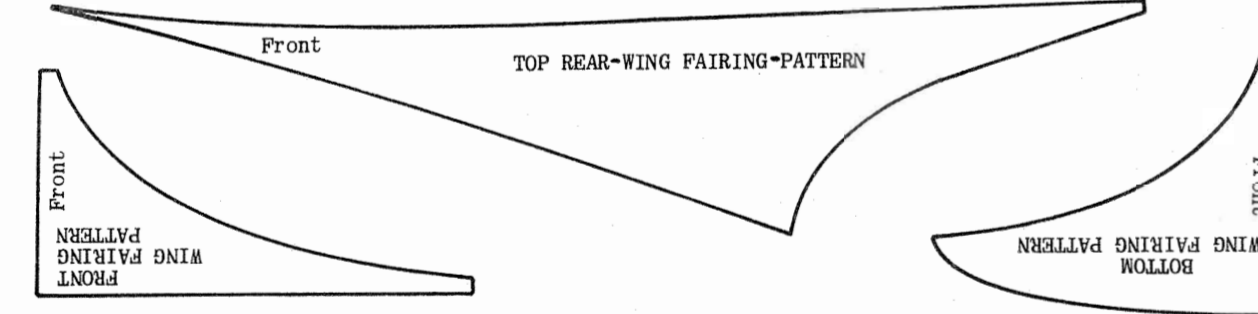

### ZERO A6M3 MODEL 32 "HAMP" SPECIFICATIONS AND COLOR SCHEME

Wing Span - 36 Ft. 1"	Empty Weight - 3860 Lbs.	COLOR SCHEME: See box lid for authentic color scheme, details for which are provided in kit. Also widely used color scheme was a brownish olive green on upper surface with a warm light grey underside. Tips of propeller painted red. Colors varied somewhat with location and type of operation.
Length - 29 Ft. 9"	Gross Weight - 5920 Lbs.	
Height - 9 Ft. 2"	Armament - Two 20 MM Cannon	
Maximum Speed - 347 M.P.H. (at 20,000 Ft.)	Wing - Two 7.7 MM Machine Guns in	
Engine - Sakae 21-14 Cyl.	Fuselage	
130 Horse Power	Four 16 Kg or Two 30 Kg Bombs	
Propeller - 10 Ft. 0 In. Sumitomo, Hamilton		

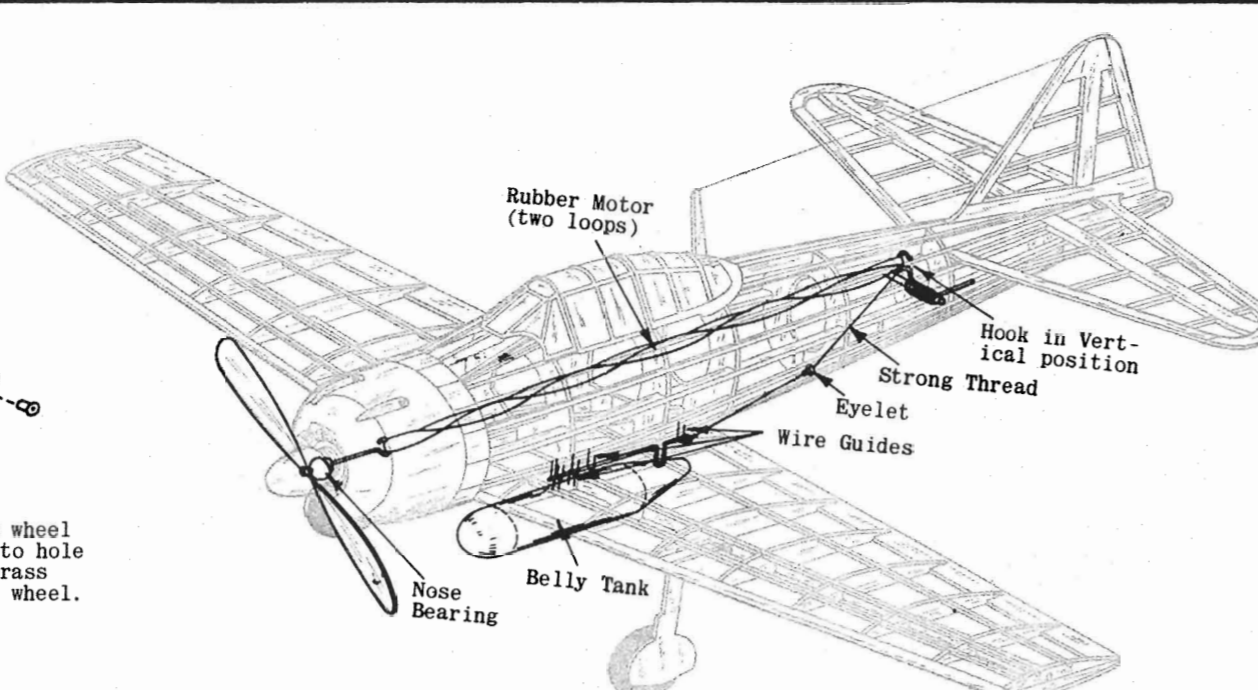

### AUTOMATIC BELLY TANK RELEASE

Belly tank dropping is operational in flight, on rubber powered models only, using spring rear hook. For engine powered models see Control Line or R/C Note. Installation is simple and action is positive, if directions are followed carefully. Make hole and cement eyelet in bulkhead F6, beside top of L3 on left side. Bend 7 "0" shaped guides from straight pins, using pattern provided. Make tank release pin from 1/32 wire, using full size pattern. Cement five guides in place to center bottom of wing, see Tank Release Detail Sketch 1. Assemble tank as described in Plastic Parts Detail and cement guides in place to tank as shown. Insert thread in hook, thru eyelet and hole made in stiff paper covering as shown. Insert tank release pin through guides and securely tie thread to hook with handle against rear guide as shown.

Spring rear hook is in vertical position. Thread should be snug when release pin is in this position. Coat knot on release pin with cement. This completes mechanism. To operate, wind rubber motor; if directions are followed carefully. This will pull rear hook forward from a vertical to a horizontal position, loosening thread. This now permits release pin to go forward past front guide to position shown in Sketch 2. Hold tank in place between first two guides and insert pin, past front guide, engaging bomb at same time. Push pin forward until line is snug. Tank is now loaded. Model is now released and towards the end of the flight when motor unwinds, rear hook pulls back into a vertical position, tightening line. This pulls release pin past third guide, releasing and dropping tank.

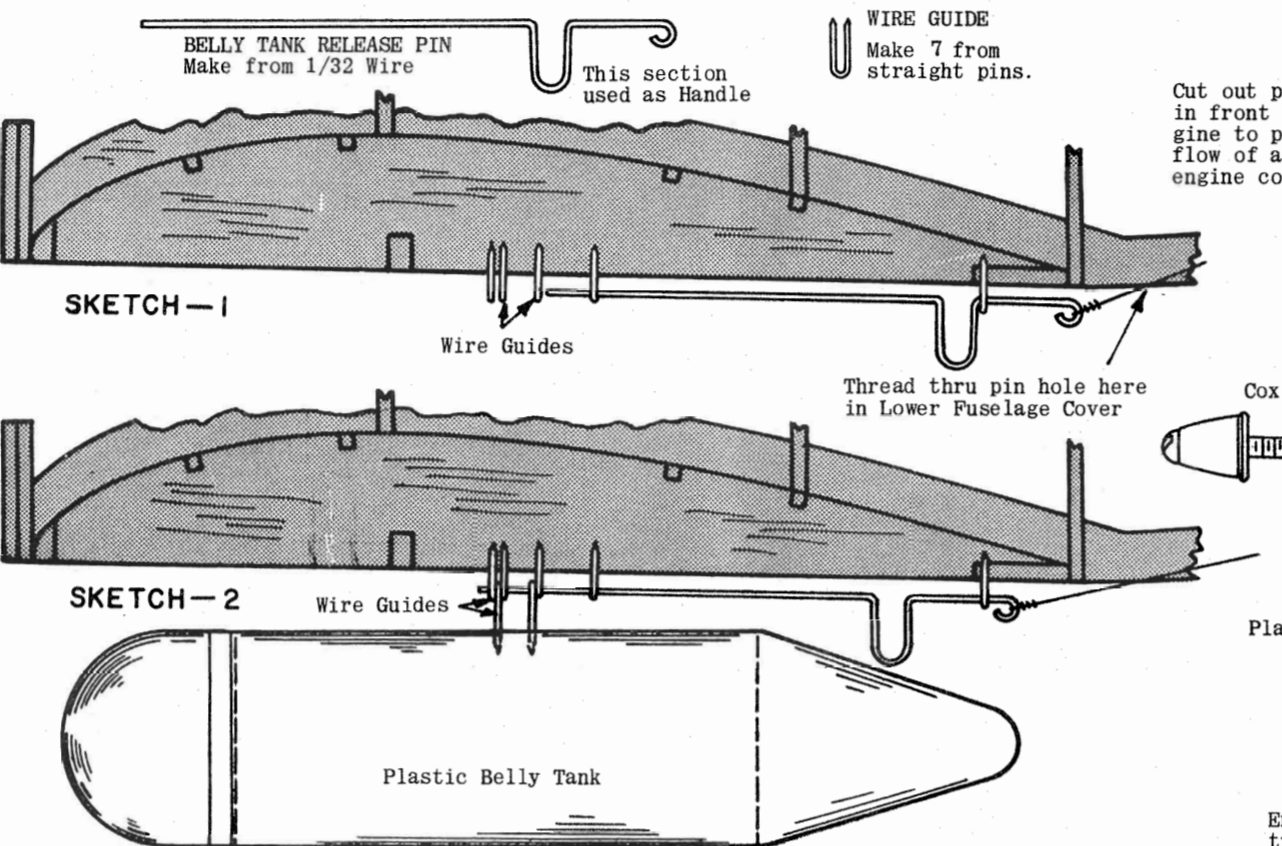

### BELLY TANK INSTALLATION

Prepare installation by bending 7 wire guides from pins, and tank release pin from 1/32 wire, using full size patterns above. Cement five guides in exact position shown on Sketch #1, centering over joint between center wing ribs W1's. All guides must be the same level, about 1/8" below bottom of ribs as shown. Sketch #1 shows front of tank release pin at 3rd guide when motor is unwound and rear hook is in vertical position, and thread snug. Sketch #2 shows position of tank release pin when motor

is wound, and rear hook is in horizontal position. Thread is now loose, permitting front of release pin to be inserted through guides on tank and front guide on wing rib, securing tank in place. Sketch #2 is also used for location of guides in tank as described in Plastic Parts detail. When motor unwinds, hook pulls back to vertical position, pulling release pin out of front two guides, releasing tank.

**CAUTION:**  
Do not fly control line models in the vicinity of electric power lines!

© STERLING MODELS 1964  
This material may not be used except with written permission of Sterling Models  
Patent Pending-All Rights Reserved

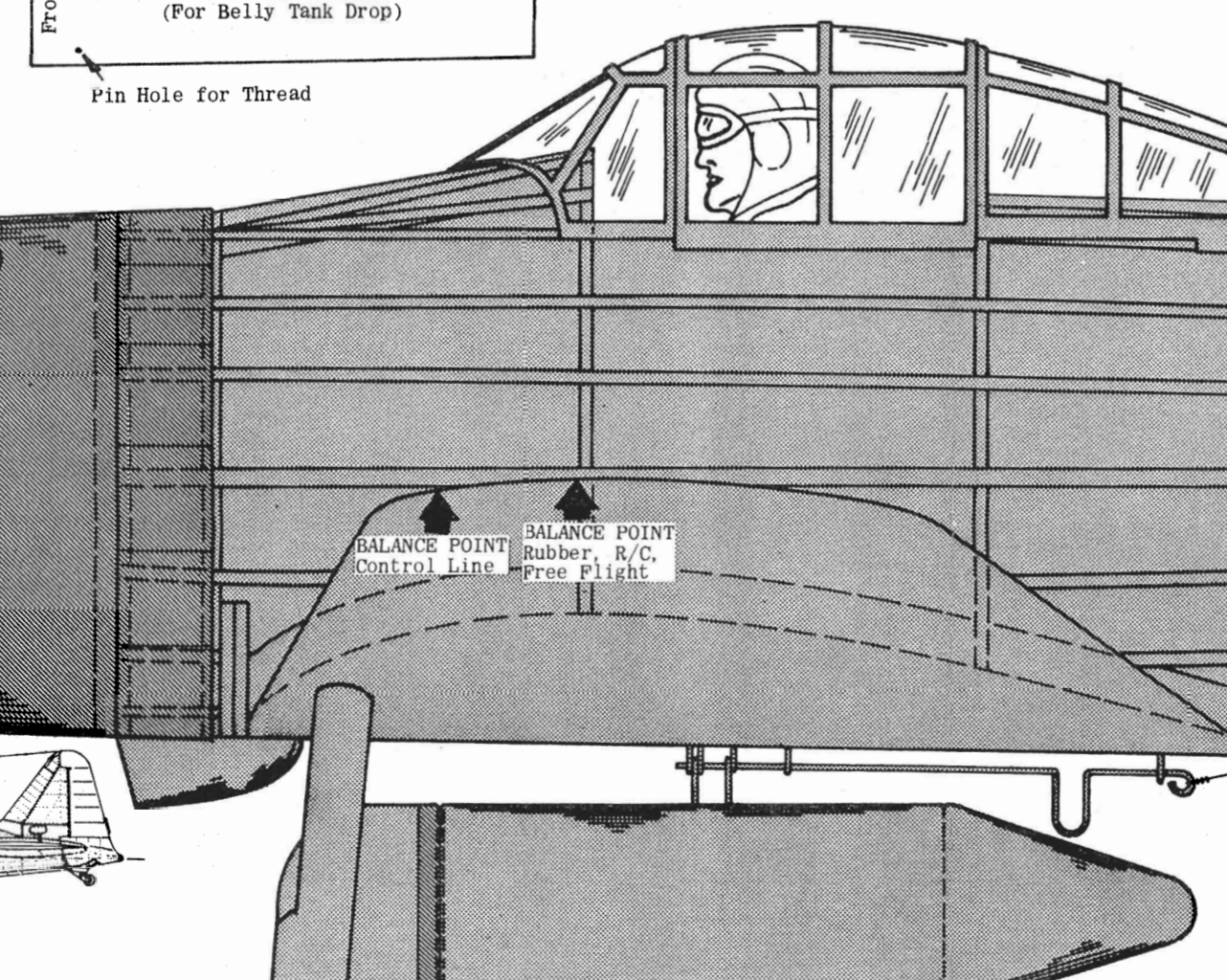

### FLIGHT INSTRUCTIONS

When model has been completed, it must balance at point shown on side view. DO NOT ATTEMPT TO FLY MODEL UNTIL PROPER BALANCE HAS BEEN ACHIEVED, and weight if necessary. Model is now ready. Pick a calm day for test flying. For rubber powered models, wind propeller clockwise approximately 100 turns and launch into any prevailing wind slightly nose down at a point on the ground approximately 50 feet ahead of you. If model noses up and then falls off and stalls. (AFTER MODEL WAS BALANCED) then bend elevators down slightly using hot breath in same manner as steam. If model dives, bend elevators up. If model veers too much to one side, bend rudder to opposite side. Take offs require more power and therefore more turns in rubber motor. For longer flights and competition, it is recommended that the loops of

rubber be lubricated with model lubricant (available at most hobby shops) or Castor Oil. Apply sparingly AND KEEP OFF KNOT OR IT WILL COME UNDONE! Use rubber which can stand tightening hook into hand drill. To store winds in motor, stretch rubber out three to five times original length, then proceed to wind, moving slowly back to model. Feeling rubber from time to time to be certain it does not get so taut that it breaks. Upon reaching the nose, motor should be completely wound. When replacing rubber motor, purchase best grade T56 brown rubber at your favorite hobby shop. Engine powered free flight models are tested and flown in same basic manner as above and is described in Flight Instructions at end of Radio Control Installation Note. GOOD LUCK AND GOOD FLYING!!!

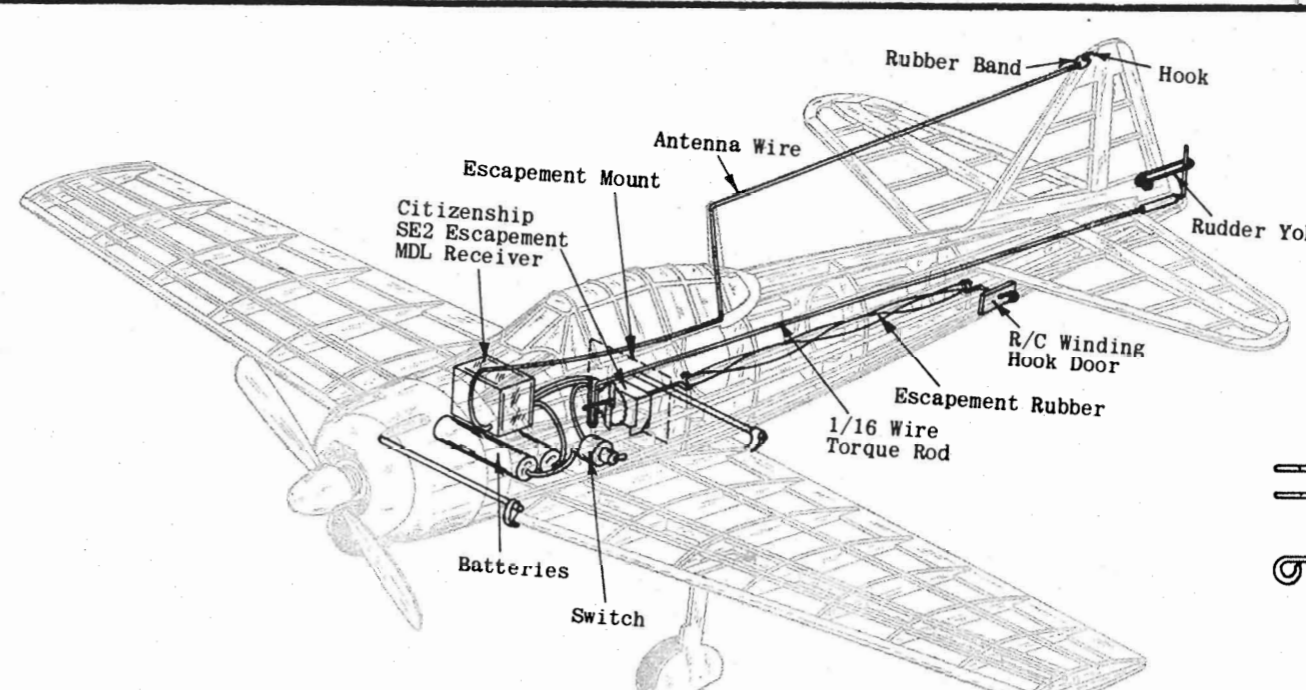

### RADIO CONTROL INSTALLATION

Test models used, and drawing shows, Citizen-Ship MDL Receiver, SE2 Escapement; used with SPX Transmitter. This equipment and other material necessary is not provided in kit. On radio models wing is removed. Pin, BUT DO NOT CEMENT, wing into position as described in Final Assembly. Cement a 3" length of 1/8" dowel across top of F2's and rear of F5 on top of center keel. Dowels protrude evenly from fuselage on both sides. Remove center keel L3 between F2 and F4. Front half of entire fuselage should be covered with 1/32 sheet balsa. Balsa is also covered with silkspan as described in note. Cut rudder apart at location shown by dotted lines, then assemble together with cloth hinges. Bend wire yoke from 1/32 wire and install on rudder with 2/56 nut and bolt. Cut escapement base from 1/16 plywood and cement to front of F4. When dry, install escapement with 2/56 nuts and bolts. Insert an 18" length of 1/16 wire through slot made in rear of L3 for torque rod. Bend U in

front of rod according to R/C manufacturer's instructions and shown above, then pull back and engage in escapement as shown. Bend rear as shown. Cut off excess wire, then engage in yoke. Raising and lowering yoke will increase or decrease the amount of rudder movement. Batteries are stored horizontally in section between F2 and F3. Receiver is located between F2 and F3 above batteries. Wire radio equipment in accordance with manufacturer's instructions. After unit is wired, line compartment with foam rubber and insert receiver followed by batteries which are also surrounded in foam rubber. Insert into compartment, being careful not to break any wire connections. Bend small hook for antenna and cement to front of rudder. Bring antenna out of cockpit and fasten to hook with rubber band. When model has been completely finished, it must balance as shown on side view. If necessary add weight but DO NOT ATTEMPT TO FLY UNTIL BALANCE HAS BEEN ACHIEVED.

Check wings and tail for warps, if any have developed, remove with steam method as described in Covering Instructions. Wait for calm weather for test flights. Field test R/C equipment before flying as described in manufacturer's instructions. Start engine and THROTTLE DOWN TO LOW SPEED, then launch model with nose pointed slightly down at a point 50 or 60 feet in front of you and release at approximate flying speed. Model should fly in a straight line and either maintain or slightly lose altitude. If model turns to either side, rudder or engine may be off set to opposite side to achieve a straight flight, which is how it should glide and fly. If model glides well but stalls under power, point front of engine down (down thrust) by placing wedge behind top of tank. Increase engine RPM as adjustments are made, checking R/C controls before each flight. GOOD LUCK AND GOOD FLYING!!!

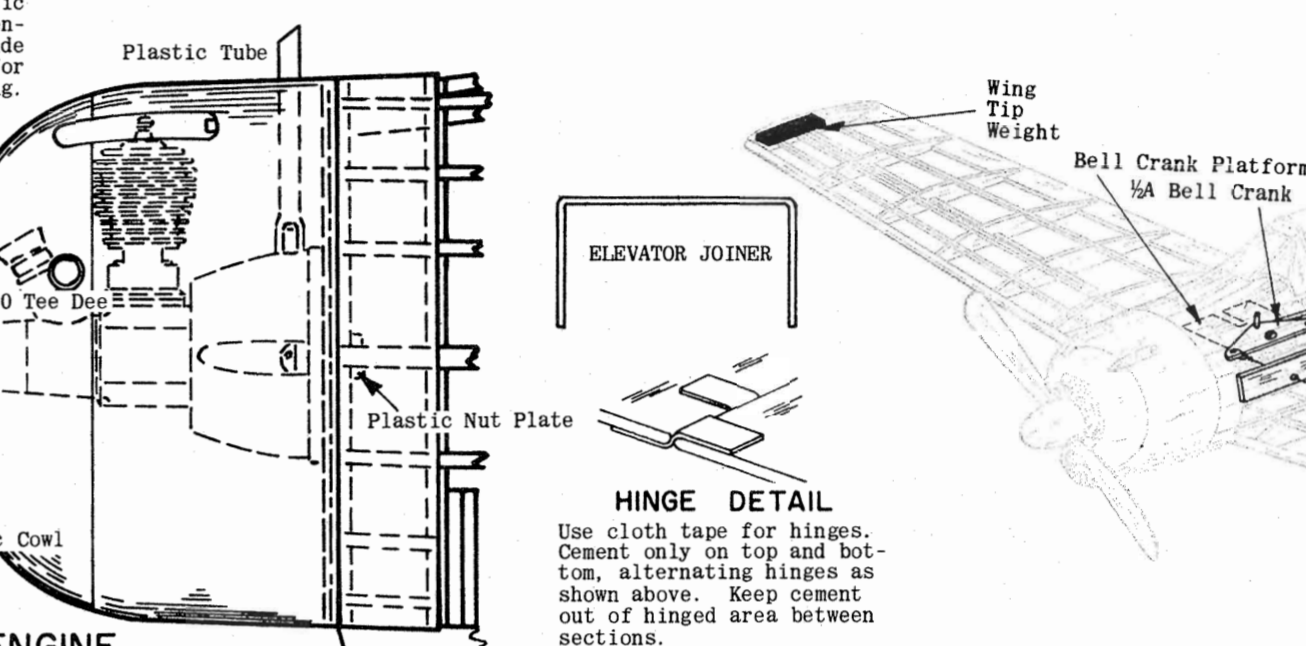

### ENGINE INSTALLATION

Engine is used if model is being built for control line, free flight or radio. Engine and installation material not provided in kit. Drawing shows installation of Cox .020 Tee Bee Engine, however, any other similar engine may be used. Drill 1/8" holes at punch marks in plywood fire wall. Mount engine with #2 nuts and bolts. Cut plastic nut plates from molded sheet and securely cement to back of fire wall over nuts, drilling holes through, so that bolts can protrude. Use cement generously. Nut plate keeps nuts from turning, so engine can be removed by just unscrewing bolts from front. When dry, remove engine and securely cement engine fire wall to front of F1. Cut molded engine cowl from plastic sheet as described in detail note and fit over sub-cowl. Trim out top three cylinders in front of cowl, and also top front of cowl, for cooling. Make needle valve extension by forcing a length of 1/8" I.D. plastic fuel tubing over head of needle valve, then forcing a length of 1/8" dowel into end of tubing. Dowel should protrude at least 1/2" past cowl. Cut 1/16" I.D. plastic tubing for filler and overflow, and force tubing on tubes on top of fuel tank. Tubing should extend about 1/2" past cowl and top should be cut at angle facing forward for easy admission of air stream. Slot cowl for plastic tubes. Slots extend to rear of cowl so it can be removed. Cowl can be either tack glued or held with small wood screws. Remove needle valve from engine to rudder. Cowl is installed after model is painted and replaced on model.

### CONTROL LINE INSTALLATION

Install controls after Fuselage Step 4 has been completed. Fill in area between F2 to F4, from side keel L4 to stringer above it, with scrap 1/16" sheet balsa. Flush with outside of frame; also area from F7 to F8, between L4 and stringer above, in same manner. Cut 1/8" slot in rear for control rod as shown. Cut two 18" lengths of lead-out lines (not provided in kit) and fasten them to bell crank. Mount bell crank on plywood platform as shown in Detail Sketch. Lead-out lines come through fuselage at holes drilled for them as shown. Cover fuselage with tissue as described in detail note. Cut stabilizer through wide main spars, as indicated by dotted lines on full size drawings. Bend "U" shape elevator joiner from wire. Trim center of stabilizer for clearance and cement spurs to both elevators in position shown. Elevators now move as one unit. Round edges and install control horn at location shown on drawing, then join together with cloth hinges shown. Cement stabilizer to fuselage as described in Final Assembly Note, including the now separate rear center section. Tape elevators in neutral position (in line with stabilizer, neither up or down). Bend 1/4" of one end of 1/16" wire for control line when flying your Japanese Zero A6M3 Model 32 "HAMP". GOOD LUCK AND GOOD FLYING!!!

### CONTROL ASSEMBLY

Drill 1/8" hole thru plywood platform. Insert bolt thru bell crank and run nut up bolt till bell crank has just enough room to swing freely, closed face of nut down. Insert thru platform and install bottom nut closed face up. Tighten nut towards each other leaving bell crank to pivot freely. Secure nuts with solder or glue.

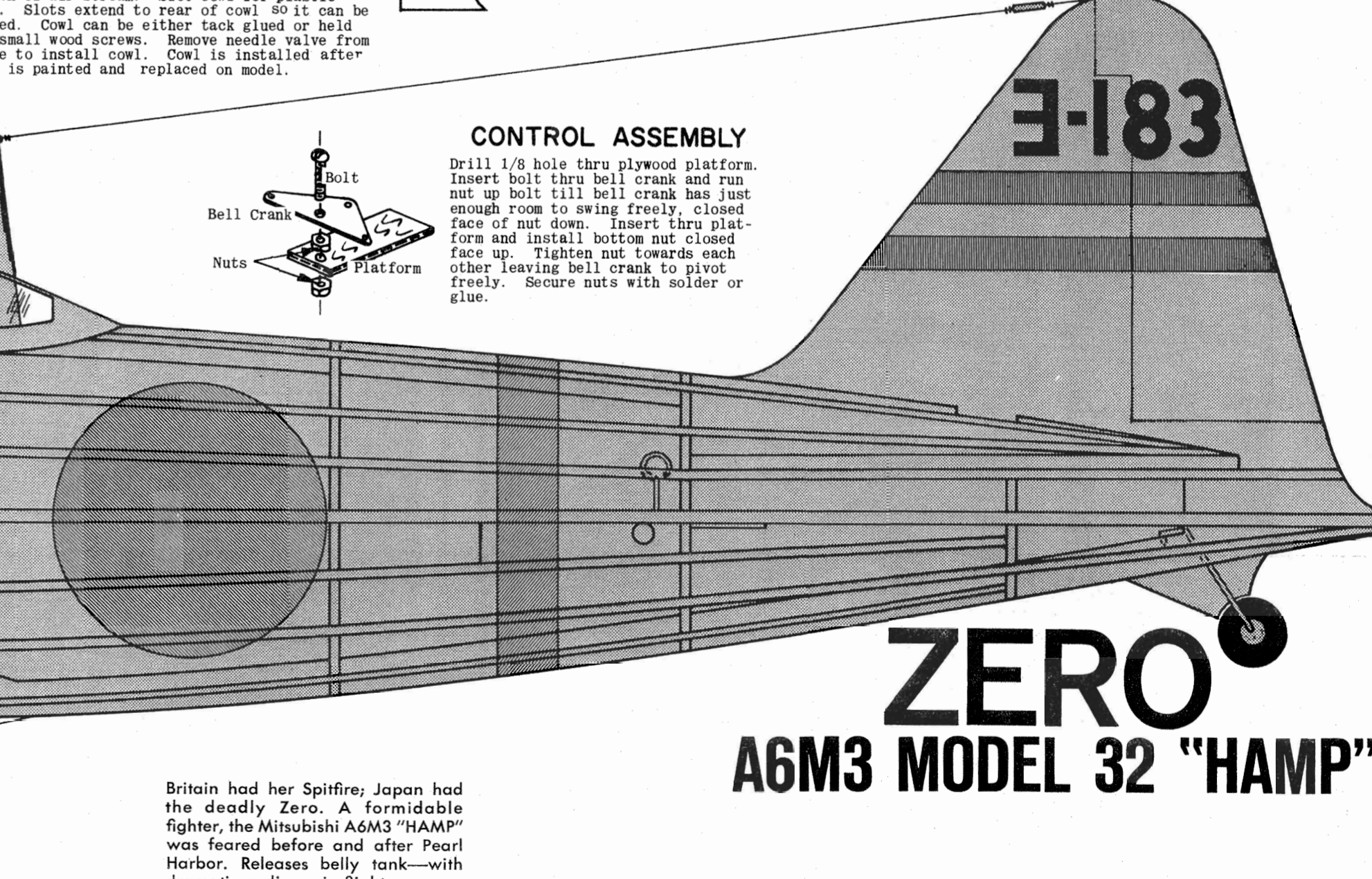

# ZERO A6M3 MODEL 32 "HAMP"

Britain had her Spitfire; Japan had the deadly Zero. A formidable fighter, the Mitsubishi A6M3 "HAMP" was feared before and after Pearl Harbor. Releases belly tank—with dramatic realism—in flight.

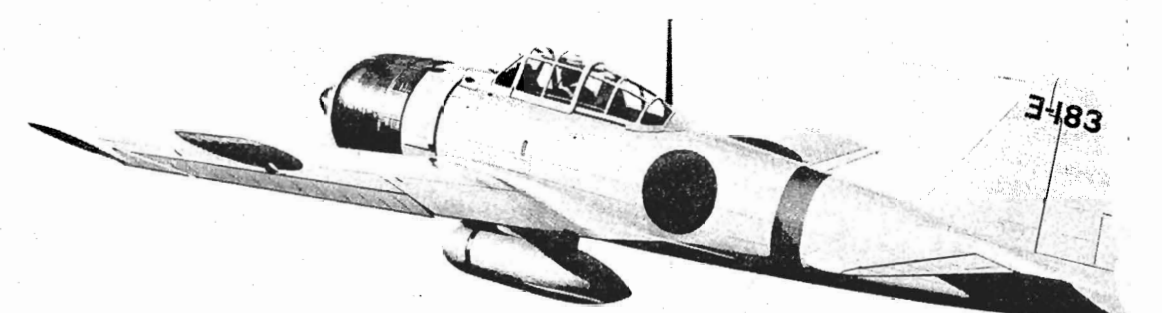

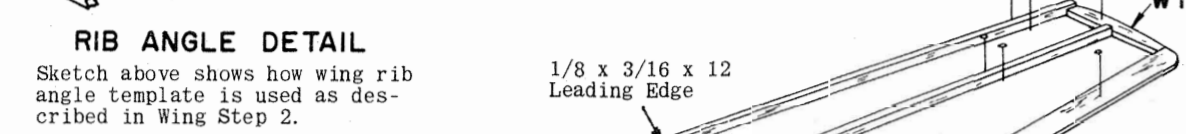
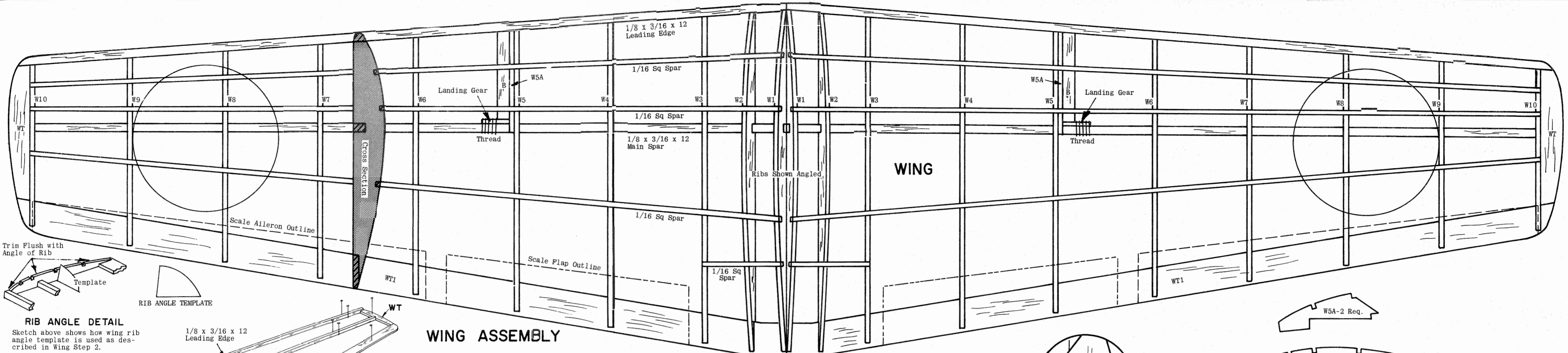

**WING ASSEMBLY**

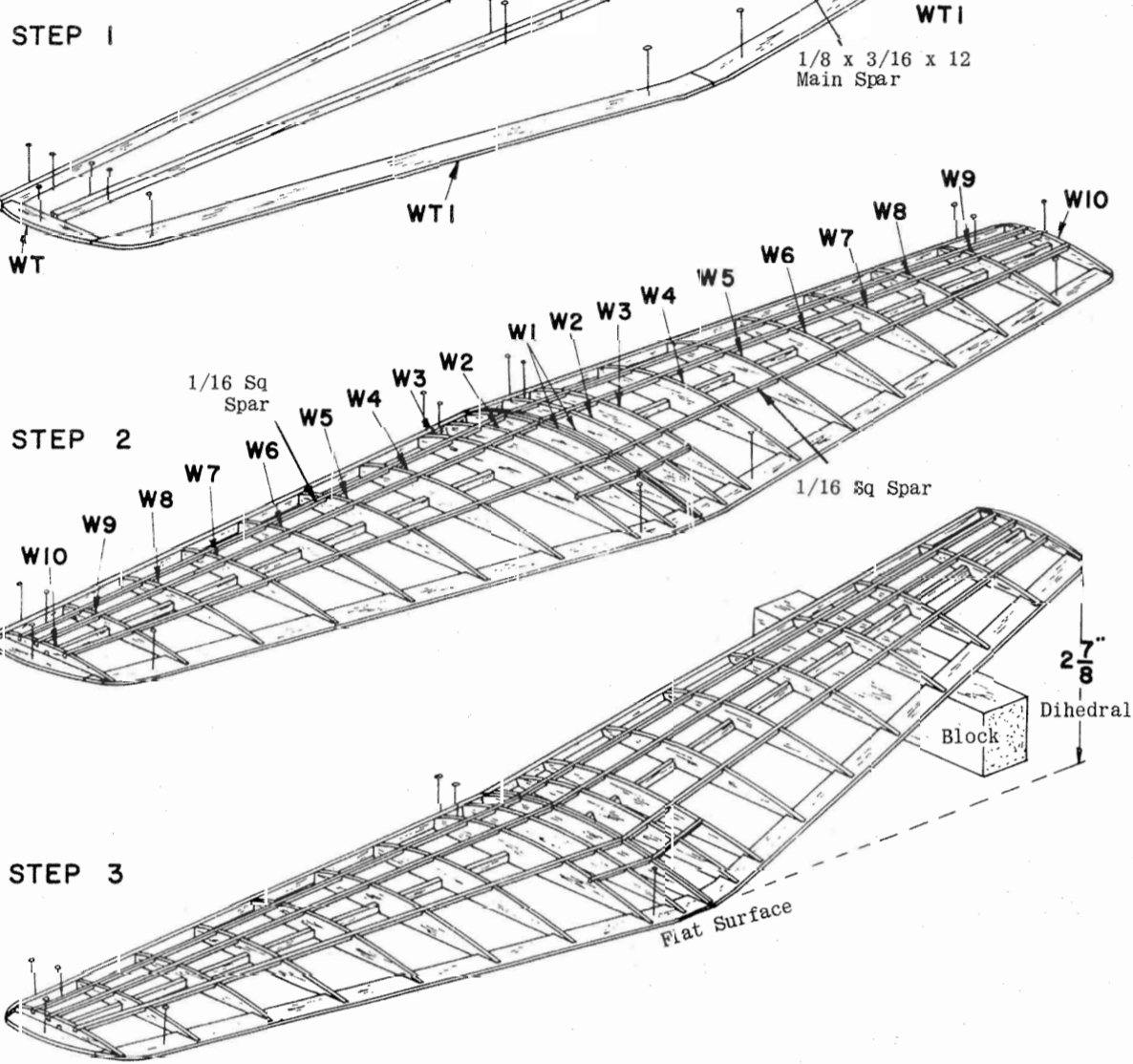

**STEP 1**  
Pin all WT parts in place, cementing them to each other where they join. Cut 1/8 x 3/16 x 12 main spars to proper length. Pin in place in upright position, joining directly over center and cement to WT's. 1/8 x 3/16 x 12 is also used for leading edge. Pin in place in upright position, cement to front of WT's.

**STEP 2**  
Ribs W1's to W10's are now cemented in place. Center ribs W1's are angled, using rib angle template as shown in detail sketch. This insures proper dihedral angle. Ribs W2's are also angled in same manner with same template so that they fit under fuselage side keels L5 properly. All other ribs are vertical. Cement 1/16 sq spars into notches along top of ribs as shown. Trim leading edge flat at center and to curve of tips. Allow frame to dry thoroughly (overnight recommended) before removing from flat surface.

**STEP 3**  
Trim and sand leading edge to shape shown on wing cross section, then round off tips and trailing edge to blend smoothly into each other. Leading edge, spars and trailing edge are trimmed flush with angle of ribs W1. Cement halves together on flat surface, blocking up one side 2-7/8 as shown. Measurement must be the same at leading and trailing edge so that wing is not warped. Other panel is weighted or pinned to keep flat on surface. Use cement generously and allow to dry thoroughly. Completed wing frame is now removed from flat surface and landing gear installation as shown on final assembly sketch is now made. Cement landing gear support ribs W5A to outer side of ribs W5. **FLUSH WITH TOP.** Landing gears are now cemented securely in place as shown. Top of gear rests against bottom of W5A which is angled providing forward angle to landing gear. Rear is tied securely to spar with thread as shown on sketch and wing plan. Axles face inward towards each other. B is now cemented to bottom of W5A flush with bottom of rib W5. When installation is complete, apply a second heavy coat of cement and allow to dry thoroughly. Wing frame is now sanded smooth to prepare for tissue covering.

**SILKSPAN TISSUE COVERING**

The finest grade wet strength silkspan tissue provided in this kit permits covering of compound curves without wrinkling, when moistened with water before applying to frame. Tissue shrinks when dry to tight smooth surface. Use clear dope to attach tissue as follows: Apply a light coat to the outside edges of area to be covered. When dry, cut tissue to shape needed, about 1/4" over size. Place tissue on flat surface and dampen with moistened cloth by dabbing. Apply a second coat of clear dope to outer edges, then place moistened tissue on frame. Pull tissue gently with fingers, working out all wrinkles. **WHEN COVERING WING AND TAIL SURFACES, PIN FRAMEWORK TO FLAT SURFACE TO PREVENT WARPS AS TISSUE DRIES.** Cut out any wrinkled areas (bounded by nearest framework) and recover. Apply two or three coats of clear dope, thinned 50-50 with thinner, on wing and tail surfaces before assembling to model. **COVER WING FIRST.** On control line models, add about 1/2 ounce of weight to wing tip on outside of circle flow. Cover bottom of wing on both sides from W1 to tips, with one piece for each section. Cover top of wing from W1 to W10 with 1 piece, cover tips with separate small pieces. **COVER TAIL SURFACES NEXT:** Cover both sides of rudder and stabilizer in one piece each. **COVER FUSELAGE NEXT:** Cover fuselage sides from second stringer on bottom, to top full length stringer, in one piece. Likewise from top full length stringer to next one above. Space between rear stringer and top of stabilizer filled in with scrap balsa. After stab is installed in final assembly. Cover top back to F3 in one piece. Cover top rear from F4 back in one piece. Cover bottom rear in two pieces, joined on L3. Apply four coats of thinned dope to tissue covering on fuselage. Check wings and tail surfaces for warps before assembly. Warps can be removed by holding over steam (from boiling kettle) and twisting gently in opposite direction. Check again when cool.

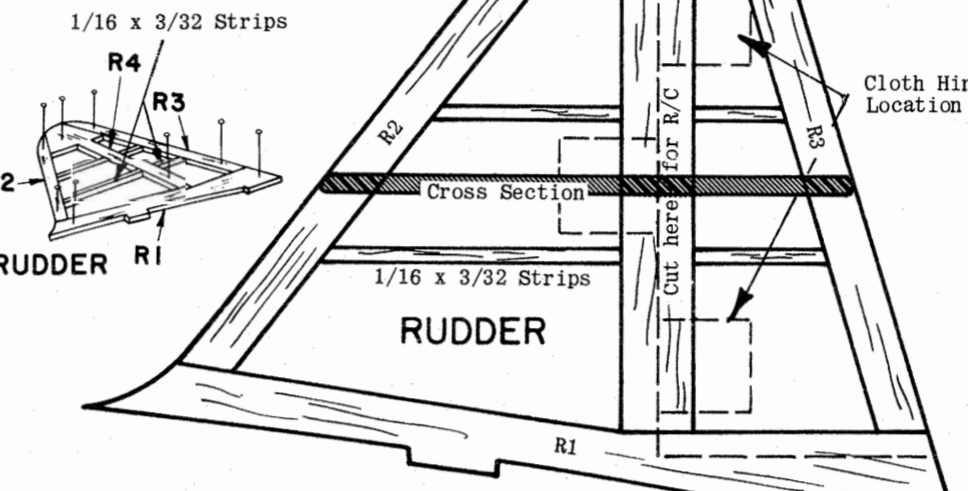

**TAIL SURFACE ASSEMBLY**

Assemble stabilizer by pinning all S parts to plan on flat surface, cementing them to each other where they join. Cut 1/16 x 3/32 strips to fit and cement in place upright. Don't forget short sections across center of S1's and S2's. Rudder is built in same manner, pinning all R parts to plan and cementing them to each other. 1/16 x 3/32 strips are then added. Allow assemblies to dry thoroughly on flat surface, then sand smooth, rounding edges except bottom of R1, as shown on cross-section. If model is being constructed for Control Line or Radio, see respective notes **BEFORE COVERING WITH TISSUE.**

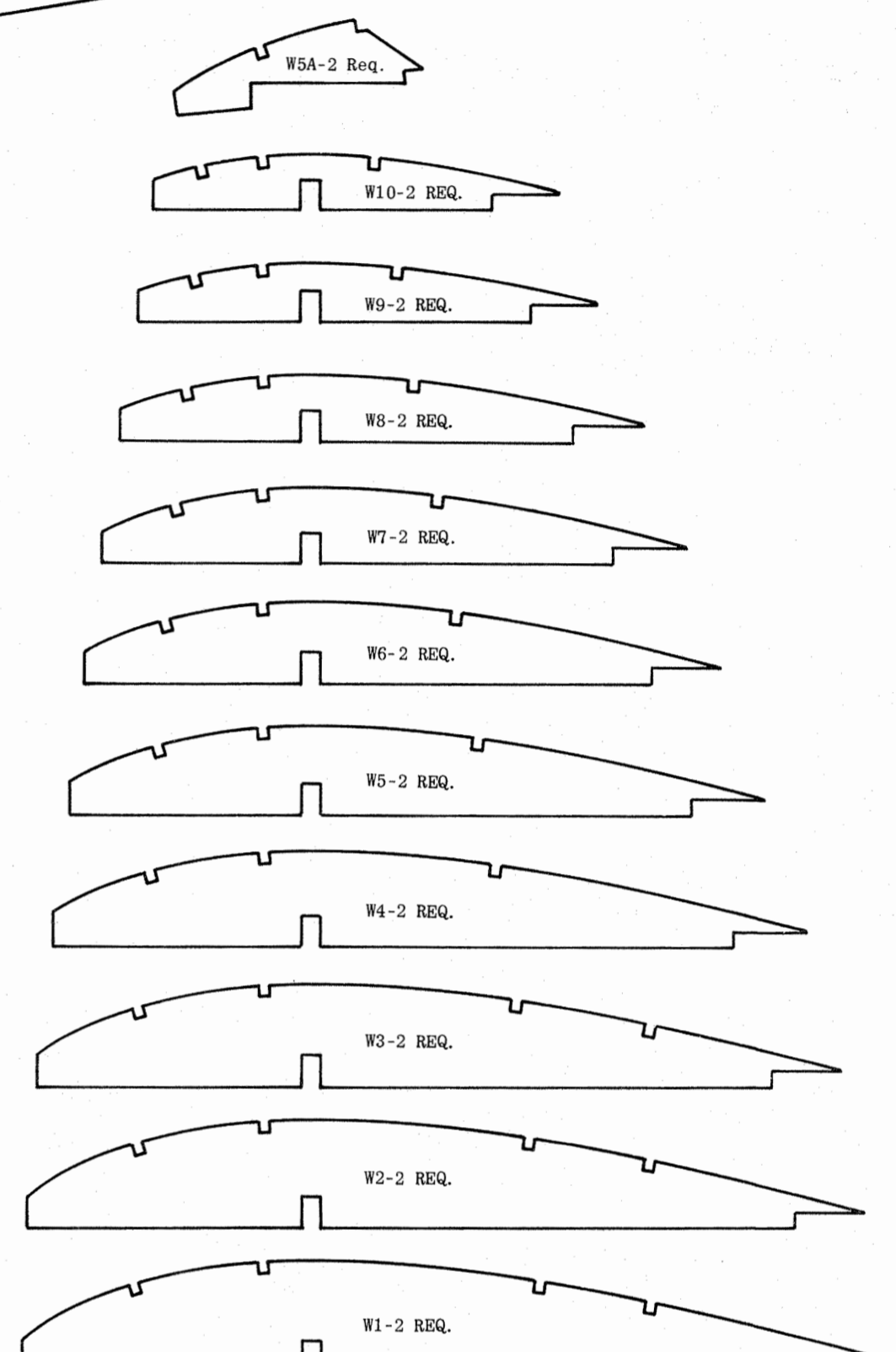

**FUSELAGE ASSEMBLY**

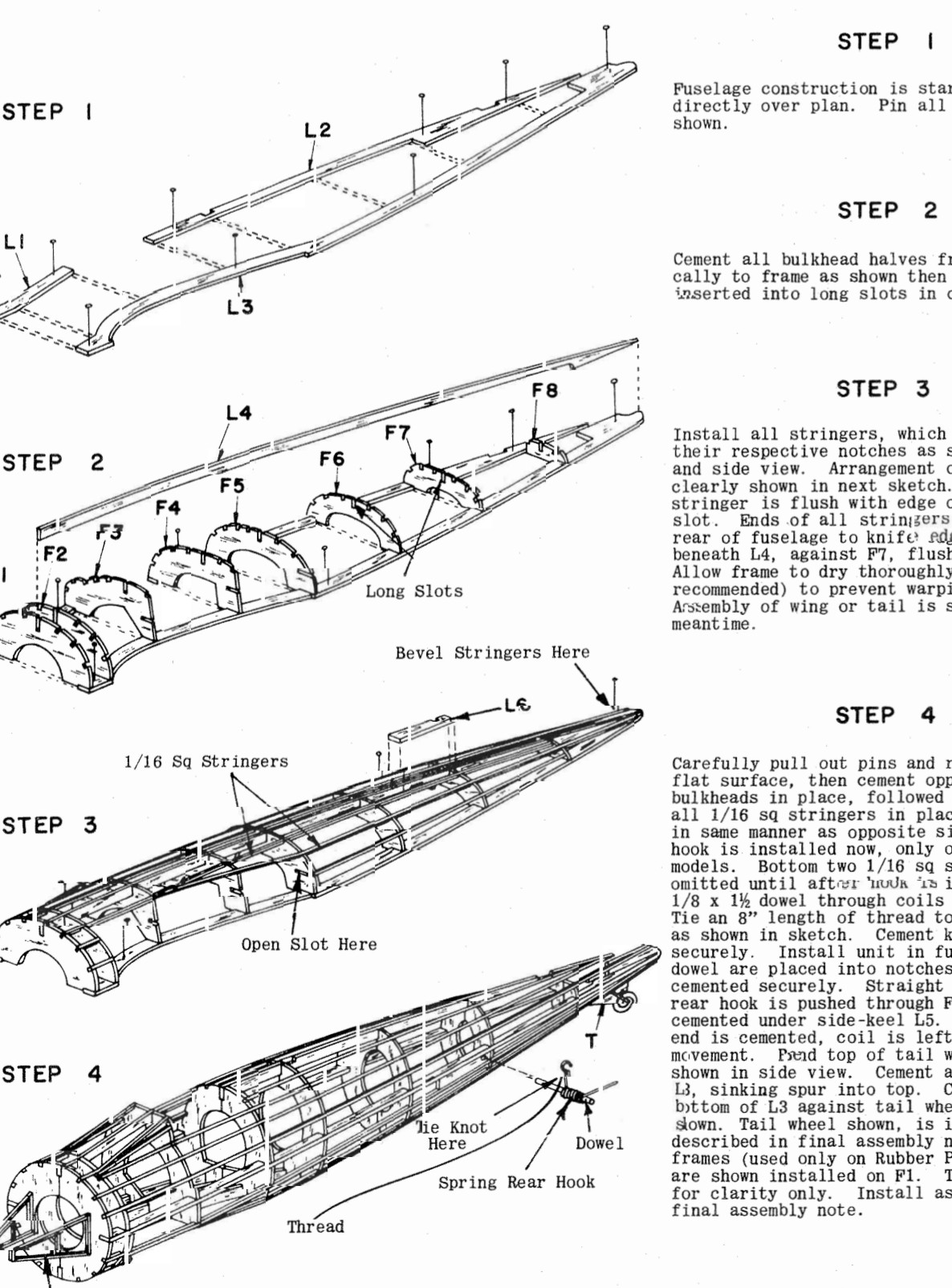

**STEP 1**  
Fuselage construction is started on flat surface directly over plan. Pin all L parts in place as shown.

**STEP 2**  
Cement all bulkhead halves from F1 to F8 vertically to frame as shown then add L4 which is inserted into long slots in center of bulkheads.

**STEP 3**  
Install all stringers, which are 1/16 sq into their respective notches as shown on sketches and side view. Arrangement of top stringers is clearly shown in next sketch. Bottom rear stringer is flush with edge of F5 leaving open slot. Ends of all stringers are beveled at rear of fuselage to knife edge. Cement L6 beneath L4, against F7, flush with surface. Allow frame to dry thoroughly (overnight recommended) to prevent warping or twisting. Assembly of wing or tail is started in the meantime.

**STEP 4**  
Carefully pull out pins and remove frame from flat surface, then cement opposite halves of bulkheads in place, followed by L4. Cement all 1/16 sq stringers in place, then add L6 in same manner as opposite side. Spring rear hook is installed now, only on rubber powered models. Bottom two 1/16 sq stringers may be omitted until after hook is installed. Insert 1/8 x 1/8 dowel through coils of rear hook. Tie an 8" length of thread to bottom of hook as shown in sketch. Cement knot to hook securely. Install unit in fuselage. Ends of dowel are placed into notches in L6's and cemented securely. Straight end of spring rear hook is pushed through F7 and securely cemented under side-keel L5. Only straight end is cemented, coil is left free for spring movement. Bend top of tail wheel gear as shown in side view. Cement against side of L3, sinking spur into top. Cement T to bottom of L3 against tail wheel gear as shown. Tail wheel shown, is installed as described in final assembly note. Cowl frames (used only on Rubber Powered models) are shown installed on F1. They are shown for clarity only. Install as described in final assembly note.

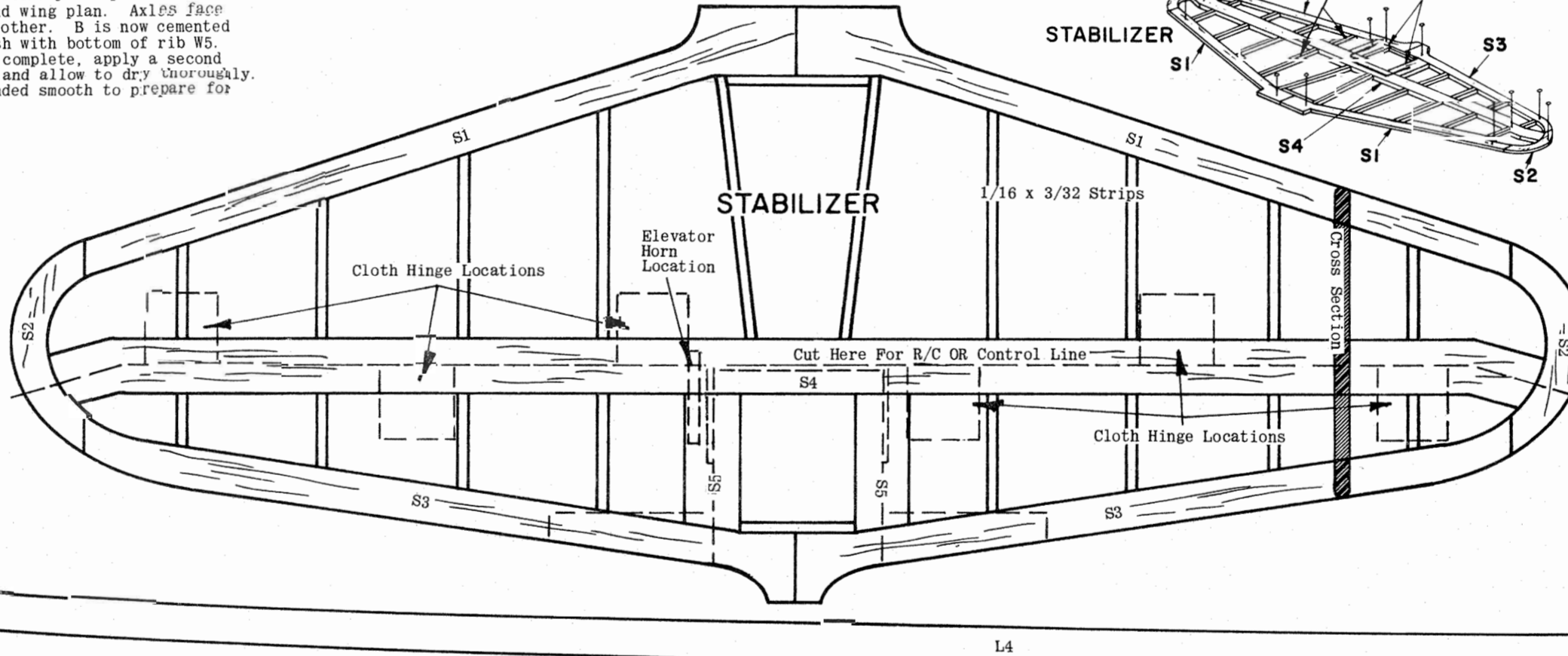

**DIE CUT PART NOTE**

All die cut parts used in construction are given full size either on full size plan or individual layout. This will enable you to duplicate any part should it become necessary for any reason. Die cut parts contained in sheet as furnished in kit are also available from the factory as replacements.

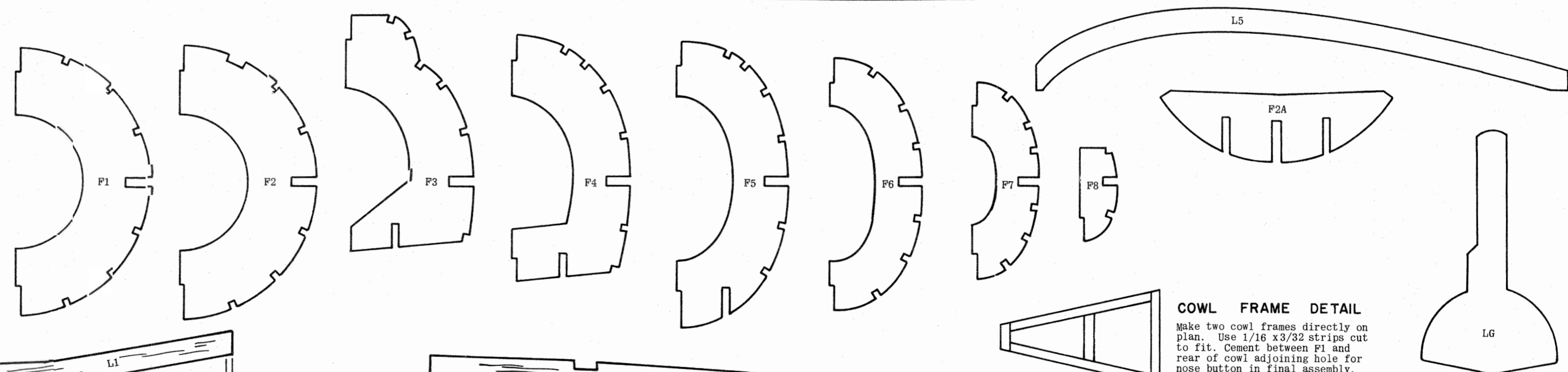

**FUSELAGE FRAME ASSEMBLY**

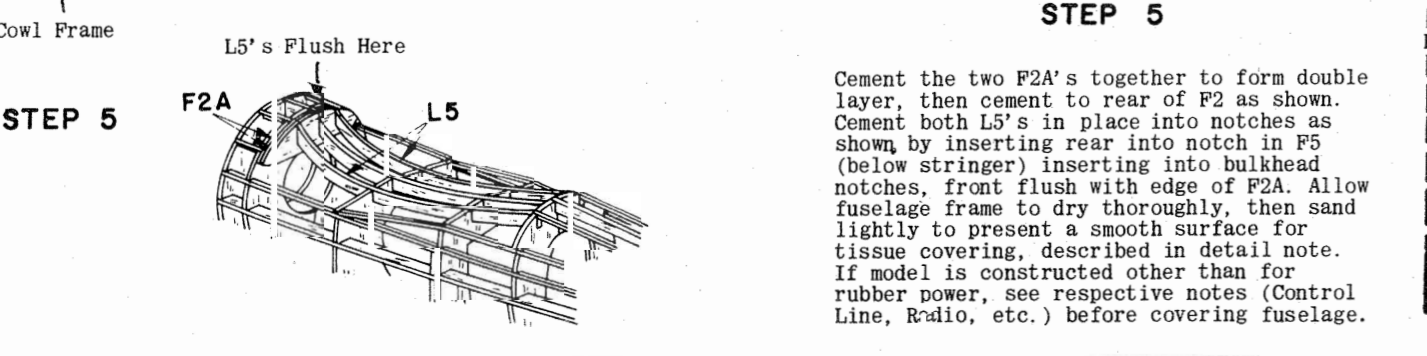

**STEP 5**  
Cement the two F2A's together to form double layer, then cement to rear of F2 as shown. Cement both L5's in place into notches as shown by inserting rear into notch in F3 (below stringer) inserting into bulkhead notches. Front flush with edge of F2A. Allow fuselage frame to dry thoroughly, then sand lightly to present a smooth surface for tissue covering, described in detail note. If model is constructed other than for rubber power, see respective notes (Control Line, Radio, etc.) before covering fuselage.

Slot here for R/C Torque Rod.