

Insert red wheel hubs firmly into rubber tires as shown above, seating into groove.

FINAL ASSEMBLY

Assemble and trim all plastic parts, see detail note. Cement cowl to F1. Cement stabilizer into slot between L2 and L3, against F10. Cement rudder to top of L2 and against rear of fuselage. Cement lower wing in place on bottom of fuselage, lining up W1's with L5's. Lower wing must be dry before proceeding. Trim out notches in all gussets in both wings. Prepare all plastic engine covers and exhausts as now assembled directly over side view. Round off 3/16 sq balsa provided for long exhaust stacks. Balsa provided for lightness. 3/16 dowl (not provided) may be used on engine powered models. Cut stacks to length, rounding both ends. Cut 8 pieces of 1/8 x 5/32 dowl cementing them between engine cover and exhaust stack in position shown. MAKE ONE EACH RIGHT AND LEFT! Paint black and cement in place. Outline windshield in black and cement in place. Outlines of scale cockpit instruments may be drawn on with India Ink. Slip rubber tires on wheel hubs. Place wheel on axle. Secure by bending up end of axle or with drop of cement or solder. Insert straight end of propeller shaft through rear of nose bearing. Slip on two washers provided and insert shaft through back of free wheeling propeller. Bend back about 1/4" of shaft as shown on side view. Tie double square knot in length of rubber. Wet rubber first to prevent fraying. Double up to make 2 loops, then insert rubber through bottom trap door and engage in rear hook. Slip down towards nose. Make hook on end of a piece of wire. Slip through hole in cowl and capture rubber on hook. Pull through cowl and engage prop shaft. Nose bearing fits into center hole in cowl. Your Royal Air Force Fighter Scout S.E.5a is now completed. See flight instructions before flying model. GOOD LUCK AND HAPPY LANDINGS!!!

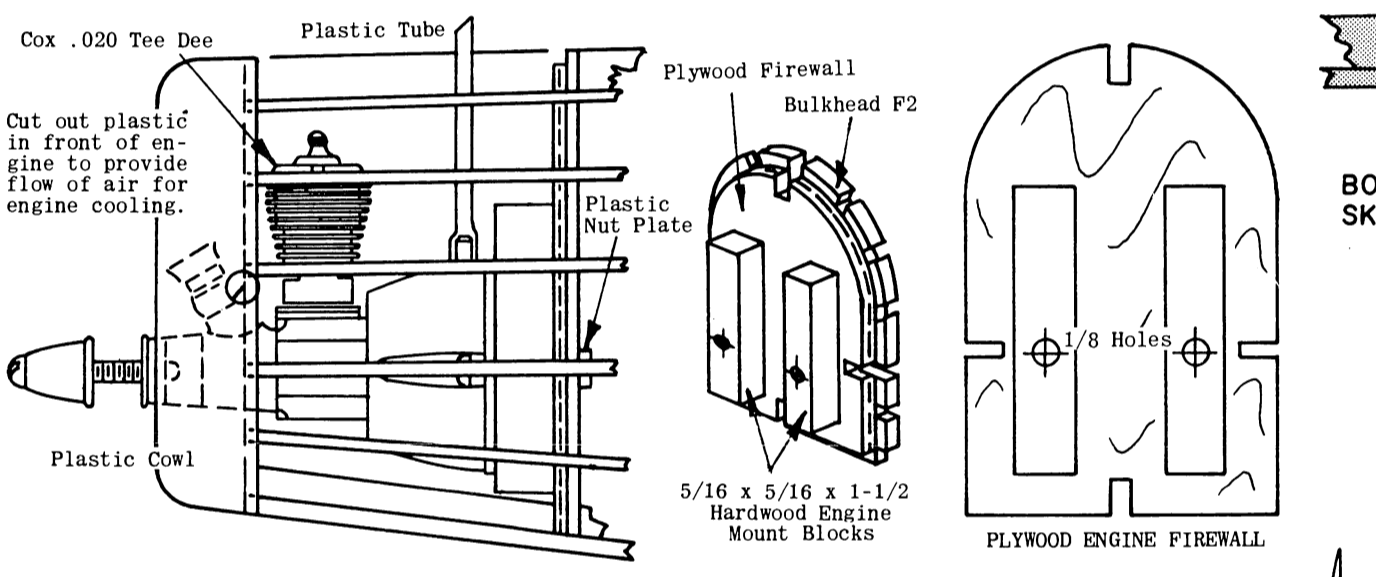

ENGINE INSTALLATION

Engine is used if model is being built for control line, free flight or radio. Engine and installation material not provided in kit. Drawing shows installation of Cox .020 Tee Dee engine, however, any other similar engine may be used. Front of model should be covered with 1/32 sheet balsa back to F6. Top is cut out for engine clearance. Obtain a piece of 1/16 plywood and cut engine fire wall, using full size drawing, drilling holes indicated. Cut two engine mount blocks 5/16 x 5/16 x 1-1/2 from hardwood. Cement them securely to plywood fire wall in position shown. When dry, drill 1/8 holes through blocks and fire wall. Mount engine to fire wall with #2 nuts and washers, tightening nuts securely. Cut plastic nut plates from molded sheet and securely cement to back of fire wall over nuts, drilling hole through so that bolts can protrude. Use cement generously. Nut plate keeps nuts from turning so that engine can be removed by just unscrewing bolts. When dry, remove engine. Securely cement fire wall to front of F2. Cut mold engine cowl from plastic sheet as described in detail note and fit over F1. Trim cowl to clear engine. Cowl is not installed until after model is painted, and engine is installed. Cowl is then cemented or held in place with small wood screws. If it becomes necessary to remove engine for any reason, break cement joint of cowl. Engine is then re-installed and cowl is cemented or screwed back in position. Add a 1-3/8" length of 1/16 I.D. plastic tubing to fuel tank fill and overflow tubes. Cut top of tubing at angle facing forward for easy assembly of air stream. Make needle valve extension by forcing a length of 1/8 I.D. plastic tubing over head of needle valve. Force a length of 1/8 dowl into end of tubing. Dowl should protrude at least 1/2" past cowl.

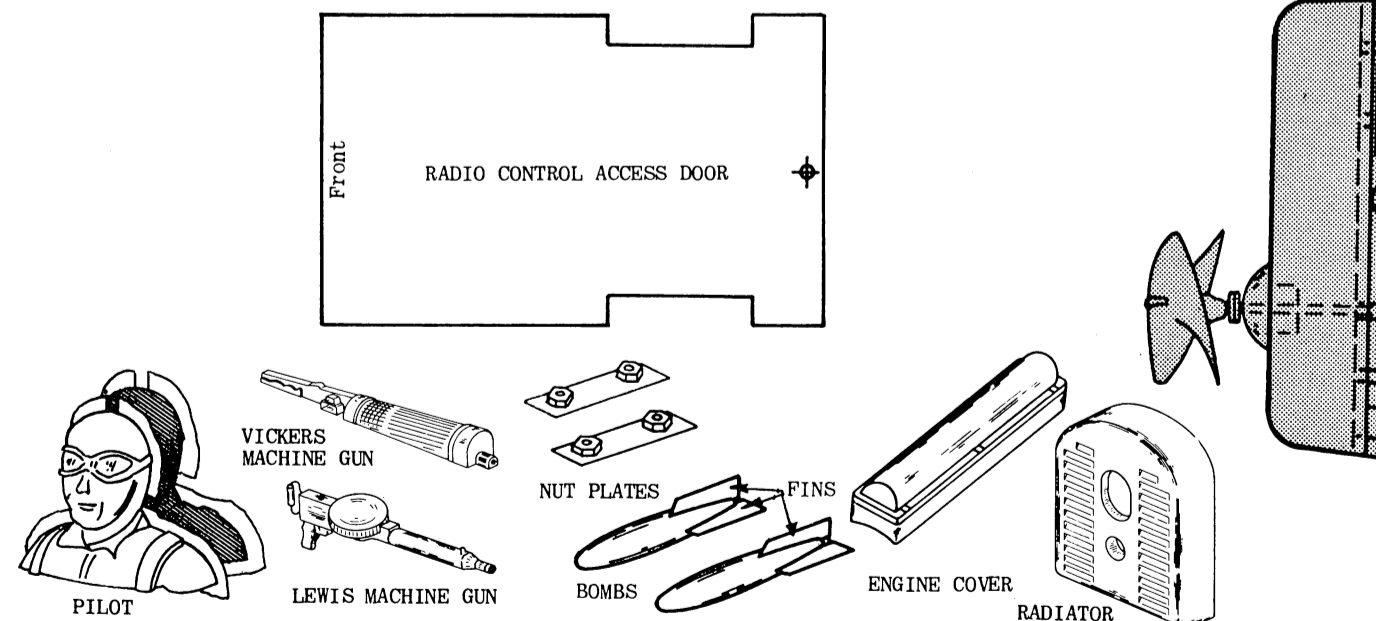
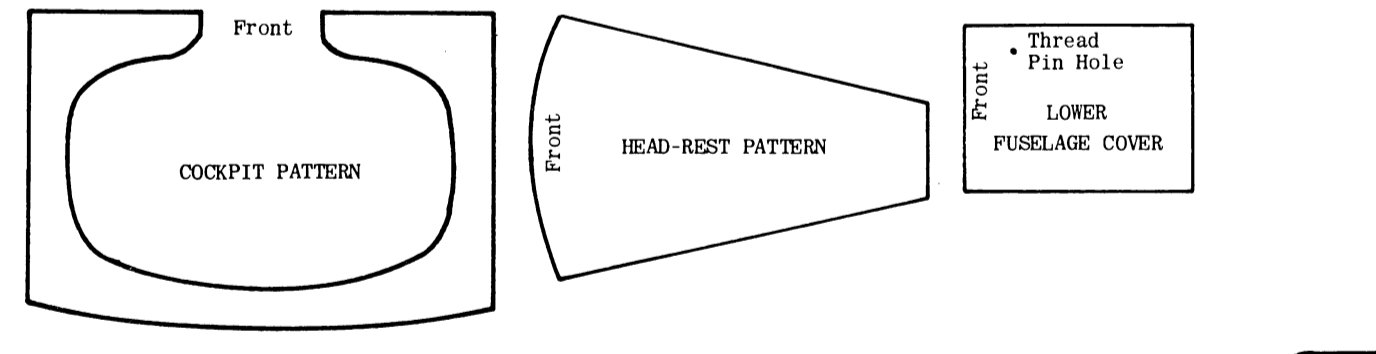

For best results, follow instructions carefully. COWL: Cut from sheet leaving about 1/16 of material for trim. Excess material may be trimmed with knife or razor blade and then sanded with fine sandpaper. Cowl is placed on bulkhead F1 for support while sanding. LEWIS MACHINE GUN: Leave about 1/8 excess material when cutting halves from sheet. Carefully trim out slots about 1/8" wide on top, bottom and ends, right to the edge of the machine gun as shown. This will permit accurate assembly. Cement halves together, lining up carefully at slots. Use cement sparingly however, since excessive use will distort the plastic. After assembly, allow to dry thoroughly then trim and sand off smooth. Complete Lewis gun mounting as described in detail note. VICKERS MACHINE GUN: Cut from sheet and trim carefully. Paint dark grey and cement to fuselage as shown on side view. PILOT: Cut halves from plastic sheet, leaving about 1/8 material. Cut 1/8 slots on all four sides as shown. Trim carefully cement together in same manner as the Machine Guns. BOMBS: Cut out of sheet in same manner as pilot, making notches in excess material for assembly. Cement halves together. When thoroughly dry, trim and sand smooth, then cut out 4 bomb fins each which are scribed on plastic sheet. Cement fins to ends of bomb at right angles, along seams as shown. Make two pin holes in each bomb and cement "U" shaped guide (see Bomb Release Detail Sketch #2) securely in place. NUT PLATES: Cut from sheet right along trim line and install as described in Engine Installation. ENGINE COVERS: Cut from sheet and trim as shown above. PAINTING: Regular plastic model paint or enamel can be used. Model airplane dope can be used only if applied in LIGHT spray coats, allowing paint to dry thoroughly between coats. Excessive use of dope may deform plastic. Parts may be used red as provided or if painting parts a lighter color than red, apply a light coat of silver, followed by a light coat of white before painting final color. Darker paints may be applied directly to red plastic. When cementing parts in place on model, use light coats of cement applied sparingly. If necessary, use more than one coat, but DO NOT APPLY A THICK COAT AT ANY TIME.

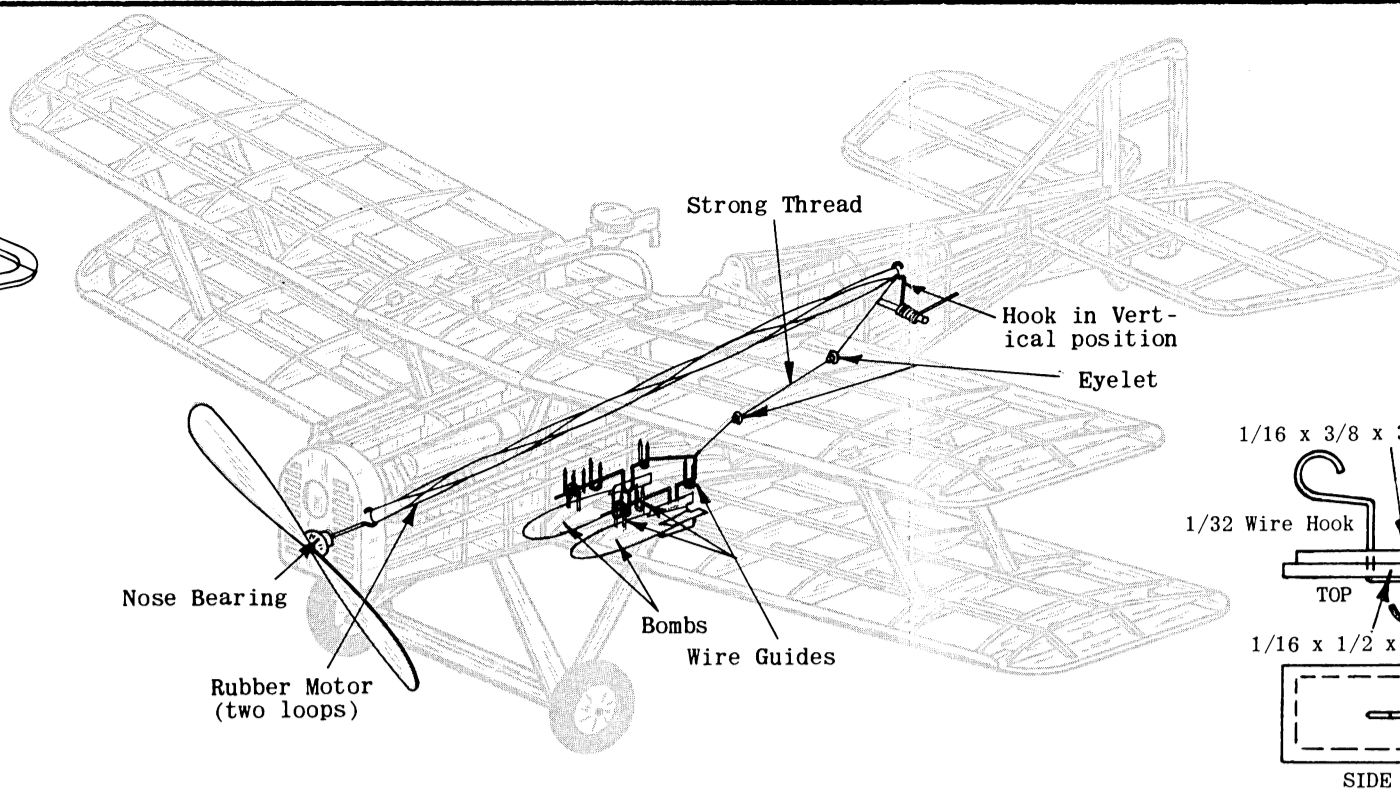

AUTOMATIC BOMB RELEASE

Automatic bomb dropping in flight operates on rubber powered models only, using spring rear hook. (Bombs can be released using a 3rd line on control line models or with escapement on R/C models). Installation is simple and action is positive, if directions are followed carefully. Make hole and cement eyelet to bulkheads F7 and F8, to right of keel L3. Bend ten "U" shaped guides from straight pins, using pattern provided. Bend bomb release pin from 1/32 wire, using full size pattern. Cement the 8 guides in place on each side of wing as shown in bomb release sketch #1, and full size drawing. Assemble bombs as described in Plastic Parts Detail and cement wire guides in place as shown. Cover bottom of fuselage on right side between F6 & F7 with stiff paper. Insert thread from rear hook through eyelets and pin hole made in stiff paper as shown. Insert bomb release pin through wire guides, then securely tie thread to hook, with bomb release pin handle against rear wire guides as shown. Thread must be snug when release pin is in this position. Coat knot on release pin with cement. This completes mechanism. To operate: Wind rubber motor. This will pull rear hook forward to a horizontal position, loosening thread. This now permits release pin to be slid forward, through front wire guides to position shown in Sketch #2; while at the same time engaging bombs through their wire guides. Push pin forward until line is snug. Mechanism should now look exactly as drawn in Bomb Sketch #2. Bombs are now loaded. Model is now released, and towards the end of flight when motor unwinds, rear hook pulls back into vertical position. This tightens the lines, pulling release pin back past second guide, which releases and drops bombs. GOOD HUNTING!!!

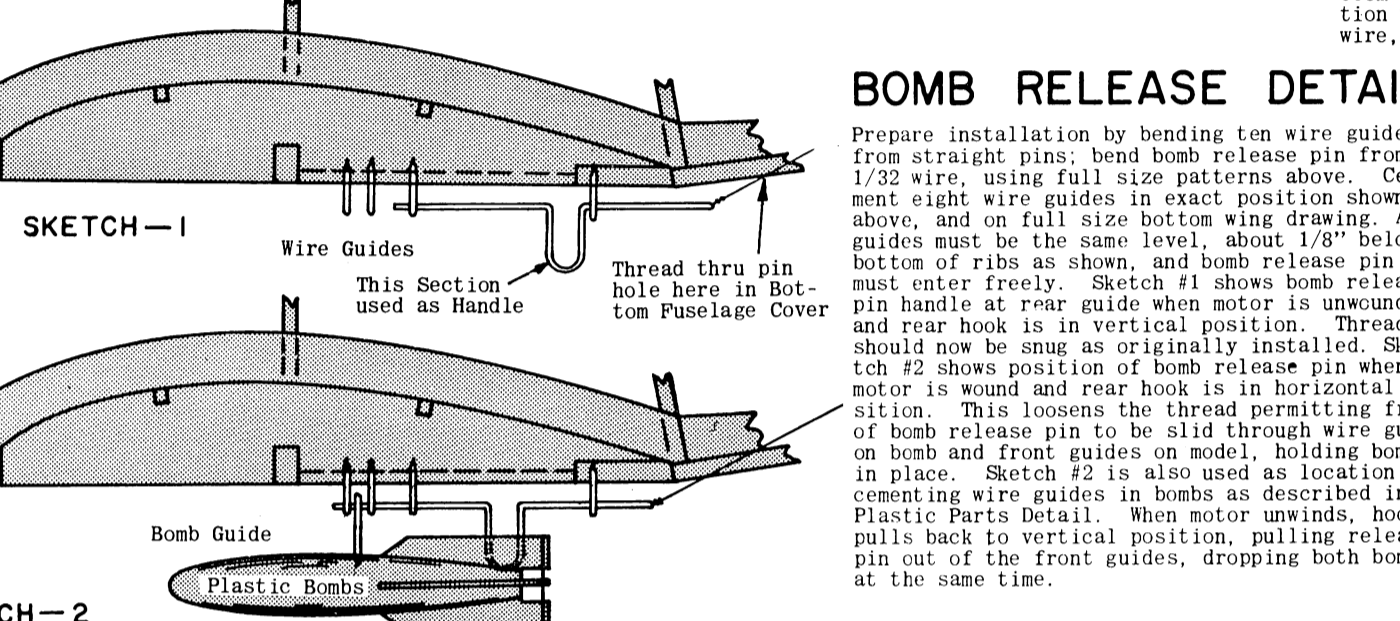

BOMB RELEASE DETAIL

Prepare installation by bending ten wire guides from straight pins; bend bomb release pin from 1/32 wire, using full size patterns above. Cement eight wire guides in exact position shown above, and on full size bottom wing drawing. All guides must be the same level, about 1/8" below bottom of ribs as shown, and bomb release pin must enter freely. Sketch #1 shows bomb release pin handle at rear guide when motor is used, and rear hook is in vertical position. Thread should now be snug as originally installed. Sketch #2 shows position of bomb release pin when motor is wound and rear hook is in horizontal position. This loosens the thread permitting front of bomb release pin to be slid through wire guides on bomb and front guides on model. Release pin in place. Sketch #2 is also used as location for cementing wire guides in bombs as described in Plastic Parts Detail. When motor unwinds, hook pulls back to vertical position, pulling release pin out of the front guides, dropping both bombs at the same time.

S.E.5a SPECIFICATIONS AND COLOR SCHEME

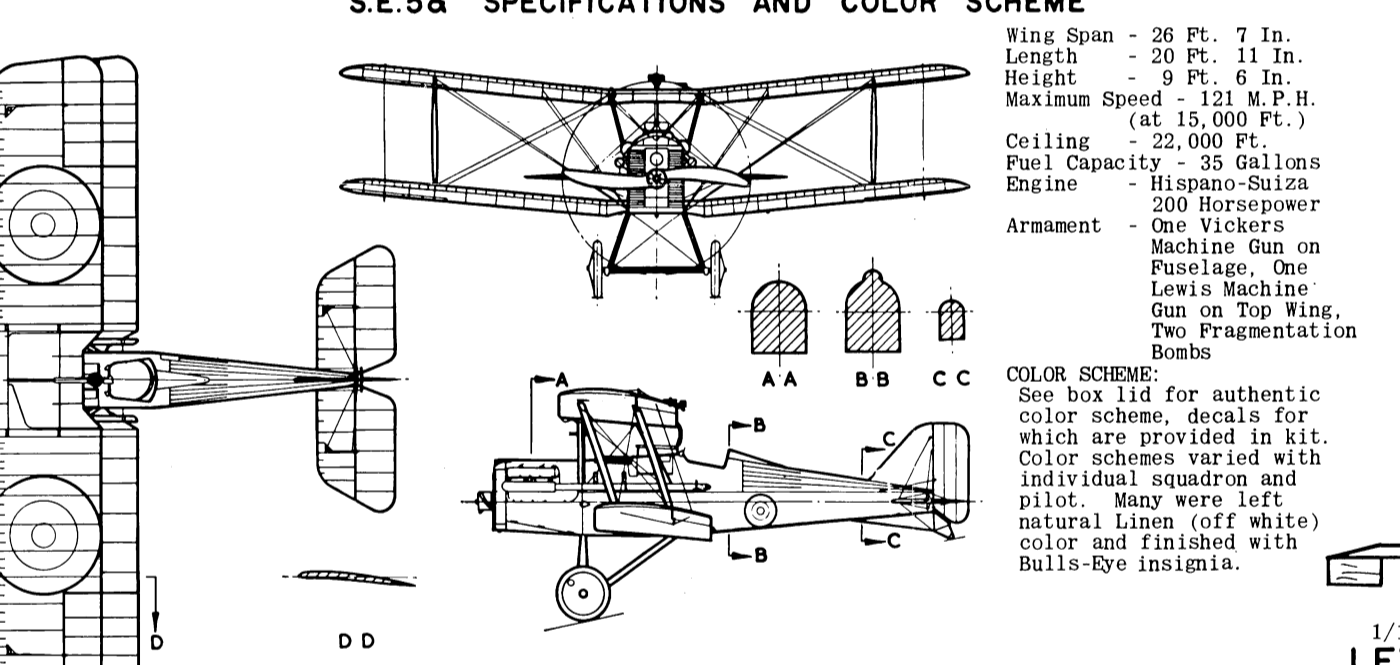

Wing Span - 26 Ft. 7 In.
Length - 20 Ft. 11 In.
Height - 9 Ft. 6 In.
Maximum Speed - 121 M.P.H. (at 15,000 Ft.)
Ceiling - 22,000 Ft.
Fuel Capacity - 35 Gallons
Engine - Hispano-Suiza
200 Horsepower
Armament - One Vickers Machine Gun on Fuselage, One Lewis Machine Gun on Top Wing, Two Fragmentation Bombs

COLOR SCHEME:
See box lid for authentic color scheme, decals for which are provided in kit. Color schemes varied with individual squadron and pilot. Many were left natural (liver off white) color and finished with Bulls-Eye insignia.

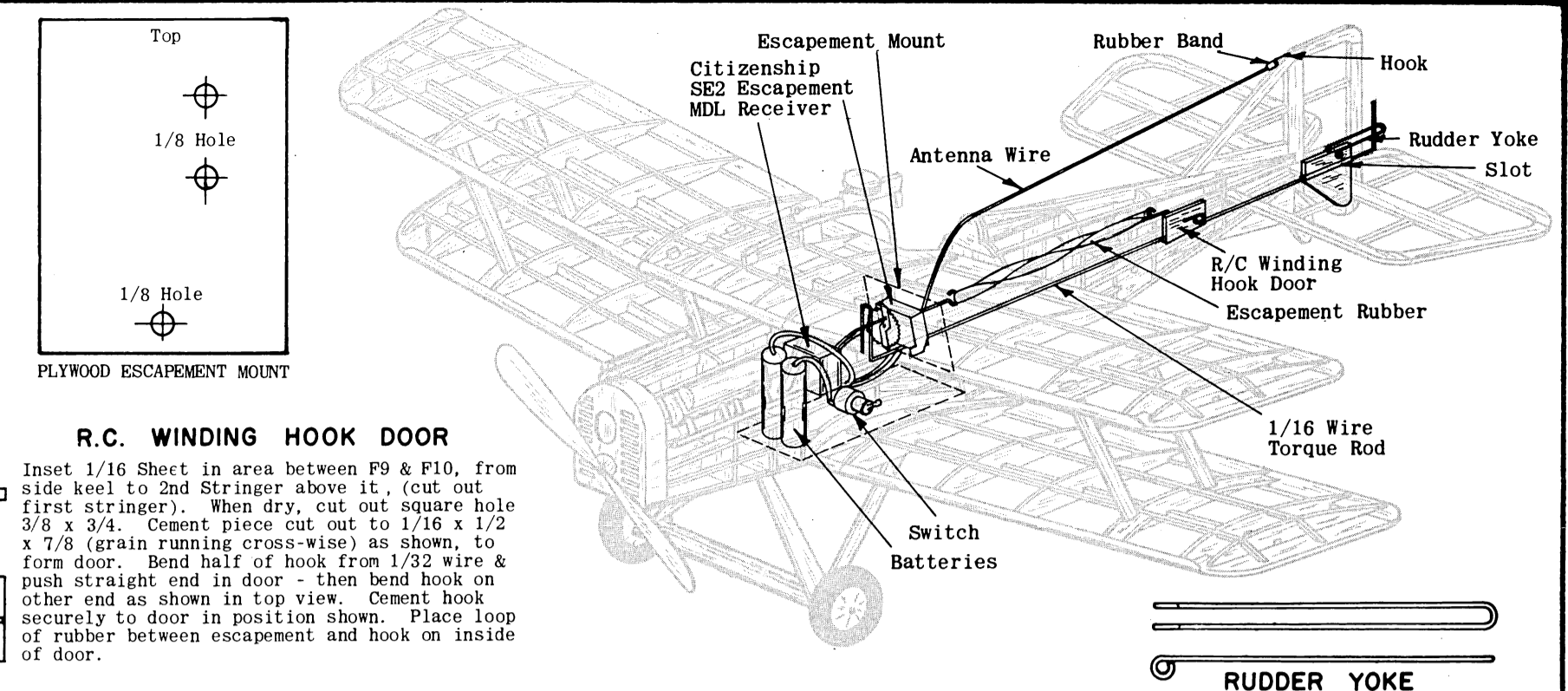

RADIO CONTROL INSTALLATION

Test models used, and drawing shows, Citizen-Ship MDL Receiver, SE2 Escapement, used with SPX Transmitter. This equipment and other material necessary is not provided in kit. Radio is installed after lower wing is cemented in place as described in Final Assembly. Access to R/C equipment is through 1/16 plywood (not provided) door made using full size drawing above. Door fits between outer ribs W1. Cut out center rib W1 and fuselage keel above it as well as 1/16 sq spars. Trim E's to fit door. Recess center spar 1/16 to act as door stop, keeping door flush. Cement 1/8 x 3/16 x 1-5/8 hardwood strip, across bottom of E's to act as door stop. Cement cloth tape to front end, half over door, for hinge. Rear of door is held with small wood screw into hardwood strip. Cut rudder apart at location shown by dotted lines. Fill in lower section of rudder with scrap balsa as shown, then cut off top of rudder. Cement bottom section back in place and assemble top section with cloth hinges. Bend wire yoke from 1/32 wire, install on rudder with 2/96 nut and bolt.

Cut escapement base from 1/16 plywood and mount escapement, then cement to front of bulkhead F6 as shown. Cut a 3/32 slot in rear of fuselage & thru lower section of rudder for torque rod. Using a length of 1/16 wire at least 16" long, insert through hole, then bend U in front of wire according to R/C manufacturer's instructions and as shown above. Pull back and engage U in escapement. Bend rear at right angle as shown, to engage in yoke. Cut off wire 3/4" above yoke. Raising and lowering yoke will increase or decrease the amount of rudder movement. Wire all radio equipment together in accordance with R/C manufacturer's instructions. Batteries are stored between F4 and F5. After they have been soldered, line compartment with foam rubber, then insert batteries. Wrap receiver with foam rubber and place in fuselage between F4 and F5. Close radio mount door and secure with screw. Bend small wire hook for antenna attachment and cement to front of rudder. Bring antenna out of cockpit and fasten to hook with rubber band as shown.

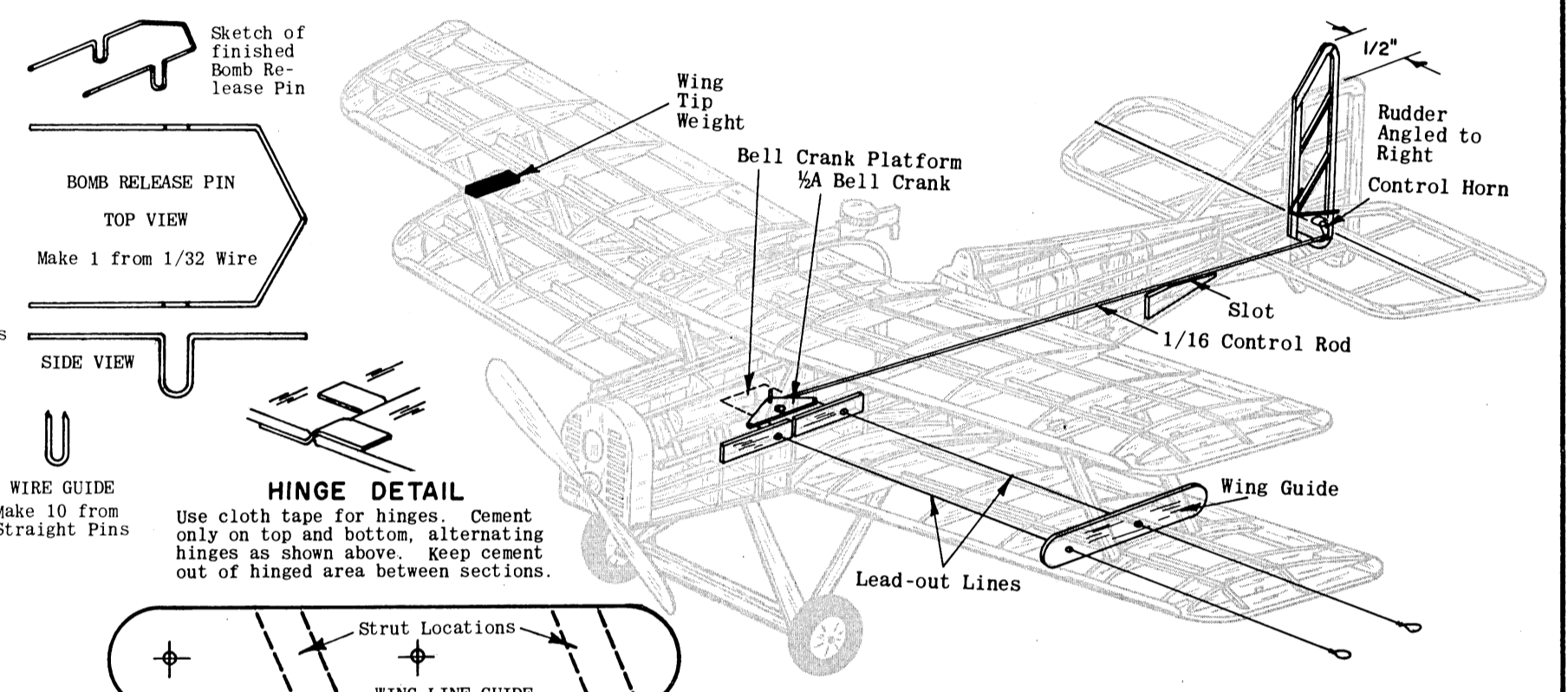

CONTROL LINE INSTALLATION

Materials required are not provided in kit. Make bell crank platform from 1/16 plywood using full size plan above. Securely cement across L4's against rear of F4. Fill in area between F4 and F6, from side keel L4 to stringer above it, with scrap 1/16 sheet balsa; flush with outside of frame. Fill in area from F9 to F10 between L4 and stringer above it in same manner. Cut 1/8 slot in rear for control rod as shown. Cut two 18" lengths of lead-out lines and fasten them to bell crank. Push rod is 1/16 wire at least 13" long. Make a right angle bend at one end. Place in fuselage, insert in bell crank, and mount assembly to plywood platform as described in instructions that come with bell crank. Cut stabilizer in half through wide main spar as indicated by dotted lines. Round edges and install control horn at location shown on drawing, then join together with cloth hinges shown. Bend "U" shape elevator joiner from wire. Make hole for joiner in rudder - then cement spurs to both elevators in position shown. Elevators now move as one unit. Cement stabilizer horizontally into slot between L2 and L3, against F10. Tape elevators in neutral position (in line with stabilizer, neither up or down). Make right angle bend at rear end.

LEWIS GUN INSTALLATION

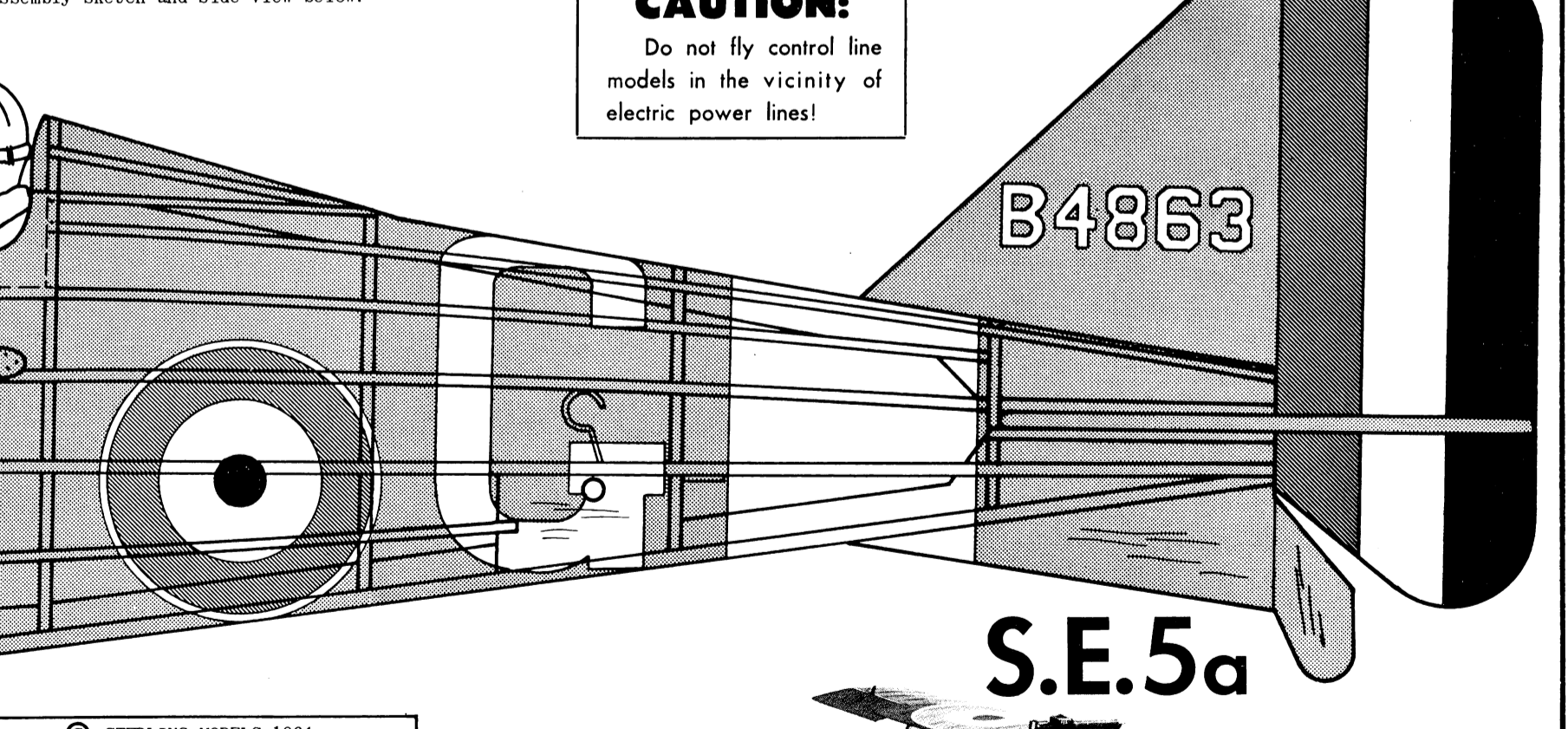

Assemble halves of Lewis Machine Gun as described in Plastic Parts Detail. Make handle by cementing two short lengths of wire, followed by a length of reed to end of machine gun as shown. Push short length of wire in place for trigger. Bend trigger guard from wire and cement in place. Reed provided for gun track is dipped in water, pinned to plan and allowed to dry so it will assume shape. Cut the two mounts from 1/16 scrap balsa and cement to reed on plan. When dry, assembly is cemented to top wing as shown (exploded) on final assembly sketch and side view below.

CAUTION:

Do not fly control line models in the vicinity of electric power lines!



During World War I, this fighting scout of the Royal Air Force wreaked havoc on the Imperial German Air Force. This gun plane was also used to knock out enemy airfields and rail centers. Our authentic scale model DROPS its twin BOMBS automatically, in flight.

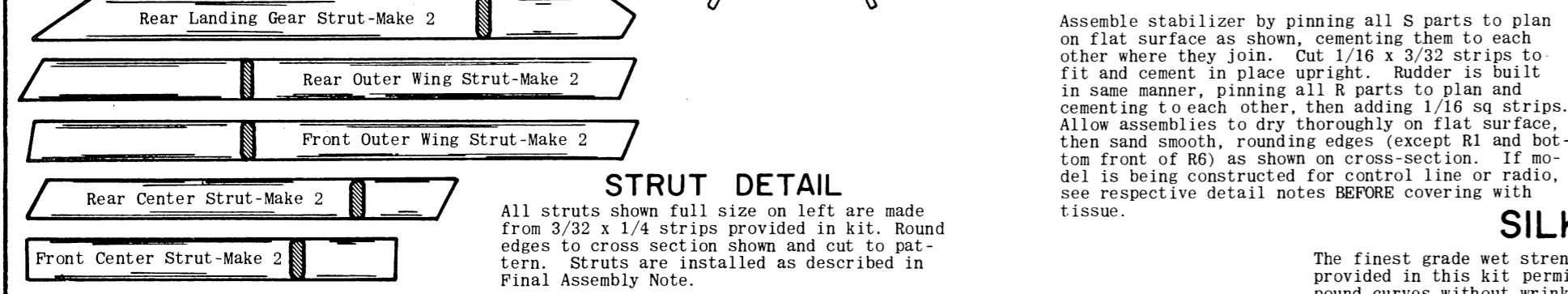
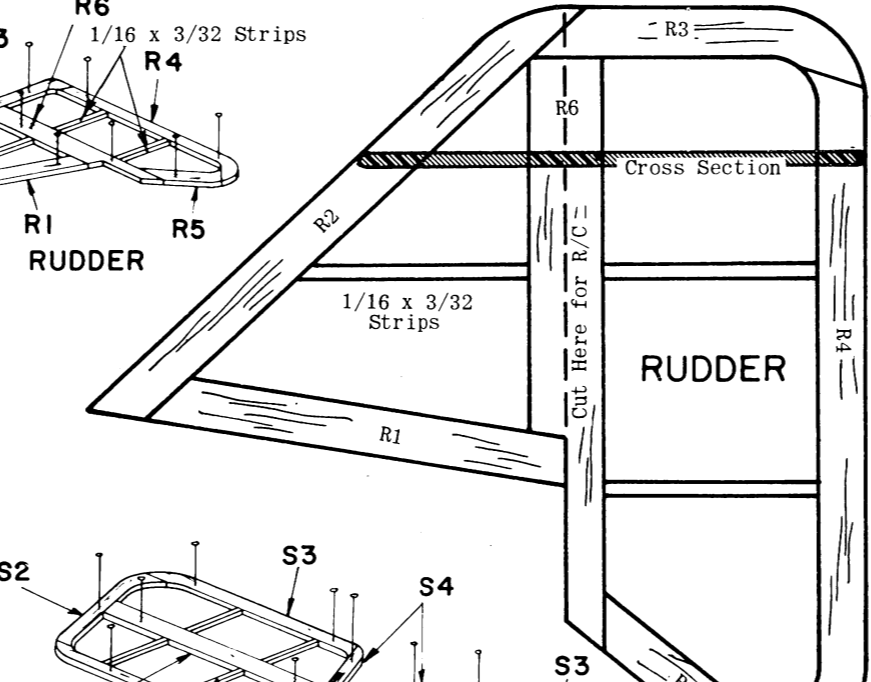
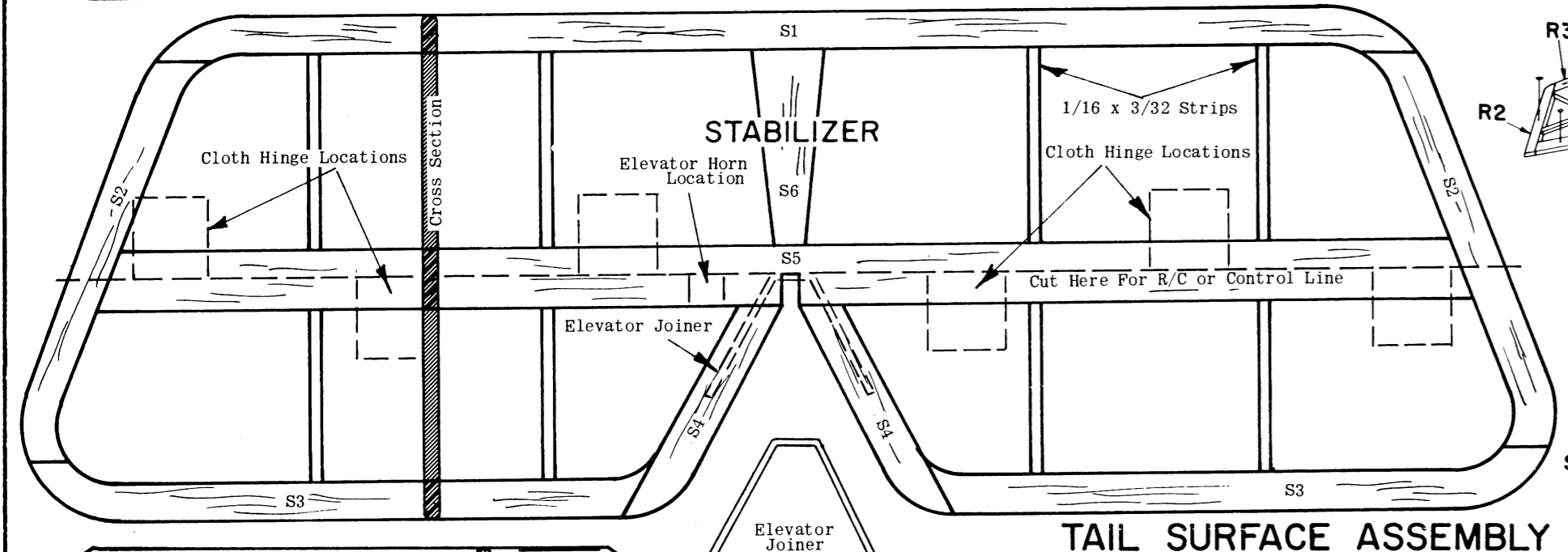
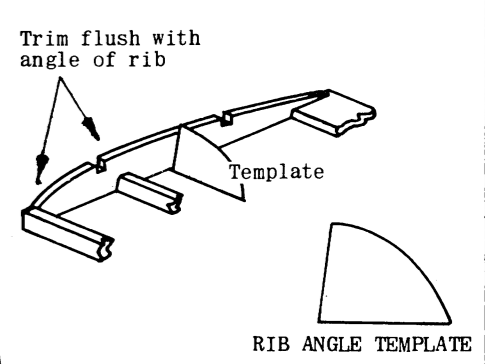
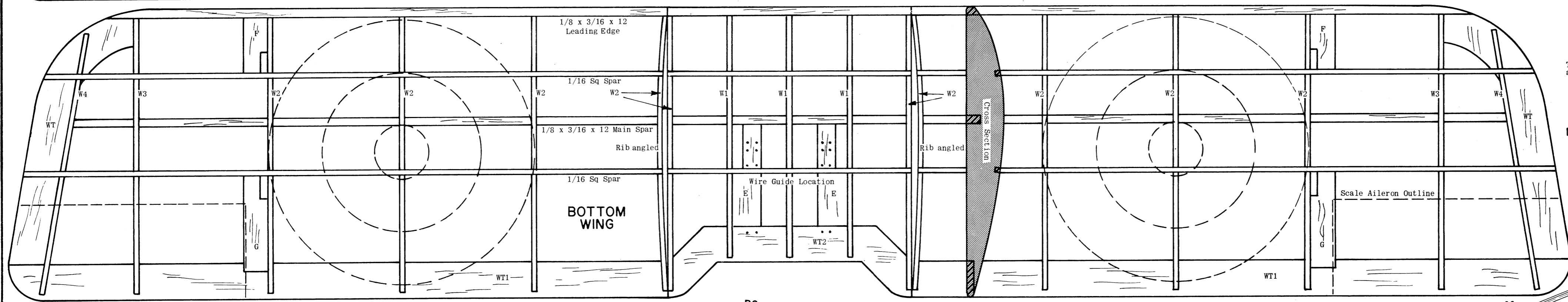
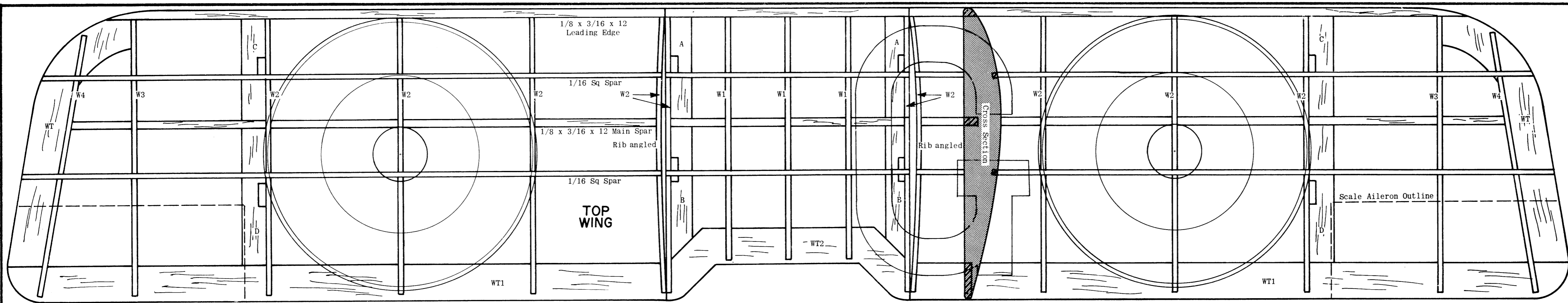
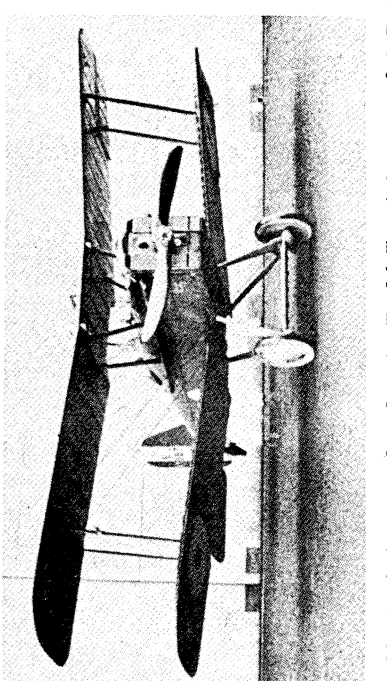

FUSELAGE ASSEMBLY

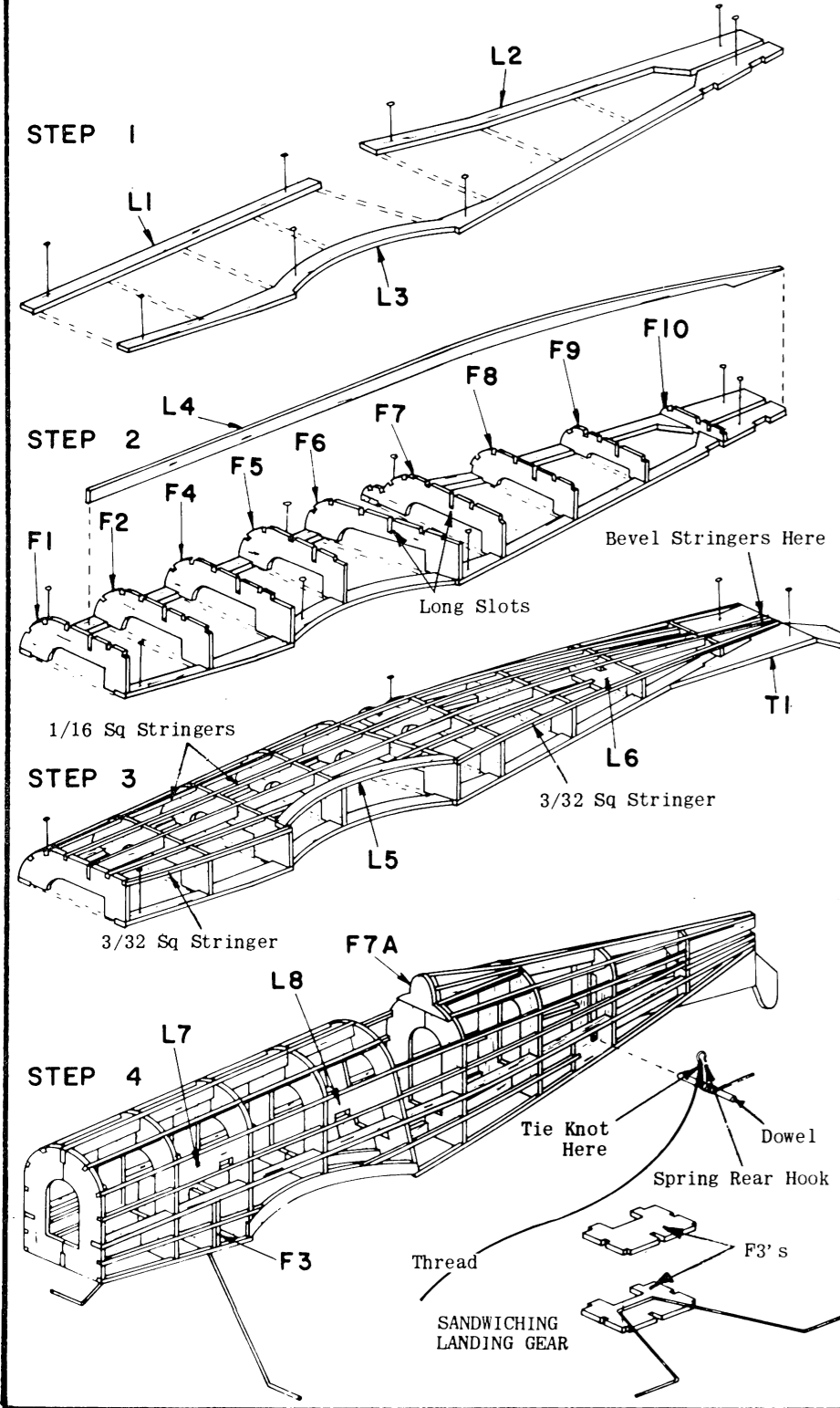

STEP 1
Fuselage construction is started on flat surface directly over plan. Pin L parts in place as shown.

STEP 2
Cement all bulkhead halves from F1 to F10, except F3 which is added in next step vertically in place as shown, then add L4, which is inserted into long slots in center of bulkheads.

STEP 3
Pin and cement side keel L5 into notches in corners from F5 to F6. Note 3/32 space left for corner stringer. Cement 3/32 sq stringer into lower corner of bulkheads from F1 to F4, and from F6 to rear. Moistening stringer with water will help it bend. Bevel end to fit. Cement L6 between L4 and stringer, against F9 as shown. Cement the rest of the stringers which are 1/16 sq. into their respective notches, beveling ends to knife edge at rear. Any stringers not visible are clearly seen in next sketch. Cement T1 and T in place as shown. It is recommended that assembly be permitted to dry over night to prevent warping or twisting. Assembly of wing or tail surfaces can be started in the meantime.

STEP 4
Carefully pull out pins and remove frame from flat surface. Cement opposite halves of bulkheads in place, then add L4. Landing gear provided in kit is now installed. In the event that model is to be gas engine powered, it is recommended that you obtain a piece of 1/16 dia. music wire and bend a new landing gear to exact shape of one provided in kit. Installation of both are similar, being sandwiched between F3's as shown in detail sketch. Use cement generously when cementing unit in fuselage at location shown in sketch and side view - install stringers and L6 in same manner as opposite side, then add L7's, L8's and F7A. Install spring rear hook (omit on gas powered models) by inserting 1/8 dowel through coils of rear hook. Securely tie and cement a 10" length of thread to hook at location shown, then insert and cement ends of dowel between L6's. Push straight end of spring rear hook thru left side of bulkhead F9 beneath side keel L4 and cement securely in place. Only straight end of hook is fastened, leaving coil of hook free for spring movement. Allow fuselage frame to dry thoroughly, then sand lightly to present a smooth surface for tissue covering described in detail note. See respective notes for R/C, Control Line, etc.

SILKSPAN TISSUE COVERING

The finest grade wet strength silkspan tissue provided in this kit permits covering of compound curves without wrinkling, when moistened with water before applying to frame. Tissue shrinks when dry, to a tight smooth surface. Follow directions for a smoothly covered warp-free flying model. Use clear dope to attach tissue as follows: Apply a light coat to the outside edges of area to be covered and allow it to dry. Cut tissue to shape needed, plus 1/4" over-size. Place tissue on flat surface and dampen with moistened cloth by dabbing. Apply a second coat of clear dope then place moistened tissue on frame. Pull tissue gently with fingers, working out all wrinkles. WHEN COVERING WINGS AND TAIL SURFACES, PIN FRAMEWORK TO FLAT SURFACE TO PREVENT WARPS AS TISSUE DRIES. Cut out any wrinkled areas (bound by nearest framework) and re-cover. Apply 2 or 3 coats of clear dope, cut 50/50 with thinner, to wings and tail surfaces before assembling. Warts can be removed by holding over steam from boiling kettle, and twisting gently in opposite direction. Check again when cool.

TOP WING ASSEMBLY

STEP 1
Build wings on flat surface directly on plan. Pin all WT parts in place, cementing to each other where they join, except at center joints. Using 1/8 x 3/16 x 12, cut main spar comprising of two outer spars and center section, to proper length. Pin in place upright, cementing to WT's. 1/8 x 3/16 x 12 is also used for leading edge. Cut three sections in same manner and pin in place in upright position, cementing to front of WT's.

STEP 2
Ribs W1's, W2's, W3's and W4's are now cemented in place. All ribs are vertical except ribs W2 at joint which are cemented in place at angle as shown, using rib angle template (see detail note). This provides for dihedral angle shown and described in next step. Cement strut Gussets A and B to inside of center joint rib W2's as shown on sketch and full size plan. Do likewise with Gussets C and D to outside of outer ribs W2. Cement 1/16 sq spars into notches along top of ribs. Bevel ends of 1/16 sq to fit at tip as shown. Allow frame to dry thoroughly before removing from flat surface.

STEP 3
Pull out pins carefully and remove frame from flat surface. Separate sections and trim and sand leading edge to shape shown on wing cross-section. Round off tips and trailing edge as shown, to blend smoothly into each other. Trim off leading edge, spars and trailing edge flush to angle of ribs W2, then cement sections together on flat surface, blocking up each side 1-1/8 at tip rib as shown. Measurement must be the same at leading and trailing edge so that the wing is not warped. Center section should be pinned or weighted to keep flat on surface. Use cement generously and allow to dry thoroughly. When dry, sand frame smooth to prepare for tissue covering.

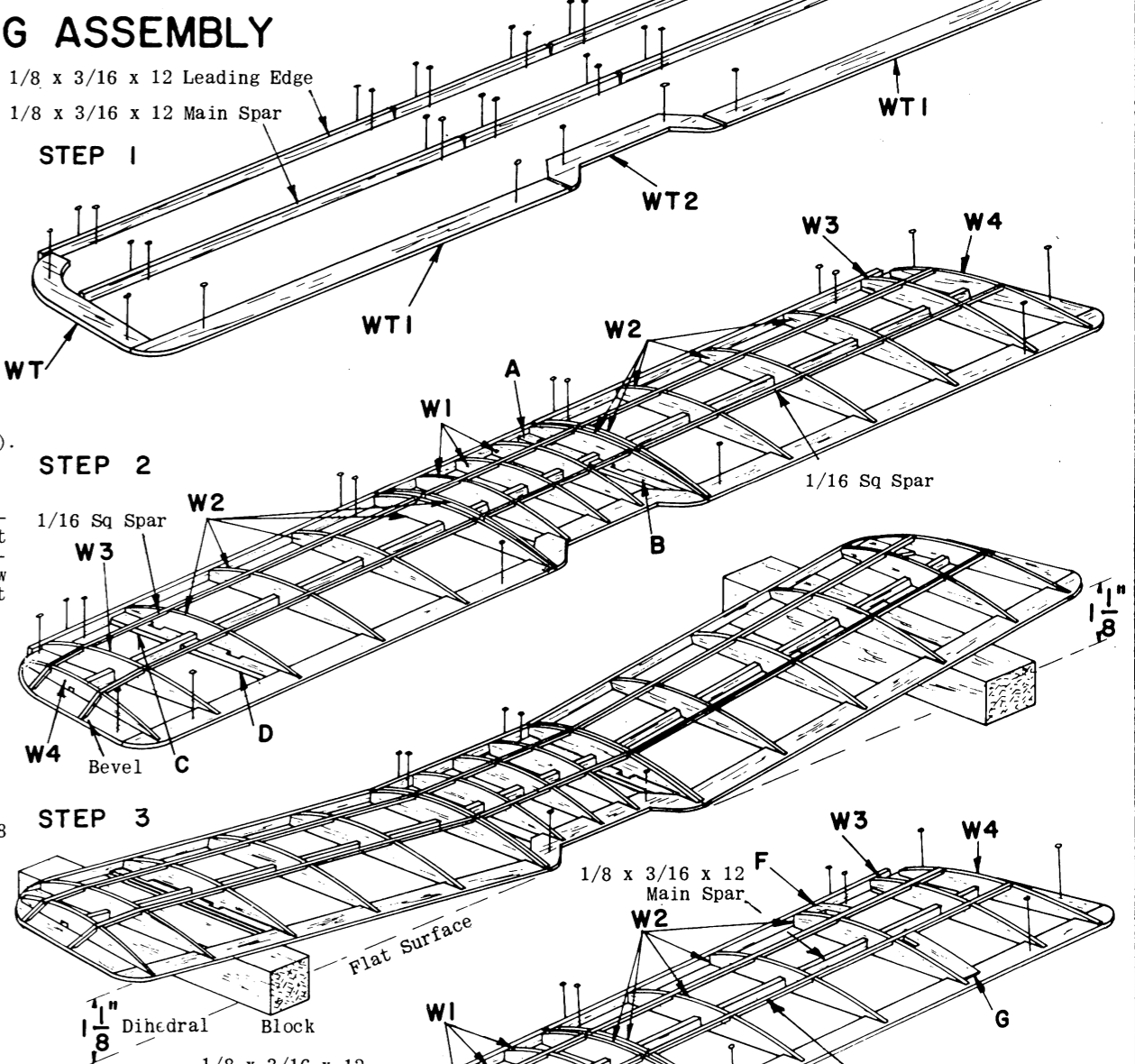

BOTTOM WING ASSEMBLY

Bottom wing is built same as top wing, only difference is installation of Gussets E, which are cemented flush with bottom outer ribs W1 as shown on sketch and full size wing plan. Gussets F and G are cemented FLUSH WITH TOP of outer ribs W2.

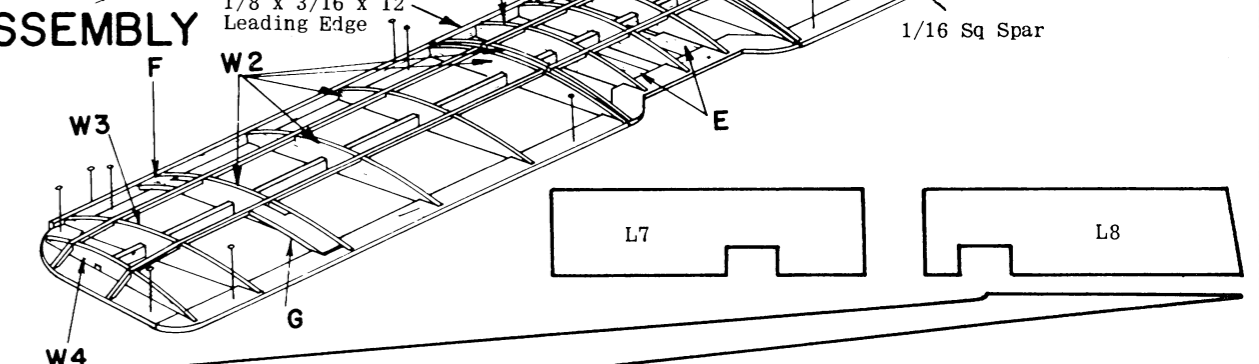

DIE CUT PART NOTE

Die cut parts used are given full size on plan or individual layout. This enables you to duplicate any part, for any reason. Die cut parts in sheet as in kit are available from factory as replacements.

