

# FUSELAGE ASSEMBLY

**1** FIRST READ INTRODUCTORY NOTE in separate Instruction Booklet. Carefully remove parts from Die-cut Sheets. It is suggested that you remove parts only as they are used to prevent lost pieces. When Gluing Parts, you must allow Glue to Dry thoroughly before continuing with that Part, otherwise as Glue continues to dry Parts will be pulled out of line.

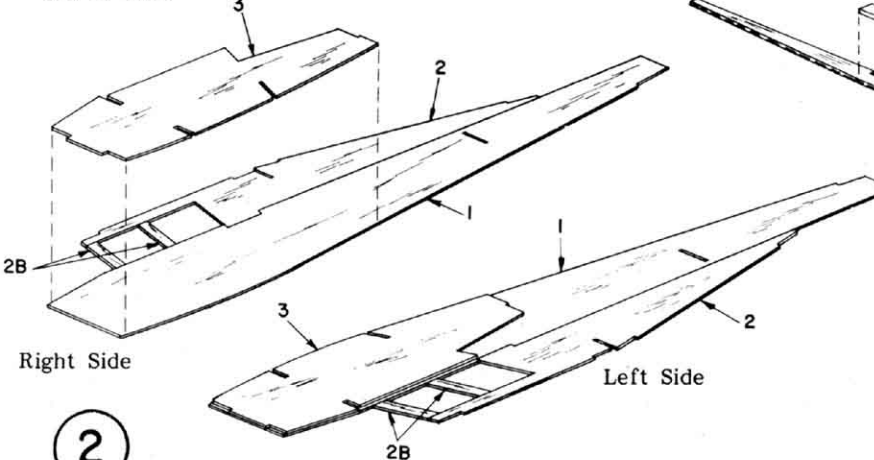
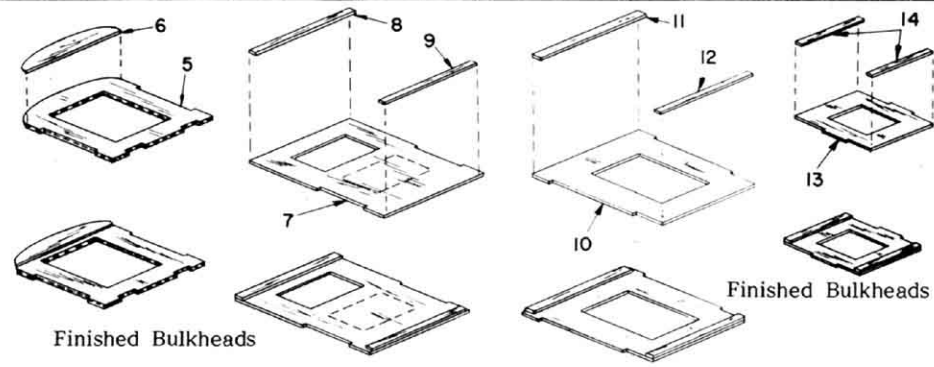

**2** Build a RIGHT and LEFT hand body (Fuselage) Side as shown using parts #1, #2, #2B and #3. Note that part #3 is Flush with Front and Top of Side but leaves a 1/16" space along Bottom and in Cabin area.

**3** Carefully Glue the Braces #8 and #9 to Fuselage Former (Bulkhead) #7 as shown. Note that #8 is flush with Edges and #9 leaves 1/16" space on each Side. If model is being built for Rubber or Control Line Flying cut out creased section of #7. Glue Braces #11 and #12 to Bulkhead #10 in same manner - #12 Flush and 1/16" space on each side of #11. Glue Braces #14 to Bulkhead #13. Glue #6 to Top of #5. Glue #27 to #29.

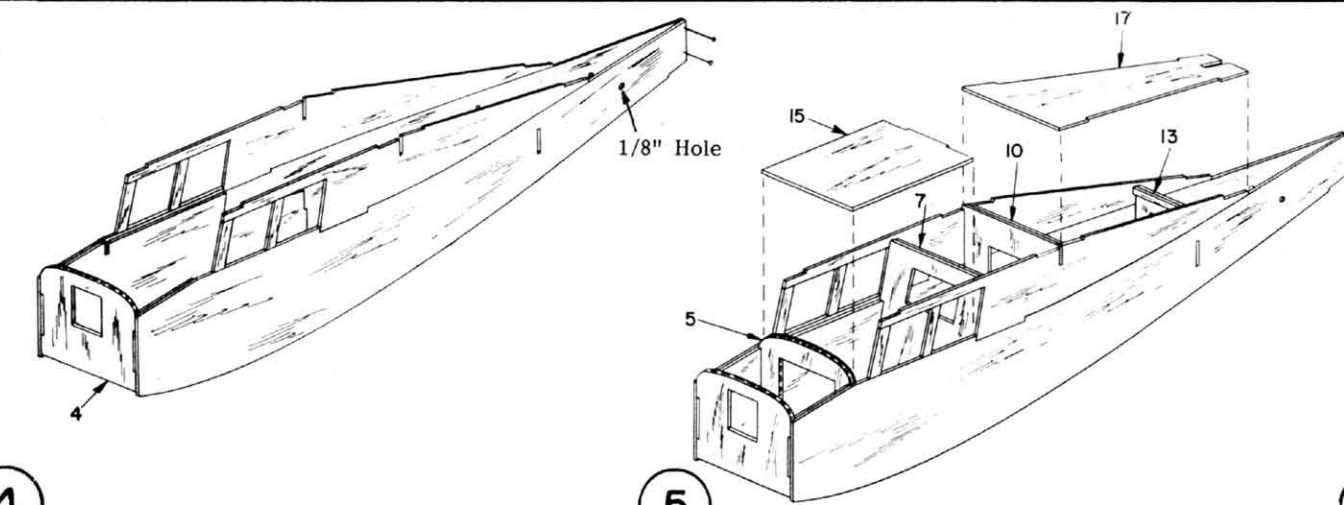

**4** If Model is being built for Rubber Power cut out creased area in center of Bulkhead #4 then Glue Bulkhead #4 between front of Fuselage Sides. Very Accurately match and glue back of Fuselage Sides together. Hold with Straight Pins or Tape until dry. Drill 1/8" diameter hole at Punch Marks on rear of Fuselage Sides.

**5** Glue Bulkhead #5 in place with #6 in back. Glue Bulkheads #7 and #10 in place with Braces in back. Glue Bulkhead #13 in place with Braces in front. Glue #15 into Cabin on Top of #3's as shown. NOTE: If model is being built for Control Line Flying #48 and #49 are Glued in here (with #49 on Bottom) in Place of #15. It will be necessary to trim 1/16" from Bottom of #6 since #48 is thicker than #15. Glue #17 in place.

**6** Hold #17 in Place with Tape until Glue dries. Glue #16 between Cabin Sides and hold with Tape. Wet both #20's with water so they bend easily, then Glue in place and hold with Tape.

**7** Glue #18 in place on Bottom of Fuselage and hold with Tape. Glue Landing Gear in place against Front of Bulkhead #5 and support with a piece of scrap Balsa against Front of Bulkhead #5 as shown. Glue #19 in place and hold with Tape. Glue Tailgear to Rear of Fuselage as shown. Glue #21 in place and hold with Tape. NOTE: If model is being built for Radio Control or Control Line Flying DO NOT Glue #21 in place at this time.

**8** Basic Fuselage is now complete and can be sanded smooth with Fine Sandpaper wrapped around a Block. Round off corners except where Tail Surfaces and Wing will join. Glue Bulkhead #47 to Front of Fuselage. Note that Tab on Bottom of #47 is flush with Bottom of Fuselage. Remainder of #47 is slightly undersize to allow for thickness of Plastic Cowl which is added later. Also Center of #47 is cut out along crease marks for Rubber Powered models ONLY.

**9** If model is to be painted or trimmed with Colored Tissue, see Instruction Booklet before going on. Make Two Wing Strut Assemblies - See Wing Strut Detail. Turn Plan over and build the Wing, Stabilizer and Rudder as described. Glue Wing and Stabilizer in place on Fuselage. Check model from Front and Rear for correct Line-Up (Alignment). Cut Two 3-1/4" lengths of 1/16" Dowel for Windshield Braces and Glue in place.

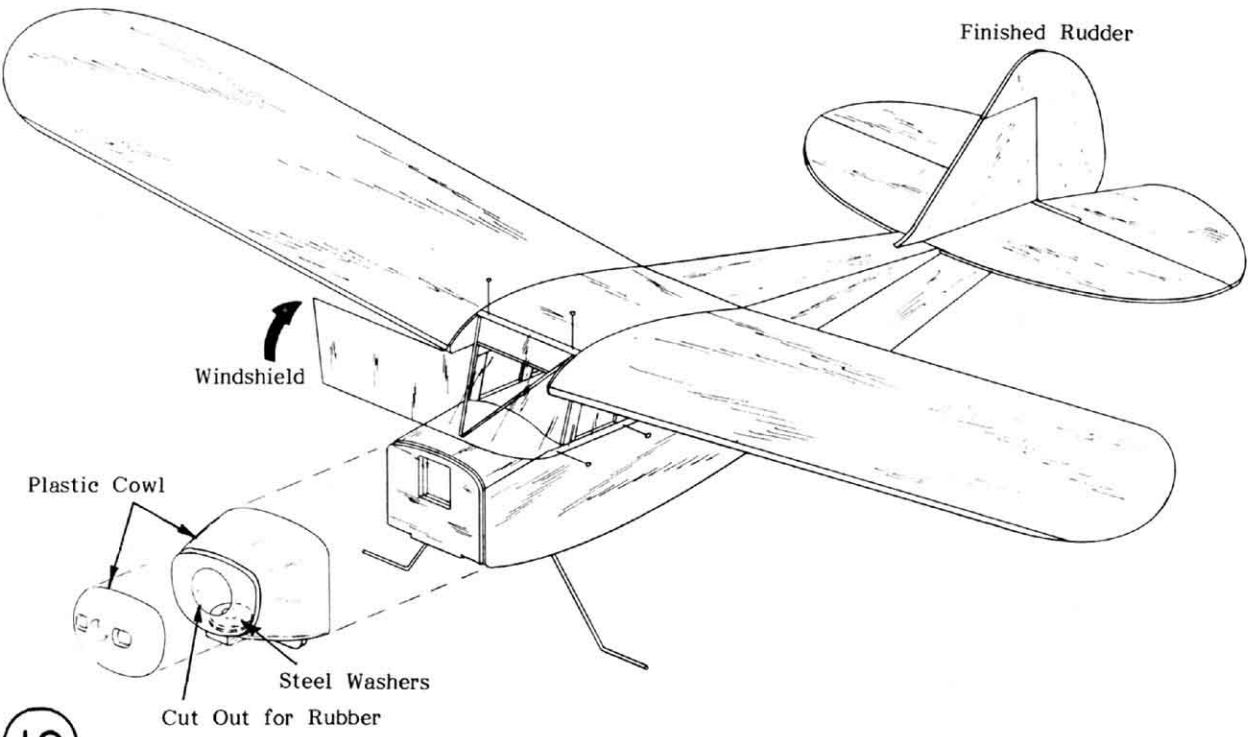

**10** Glue Rudder in Place. Wash Plastic Cowl and Pilot parts with soap and water. Rinse thoroughly and dry. Trim off excess Plastic and cement Cowl Parts and Pilot Halves together. Cement Steel Washers (for Balance) into Plastic Cowl (on Rubber models only). Cement Cowl to Front of Fuselage.

Cut Instrument Panel from Plan and Glue in place. Cut Bottom off assembled Pilot so it sits flat then cement Pilot in Cabin. Now wash, rinse and dry Clear Plastic Sheet, (Celluloid). Cut Windshield to shape from Celluloid. Cement Windshield in place being careful not to get cement on Window areas.

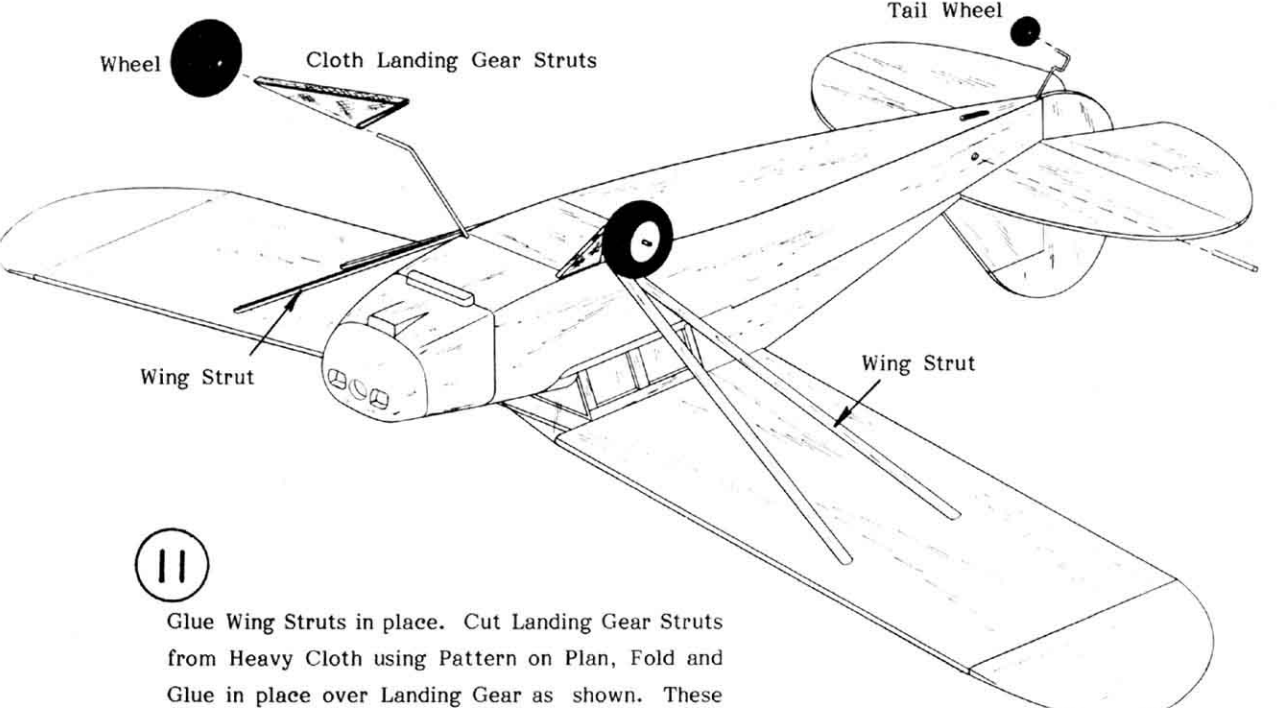

**11** Glue Wing Struts in place. Cut Landing Gear Struts from Heavy Cloth using Pattern on Plan, Fold and Glue in place over Landing Gear as shown. These Cloth Gear Struts allow models Landing Gear to Flex on Landings. Slip Wheels on Axles and hold with a drop of cement (Retainer) on the end of axle. Be certain Wheels spin freely. Push Eyelet into Tail Wheel then slip Wheel on Tailgear Axle and retain with drop of cement on end of Axle. 1/8" Diameter Piece of Dowel at Rear will hold Rubber Motor.

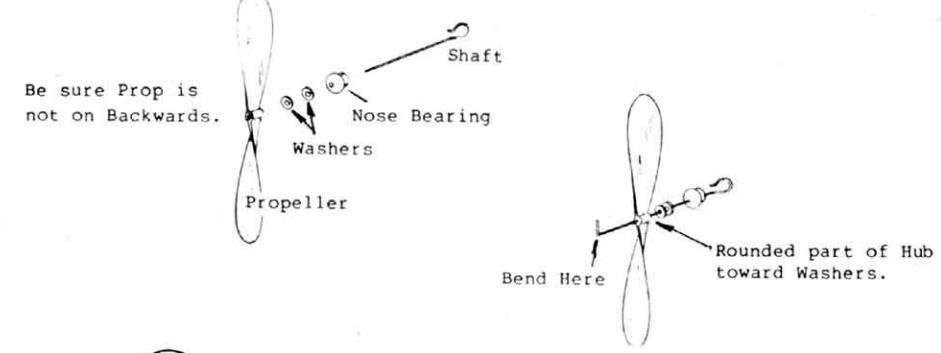

**12** Assemble Propeller parts as shown. Bend Front of Shaft over to engage Prop. Be sure Prop is not Backwards.

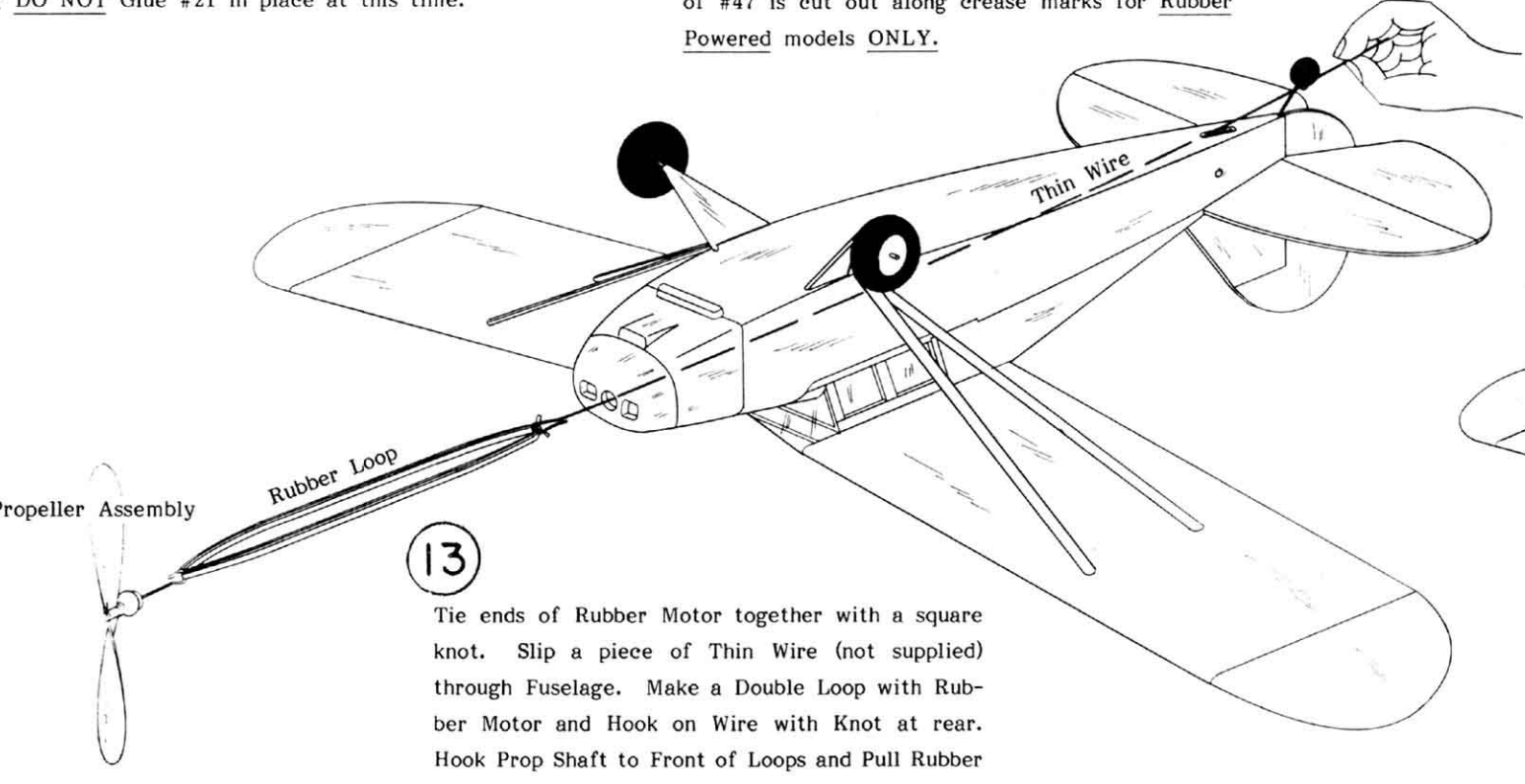

**13** Tie the ends of Rubber Motor together with a square knot. Slip a piece of Thin Wire (not supplied) through Fuselage. Make a Double Loop with Rubber Motor and Hook on Wire with Knot at rear. Hook Prop Shaft to Front of Loops and Pull Rubber back through Fuselage as shown.

**14** Hold Rubber Loops at Rear with Dowel. The Basic Model is now complete. See Flying Instructions before making any test flights.

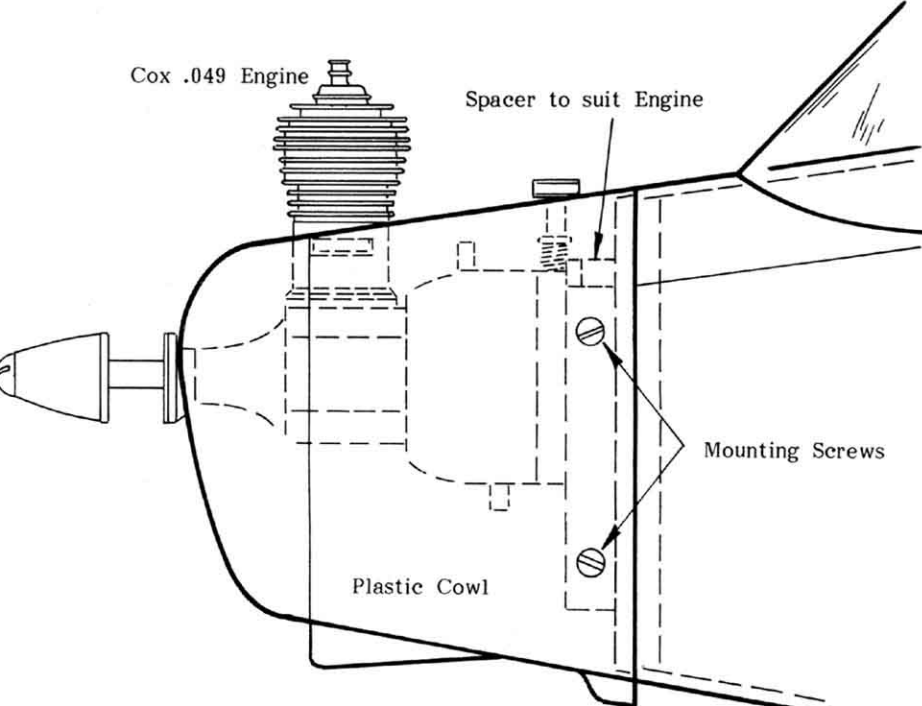

## ENGINE INSTALLATION

Engine (not supplied) is mounted directly to Front of Firewall #47 with Screws supplied. Drawing shows a Cox .049 Engine. Any suitable Engine can be used. Plastic Cowling is made removable as shown and described in C/L note. Cowling Must be trimmed to clear your Engine and allow sufficient cooling. Rear Bottom Fairing on Cowl is open to allow proper air flow and exhaust exit.

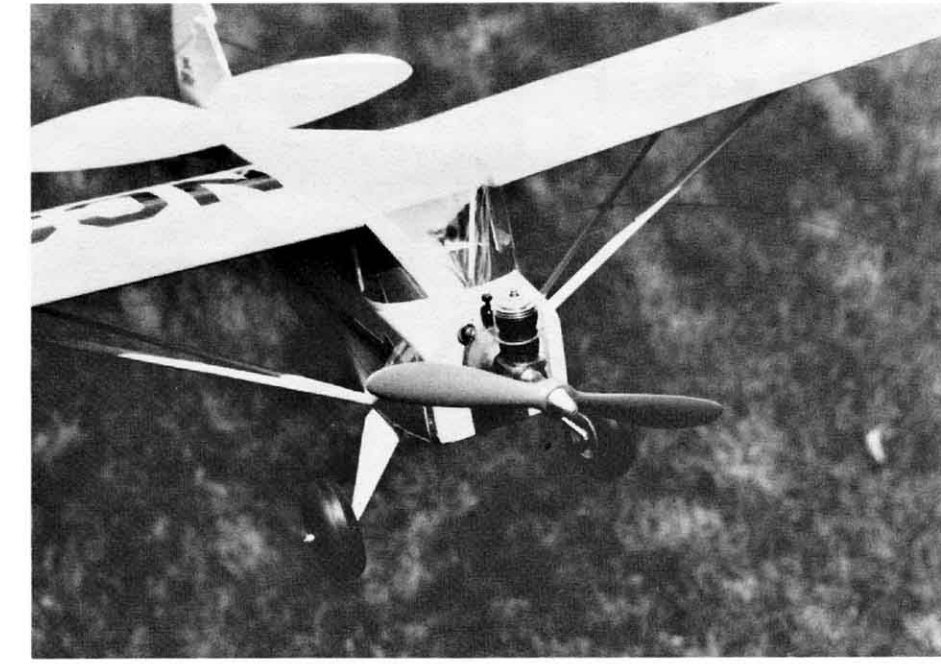
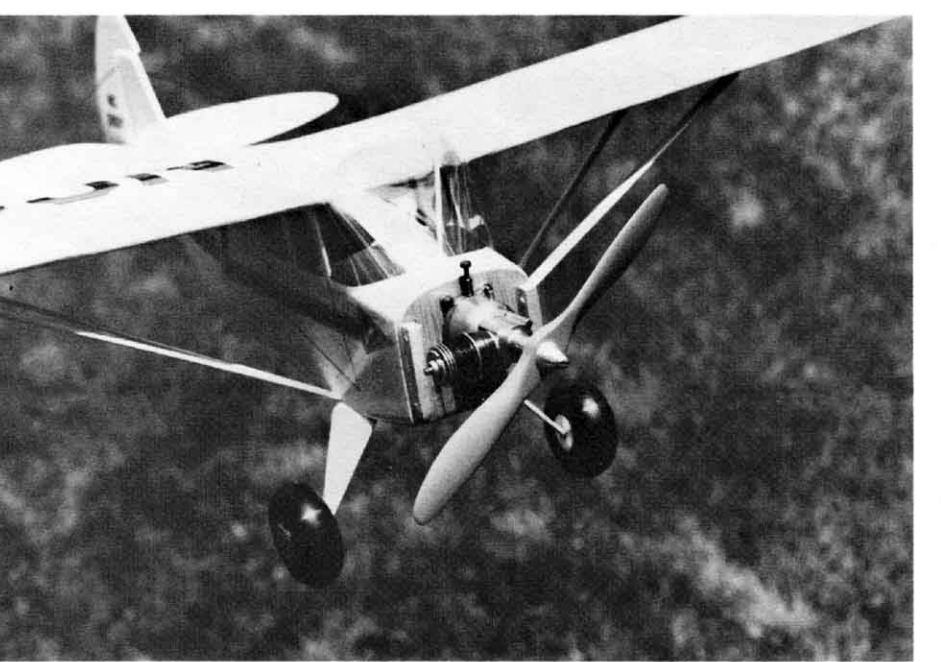

Photo Shows Cowling removed for Engine Access. Note Rudder Off-Set on this Control Line Model



Cowling in Place - Trimmed to suit Engine



Side mounted Engine on this Radio Control Model

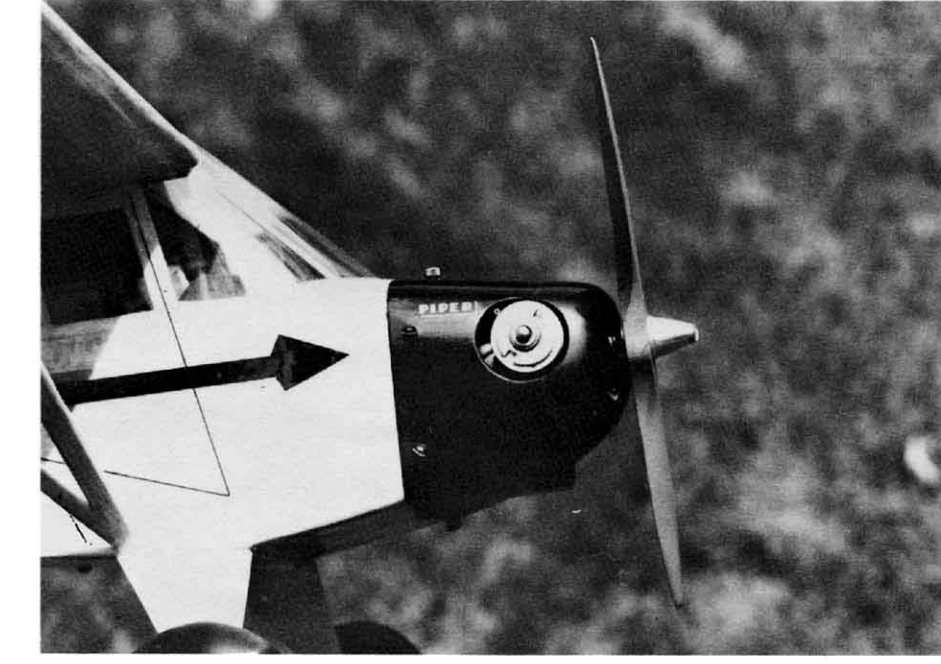

Cowling in place on this Sidewinder

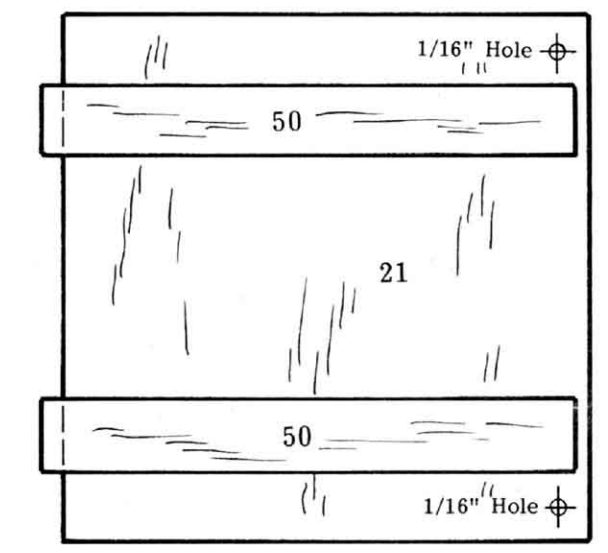

## ACCESS HATCH DETAIL

Assemble Hatch #21 by Gluing two #50's in place as shown. When dry drill two 1/16" holes as shown for mounting screws. Hatch is removable for access to Radio Equipment or Bellerank.

## Model Specifications

Wingspan: 33"  
Length: 22"  
Wing Area: 150 Sq. In.  
Scale: 1" = 10-5/8"  
Rubber Model Weight 6 to 7 oz.  
Control Line Model Weight 13 to 14 oz.  
Radio Control Model Weight 18 to 19 oz.

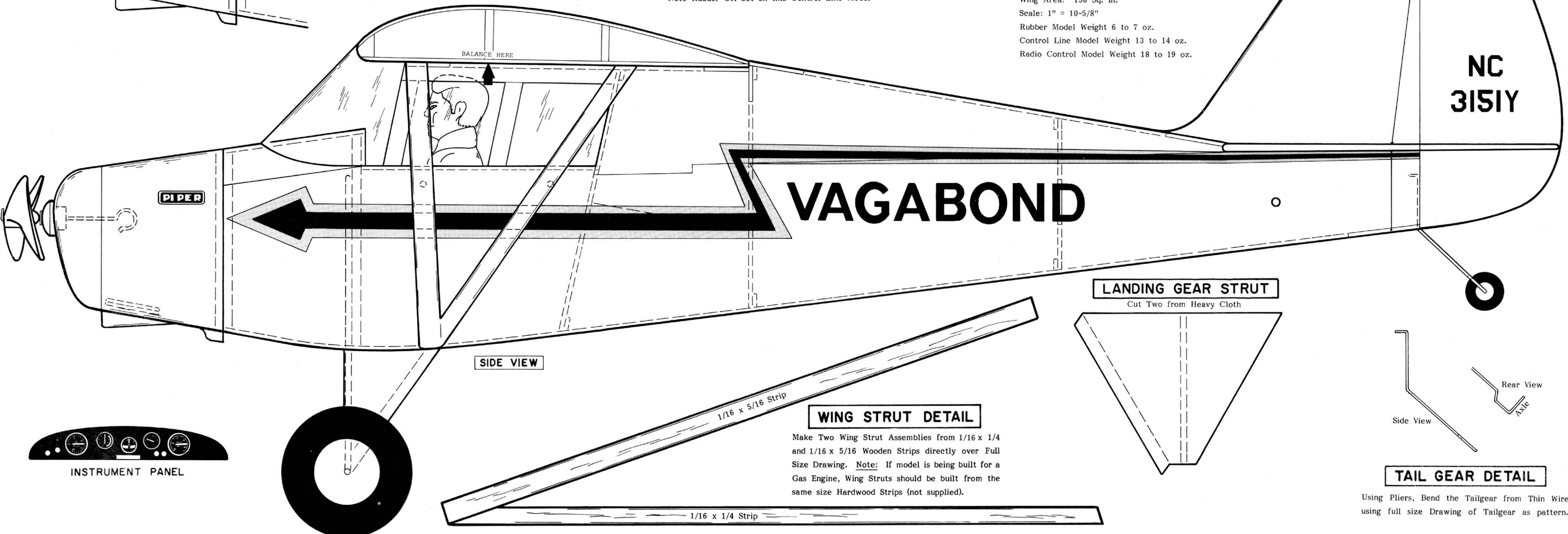

## WING STRUT DETAIL

Make Two Wing Strut Assemblies from 1/16 x 1/4 and 1/16 x 5/16 Wooden Strips directly over Full Size Drawing. Note: If model is being built for a Gas Engine, Wing Struts should be built from the same size Hardwood Strips (not supplied).

## LANDING GEAR STRUT

Cut Two from Heavy Cloth

## TAIL GEAR DETAIL

Using Files, Bend the Tailgear from Thin Wire using full size Drawing of Tailgear as pattern.

# For Rubber Power or Gas Engines—Free Flight, R/C or C/L PIPER VAGABOND



Kit K-7  
Wingspan: 33"

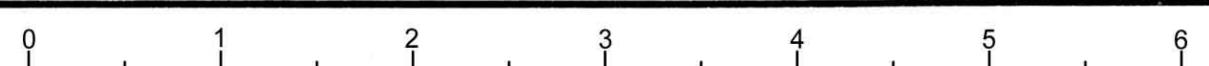

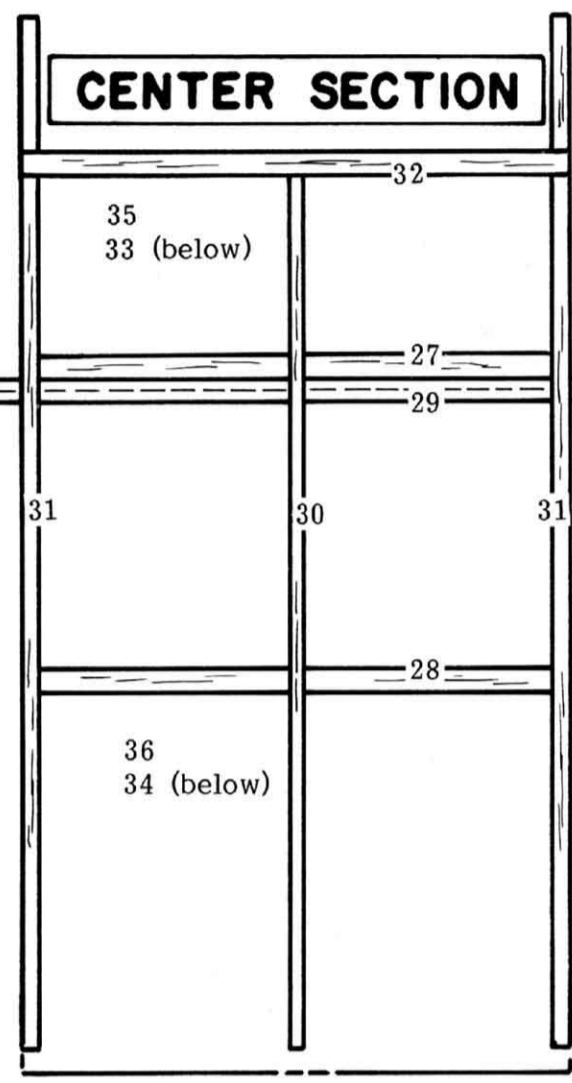
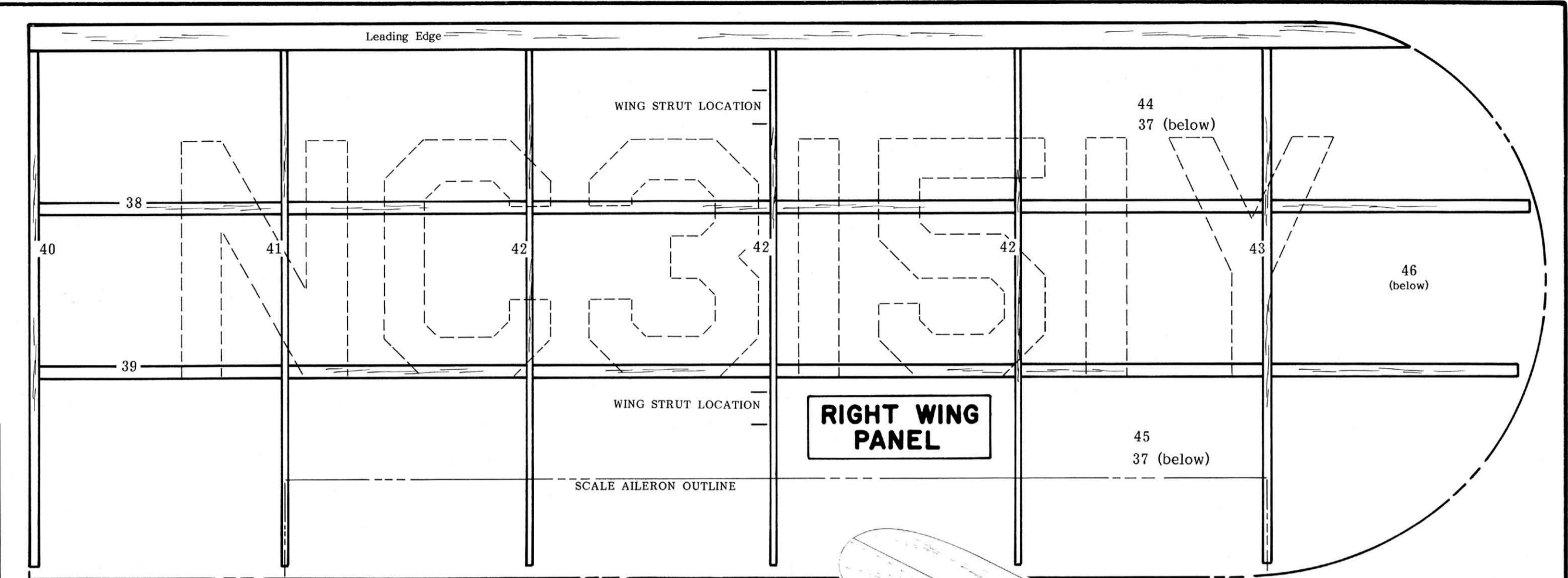
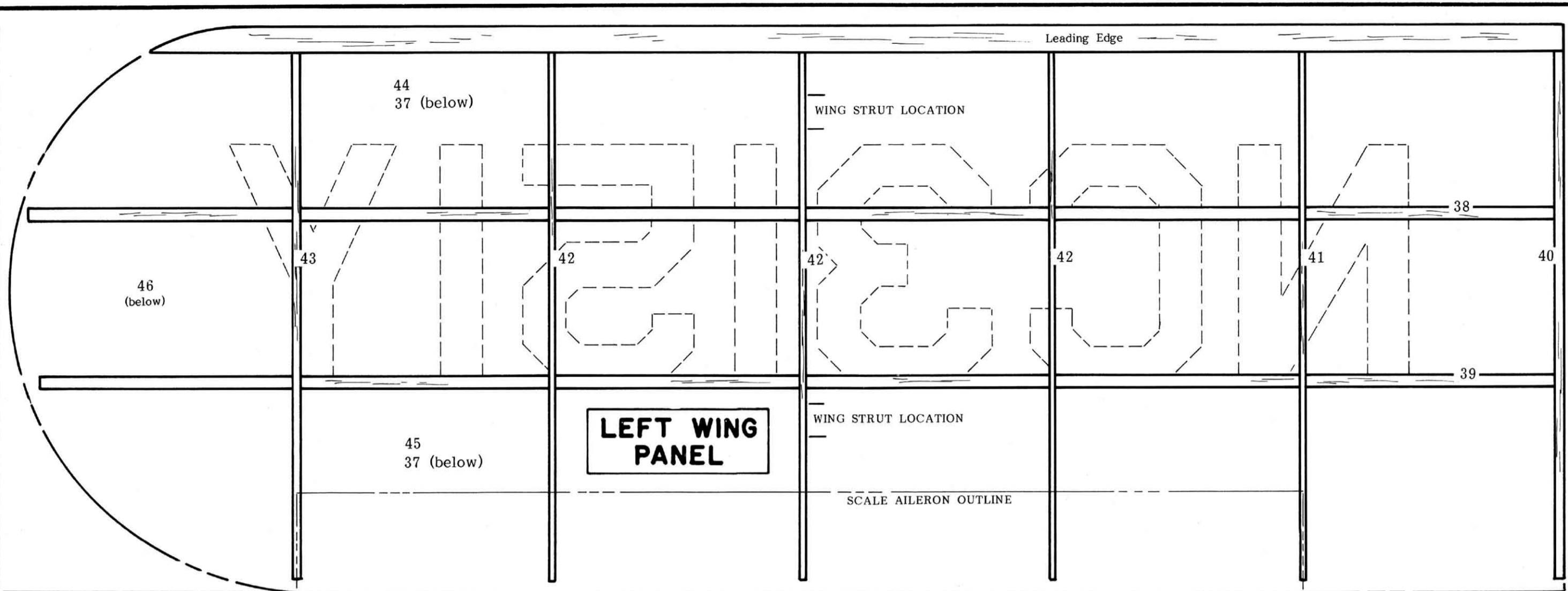

**WING ASSEMBLY**

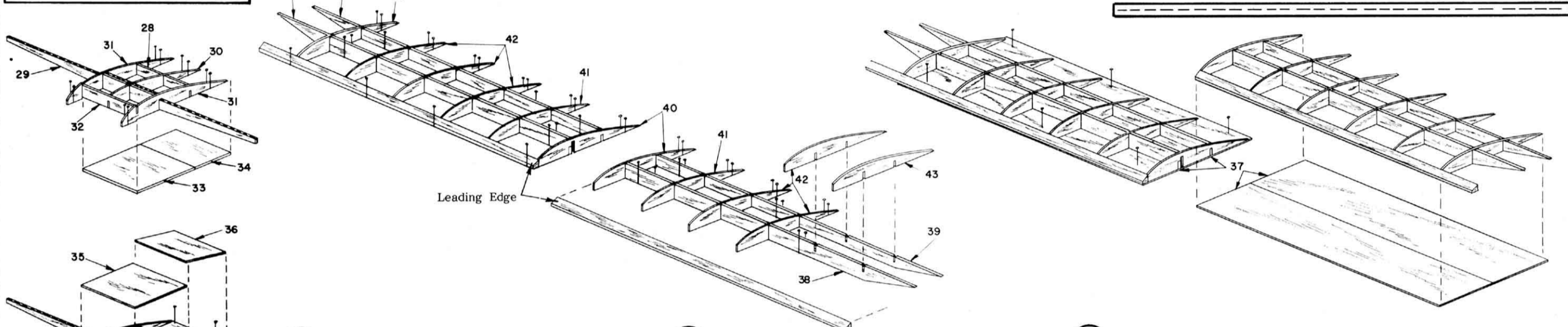

Build Wing directly over Film Covered Wing Drawing on Plan. Center Section is built first. Pin parts #33 and #34 to Plan Gluing together where they join. Pin and Glue remainder of parts #28, #29, #31's and #32 in place. Allow to dry thoroughly, then Glue and Pin Top Covers #35 and #36 in place.

Left and Right Wing Panels are built by Pinning all the parts shown in place Gluing them where they join. Allow to dry thoroughly.

Remove Wing Rib assembly from Plan. Glue these to Lower Sheets #37's as shown Pinning back on Board while Glue dries.

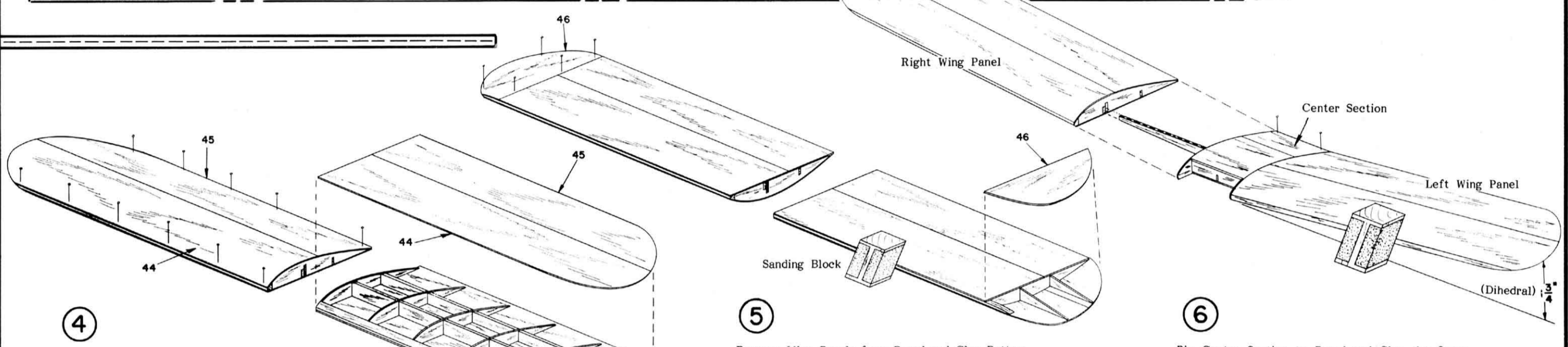

Remove Pins and now Glue Top Sheets #44's and #45's in place again Pinning back on Board until Glue dries.

Remove Wing Panels from Board and Glue Bottom Tip Parts #46 in place. Note that Leading Edge will have to be tapered slightly to receive #46. When Tips dry sand Wing Panels and Center Section smooth rounding off edges as shown.

Pin Center Section to Board and Glue the Outer Panels to it Blocking up Both Tips 1-3/4" as shown to form proper Wing Angle (Dihedral). When dry, complete sanding Wing.

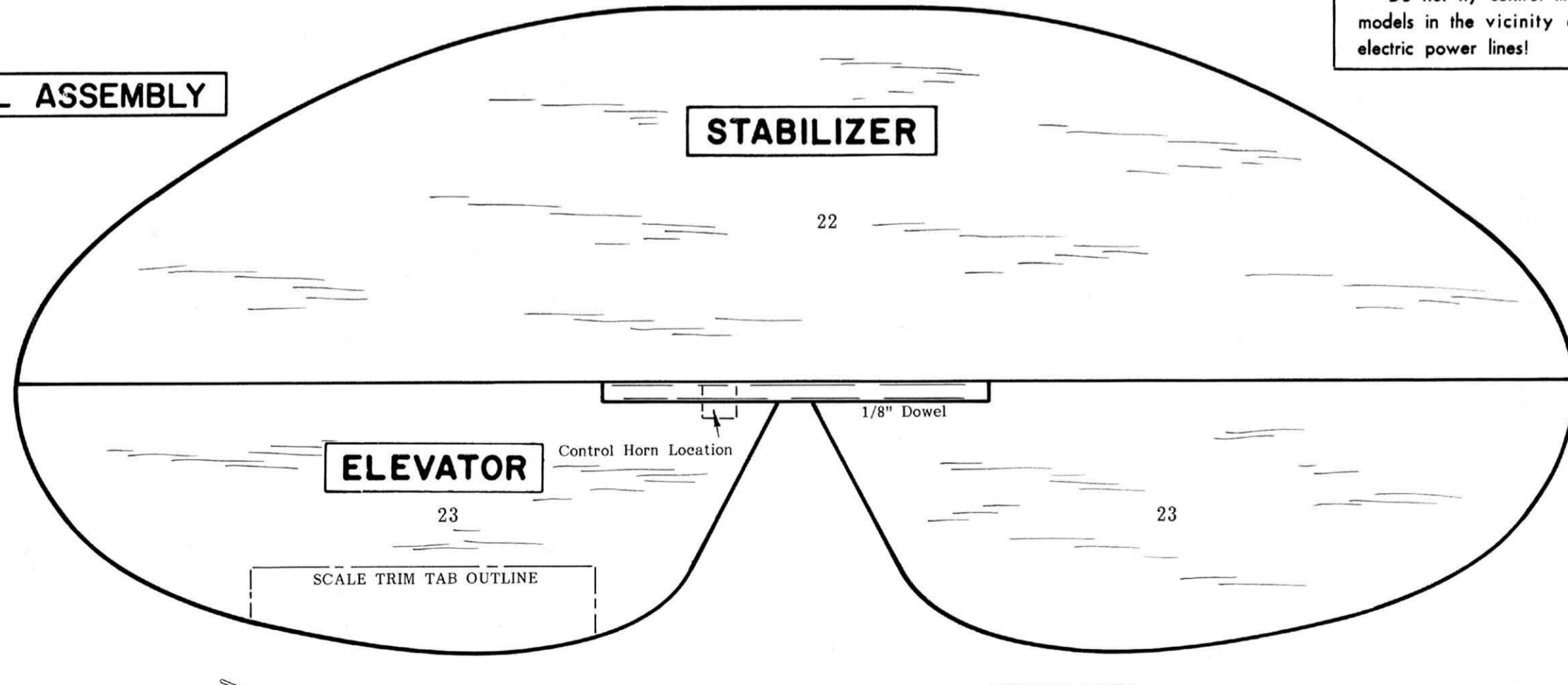
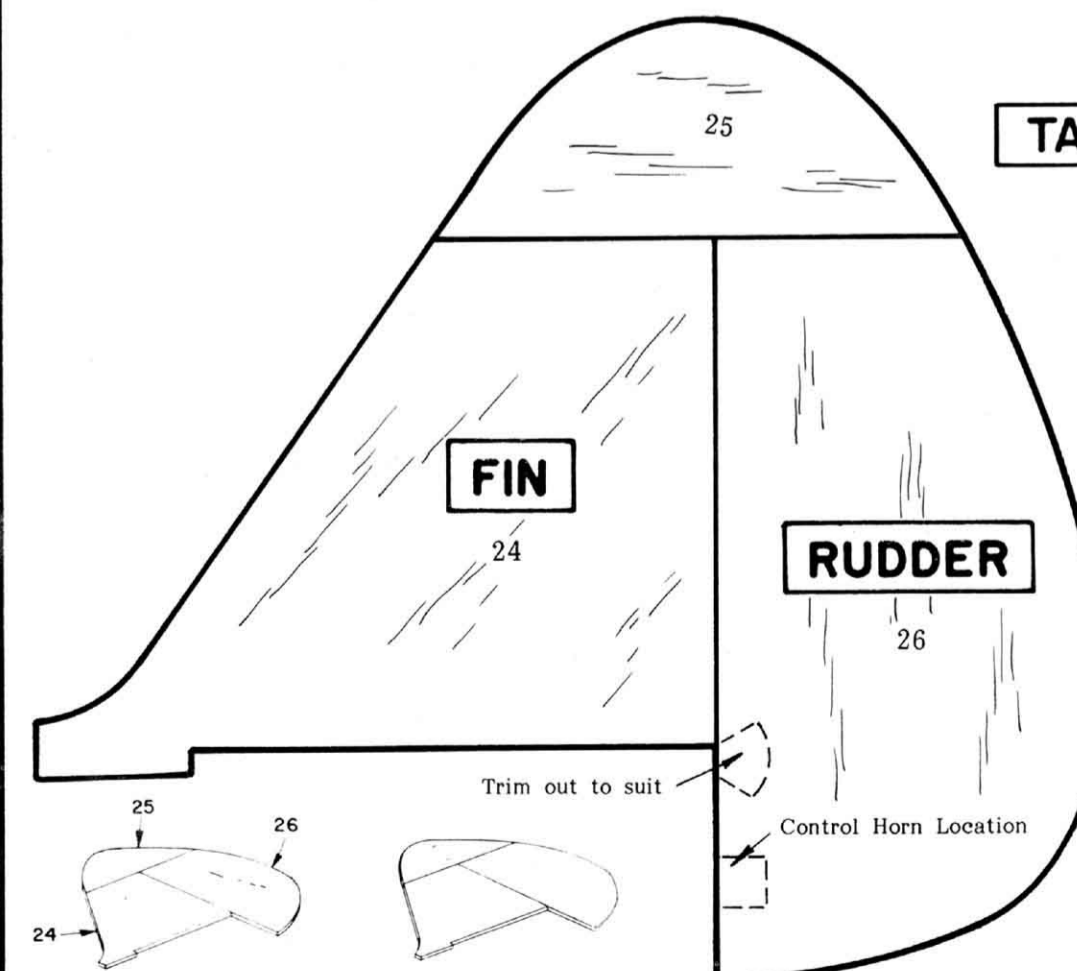
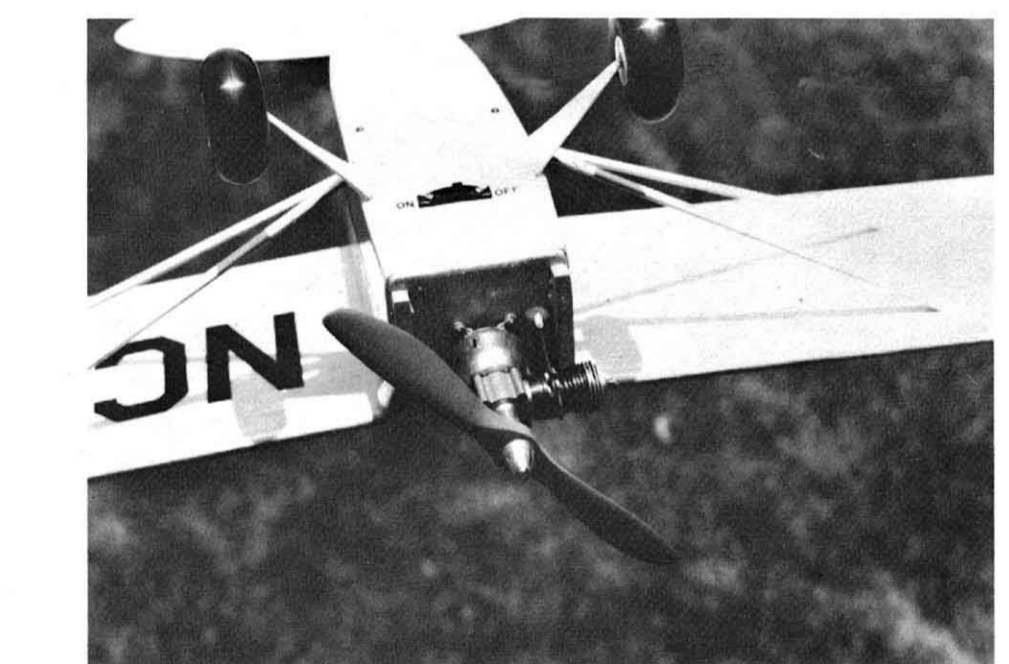
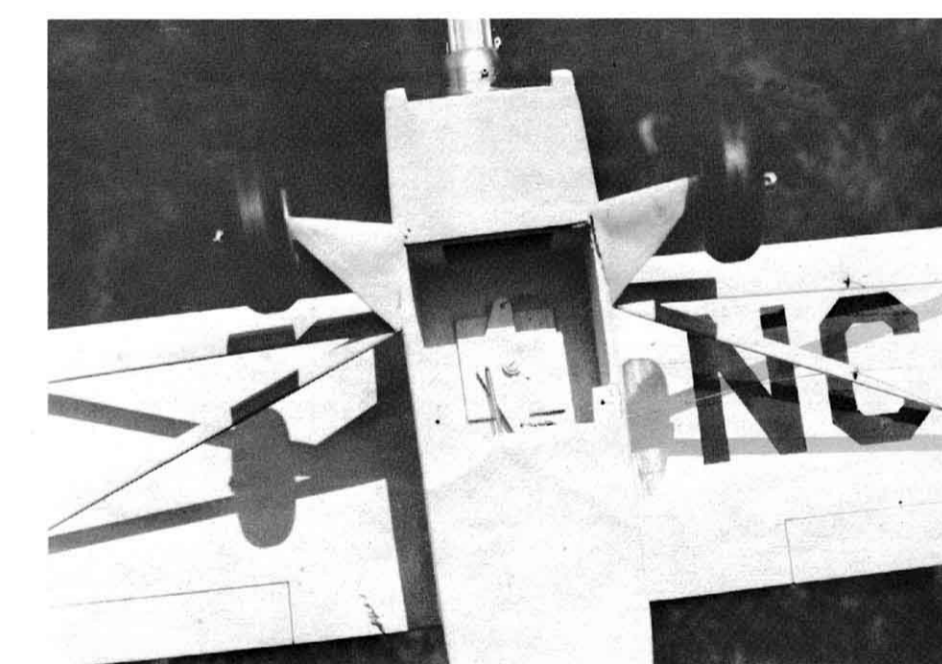
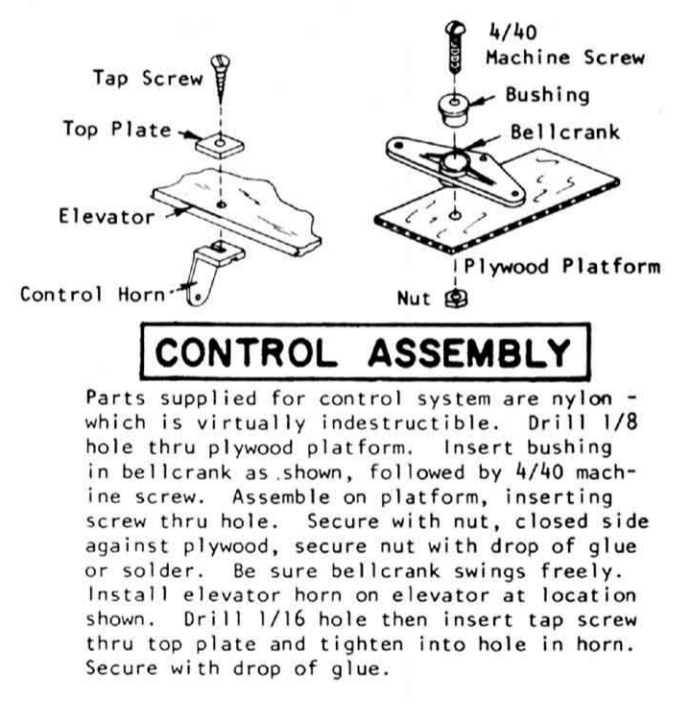
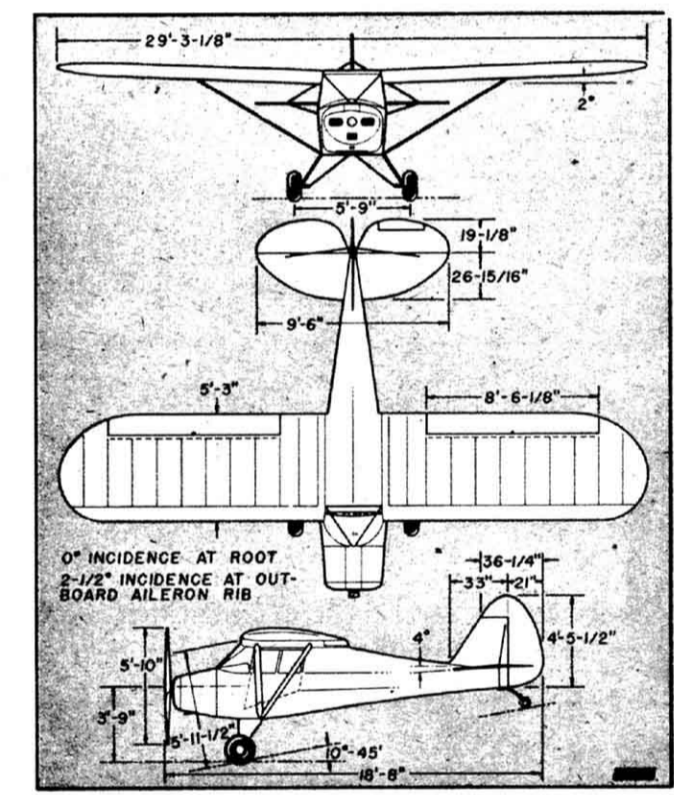
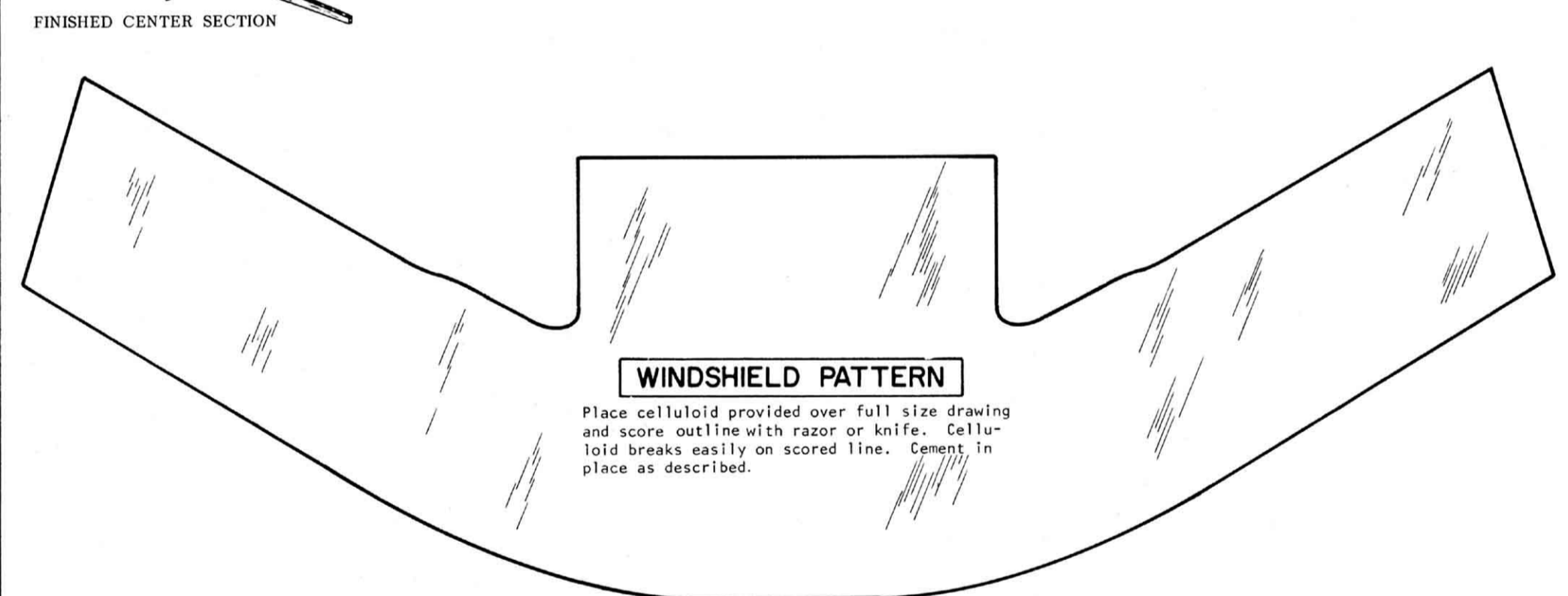

**RUDDER**

Glue Vertical Fin #24 and Rudder Parts #25 and #26 together as shown. NOTE: If model is being built for Radio Control or Control Line Flying, Rudder Parts #25 and #26 are glued together but Not to Vertical Fin #24.

**STABILIZER**

Glue Stabilizer #22 and Elevator Parts #23's together as shown with length of 1/8" Dowel. NOTE: If model is being built for Control Line or Radio with Elevator Control, Elevators #23's are joined with 1/8" Dowel but NOT Glued to Stabilizer #22. See R/C or C/L Stabilizer Detail.

**CAUTION:**  
Do not fly control line models in the vicinity of electric power lines!

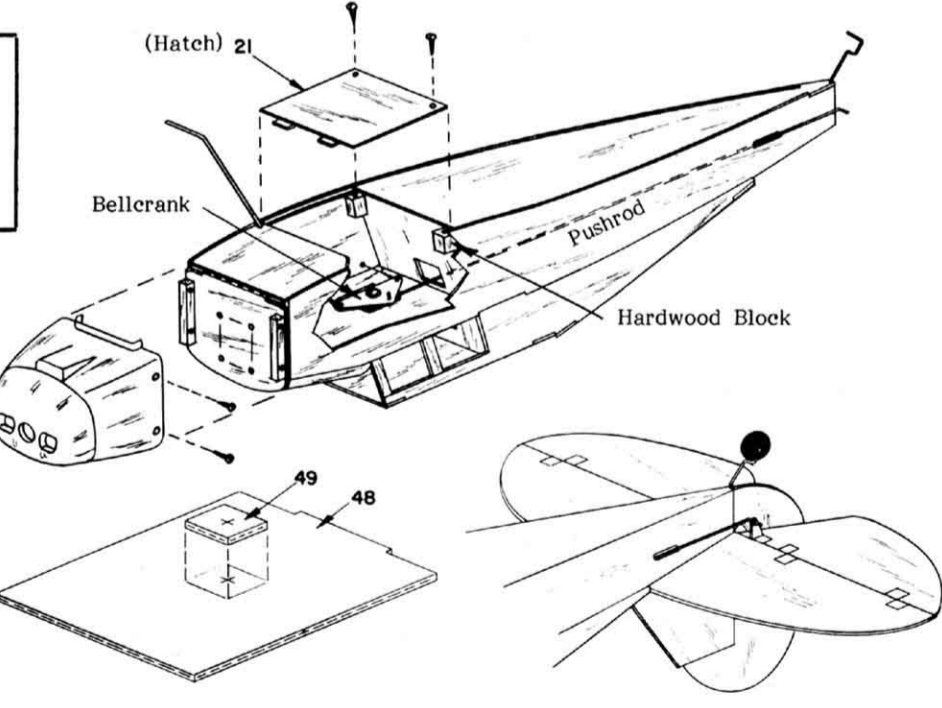

Drawing shows how parts #48 and #49 are glued together and mounted in Fuselage in place of #15. Drill a 1/8" hole through #48 and #49 at Punch Mark. Assemble Bellcrank as shown and tie the two 24" lengths of 1/2A Control Line (not supplied) to Bellcrank. Drill Lead-out Line Holes in Side of Body (See Side View). Bend one end of Pushrod wire at 90° as shown. Cut Slot in Side of Fuselage for Pushrod exit. Insert Pushrod, then mount Bellcrank in place capturing Front of Pushrod. Feed Lead-out Lines through Side of Fuselage. Glue two small hardwood Blocks into rear corner at #7 as shown. Assembled Hatch #21 is held in place by inserting Tabs #50's into cut outs in Bottom of #5 and two small Screws into Hardwood Blocks. Rear

of Pushrod is shown with a 90° bend - This is for clarity only and is done after Stabilizer is glued in place. The longer Hardwood Strips are Glued to the Front of #47 flush with Sides as shown. This allows Cowling to be held in place with Small Screws allowing easy access to the Engine. Also, Drawing shows how Center of Front Bulkheads were left intact with Holes Drilled instead to mount Gas Engine. Hole location on Bulkheads are for the Cox .049 Golden Bee Engine. Other Engines may require different locations, however Thrust Line must be maintained. When Gluing Vertical Fin to Fuselage, Rudder is glued on separately with it angled 1/2" to outside of circle.

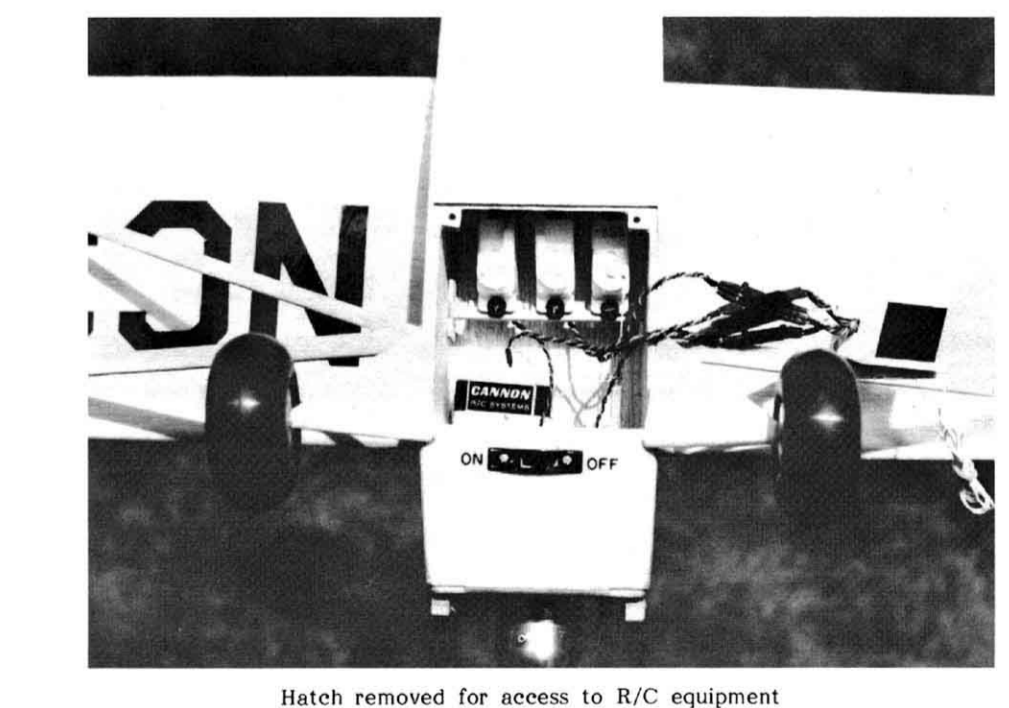
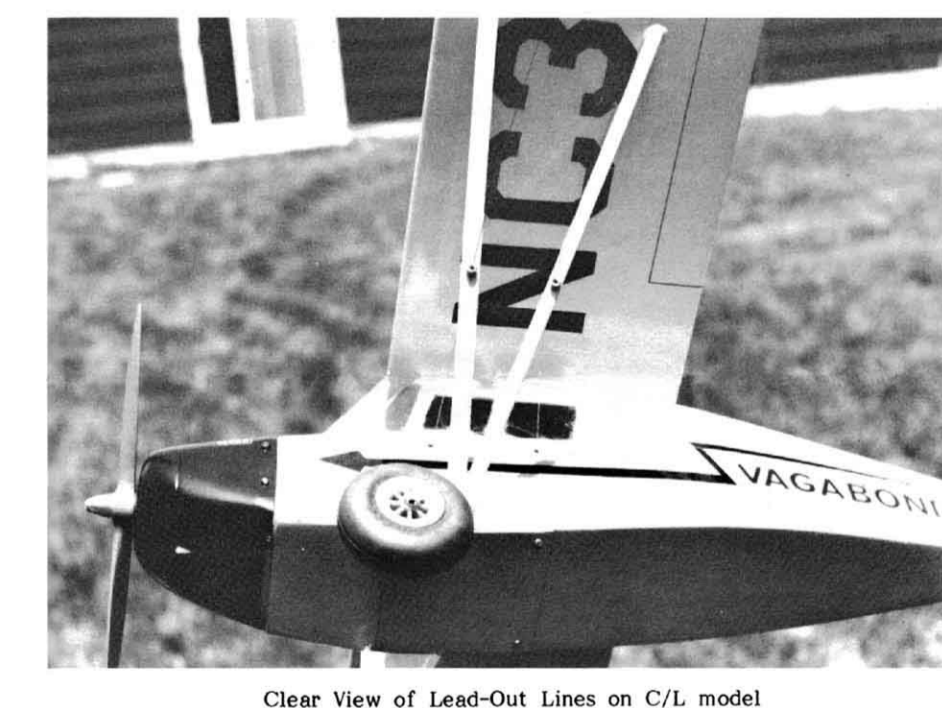

**RADIO CONTROL INSTALLATION**

If model is to be flown R/C then a Gas Engine must be installed. Radio Equipment (not supplied) is mounted and operated according to the manufacturer's instructions. Equipment location is as follows: Battery Pack in compartment between Bulkheads #4 and #5, (Bottom of #5 must be cut out to allow Battery insertion). Receiver directly behind Bulkhead #5 and Servos directly in Front of Bulkhead #7. Battery Pack and Receiver are wrapped in Foam, Servos mounted with Screws.

Company Models were flown with one Servo operating Rudder (single channel), Two Servos operating Rudder & Elevator (Two Channel), Two Servos operating Rudder & Throttle (again Two Channel), and Three Servos operating Rudder, Elevator and Throttle (Three Channel). The number of controls you select is strictly your choice. Each additional control function you add gives you that much more control of your model.

