

Insert small black wheel bearings firmly into hole in large wheels, brass bearing into small wheel.

FINAL ASSEMBLY

On R/C models, wing is removable as described in R/C Note. For other models, cement wing securely in fuselage between bulkheads F3 & F7, lining up ribs W2 & under side keels L5. Press wing tightly against L5's insure proper incidence otherwise model may not fly! Hold in place with pins until dry. When dry, remainder of 1/16 sa stringers are installed, including center keel L7. Sand smooth and cover completed bottom structure with silkspan as described in Covering Note. It is necessary to have access to rear hook to replace rubber motor. Cut out stringer immediately above side keel L4 on right side, between F10 & F11. Fit a piece of 1/16 balsa into space. Cement cloth tape to top (half over door and half over fuselage) to act as hinge. Cement a strip of 1/16 sq balsa to top of side keel L4 which will act as stop to keep the door flush with surface. Hold bottom with Scotch Tape. Insert stabilizer thru slot and cement in place against F11, resting on two washers provided, and insert rubber thru trap door and engage on rear hook. Slip remainder of rubber into fuselage and shake down towards nose. Make hook on end of a piece of wire. Slip wire thru nose bearing hole in cowl and capture rubber on hook. Pull thru cowl and attach rubber on prop shaft. Nose bearing fits into center hole in cowl. Your Chance-Vought F4U-5 Corsair is now complete. See Flight Instructions before flying. GOOD LUCK AND HAPPY LANDINGS!!!

door D1's to bottom of wing. Inside doors are on W3, outer doors are 1/2" from W5. Round off and cement mast into notch in L2. Model is now painted. If it is to be painted scale colors, see 3-View drawings or box top. For best flight performance use a minimum of color dope. Apply decals by dipping in water and sliding off into position shown. Cut instrument panel from plan and cement to rear of F5. Cement all plastic parts in place as described in detail note. Outlines of scale control surfaces can be drawn on with India Ink. Insert the bearings into wheels and place wheels on axles. Secure by bending up end of axles, or with drop of cement or solder. Insert straight end of propeller shaft to rear of nose bearing. Slip on two washers provided, and insert shaft to U shape as shown on side view and cement securely to propeller. Tie ends of rubber securely with square knot, wet with water first to prevent fraying. Double up to make 2 loops. Insert rubber thru trap door and engage on rear hook. Slip remainder of rubber into fuselage and shake down towards nose. Make hook on end of a piece of wire. Slip wire thru nose bearing hole in cowl and capture rubber on hook. Pull thru cowl and attach rubber on prop shaft. Nose bearing fits into center hole in cowl. Your Chance-Vought F4U-5 Corsair is now complete. See Flight Instructions before flying. GOOD LUCK AND HAPPY LANDINGS!!!

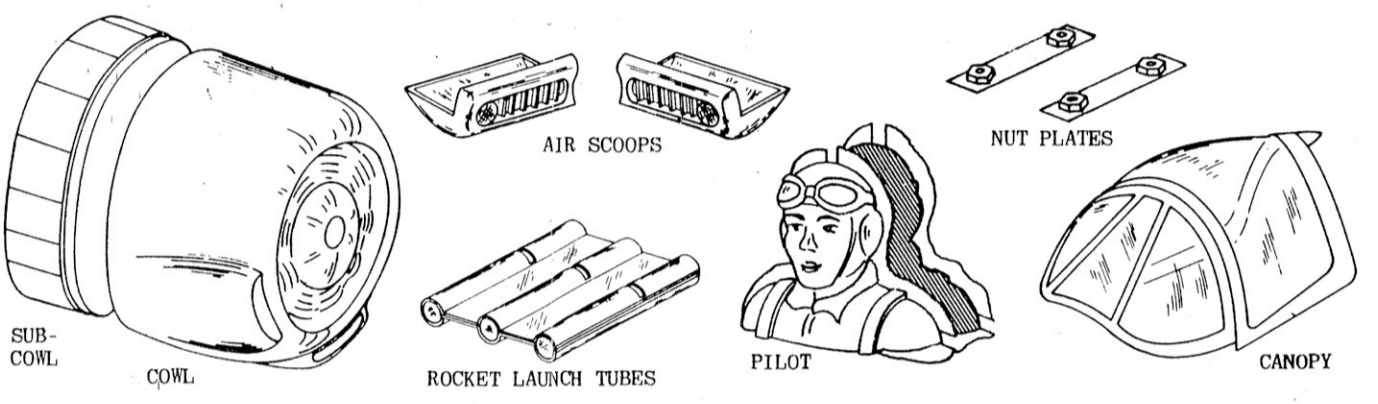

PLASTIC PARTS DETAIL

For best results, follow instructions carefully. SUB-COWL: Cut from sheet, leaving about 1/16 of material for trim. Slip sub-cowl over bulkhead F1 to F2, for support while trimming excess material away. Cut out long notches marked in plastic where cowl frame will be inserted when it is cemented against F1. Cement in place against F1 with cut outs vertical, and center spring line centered on L1. Use cement VERY SPARINGLY. Excessive cement will melt & distort plastic. COWL: Cut from sheet, leaving 1/16 excess for trim. Rear of cowl fits into step of sub-cowl at F1. Trim to fit. AIR SCOOP: Cut from sheet, trim, then cement to bottom and around front of wing against fuselage as shown. PILOT: Cut both halves from sheet leaving about 1/8 excess material. Carefully cut out slots about 1/8 wide on top, sides and bottom, right to the edge of the pilot half as shown. This will permit accurate assembly. Cement halves together, lining up carefully at slots. Use cement VERY SPARINGLY, since excessive use may distort or melt plastic. After assembly is thoroughly dry, trim and sand off

smooth. ROCKET LAUNCH TUBES: Cut both halves from sheet and assemble with slots in same manner as pilot. When dry, trim and sand smooth. Complete and install as described in Rocket Launch Tube Detail. NUT PLATES: Cut from sheet on trim lines and install as described in Engine Installation. CANOPY: Trim edges and fit in place on fuselage. Paint raised portions (frame) of canopy same color as fuselage. AFTER READING PAINT INSTRUCTIONS AT END OF THIS NOTE! PAINTING: Use regular plastic model paint or enamel. Model airplane dope can be used if necessary but only if applied in LIGHT SPRAY COATS, allowing paint to dry thoroughly between coats. Excessive use of dope may deform plastic. Parts may be used red, or if painting a lighter color, apply a light coat of silver, followed by a light coat of white; before painting final color. Darker colors may be applied directly to red plastic. Remember when using cement on plastic, use light coats applied sparingly. If necessary, use more than one coat, but DO NOT APPLY A THICK COAT AT ANY TIME.

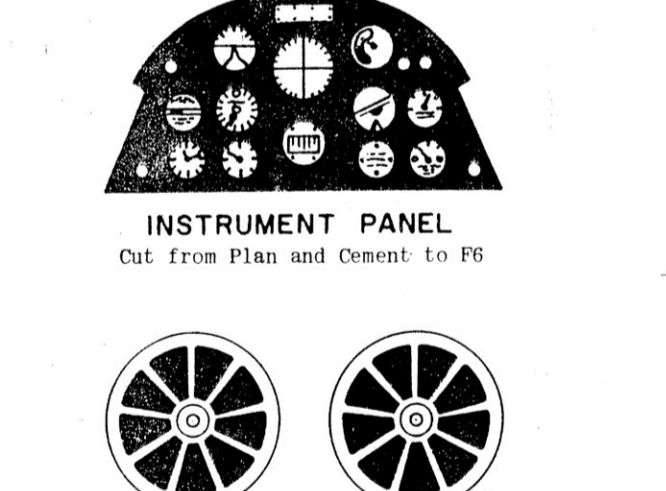

WHEEL COVERS

Cut wheel covers from plan and cement one to each wheel. The use of Contact Cement is recommended, although model cement will do. When installing wheels as described in Final Assembly, wheel covers should face wing tips as shown.

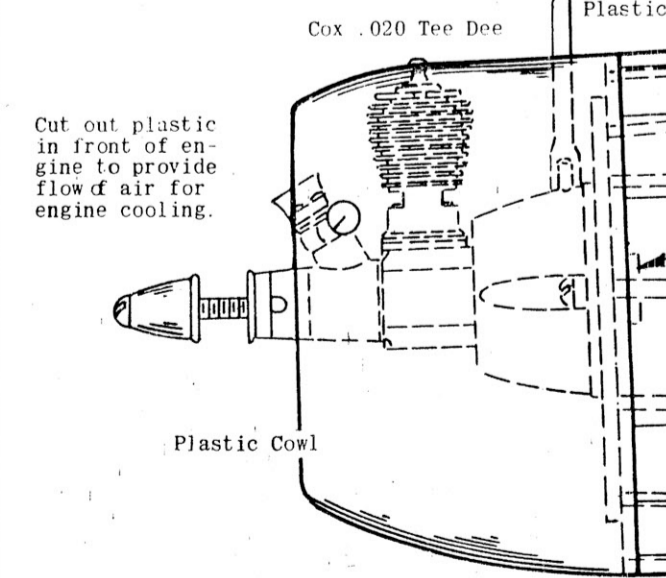

ENGINE INSTALLATION

Engine is used if model is being built for control line, free flight or radio. Engine & installation material not provided in kit. Drawing shows installation of Cox .020 Tee Dee Engine, however, any other similar engine may be used. Drill 1/8 holes at punch marks in plywood fire wall. Mount engine with #2 nuts & bolts. Cut plastic nut plates from molded sheet and securely cement to back of fire wall over nuts, drilling holes through, so that bolts can protrude. Use cement generously. Nut plate keeps nuts from turning, so engine can be removed by just unscrewing bolts from front. When dry, remove engine & securely cement engine fire wall to front of F1. Cut molded engine cowl from plastic sheet as described in detail note & fit over sub-cowl. Trim out top three cylinders in front

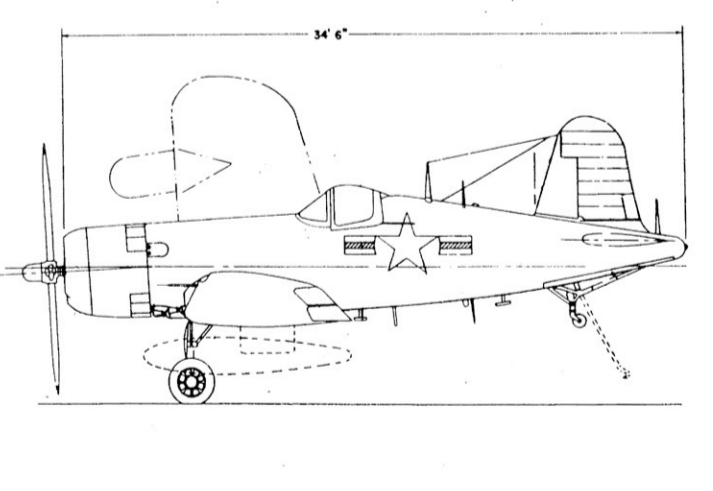

ROCKET AND TUBE ASSEMBLY

Assemble plastic rocket tubes as described in plastic parts note. Cut out the 1/16 wide slots in top of tubes. Slip rocket launch tubes into wooden end covers and cement end covers securely in place to end of tubes. Use two heavy coats of cement for maximum strength and allow to dry thoroughly. Cut 12 rocket tube pylons from 1/16 scrap balsa, using pattern provided, cement vertically to top of tube assembly. Unit is then cemented to bottom of wing. Position of pylons & tubes is shown on side view. SLOTS IN TUBES MUST BE DIRECTLY UNDER SLOT IN WING

of cowl, and also top front of cowl, for cooling. Make needle valve extension by forcing a length of 1/8 I.D. plastic fuel tubing over head of needle valve, then forcing a length of 1/8 dowel into end of tubing. Dowel should protrude at least 1/2" past cowl. Cut 1/16 I.D. plastic tubing for filler & overflow, & force tubing on tubes on top of fuel tank. Tubing should extend about 1/2" past cowl and top should be cut at angle facing forward for easy admission of air stream. Slot cowl for plastic tubes. Slots extend to rear of cowl so it can be removed. Cowl can be either tack glued or held with small wood screws. Remove needle valve from engine to install cowl. Cowl is installed after model is painted and replaced on model.

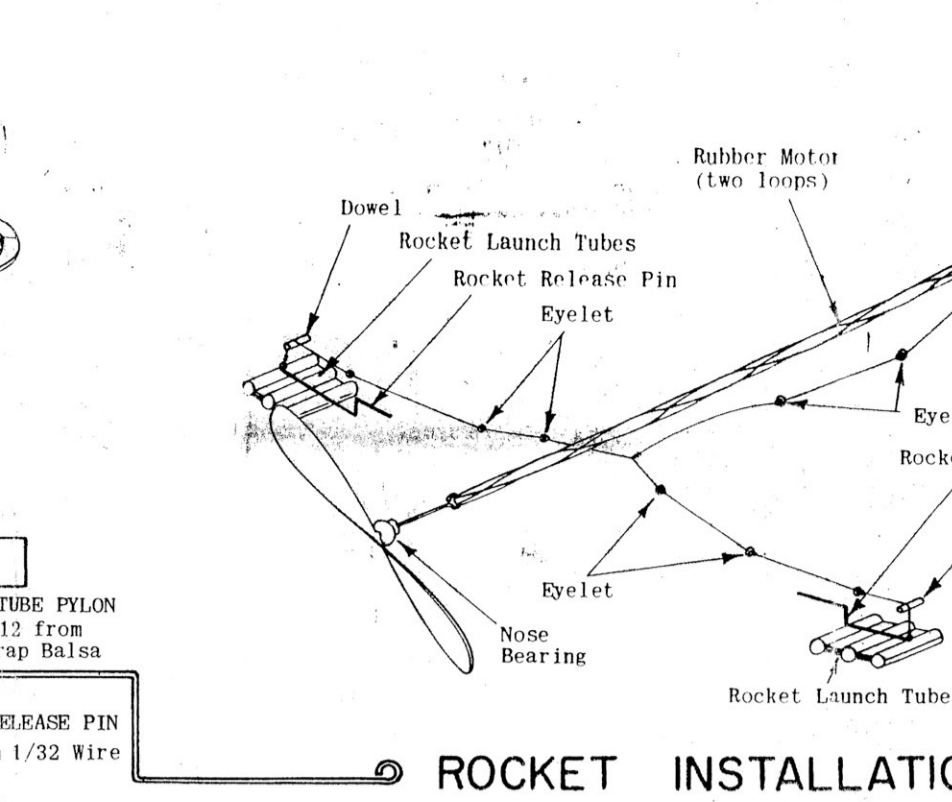

ROCKET INSTALLATION

Rocket firing is done automatically in flight on rubber powered models only. Installation is simple and action is positive. If directions are followed carefully. Make hole and cement eyelet thru bulkheads F7 & F9, and wing ribs W2, double Ribs W4 & W5, & W7. Make 1/8 dia. hole in W3 & W6 in line with eyelets for thread. Band 2 rocket release pins from 1/32 wire, using pattern provided. Insert rocket release pins thru slot in A, past rib W7, so that end with hook lies in slot formed between B & C, opposite straight end and is cemented and tied with thread to short 1/8 x 3/16 spar as shown in sketch and wing plan. Cement length of 1/8 dowel into notches across D & E. Insert thread thru holes and eyelets in ribs between W7's, leaving about 3" past W6 on each side. Place thread over 1/8 dowel and down along

ROCKET FIRING OPERATION

Automatic rocket firing in flight operates on rubber powered models only. It can also be triggered with third line on control line, or escapement on R/C models. Installation is simple and action is positive, if directions are followed carefully. Install mechanism as described in Rocket Installation Detail. To operate: Wind rubber motor. This will pull rear hook forward to a horizontal position, loosening thread. With tension released, rocket release pins enter slots in tubes to position shown in Sketch #1. Rockets are then inserted thru front and pushed back until rocket release pin is engaged in retaining groove in rear of rockets, locking them in place. Rockets are now loaded. Model is now released, and towards the end of the flight as motor unwinds, rear hook moves back to vertical position, tightening lines. This pulls rocket release pins out of groove, releasing rockets. At a time, outer ones fire, leaving tubes empty and release pins up, out of slots in tubes as shown in sketch #2. If rocket release pins are not pulled loose by rear hook returning to vertical position, then too much pressure is being exerted by coiled rocket launch spring in tubes. These should then be shortened, cutting off a loop at a time until spring of rear hook pulls release pins free, launching rockets. GOOD HINTING!!!

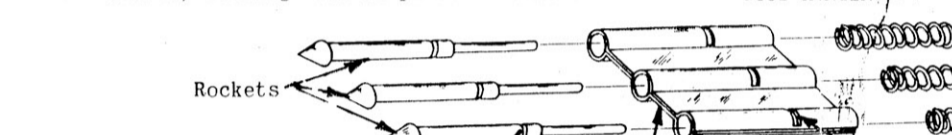

ROCKET AND TUBE ASSEMBLY

Assemble plastic rocket tubes as described in plastic parts note. Cut out the 1/16 wide slots in top of tubes. Slip rocket launch tubes into wooden end covers and cement end covers securely in place to end of tubes. Use two heavy coats of cement for maximum strength and allow to dry thoroughly. Cut 12 rocket tube pylons from 1/16 scrap balsa, using pattern provided, cement vertically to top of tube assembly. Unit is then cemented to bottom of wing. Position of pylons & tubes is shown on side view. SLOTS IN TUBES MUST BE DIRECTLY UNDER SLOT IN WING

F4U-5 CORSAIR SPECIFICATIONS AND COLOR SCHEME

Wing Span	41 Ft. 0 In.
Length	34 Ft. 6 In.
Height	13 Ft. 0 In.
Top Speed	465 M.P.H.
Ceiling	Over 40,000 Ft.
Engine	Patt. & Whitney R-2800 - 32W 2300 Horse Power
Propeller	13 Ft. 2 In.
Armament	Four 20 MM Cannon in Wing, Eight Rockets (5" HVAR) or Two 1,000 lb. Bombs

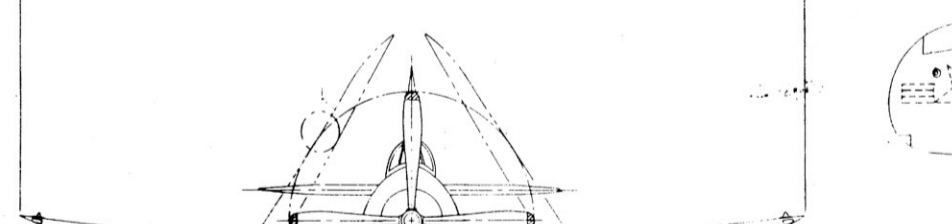

FLIGHT INSTRUCTIONS

When model has been completed, it must balance at point shown on side view. DO NOT ATTEMPT TO FLY MODEL UNTIL BALANCE HAS BEEN ACHIEVED, add weight if necessary. Check wing and tail. If warps have developed, remove using steam method described in Silkspan Step. Model is now ready. Pick a calm day for test flying. On rubber powered models, wind propeller clockwise approximately 100 turns and launch into any prevailing wind slightly nose down at a point on the ground approximately 50 feet ahead of you. If model noses up & then falls off & stalls, (AFTER MODEL WAS BALANCED) then bend elevators down slightly using hot breath in same manner as steam. If model dives, bend elevators up. If model veers too much to one side, bend rudder to opposite side. Take care to require more power and therefore more turns if rubber motor. Put long

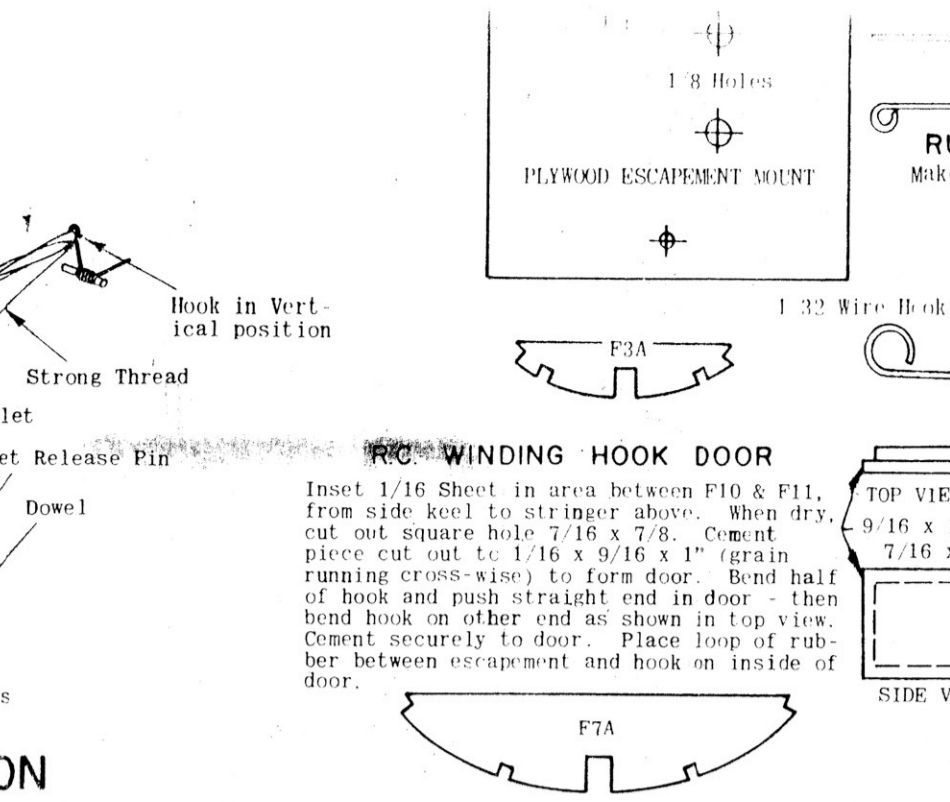

RADIO CONTROL INSTALLATION

Test models used, and drawing shows, Citizen-Ship MDL Receiver, SE2 Escapement; used with SPX Transmitter. This equipment and other material necessary is not provided in kit. On radio models, wing is removed. Pin, BUT DO NOT CEMENT, wing into position. Make F3A & F7A using patterns. Cement F3A to bottom of leading edge, and PIN it to F3. Do likewise with F7A on trailing edge. Since wing is removable, be sure not to cement F3A to F3 and F7A to F7. Complete bottom of wing installation as described in Final Assembly Note, however all stringers are cut thru at seams between double bulkheads, so that wing is removable. Cement a 3-1/2" length of 1/8 dowel across front of F3 and a 2-3/4" length across rear of F7 on top of stringer in line with top of LT. Dowels protrude evenly from fuselage on both sides. Remove center keel L3 between F3 and F5. Front half of entire fuselage is covered with 1/32 or 1/16 sheet balsa after R/C installation has been completed. Balsa is also covered with silkspan as described in note. Cut rudder apart at location shown by dotted lines, then assemble together

CONTROL ASSEMBLY

Drill 1/8 hole thru plywood platform. Insert bell crank thru bell crank and run nut up bolt till bell crank has just enough room to swing freely, closed face of nut down. Insert thru platform and install bottom nut closed face up. Tighten nut towards each other leaving bell crank to pivot freely. Secure nuts with solder or glue.

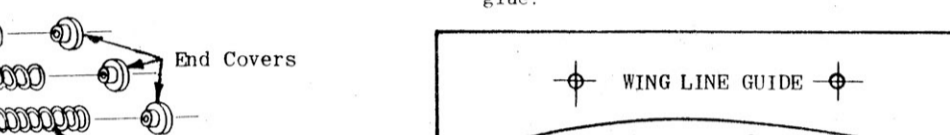

CONTROL LINE INSTALLATION

Install controls after Fuselage Step 4 has been completed. Fill in area between F2 & F5 from side keel L4 to stringer above it with scrap 1/16 sheet balsa flush with outside of fuselage. Also area from F11 to rear, between S and stringer below, in same manner. Cut 1/8 slot in rear for control rod as shown. Mount 1/2A bell crank to plywood platform as described in installation detail. Cut two 18" lengths of lead-out lines & fasten them to bell crank. Cement platform securely in fuselage against front of F1, and top of L4's. Lead-out lines come thru fuselage at holes drilled for them as shown. Use cement generously, applying at least two coats on installation. Front half, or entire fuselage, is covered with 1/32 or 1/16 balsa. Cover entire fuselage with tissue as described in detail note. Cut stabilizer in half thru wide main spar, as indicated by dotted lines. Round edges and install control horn at location shown on drawing, then join together with cloth hinges shown. Cement stabilizer horizontally to top rear of fuselage. Clear as necessary for elevator movement. Tape elevators in neutral position (in line with stabilizer, neither up or down). Obtain a piece of 1/16 music wire at least 15" long for control rod, and bend 1/4" of one end at right angle. Loosen bell crank and insert rod from bot-

HINGE DETAIL

Use cloth tape for hinges. Cement only on top and bottom, alternating hinges as shown above. Keep cement out of hinged area between sections.

CAUTION:

Do not fly control line models in the vicinity of electric power lines!

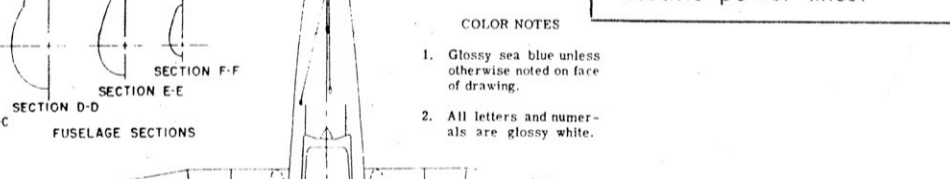

FLIGHT INSTRUCTIONS

When model has been completed, it must balance at point shown on side view. DO NOT ATTEMPT TO FLY MODEL UNTIL BALANCE HAS BEEN ACHIEVED, add weight if necessary. Check wing and tail. If warps have developed, remove using steam method described in Silkspan Step. Model is now ready. Pick a calm day for test flying. On rubber powered models, wind propeller clockwise approximately 100 turns and launch into any prevailing wind slightly nose down at a point on the ground approximately 50 feet ahead of you. If model noses up & then falls off & stalls, (AFTER MODEL WAS BALANCED) then bend elevators down slightly using hot breath in same manner as steam. If model dives, bend elevators up. If model veers too much to one side, bend rudder to opposite side. Take care to require more power and therefore more turns if rubber motor. Put long

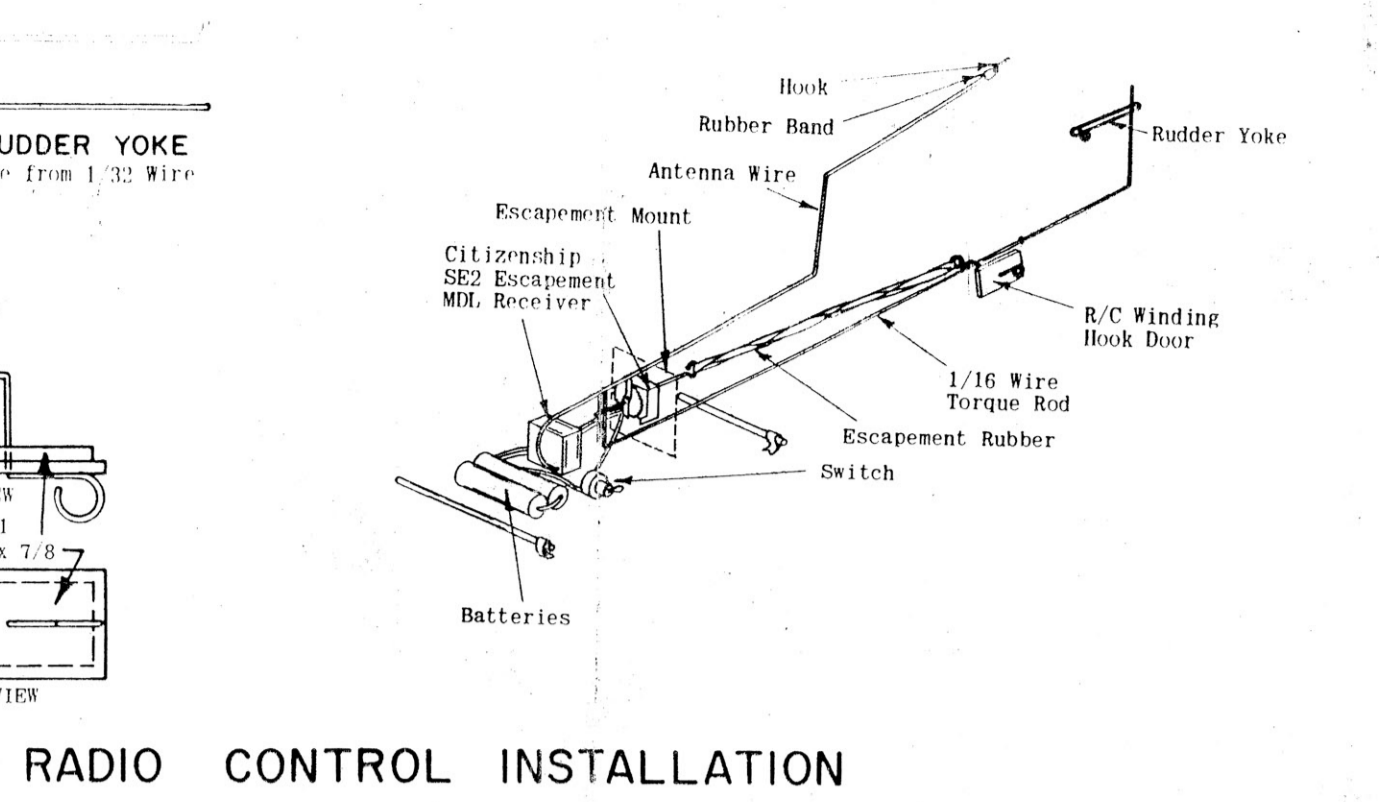

RADIO CONTROL INSTALLATION

with cloth hinges. Bend wire yoke from 1/32 wire and install on rudder with 2/56 nut and bolt. Cut escapement base from 1/16 plywood and cement to front of F5. When dry, install escapement with 2/56 nuts and bolts. Cut slots for torque rod thru R1 and L2. Insert a long length of 1/16 wire thru hole in F11 for torque rod. Bend U in front of rod, according to R/C manufacturer's instructions and shown above, then pull back and engage in escapement as shown. Bend rear as shown. Cut off excess wire, then engage in yoke. Raising and lowering yoke will increase or decrease the amount of rudder movement. Batteries are stored horizontally in section between F3 & F4. Receiver is located between F2 & F4. Wire radio equipment in accordance with manufacturer's instructions. After unit is wired, line compartment with foam rubber and insert batteries, followed by receiver which is also surrounded in foam rubber. Be careful not to break any wire connections. Bend small hook for antenna and cement to front of rudder. Bring antenna out of cockpit and fasten to hook with rubber band.

CONTROL ASSEMBLY

Drill 1/8 hole thru plywood platform. Insert bell crank thru bell crank and run nut up bolt till bell crank has just enough room to swing freely, closed face of nut down. Insert thru platform and install bottom nut closed face up. Tighten nut towards each other leaving bell crank to pivot freely. Secure nuts with solder or glue.



CONTROL LINE INSTALLATION

Install controls after Fuselage Step 4 has been completed. Fill in area between F2 & F5 from side keel L4 to stringer above it with scrap 1/16 sheet balsa flush with outside of fuselage. Also area from F11 to rear, between S and stringer below, in same manner. Cut 1/8 slot in rear for control rod as shown. Mount 1/2A bell crank to plywood platform as described in installation detail. Cut two 18" lengths of lead-out lines & fasten them to bell crank. Cement platform securely in fuselage against front of F1, and top of L4's. Lead-out lines come thru fuselage at holes drilled for them as shown. Use cement generously, applying at least two coats on installation. Front half, or entire fuselage, is covered with 1/32 or 1/16 balsa. Cover entire fuselage with tissue as described in detail note. Cut stabilizer in half thru wide main spar, as indicated by dotted lines. Round edges and install control horn at location shown on drawing, then join together with cloth hinges shown. Cement stabilizer horizontally to top rear of fuselage. Clear as necessary for elevator movement. Tape elevators in neutral position (in line with stabilizer, neither up or down). Obtain a piece of 1/16 music wire at least 15" long for control rod, and bend 1/4" of one end at right angle. Loosen bell crank and insert rod from bot-

HINGE DETAIL

Use cloth tape for hinges. Cement only on top and bottom, alternating hinges as shown above. Keep cement out of hinged area between sections.

CAUTION:

Do not fly control line models in the vicinity of electric power lines!

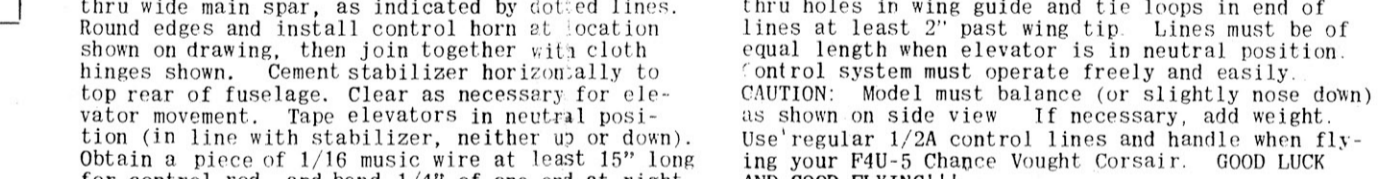

FLIGHT INSTRUCTIONS

When model has been completed, it must balance at point shown on side view. DO NOT ATTEMPT TO FLY MODEL UNTIL BALANCE HAS BEEN ACHIEVED, add weight if necessary. Check wing and tail. If warps have developed, remove using steam method described in Silkspan Step. Model is now ready. Pick a calm day for test flying. On rubber powered models, wind propeller clockwise approximately 100 turns and launch into any prevailing wind slightly nose down at a point on the ground approximately 50 feet ahead of you. If model noses up & then falls off & stalls, (AFTER MODEL WAS BALANCED) then bend elevators down slightly using hot breath in same manner as steam. If model dives, bend elevators up. If model veers too much to one side, bend rudder to opposite side. Take care to require more power and therefore more turns if rubber motor. Put long

© STERLING MODELS 1964
This material may not be used except with written permission of Sterling Models
Patent Pending-All Rights Reserved

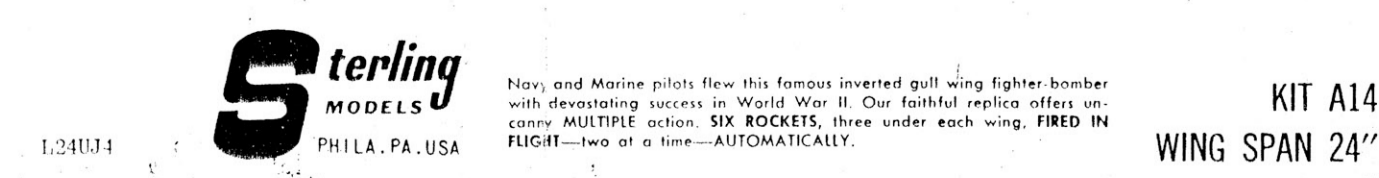

STERLING MODELS 1964
PHILA., PA. USA
KIT A14
WING SPAN 24"

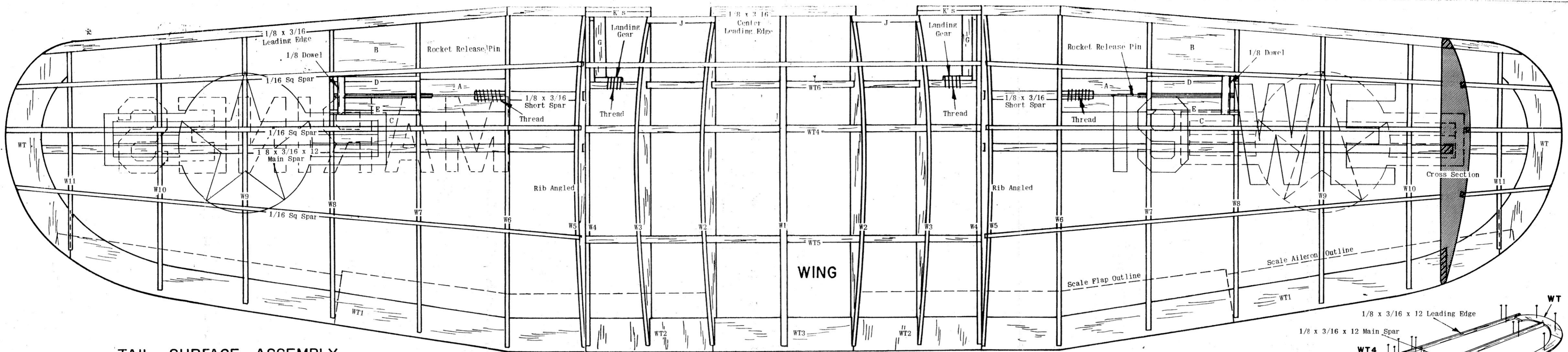

TAIL SURFACE ASSEMBLY

Assemble stabilizer by pinning all S parts shown to plan on flat surface, and cementing to each other where they join. Cut 1/16 x 3/32 strips to fit and cement in place upright. Rudder is built in same manner, pinning all R parts to plan and cementing to each other; then adding 1/16 x 3/32 strips. Allow assemblies to dry thoroughly on flat surface, then sand smooth, rounding edges (except bottom of R) as shown on cross-section. If model is being constructed for control line or radio, see respective detail notes BEFORE covering with tissue.

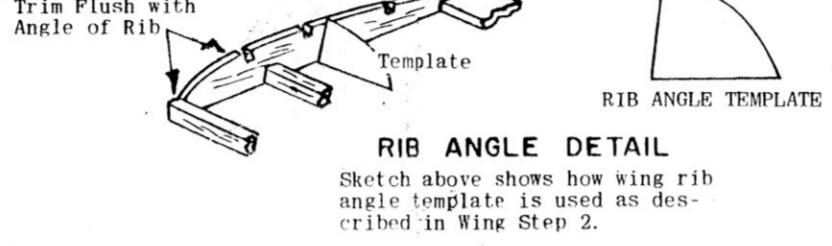
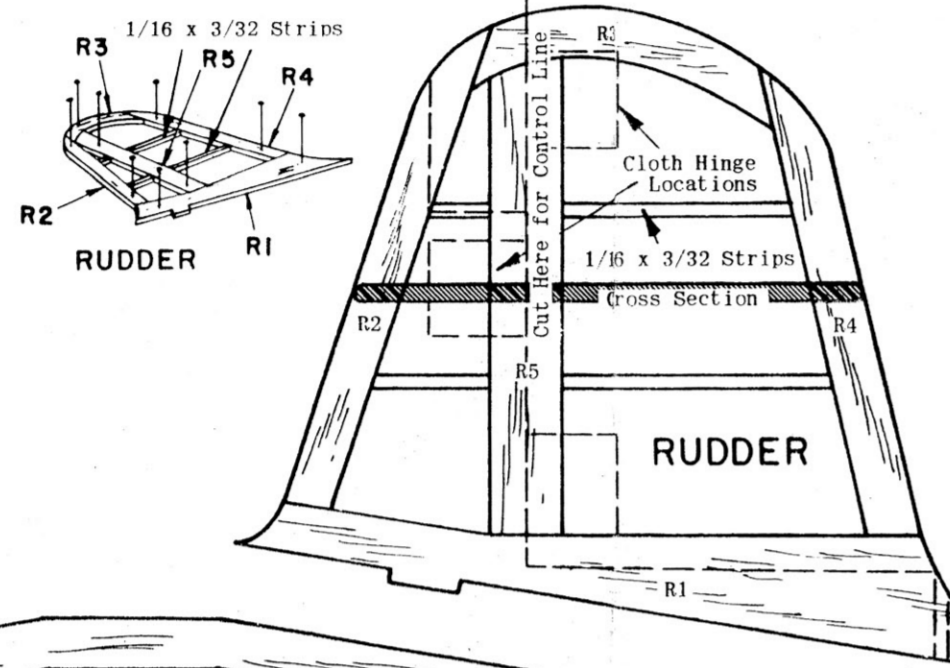

SILKSPAN TISSUE COVERING

The finest grade wet strength silkspan tissue provided in this kit permits covering of compound curves without wrinkling, when moistened with water before applying to frame. Tissue shrinks when dry to tight smooth surface. Use clear dope to attach tissue as follows: Apply a light coat to the outside edges of area to be covered. When dry, cut tissue to shape needed, about 1/4" over size. Place tissue on flat surface, and dampen with moistened cloth by dabbing. Apply a second coat of clear dope to outer edges, then place moistened tissue on frame. Pull tissue gently with fingers, working out all wrinkles. WHEN COVERING WING & TAIL SURFACES, PIN FRAMEWORK TO FLAT SURFACE TO PREVENT WARPS AS TISSUE DRIES. Cut out any wrinkled areas (bounded by nearest framework) and recover. Apply two or three coats of clear dope, thinned 50-50 with thinner, on wing and tail surfaces before assembling to model. COVER WING FIRST: Rocket firing mechanism, if used, must be installed as described in detail note before covering wing. On control line models, add about 1/2 ounce of weight to wing tip on outside of circle flown. Cover bottom of wing on both sides from W2 to tip, with one piece for each side. Leave center section uncovered. Cover top of gull section from W2 to W3 with one piece, likewise W3 to W4. Cover wing panels from W5 to W11 with one piece each side. Cover tips with separate pieces. COVER TAIL SURFACES NEXT: Cover both sides of rudder and stabilizer in one piece each. COVER FUSELAGE NEXT: Cover fuselage sides first with one piece from second stringer above side keel to bottom stringers at L5. Cover top back to F6 in one piece. Cover rear in two pieces from F8 back, joining in center on L2. After wing installation has been completed as described in Final Assembly, cover bottom from F1 to F3 in one piece. Cover from F3 to F7 in two pieces, joining over L7. Do likewise from F7 to rear, joining over L3. Apply four coats of thinned dope to tissue covering on fuselage. Check wings & tail surfaces for warps before assembly. Warps can be removed by holding over steam from boiling kettle) and twisting gently in opposite direction. Check again when cool.

WING ASSEMBLY

Build wing on flat surface directly on plan. Sketches show wing sections separated but this is just for clarity. Pin all WT parts in place, cementing to each other where they join. Cut 1/8 x 3/16 x 12 Main Spars & Leading Edges to proper length. Pin in place upright, cementing where they join WT's. Cut 1/8 x 3/16 short spar and pin in place upright.

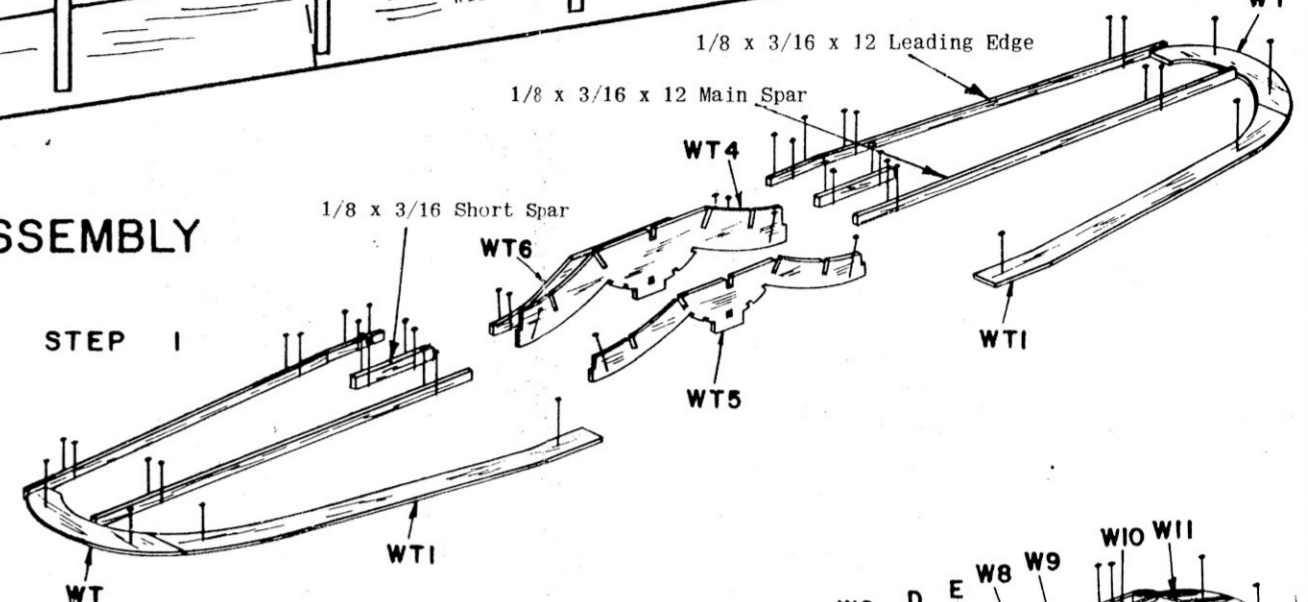

STEP 2

Ribs W1's to W11's are now cemented in place. Ribs W1, W2 & W3 have tabs on bottom. Ribs are pushed down into notches in WT4 & WT5 until tabs rest on flat surface as shown. Ribs W5's are angled using rib angle template (see detail) for dihedral angle shown in Step 3 Sketch. All other ribs are vertical. Complete leading edge of gull section by cementing J's against both sides of rib W1, against front of W2's & W3's, where it rests on front tabs. Cement 2 K's together, to make double layer, (make 2 units) and cement to front of W4 and J; flush with outside of W4 as shown. Cement 1/8 x 3/16 center leading edge against J's, from W2 to W2, resting on tabs. Complete trailing edge by cementing WT3 into notches in rear of ribs W1 & W2's as shown. Moisten WT2's to allow easy bending along short grain, and to prevent cracking. Insert and cement in rear of ribs W2, W3 & W4 as shown. Piece will automatically assume proper curve. Cement 1/16 sq spars into notches along top of ribs. Tips are beveled to fit on WT as shown. Cement A between W6 & W7, short spar fitting into notch. Cement B between W7 & W8, against rear of leading edge. Cement C between W7 & W8, against front of main spar which leaves a 1/16 space between B&C. Cement D & E vertically between W7 & W8 into notches. Trim leading edge to curve of tip. Allow frame to dry thoroughly before removing from flat surface.

STEP 3

Full pins out carefully and remove from flat surface. Separate wing panels and trim & sand leading edge to shape shown on wing cross-section. Round off tips & trailing edge as shown to blend smoothly into each other. Trim off leading edge, spars & trailing edge; flush to angled rib W5's. Pin center panel to flat surface. Cement outer panels in place, blocking up tips, on both sides, 1-1/8" for proper dihedral angle. Use cement generously and allow to dry thoroughly. Completed wing frame is now removed from flat surface and landing gear installation, as shown on Final Assembly Sketch, is now made. Cement landing gear support ribs W4A to inner side of ribs W4. FLUSH WITH TOP. Landing gears are now securely cemented in place as shown. Top of gear rests against bottom of W4A. Rear is tied securely to spar with thread as shown on sketch & wing plan. Axles face outward toward tips. Landing gear is locked in place by cementing G against W4 and bottom of horizontal section of gear. When installation is complete, apply a second heavy coat of cement and allow to dry thoroughly. When dry, remove rib tabs and sand frame smooth to prepare for tissue covering.

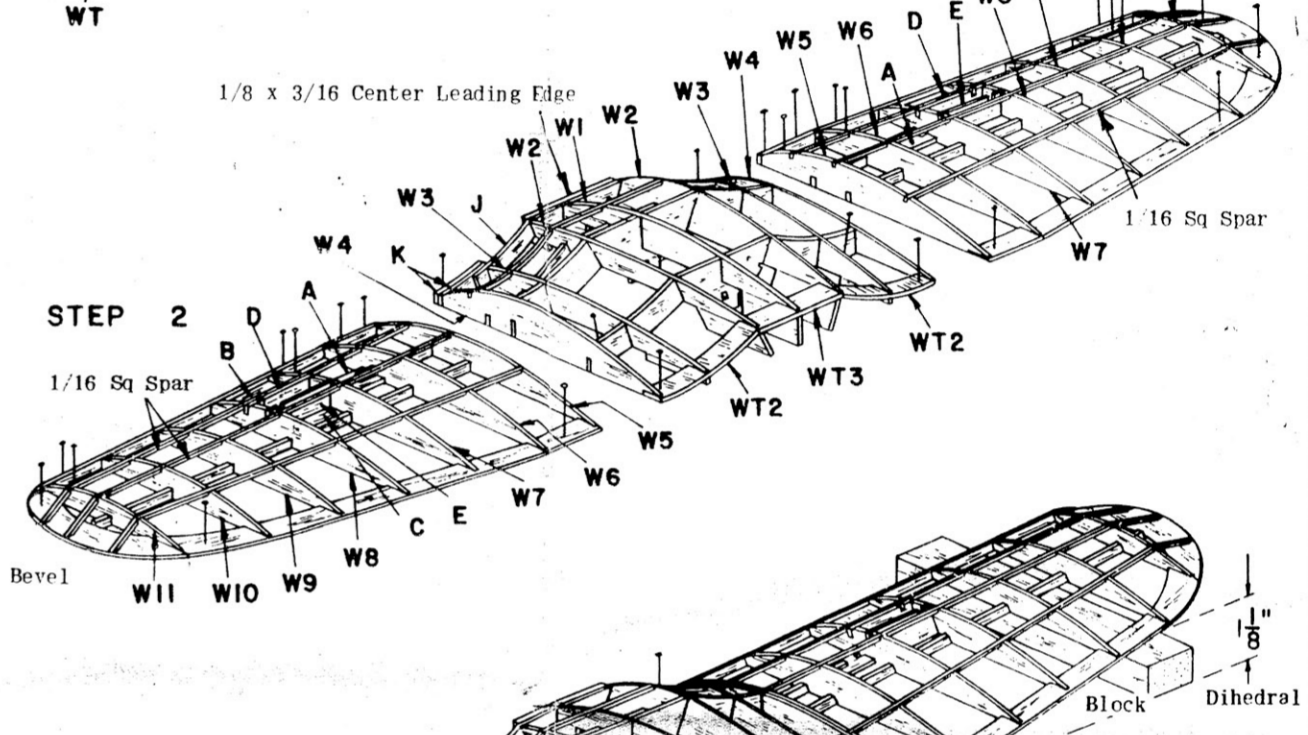

STEP 3

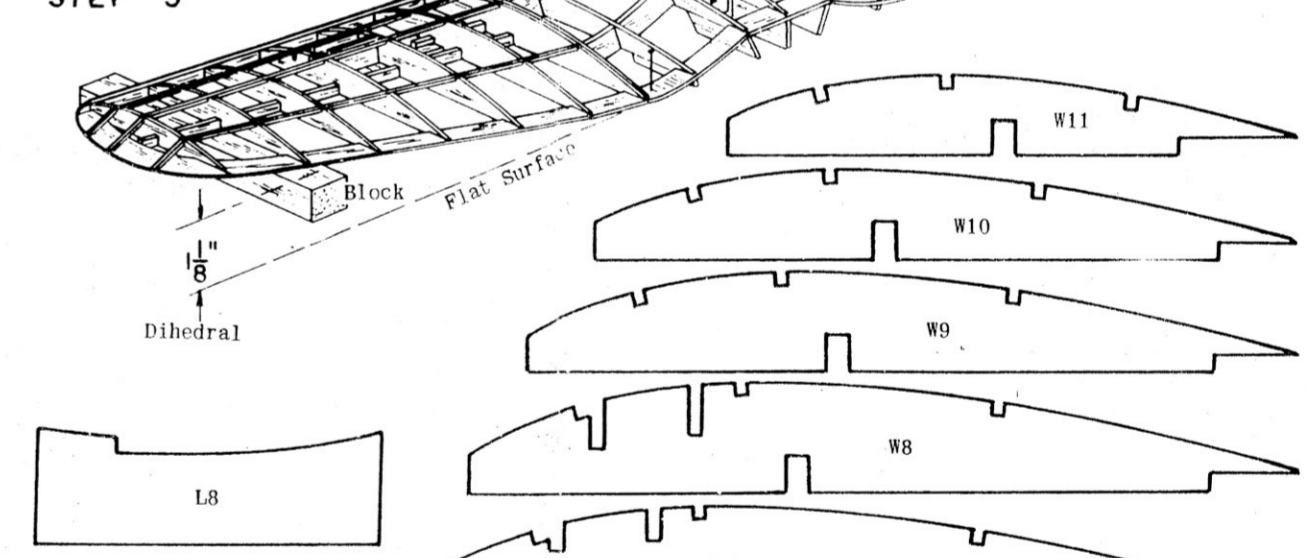

FUSELAGE ASSEMBLY

COWL FRAME DETAIL
Make two cowl frames directly on plan. Use 1/16 x 3/32 strips cut to fit. Cement between F1 and rear of cowl adjoining hole for nose button in final assembly.

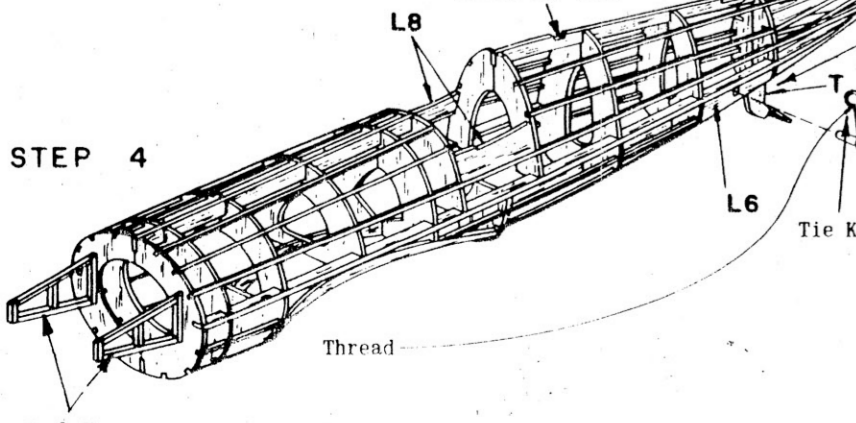
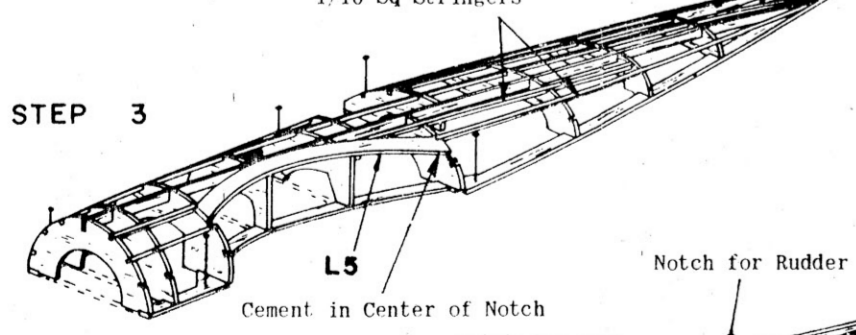
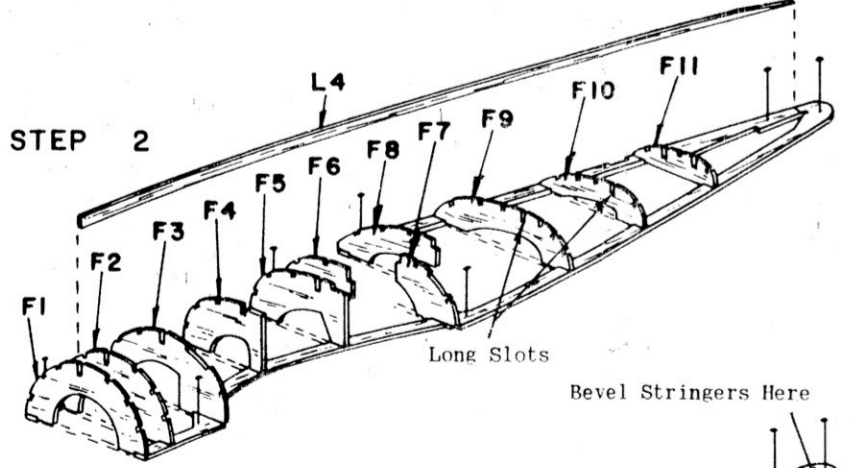
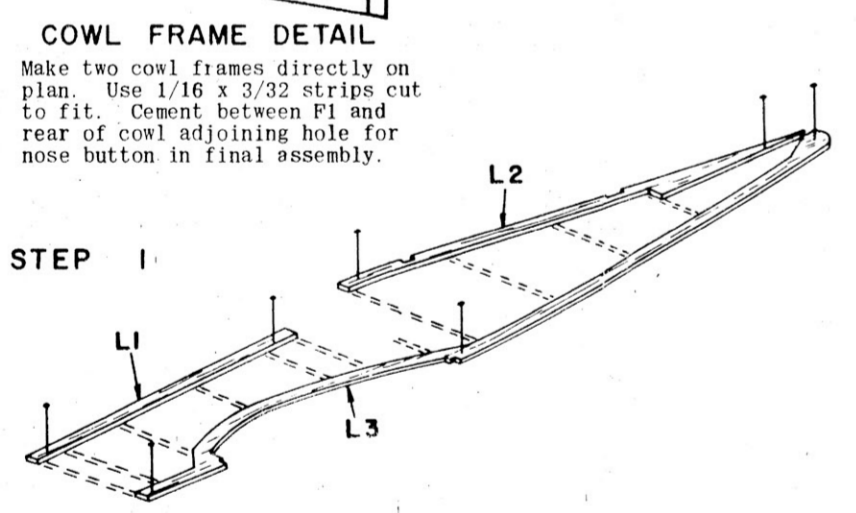

STEP 1
Fuselage construction is started on flat surface directly over plan. Pin all L parts in place as shown.

STEP 2
Cement all bulkhead halves from F1 to F11 vertically to frame as shown, then add L4, which is inserted into long slots in center of bulkheads.

STEP 3
Pin and cement side keel L5 into notches in corners from F3 to F7. Front and rear of L5 is cemented into center of notch in F3 & F7 to provide 1/16 space for stringer above and below it. Install all stringers, which are 1/16 sq into their respective notches; except for the two lower ones between F1 & F3, and the bottom one between F7 & F10, as shown on sketch. Top stringers not visible, can be seen in next sketch. Bevel ends to fit at rear. Allow frame to dry thoroughly to prevent warping or twisting. Over night is recommended. Assembly of wing or tail surfaces can be started in the meantime.

STEP 4
Carefully pull out pins and remove frame from flat surface, then cement opposite halves of bulkheads in place, followed by L4. Add 1/16 sq stringers in same manner then cement L6's & L7's to both sides of fuselage flush with outside of frame as shown. Install spring rear hook (omit on gas powered models) by inserting a 1-1/8 length of 1/8 dowel thru coils of rear hook. Insert & cement ends of dowel between L6's. Securely cement straight end of hook to bottom of side keel L4. Only straight end of hook is fastened, leaving coil free for spring movement. Straighten top of tail wheel gear and bend 1/8 spur as shown on side view. Sink spur into rear of F11 and cement securely in place. Cement T against left side of tail gear and fuselage in position shown on side view. Cement S into notches in F11 in front and L3 in rear. Stringers omitted in Step 3 are still not installed until after wing is mounted, as described in Final Assembly. Cowl frames (used on rubber powered models) are shown installed on F1. They are shown for clarity only. Install as described in Final Assembly Note. Allow fuselage frame to dry thoroughly, then sand lightly to present a smooth surface for tissue covering, described in detail note. If model is constructed other than for rubber power, see respective notes, (Control Line, Radio, etc.) before covering fuselage.

DIE CUT PART NOTE
All die cut parts used in construction are given full size either on full size plan or individual layout. This will enable you to duplicate any part should it become necessary for any reason. Die cut parts contained in sheet as furnished in kit are also available from the factory as replacements.

