

Peter Rake's
Waco SRE
Copyright P. Rake 2015

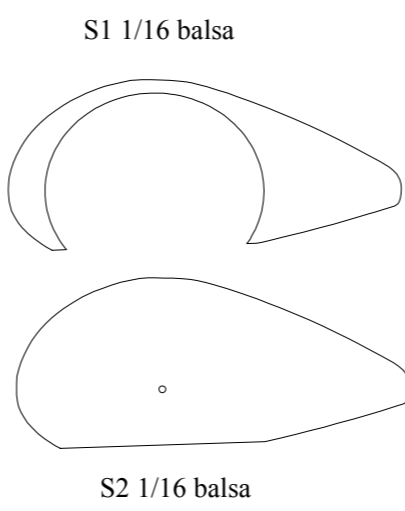

equipment shown
Vapor Rx brick
PZ 8.5mm motor unit

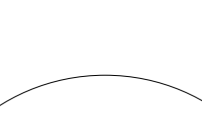
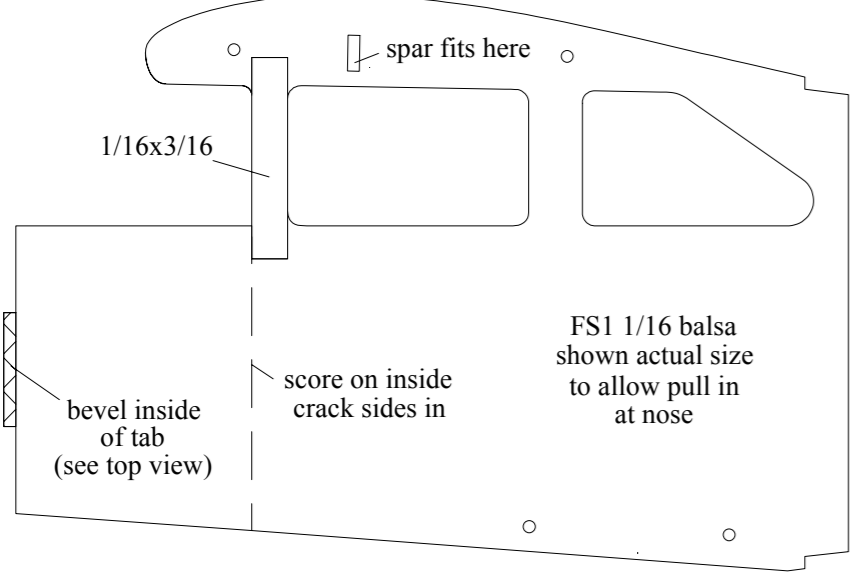
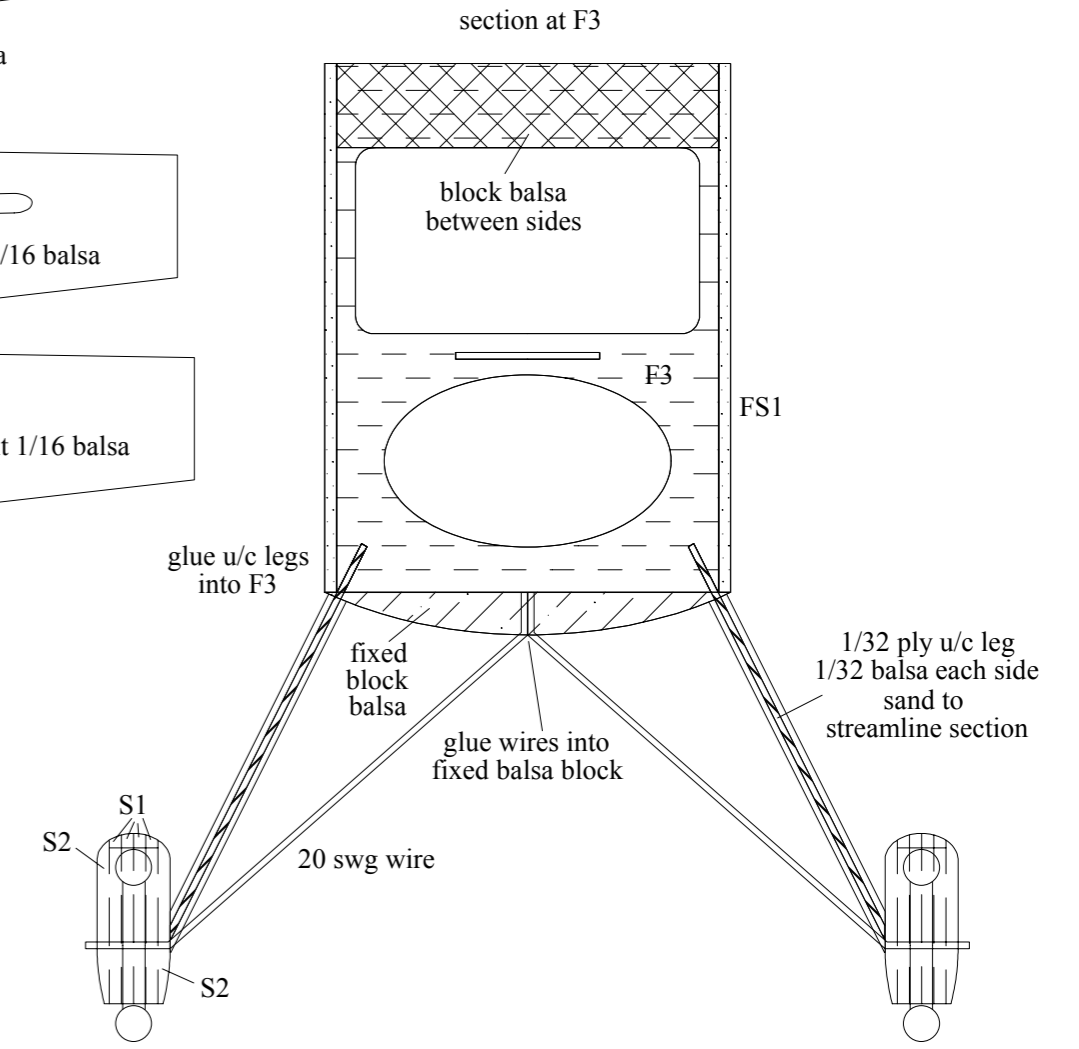
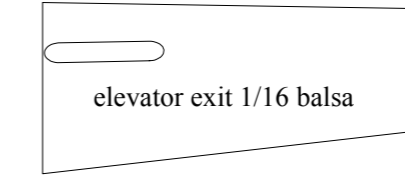
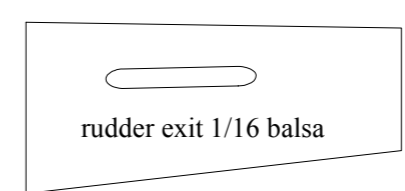
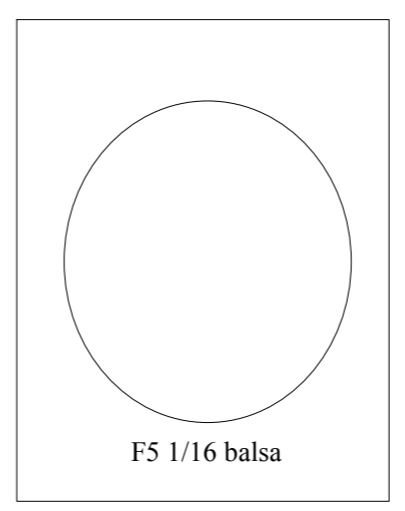
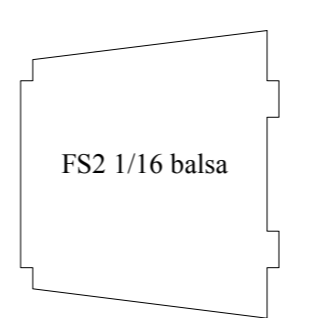
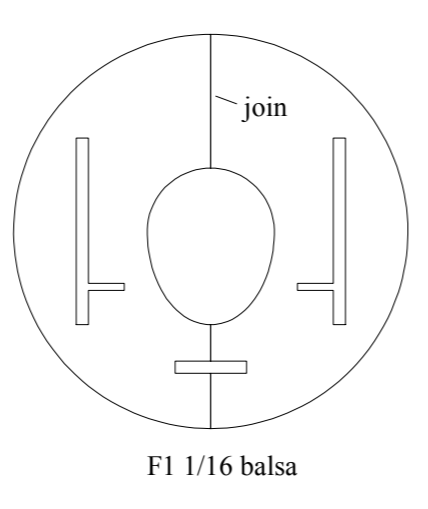
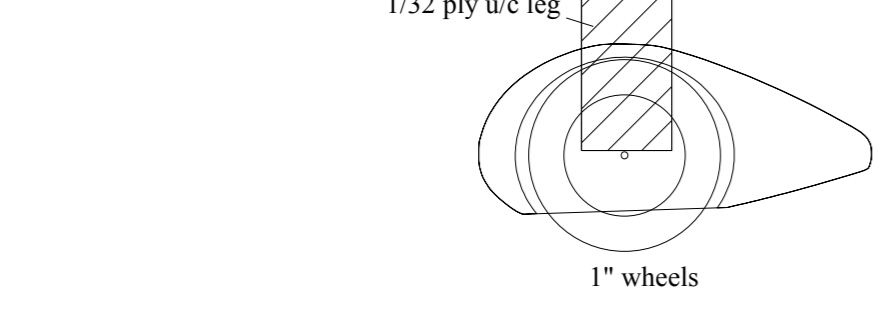
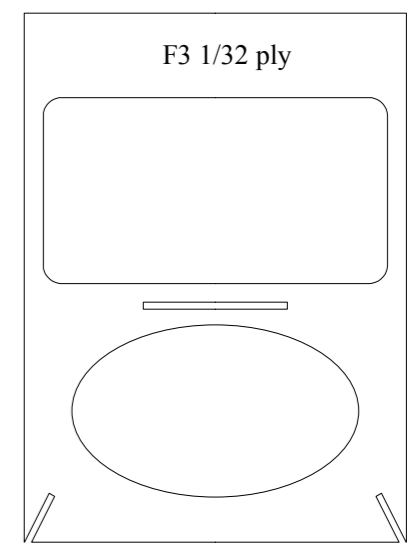
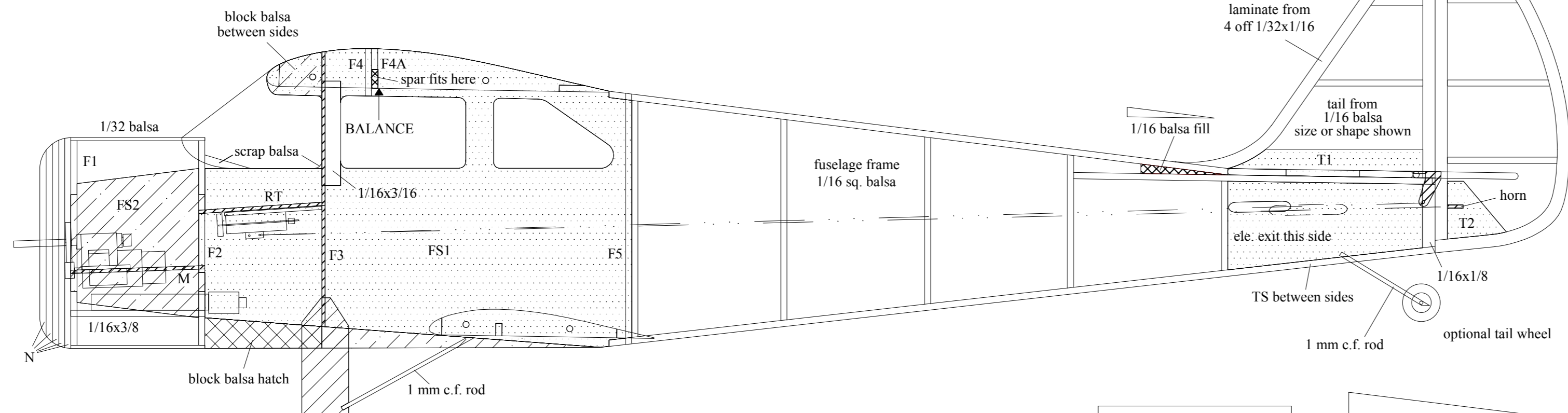
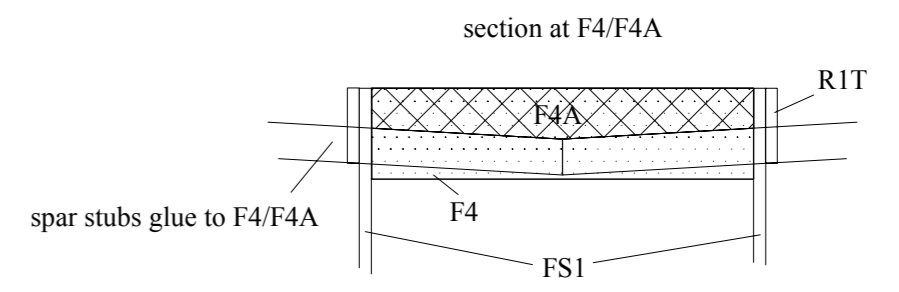
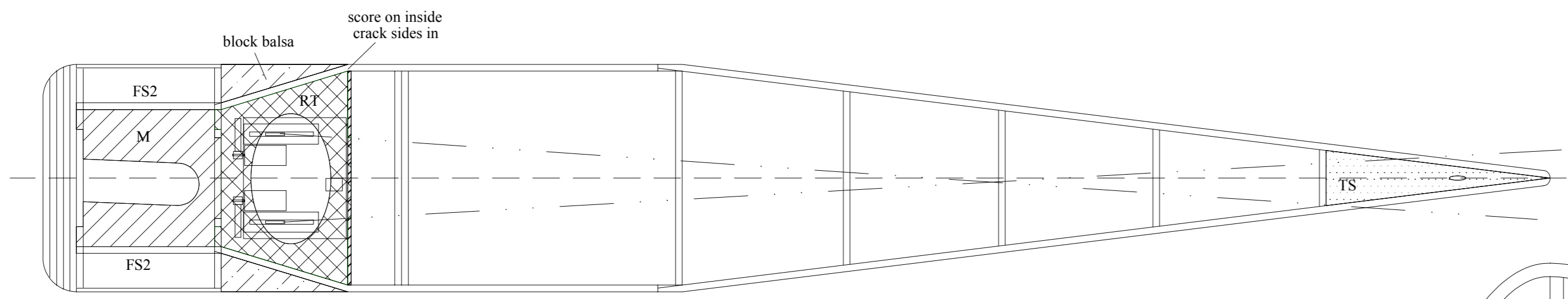
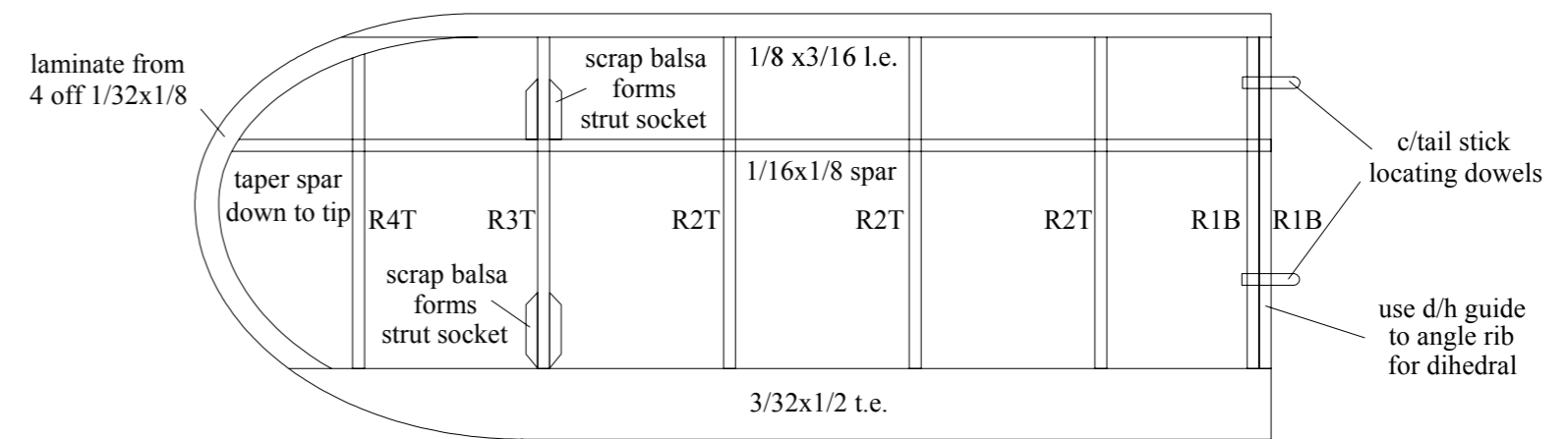
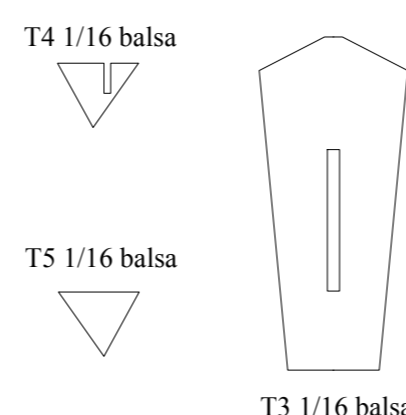
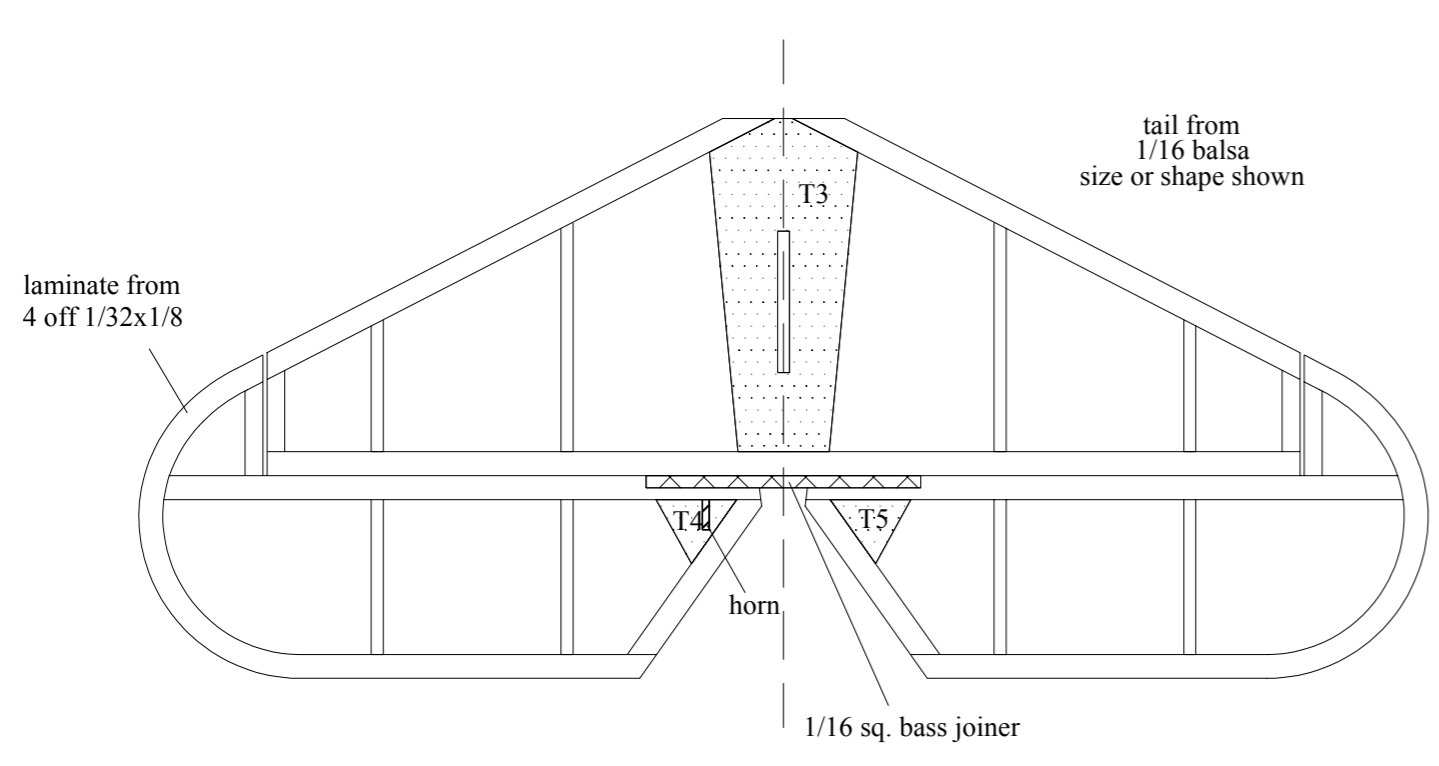
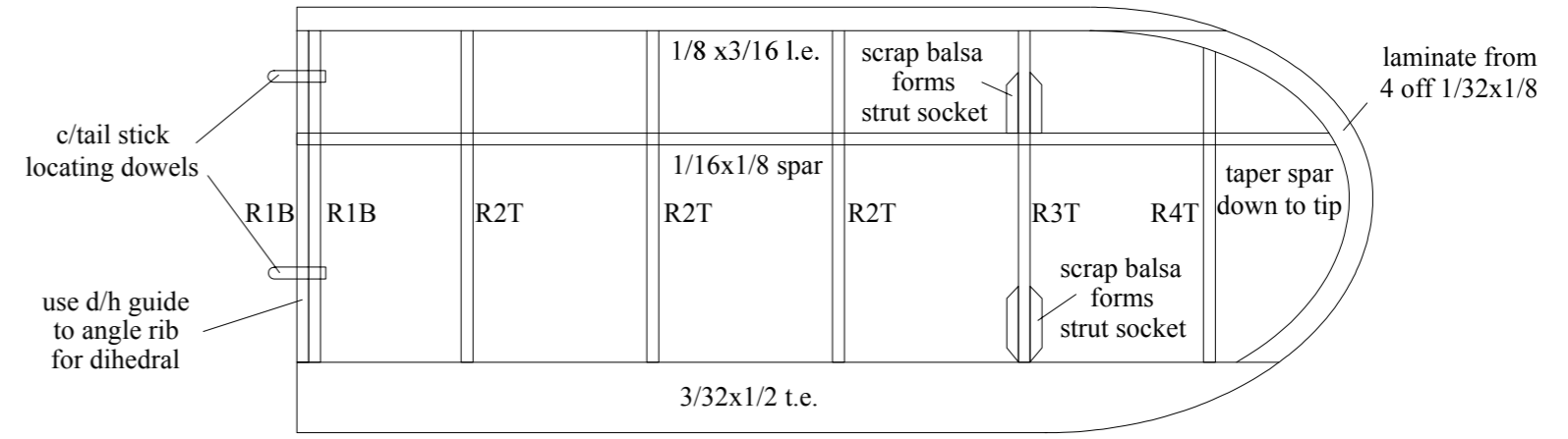
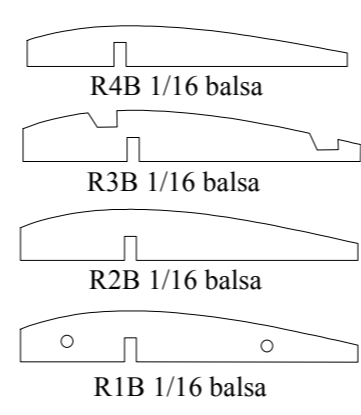
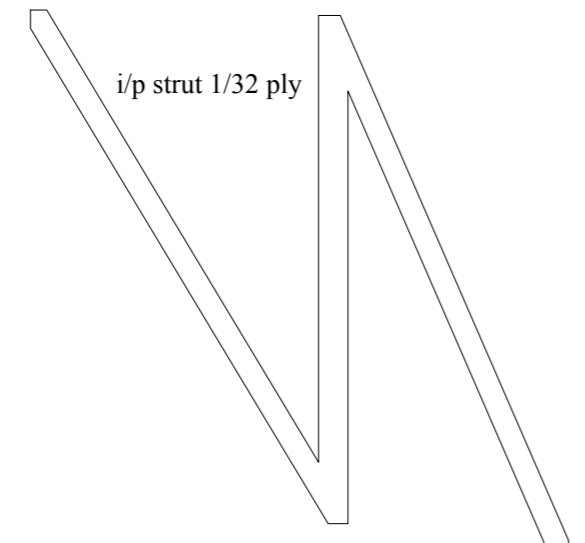
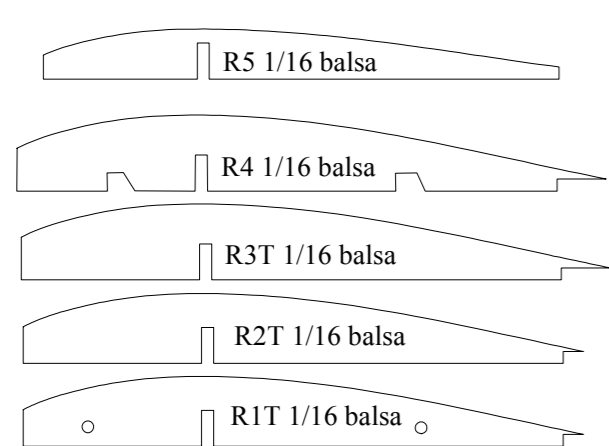
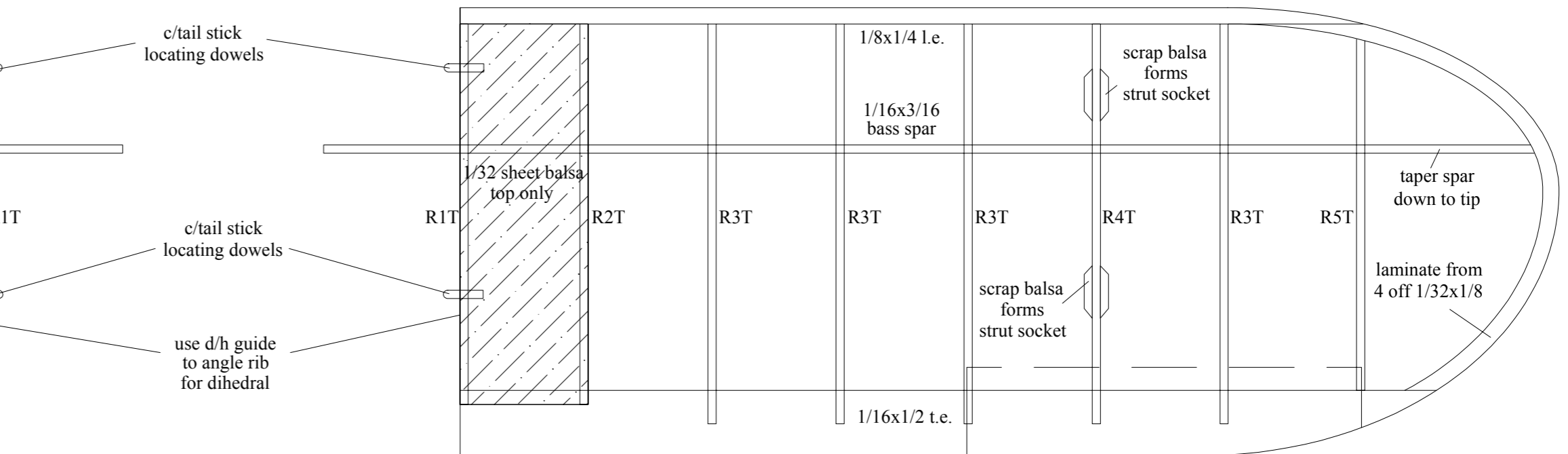
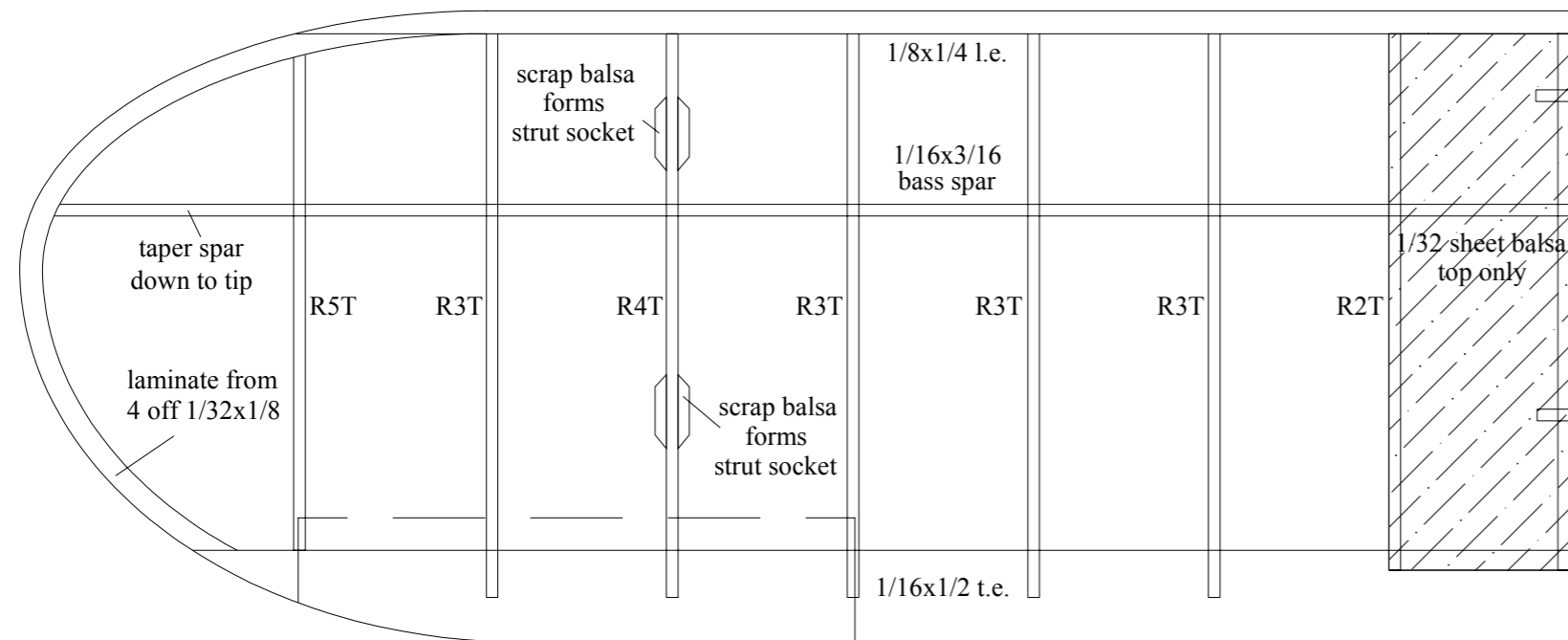
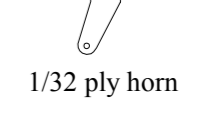
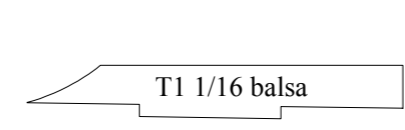
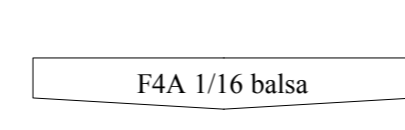
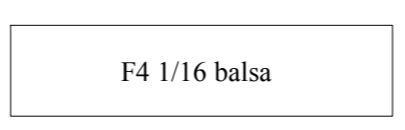
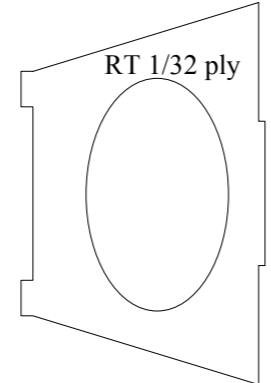
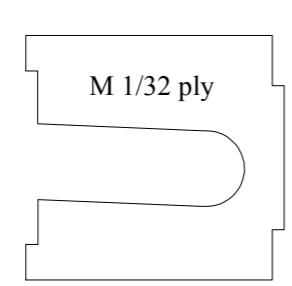
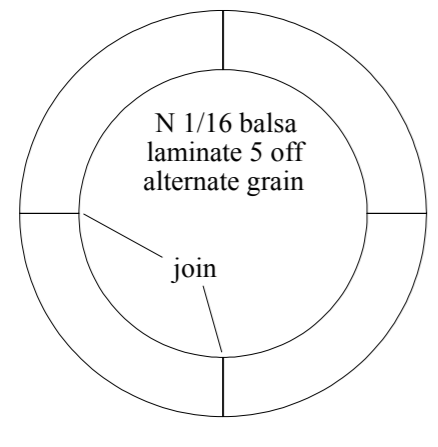

1/16 balsa

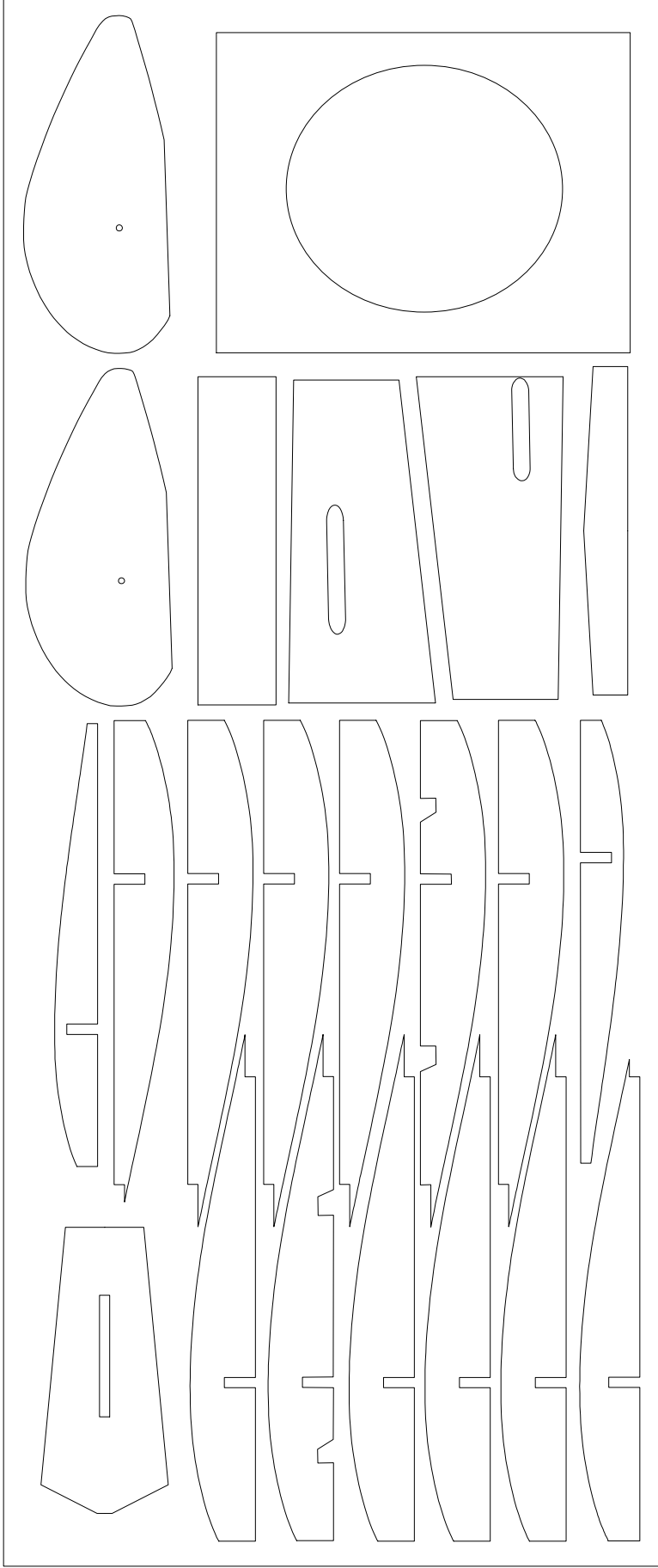

1/32 ply

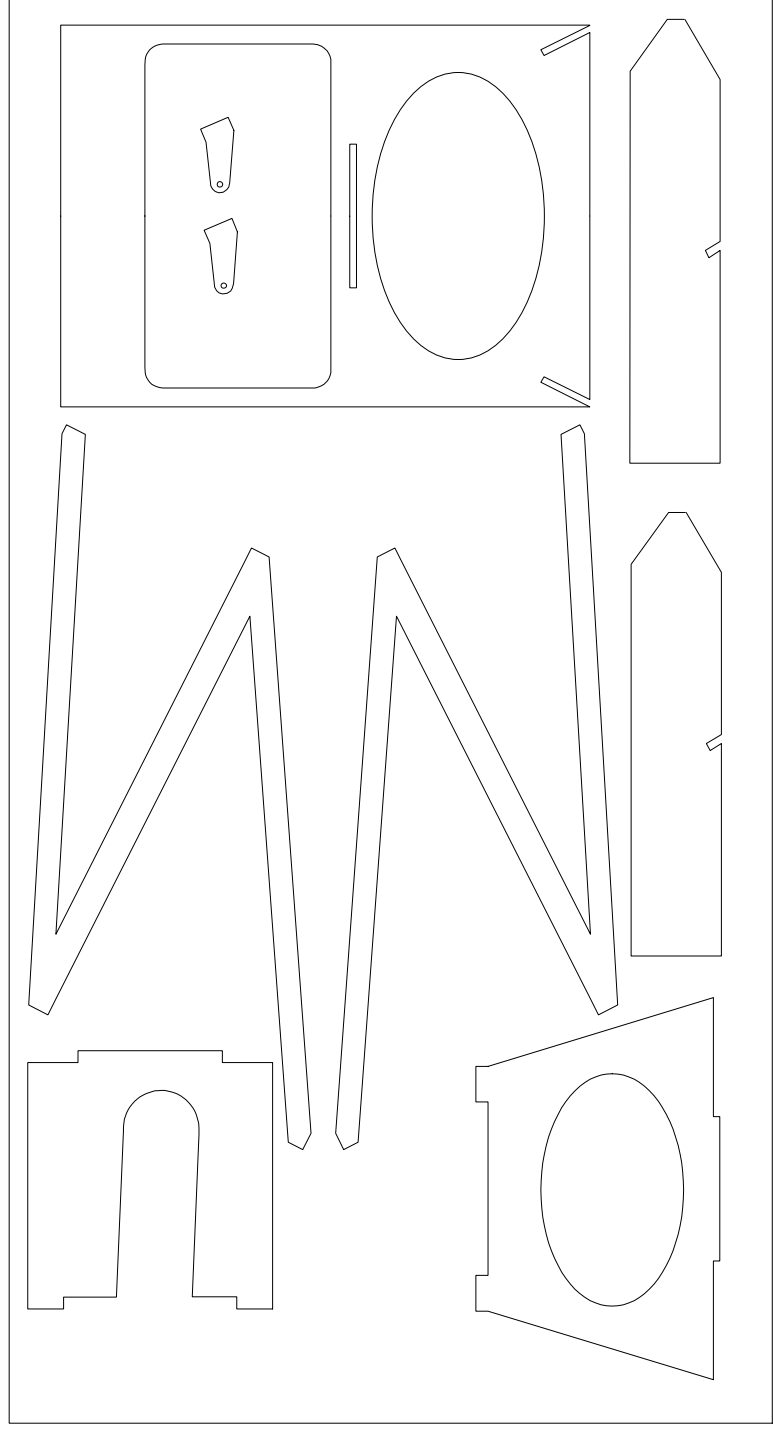

1/16 balsa

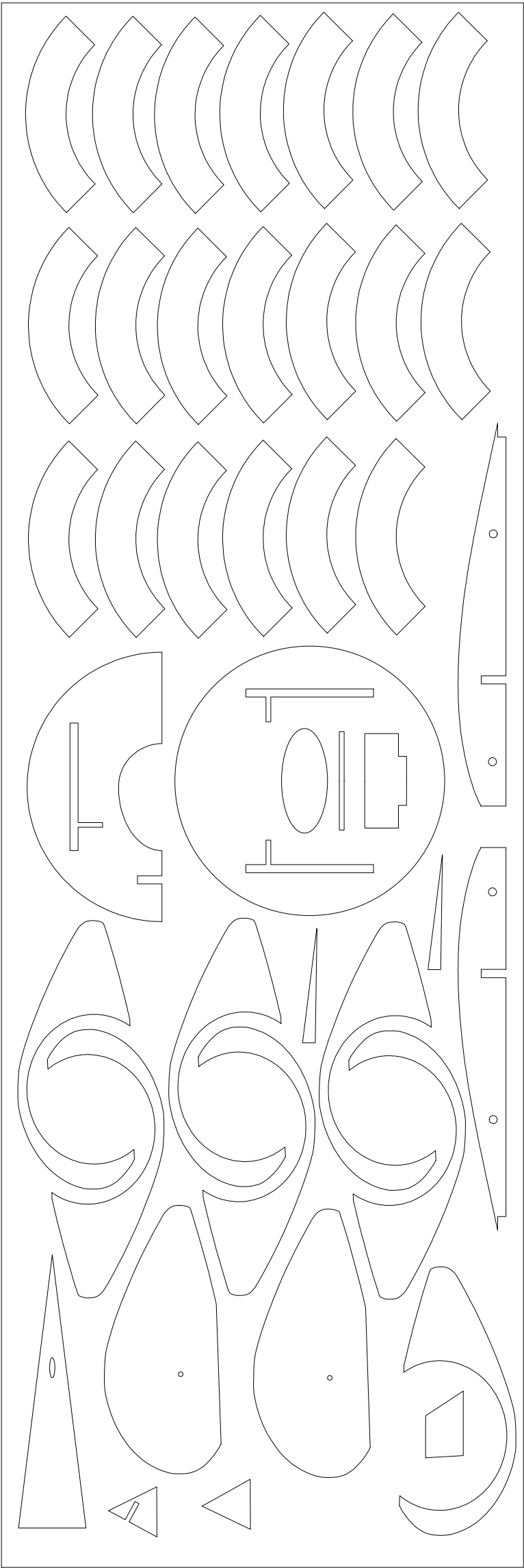

1/16 balsa

