

1/32 ply gun ring

equipment shown  
Vapor Rx brick  
PZ 8.5mm motor unit

# Peter Rake's Bristol F2B 'Fighter'

Copyright P. Rake 2015

scrap balsa  
covering 'land'  
around skid post  
bottom only

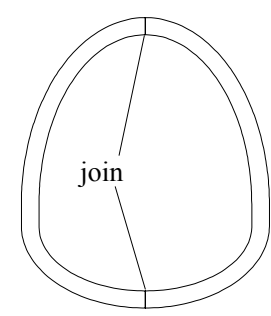

N1 1/16 balsa

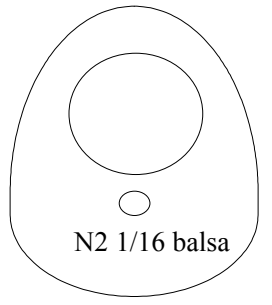

N2 1/16 balsa

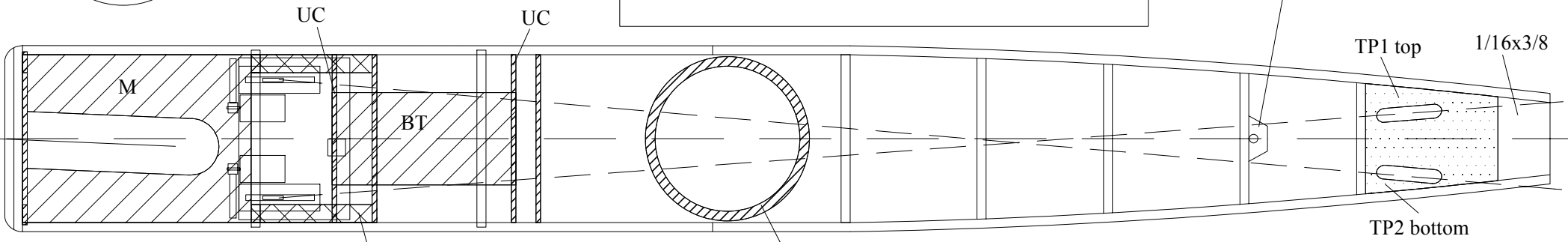

1/16x1/8 balsa  
receiver rails

1/32 ply gun ring

TP1 top  
1/16x3/8

TP2 bottom



F5 1/16 balsa

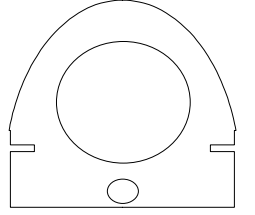

F1 1/32 ply

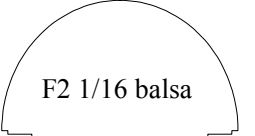

F2 1/16 balsa

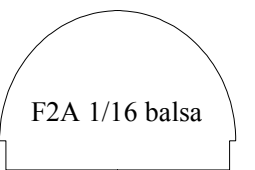

F2A 1/16 balsa

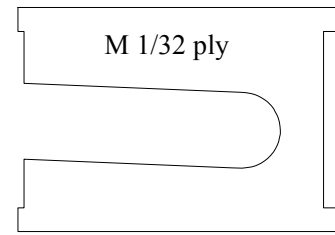

M 1/32 ply

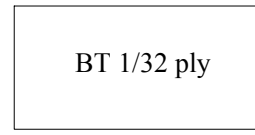

BT 1/32 ply

CST1 1/16 bass

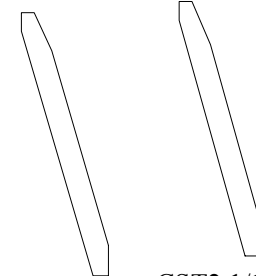

CST2 1/16 bass

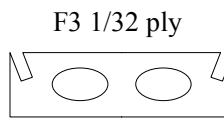

F3 1/32 ply

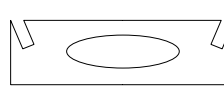

F4 1/32 ply

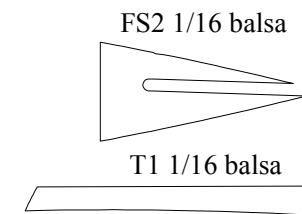

FS2 1/16 balsa

T1 1/16 balsa

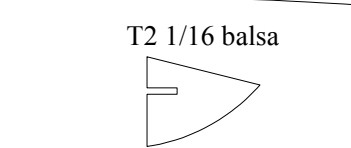

T2 1/16 balsa

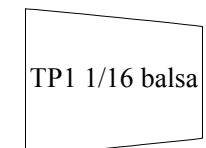

TP1 1/16 balsa

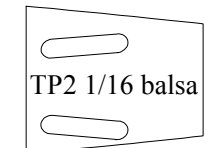

TP2 1/16 balsa

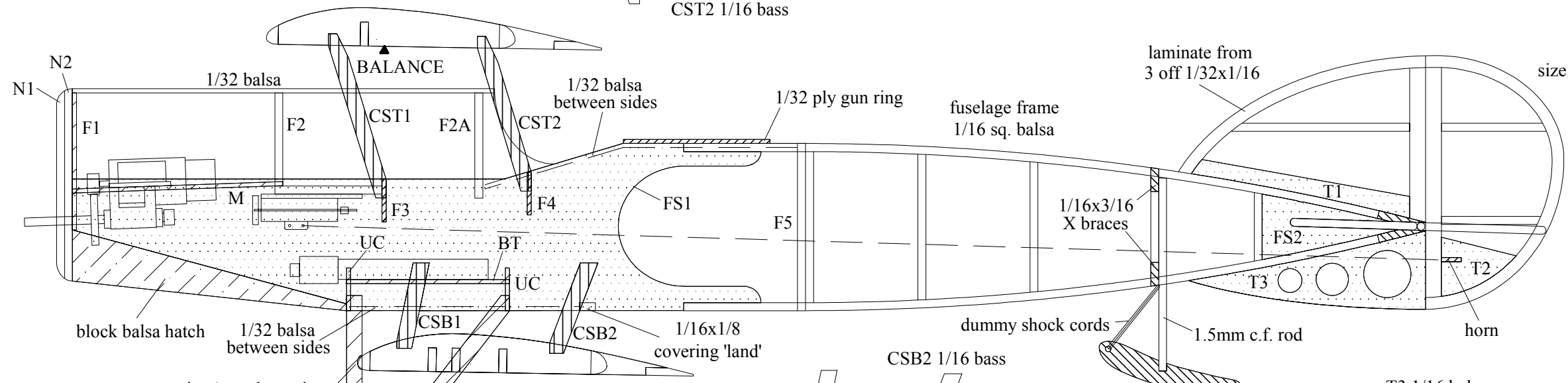

laminated from  
3 off 1/32x1/16

tail from  
1/16 balsa  
size or shape shown

rear i/p struts  
1/16 bass

front i/p struts  
1/16 bass

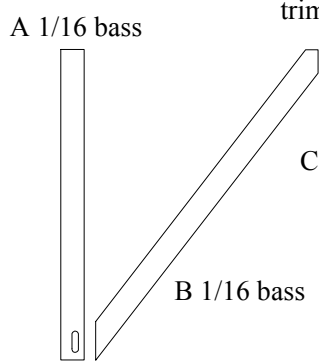

A 1/16 bass

trim A to clear wing

C 1/32 ply

B 1/16 bass

1.25" wheels

u/c shown actual size  
assemble over drawing  
glue into parts UC  
after lower wing is in place  
glue axle into slots

to aid final assembly  
use assembled u/c as a guide  
for fitting 1/32 balsa fill  
remove u/c & cover lower fuselage  
before fitting bottom wing

CSB1 1/16 bass

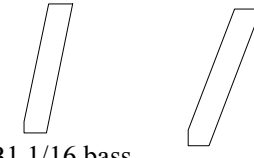

CSB2 1/16 bass

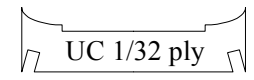

UC 1/32 ply

1/16 bass skid

1/16 bass skid

1/16 bass skid

horn 1/32 ply

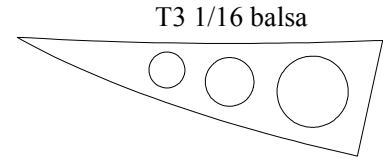

T3 1/16 balsa

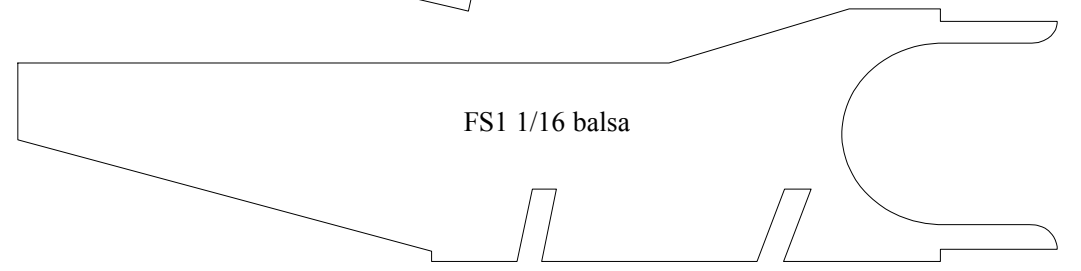

FS1 1/16 balsa

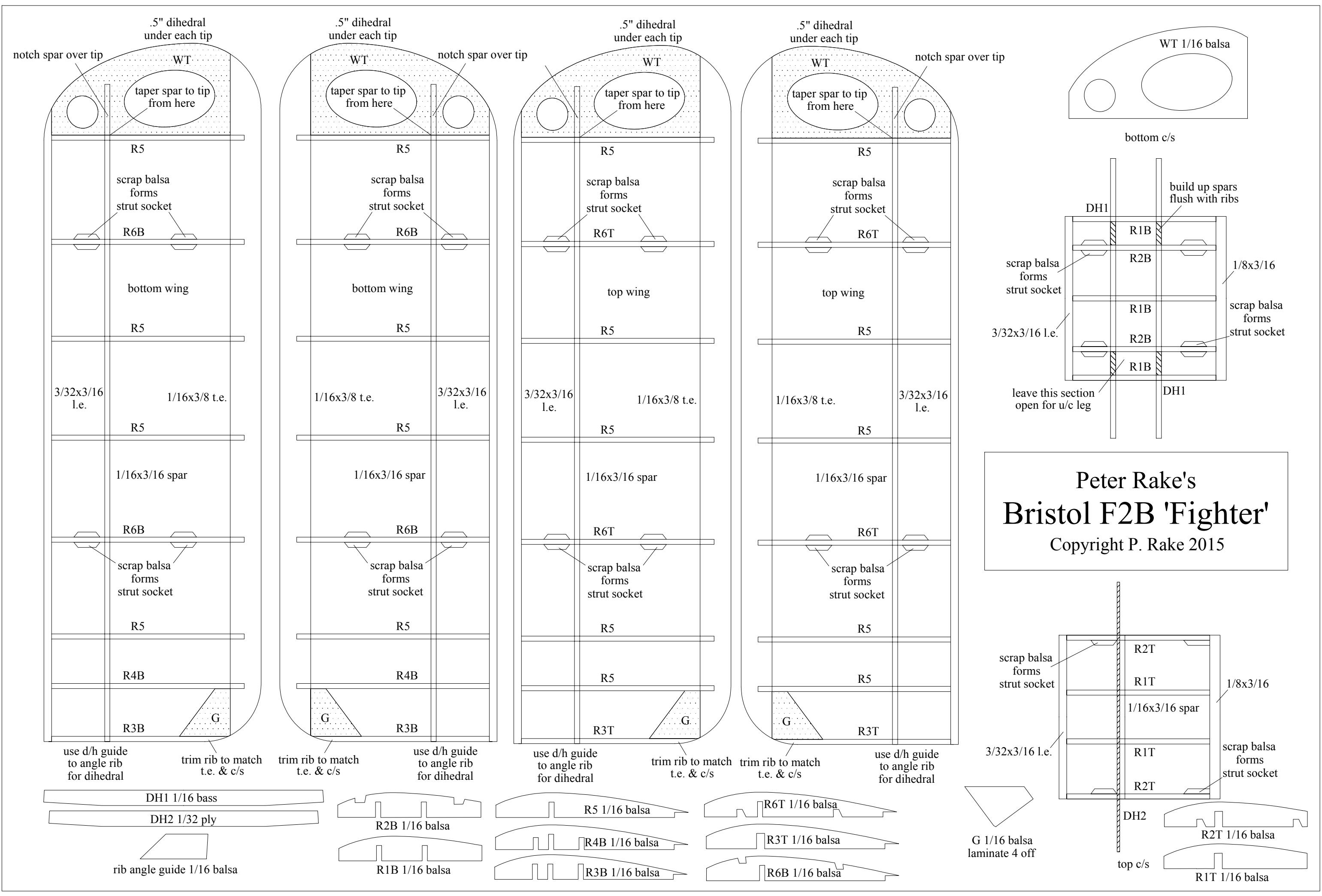

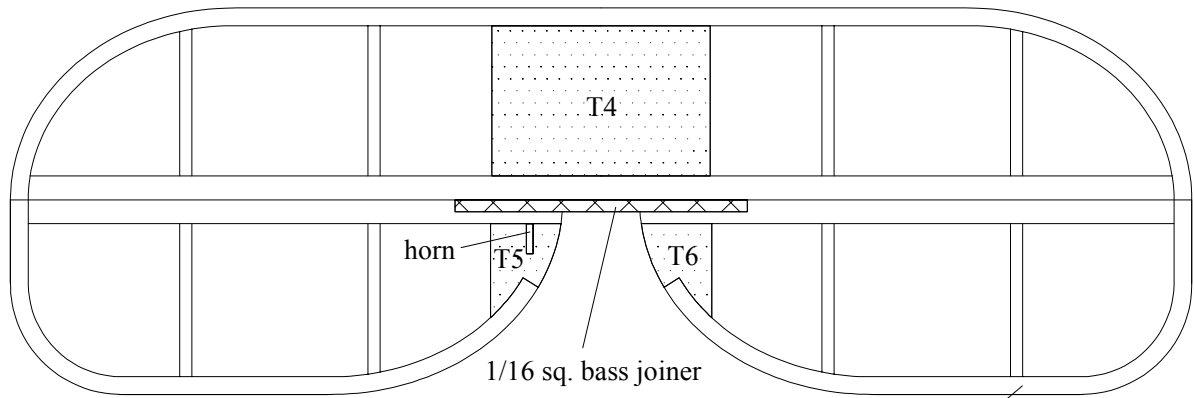

tail from  
1/16 balsa  
size or shape shown

laminate from  
3 off 1/32x1/16

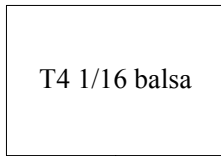

T4 1/16 balsa

T5 1/16 balsa



T6 1/16 balsa

bevel ends as shown  
to fit strut sockets

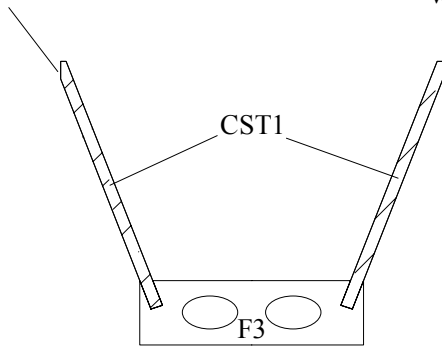

CST1

F3

pack up strut ends  
as shown in side view  
with formers flat to board

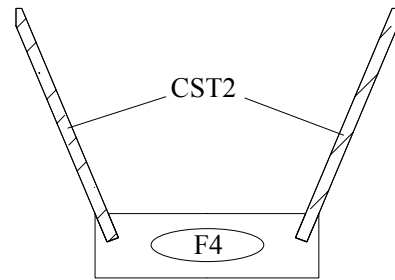

CST2

F4

bevel ends as shown  
to fit strut sockets

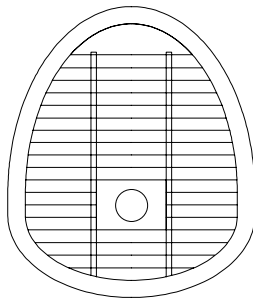

optional radiator detail  
make from thin ply  
or plastic sheet

Peter Rake's  
**Bristol F2B 'Fighter'**  
Copyright P. Rake 2015