

**Peter Rake's  
Aeronca Defender**  
Copyright P. Rake 2015

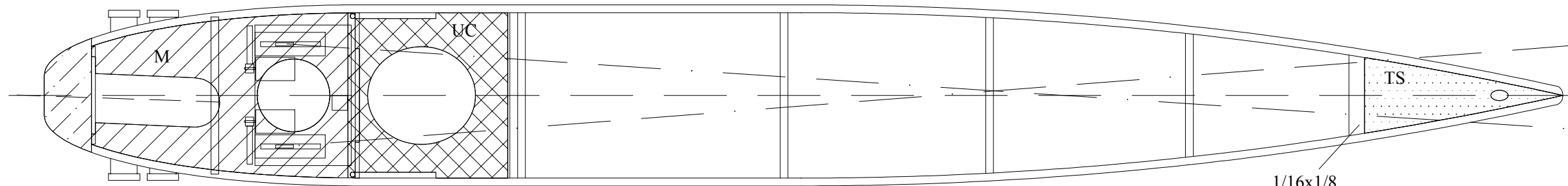

2 cylinders each side

1/16x1/8 laminate from 3 off 1/32x1/16 balsa

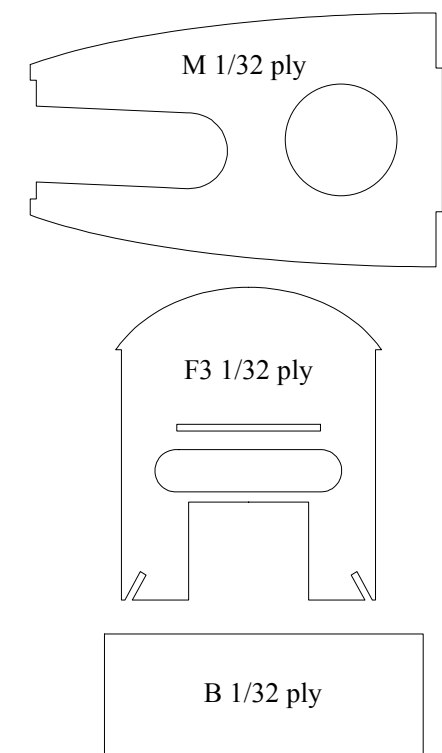
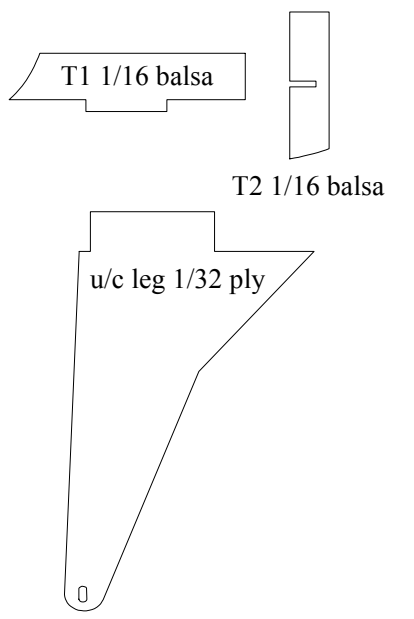
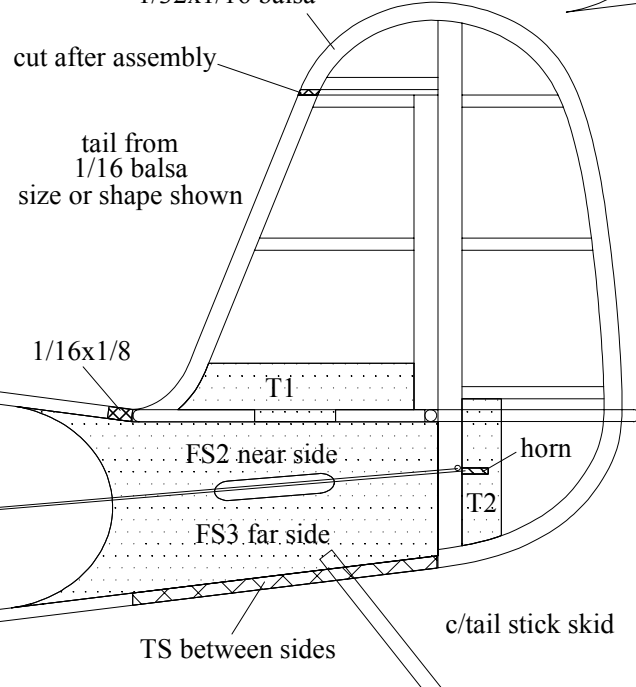
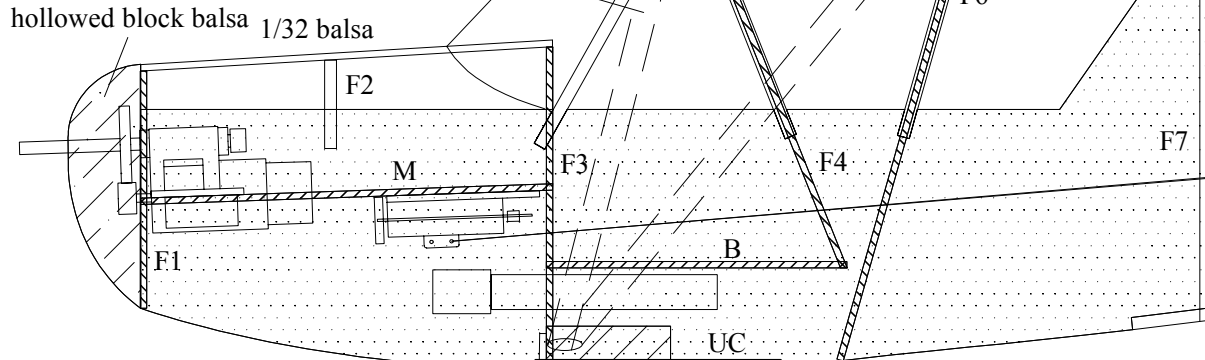
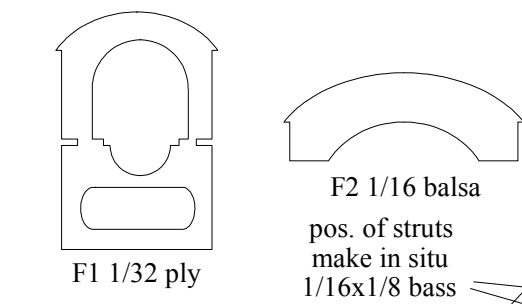
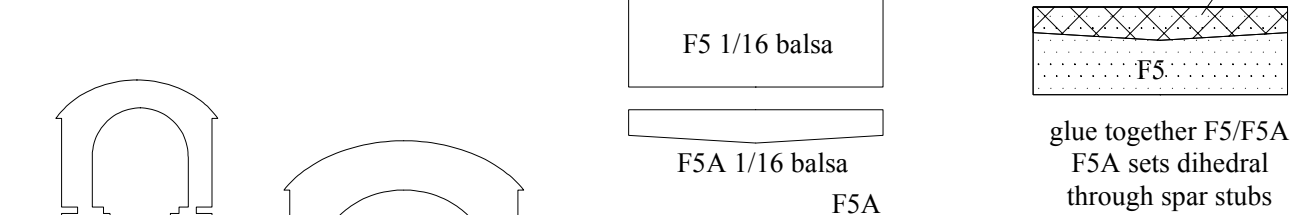
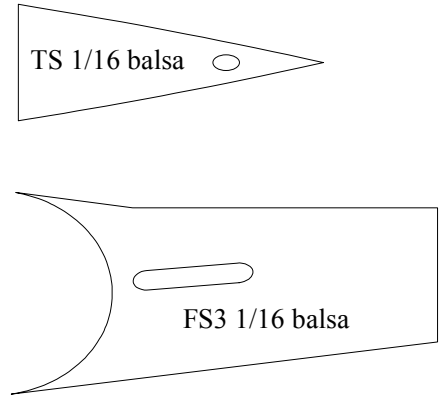

u/c shown actual size glue legs into UC/F3 spring in main wire glue in place top wire bind & solder

equipment shown Vapor Rx brick PZ 8.5mm motor unit

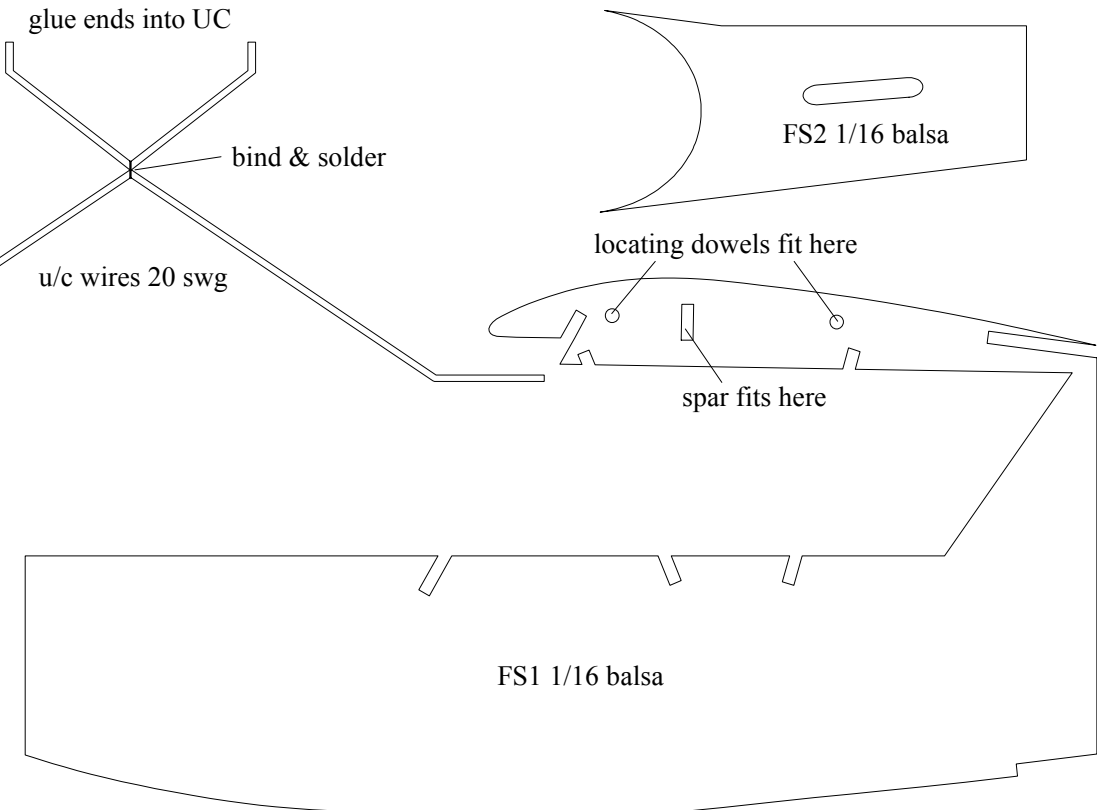
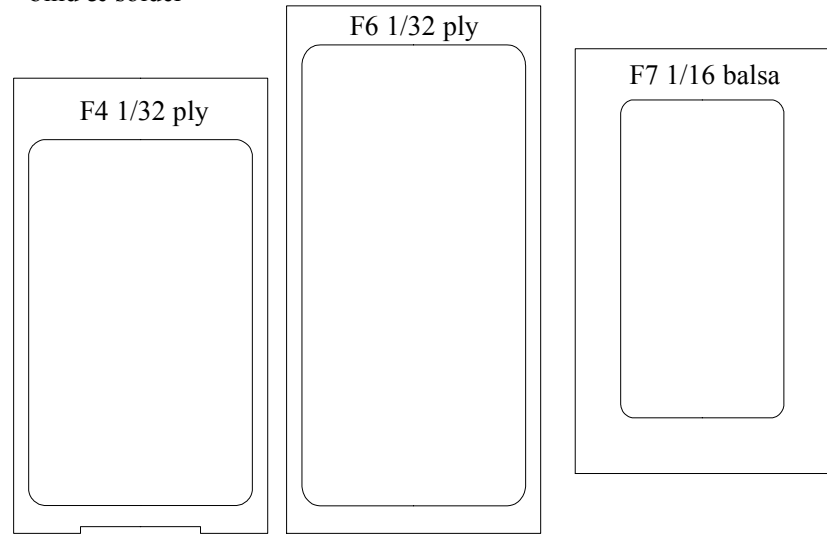
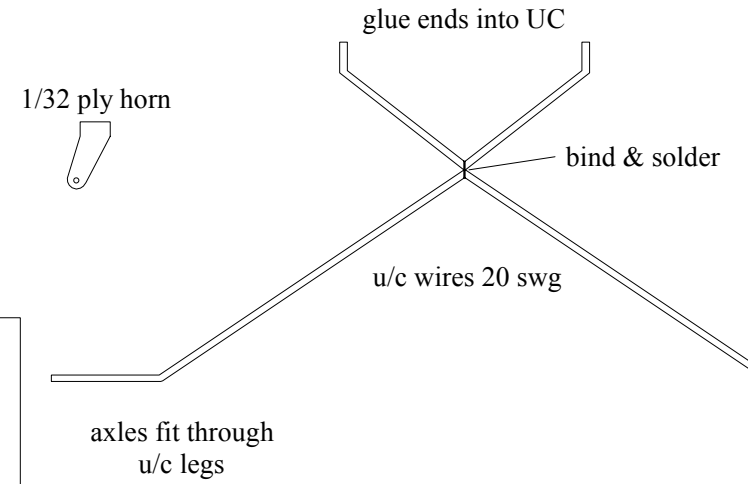

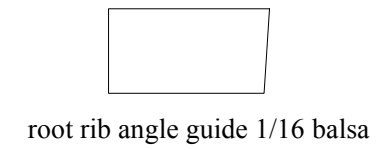
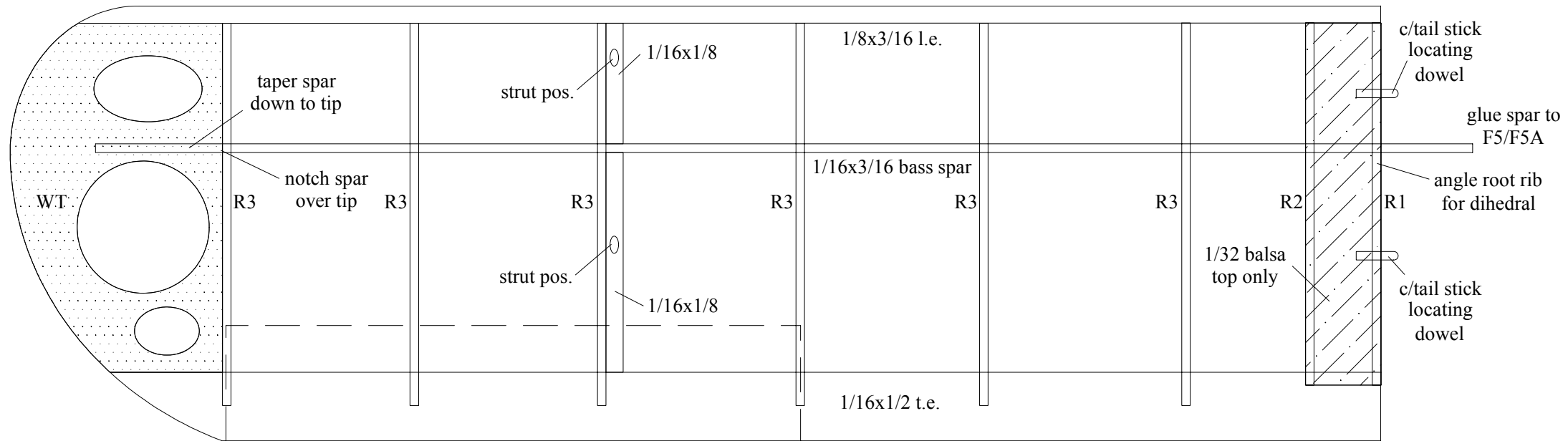

Peter Rake's  
**Aeronca Defender**  
 Copyright P. Rake 2015

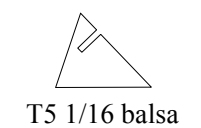
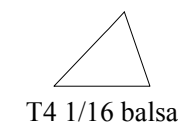
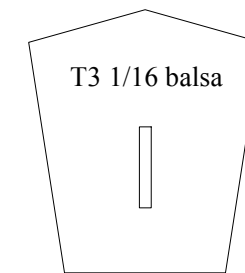
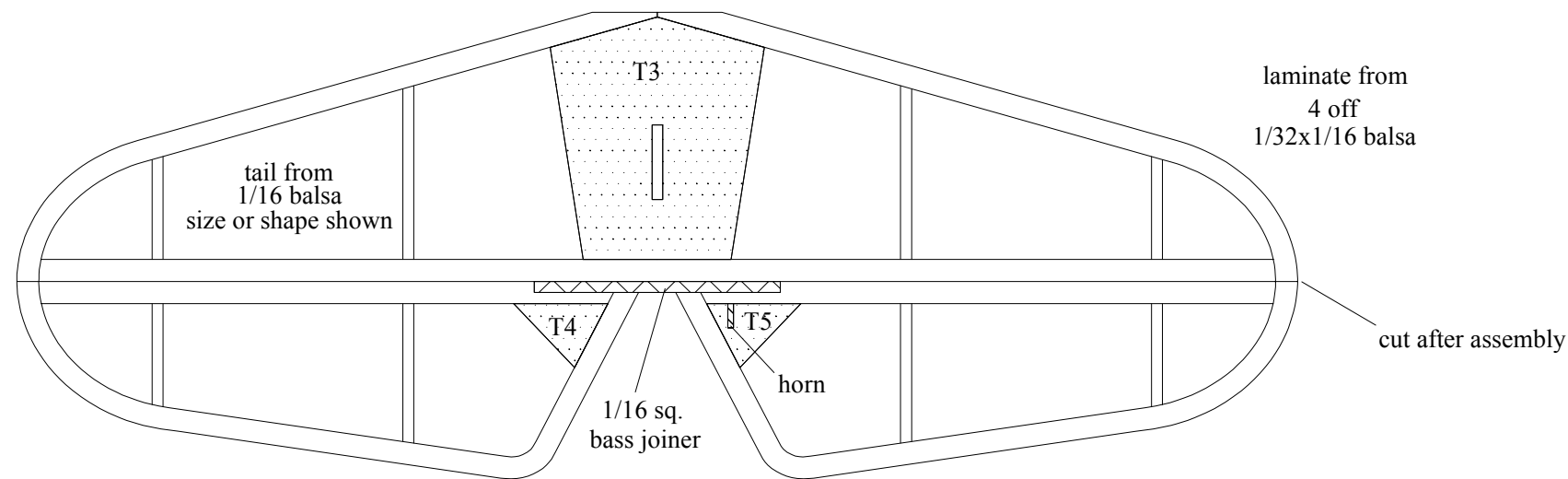
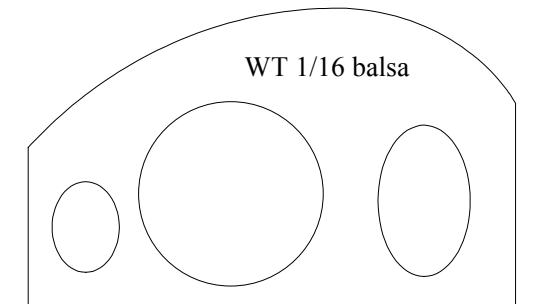
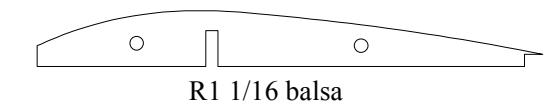
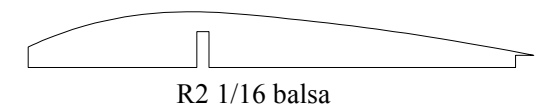
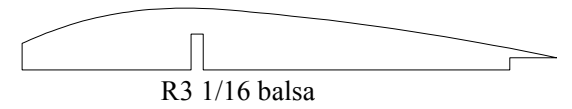
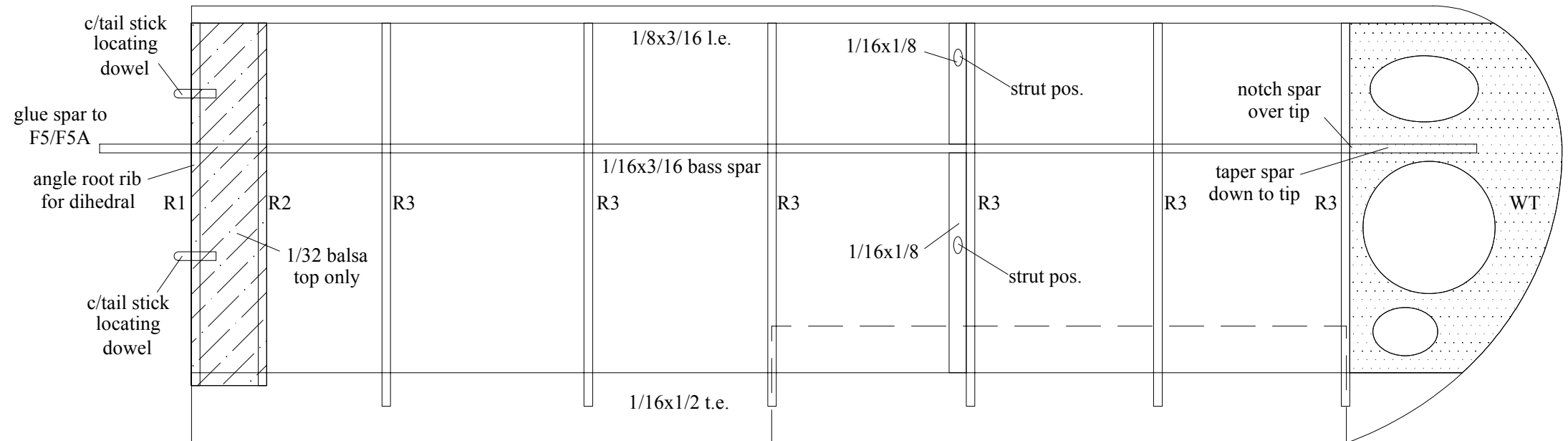

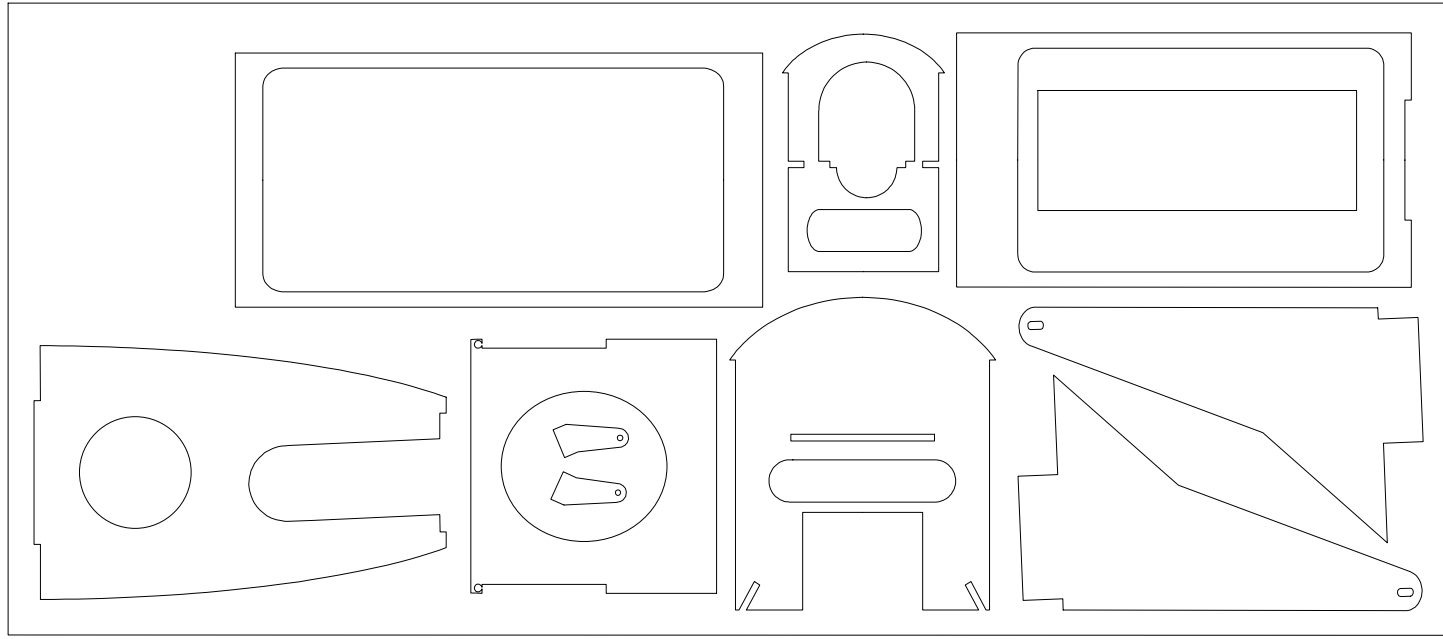

1/32 ply

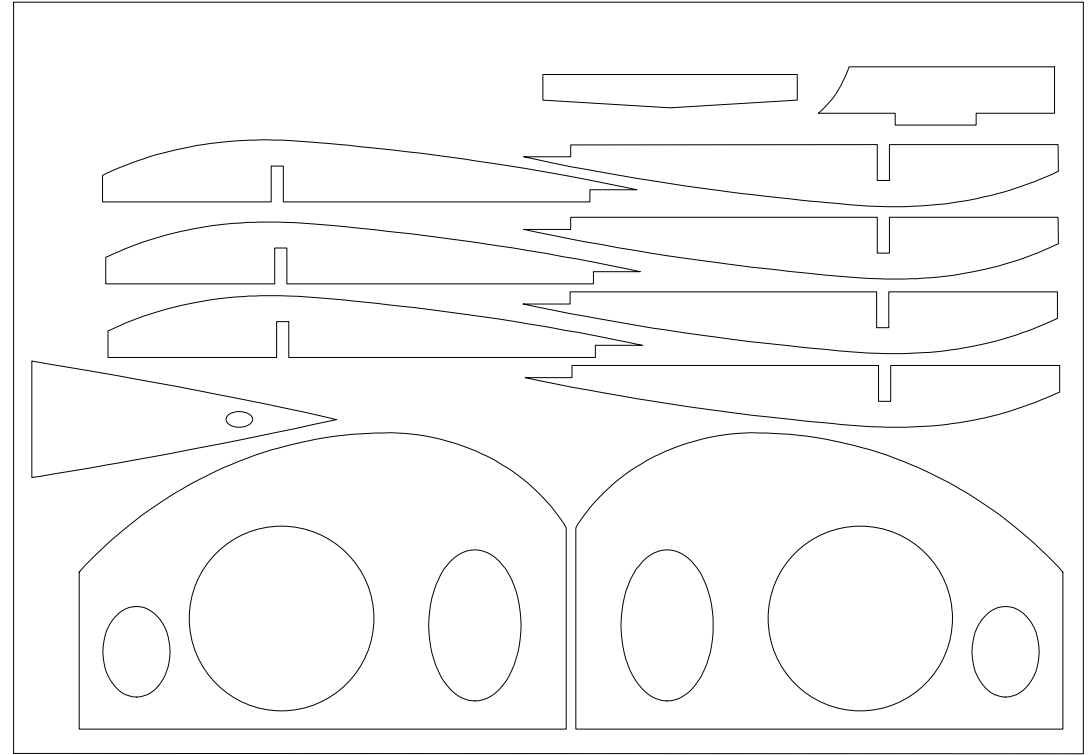

1/16 balsa

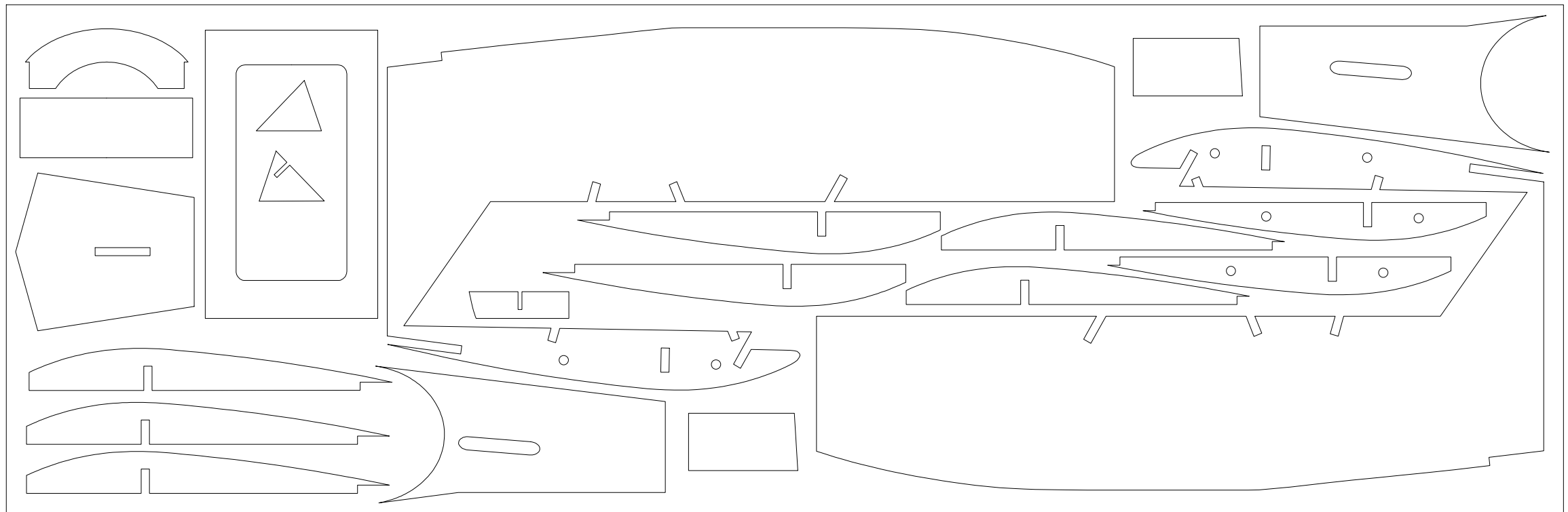

1/16 balsa