

THIS IS A TYPICAL MODIFICATION TO INCREASE COOLING AND IS NOT DRAWN TO SCALE FOR THIS PARTICULAR AIRCRAFT.

Heat Buffs (not included)

Aluminum buffa plate to fit Heat Buffs. Heat Buffs are mounted on the fuselage and thereby aid in cooling.

This Modification is optional and need only be incorporated if additional engineering is desired.

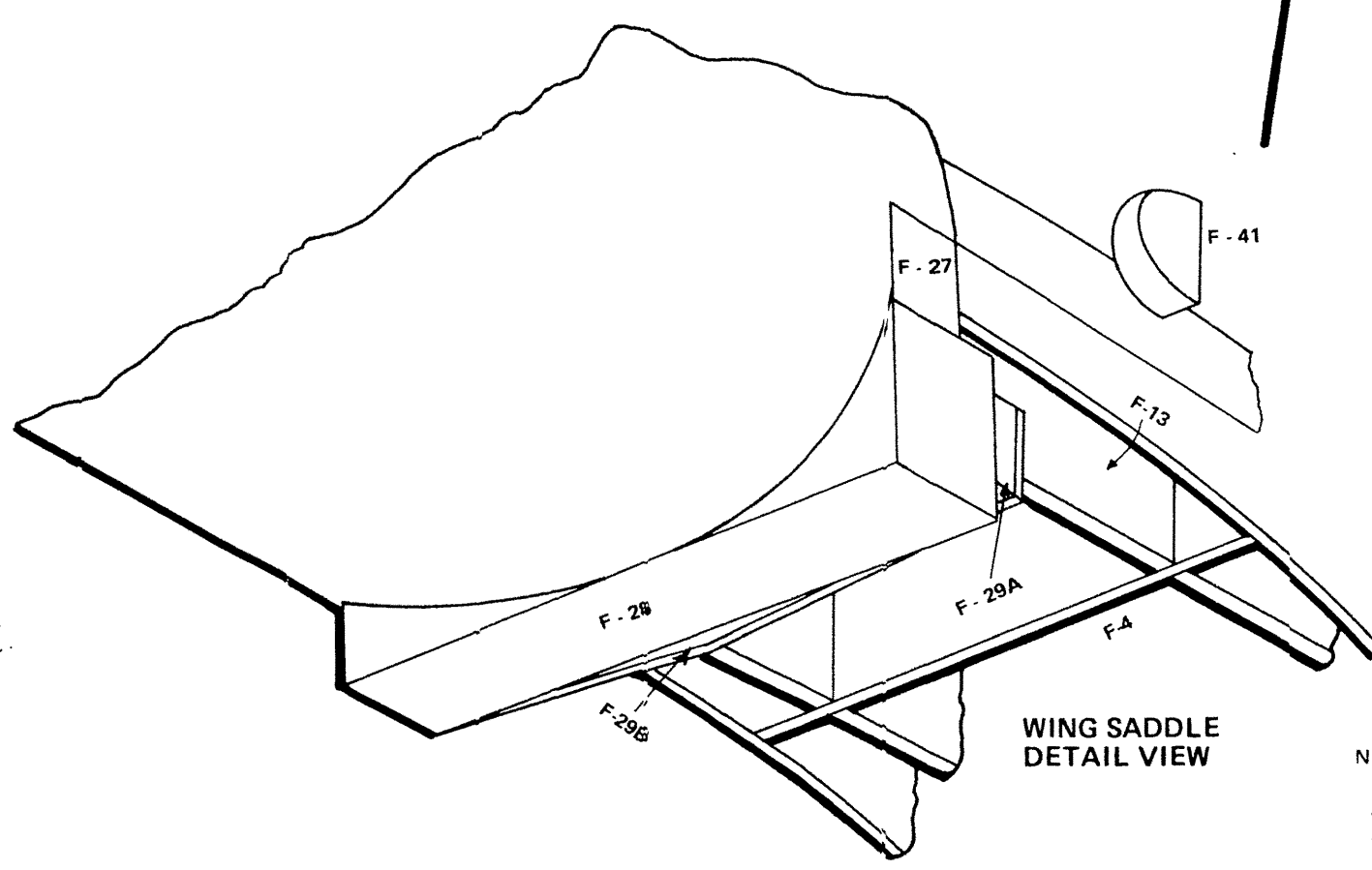
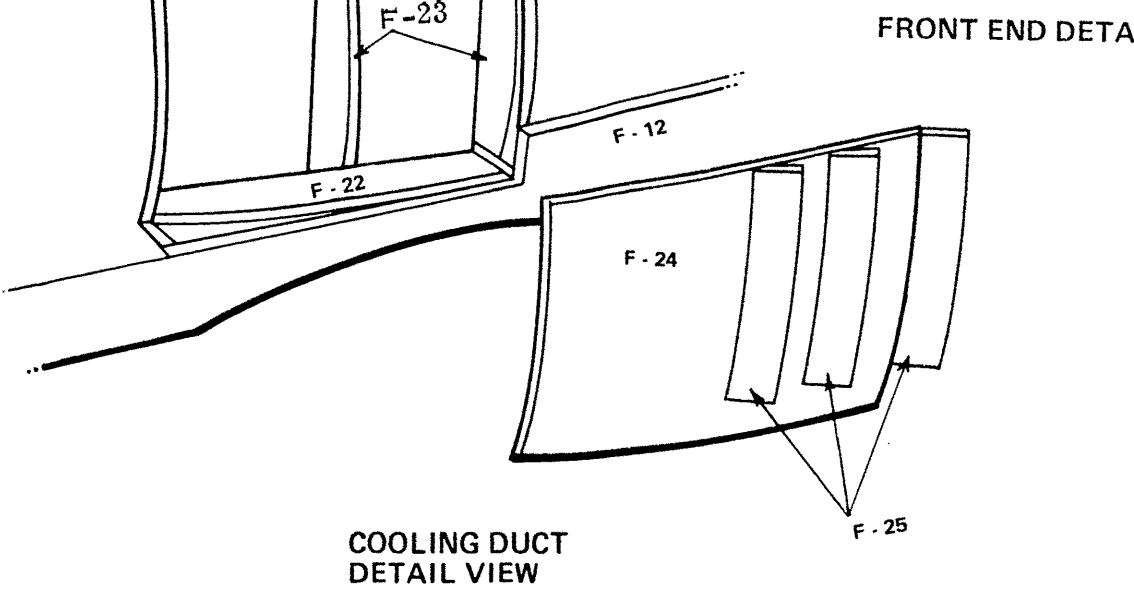

Note: To enhance flight characteristics of this model, scale air flow is being simulated and for the best air flow, the model may be attached to the fuselage.

FUSELAGE CONSTRUCTION

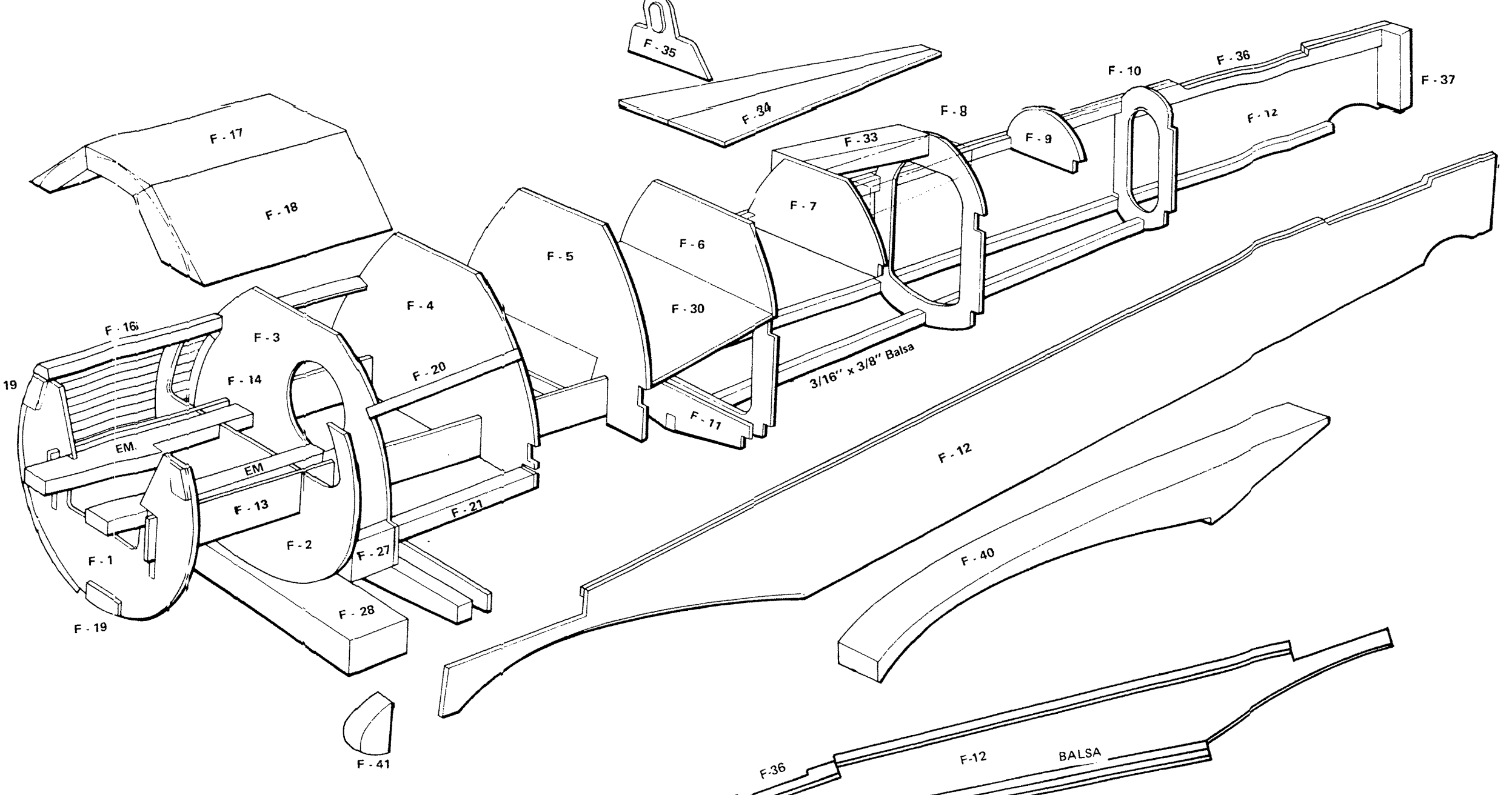

FIN & RUDDER CONSTRUCTION

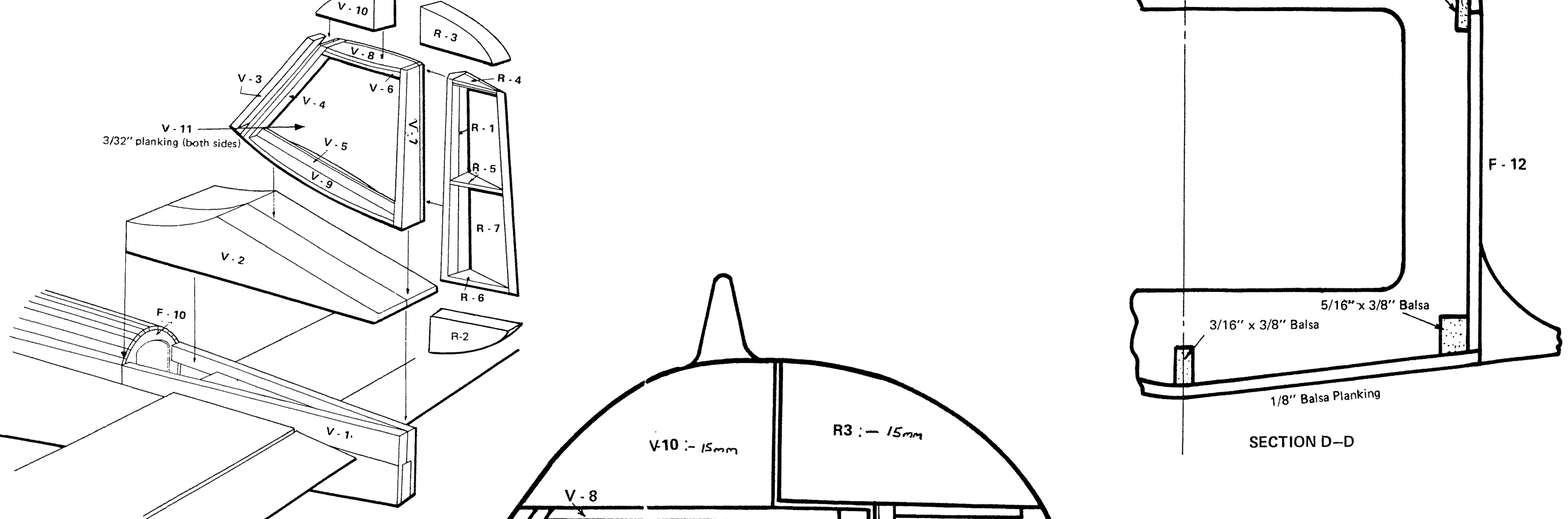

- RUDDER CONSTRUCTION
1. Glue parts V-3, V-4, F-5, V-6, and V-7 together as shown in detail view of rudder.
 2. When dry, add V-8 and V-9 to the V-11 sheet and the V-10 block in that order.
 3. Glue V-3 blocks together, do not attach to the fin at this time.
 4. Add on R-1, R-4, R-5, R-6 to one R-2.
 5. Add the other R-2, R-2, and R-3 in that order.
 6. Start glue the rudder assembly to the fuselage. Refer to the detail view for the correct glue application. The rudder should be attached to the fuselage in the correct position.
- NOTE: The V-3 block will be attached to the fuselage in the correct position and the horizontal ribs in the detail view.

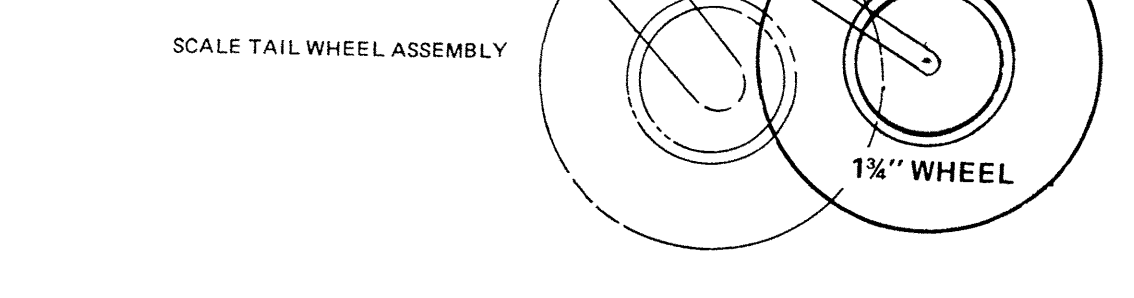

FOCKE-WULF
FW-190 A-8

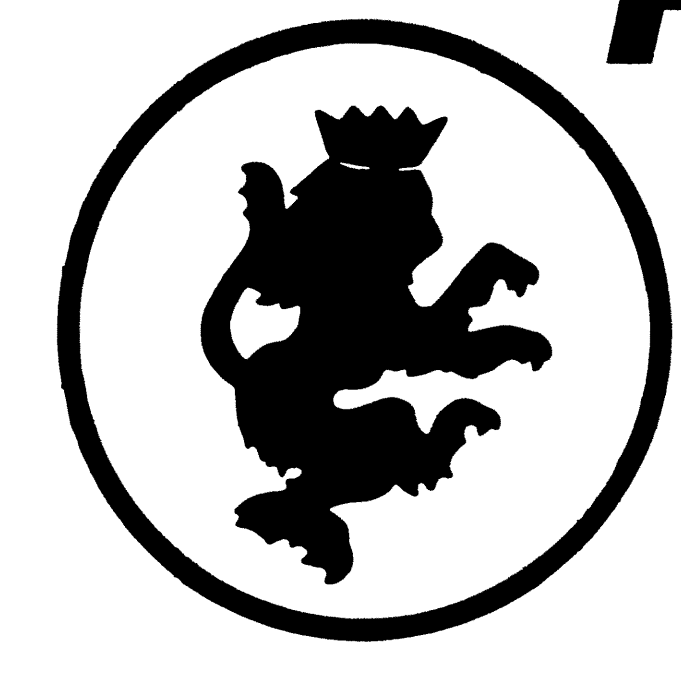

ROYAL PRODUCTS CORP.

ENGINE SIZE: 60 - 80
WING SPAN: 50 1/2 IN.
FUSELAGE LENGTH: 51 1/2 IN.
WING AREA: 642 SQ. IN.
SCALE RATIO: 1/32" = 1"



WING CONSTRUCTION

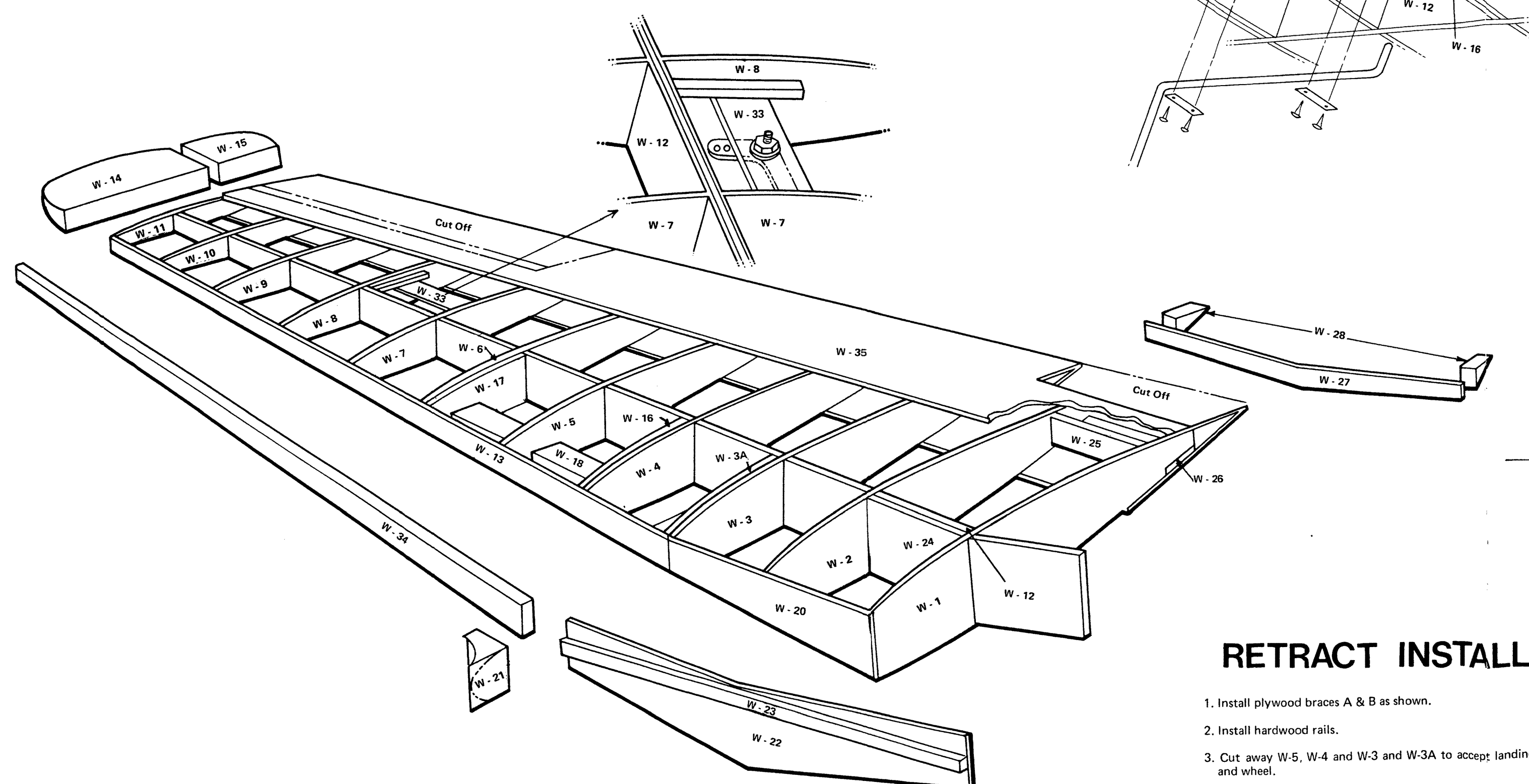

FIXED GEAR INSTALLATION

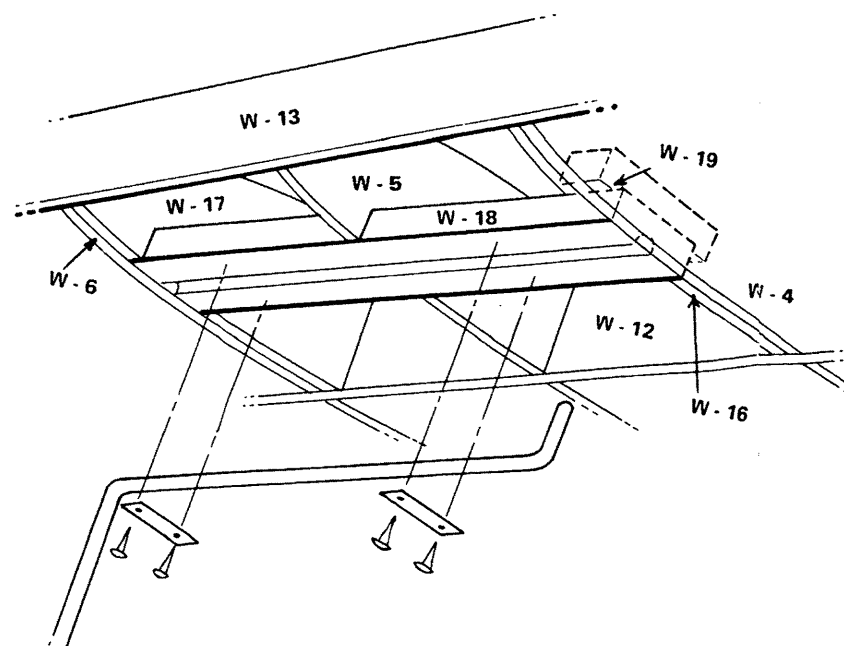

AILERON CONSTRUCTION

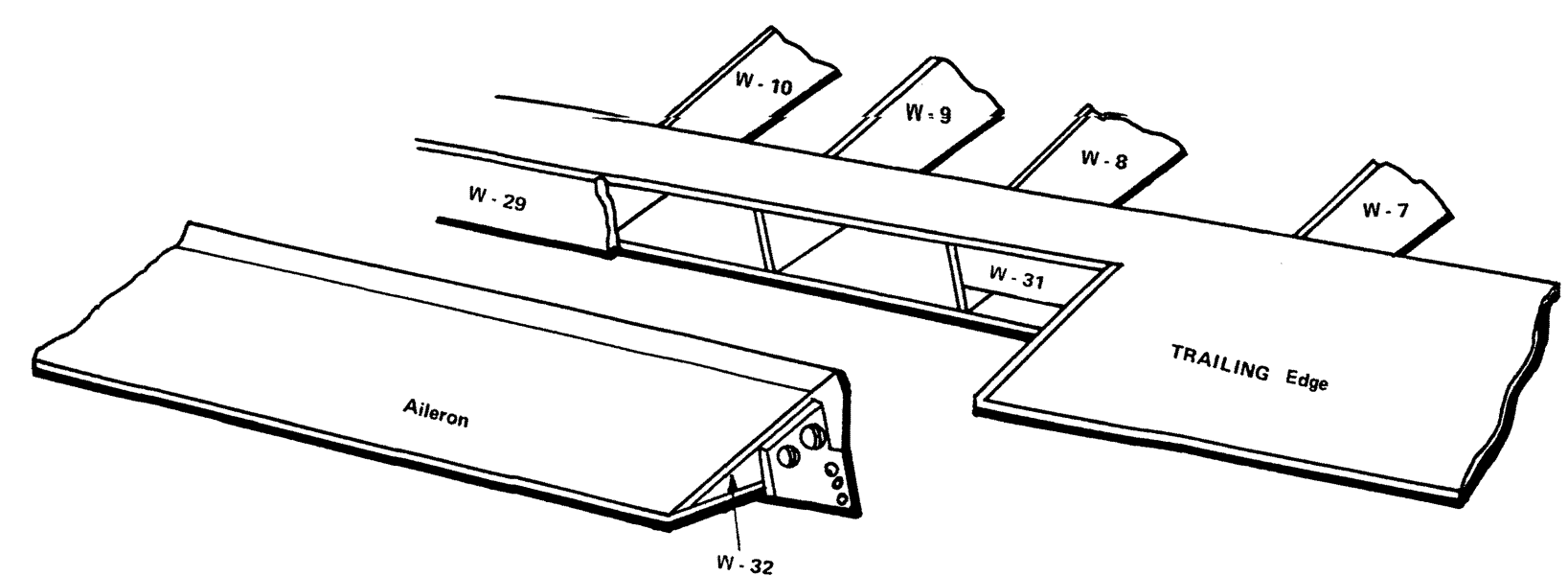

RETRACT INSTALLATION

1. Install plywood braces A & B as shown.
2. Install hardwood rails.
3. Cut away W-5, W-4 and W-3 to accept landing gear strut and wheel.
4. When retract mechanism is operating properly, adjust lower wing and cut away sheeting to accept wheel and strut cover.

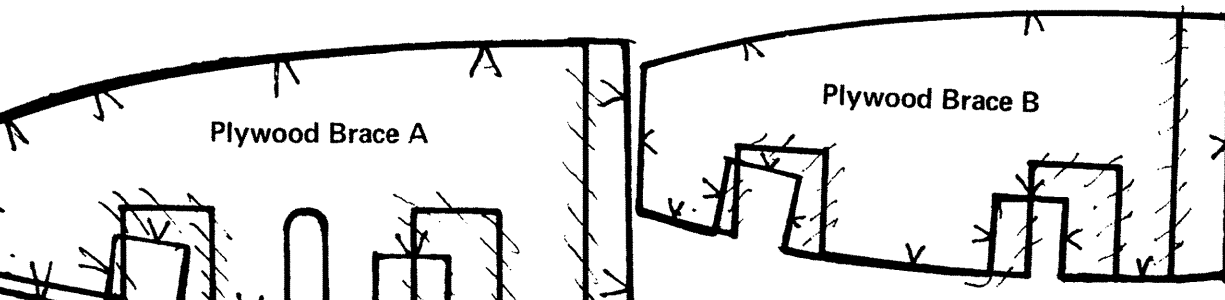
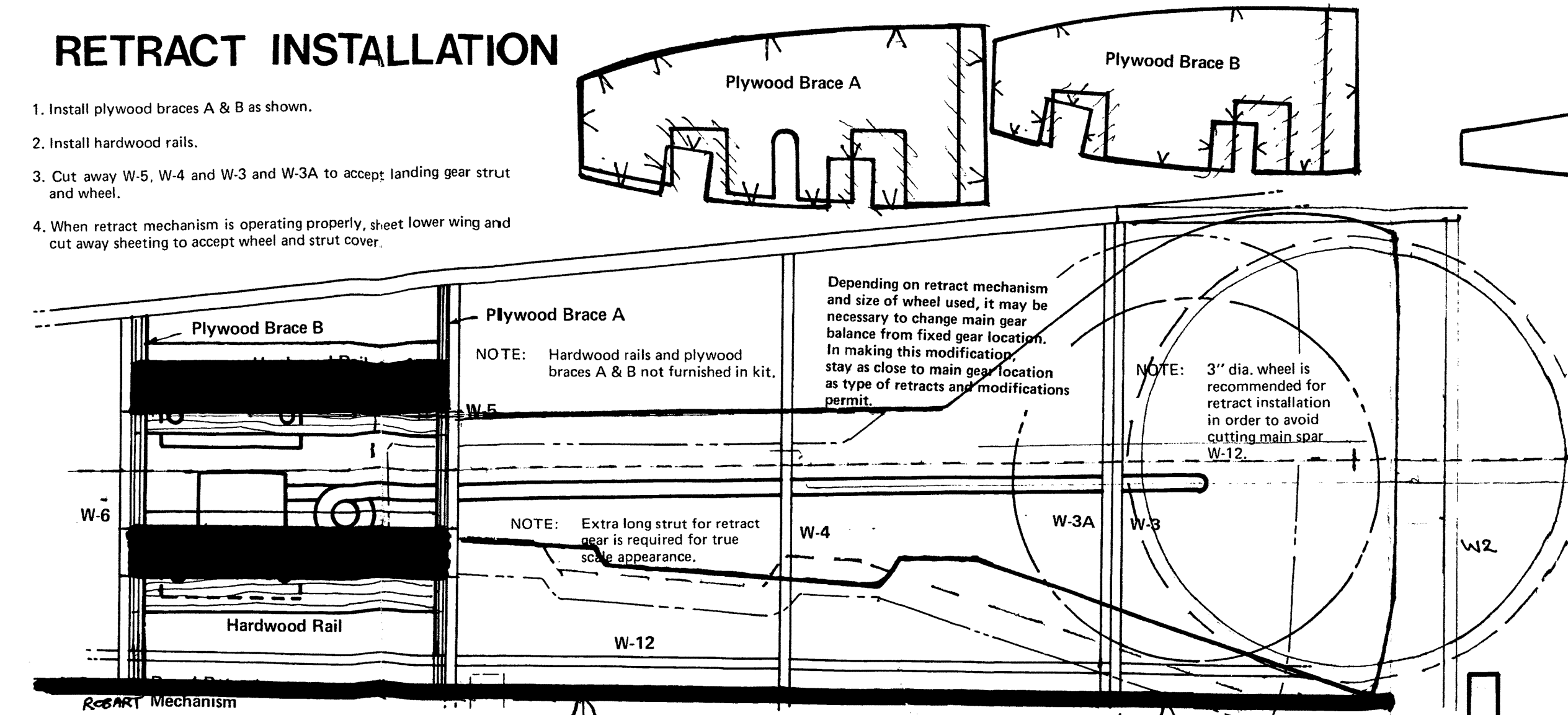

HORIZONTAL STABILIZER CONSTRUCTION

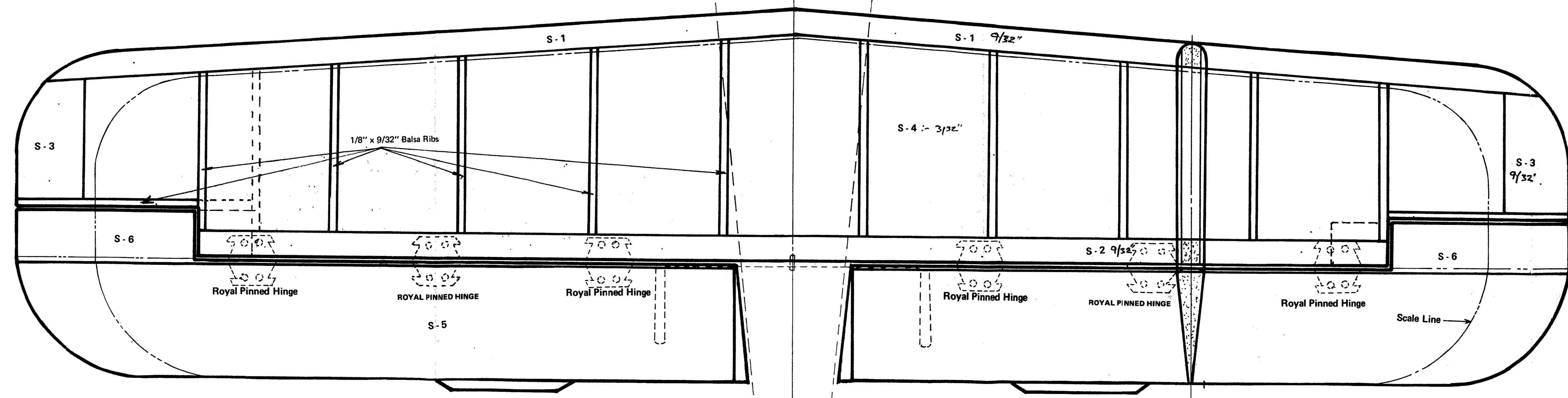

STABILIZER CONSTRUCTION

1. Glue the S-6s to the S-5s.
2. While glue is drying, glue the rib locations on one S-5 and glue S-7s, S-2s, and S-3s to glue on it.
3. Add ribs and the top sheet.
4. Spot glue elevator in place and when dry, sand to airfoil shape shown on stabilizer top view.

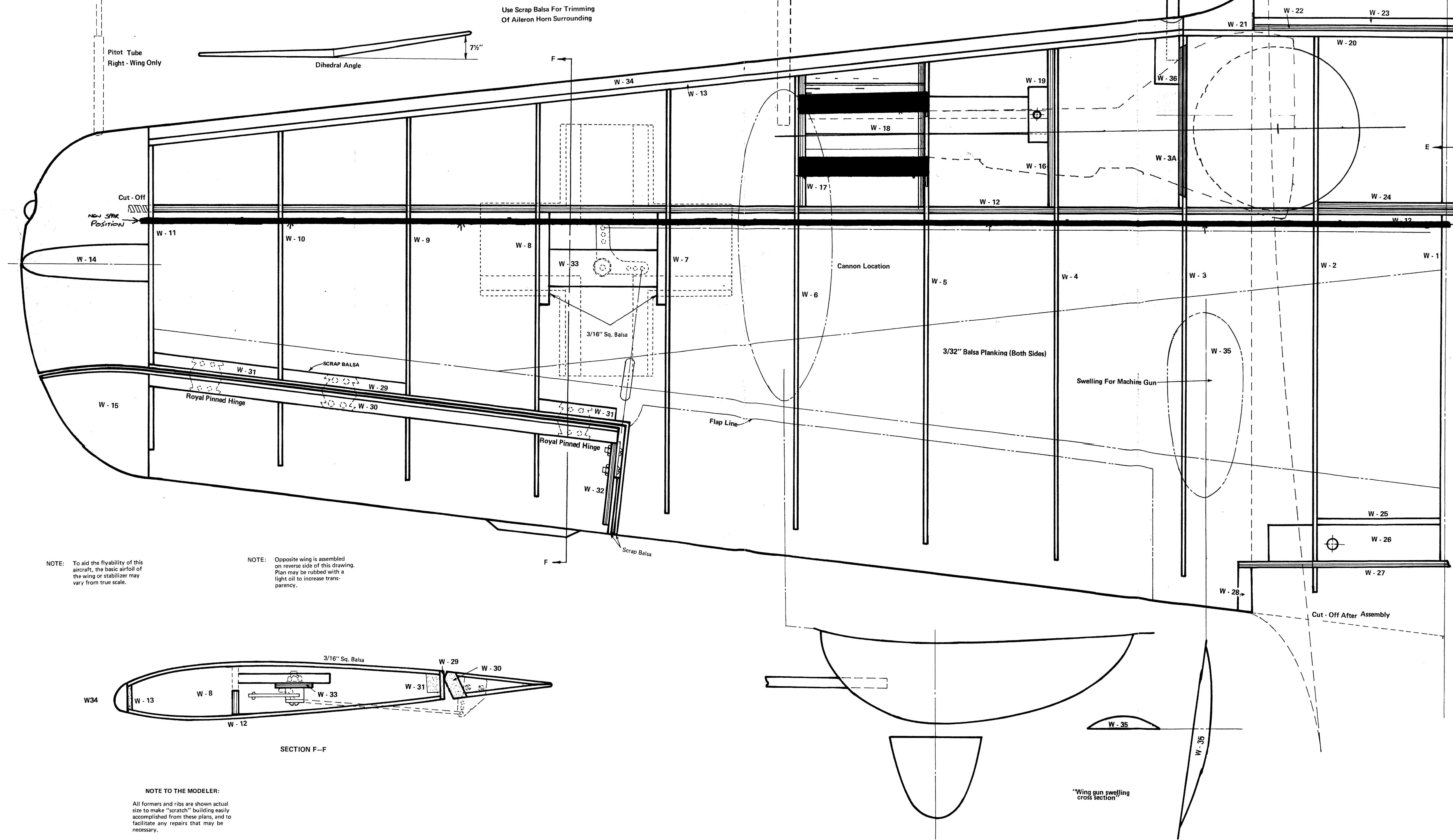
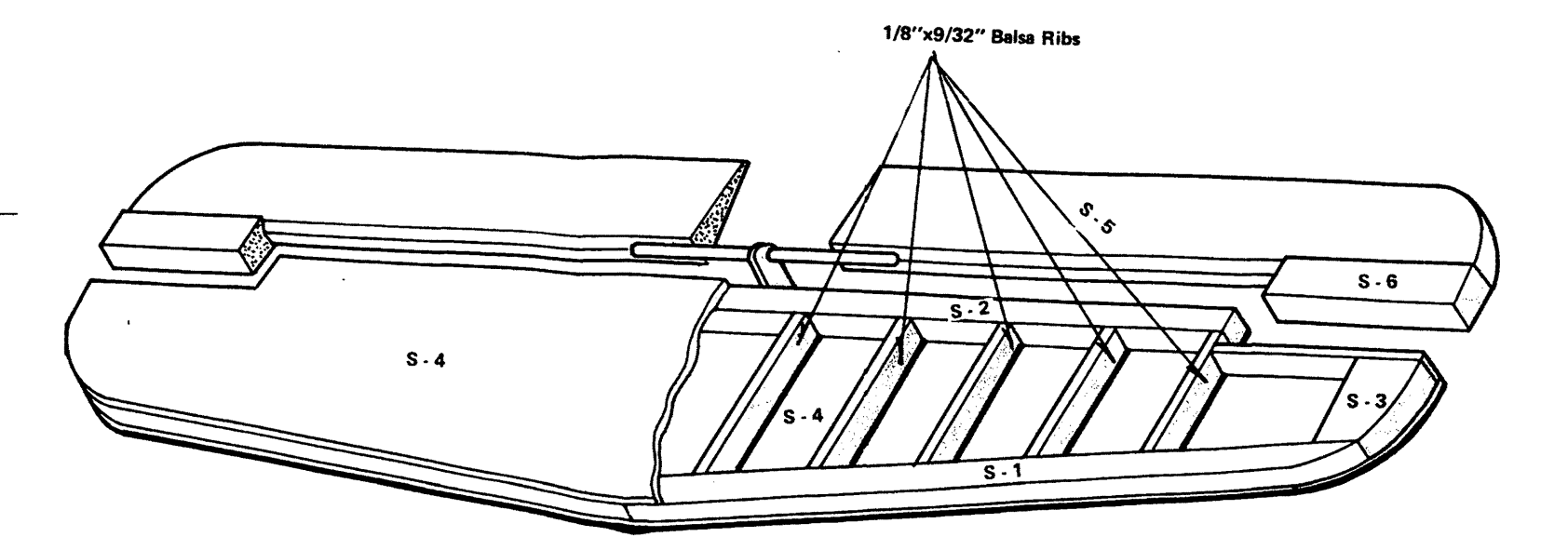

WING CONSTRUCTION

It is helpful to construct the wing first to allow proper fit in the fuselage. (If you are building a super scale version, this is the time to give some thought to such problems as flaps, lights, bomb releases, etc., which you must incorporate yourself. Keep in mind also that our recommended dihedral is 7 1/2\"/>

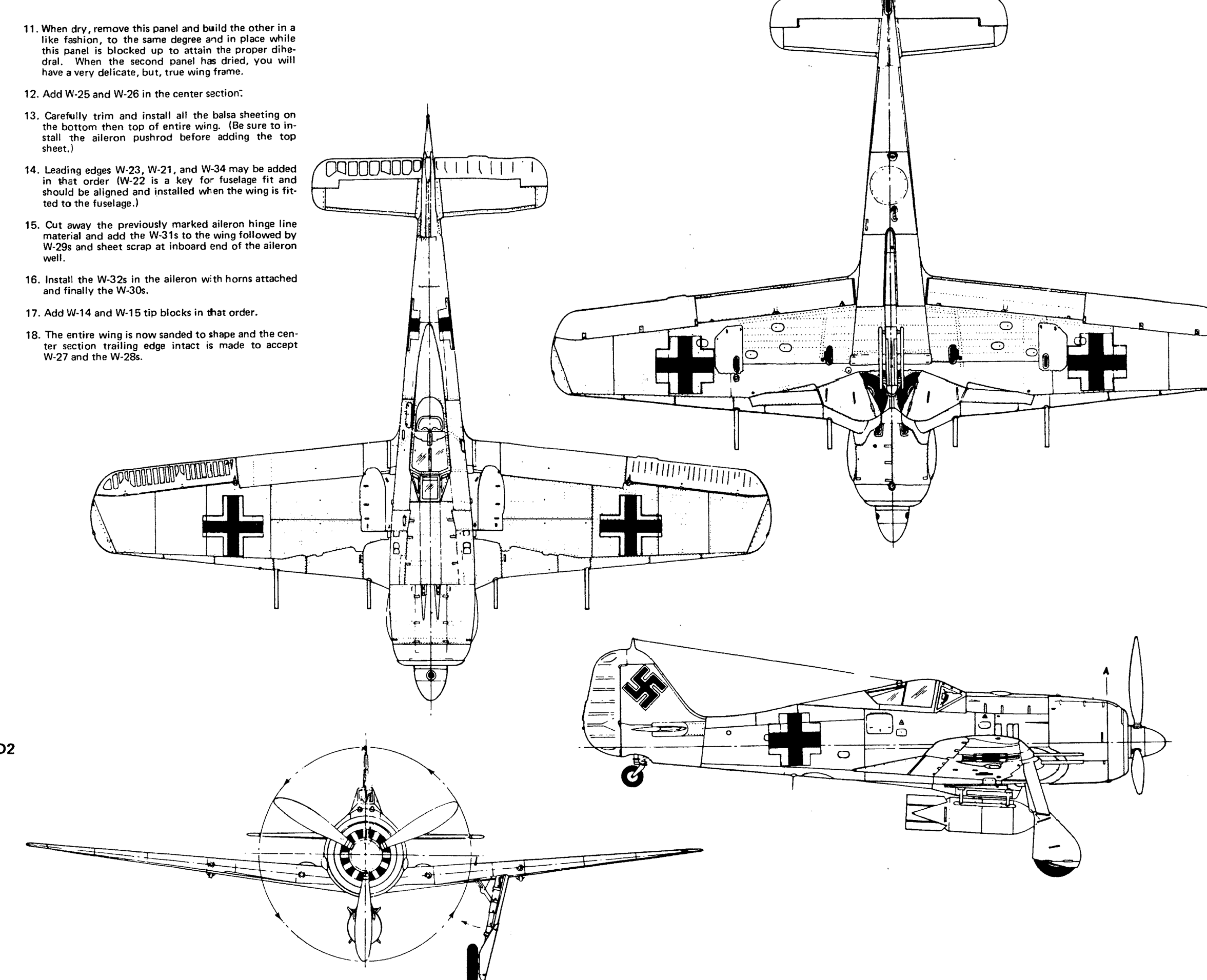

REAL PLANE SPECIFICATIONS:

WING SPAN 34' 5 1/2"
FUSELAGE LENGTH 29' 4 1/8"
LOADED WEIGHT 9,424 LB.
POWER 2100 HP BMW 801 D2
SPEED 405 MPH

FOCKE-WULF
FW-190 A-8



ROYAL
PRODUCTS CORP.

NOTE: To aid the flexibility of this aircraft, the basic airfoil of the wing or stabilizer may vary from true scale.

NOTE: Composite wing is assembled on reverse side of this drawing. Plan may be finished with a light oil to increase transparency.

NOTE TO THE MODELER:
All formers and ribs are shown actual size to make "test-run" building easily accomplished from these plans, and to facilitate any repairs that may be necessary.