

Eight Two Color Combinations with overall Vestal White (Standard on the Skylane)

| ACCENT COLOR | MAJOR COLOR |
|---------------|--------------|
| Single Maroon | Flag Red |
| Valvet Black | Flag Blue |
| Valvet Black | Star Gray |
| Pink Blue | Emerald Blue |
| Valvet Maroon | Flamingo |
| Valvet Black | Tiger Yellow |
| Tiger Yellow | Summer Gold |
| Green Green | Popper Green |

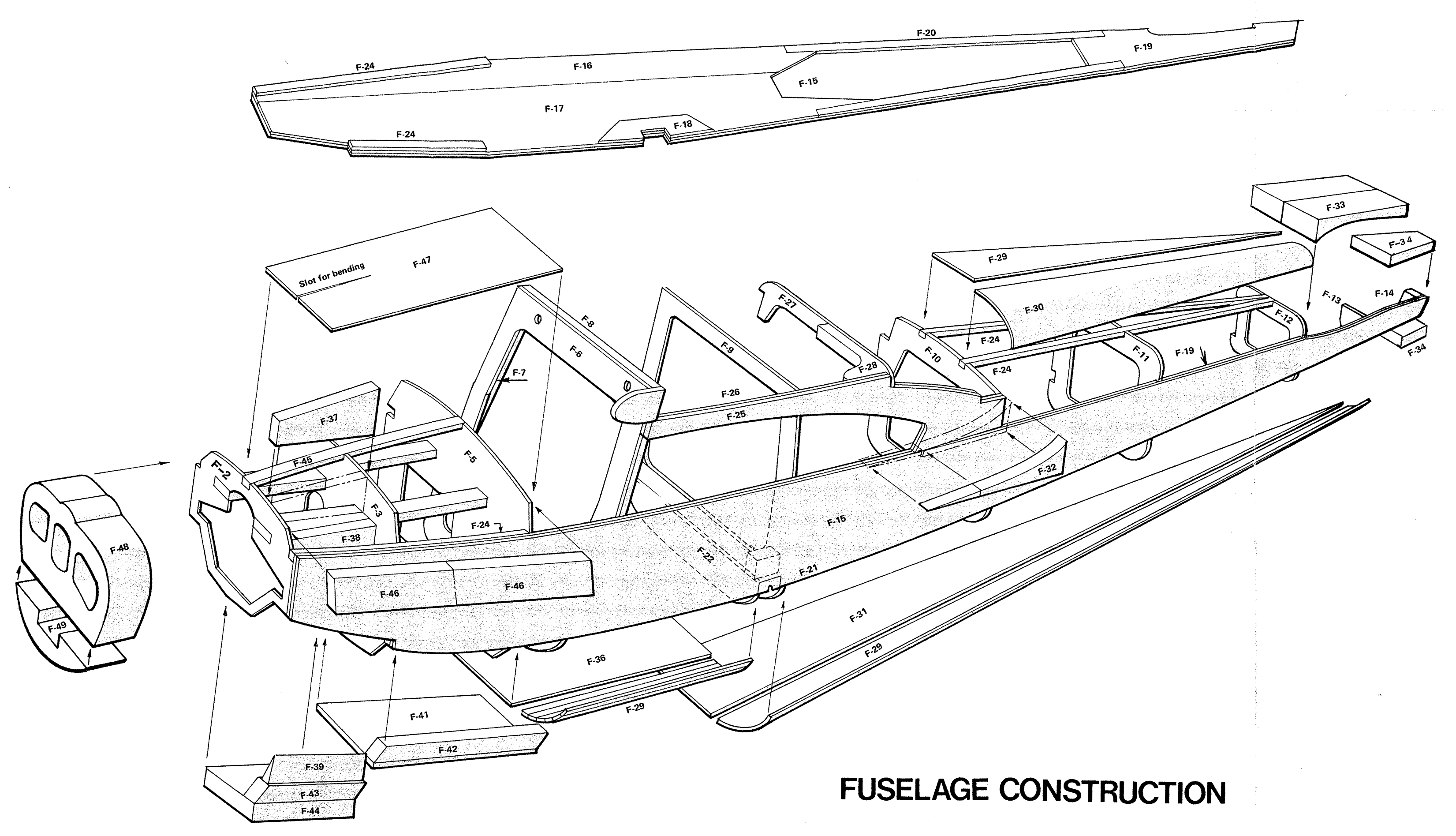

FUSELAGE CONSTRUCTION

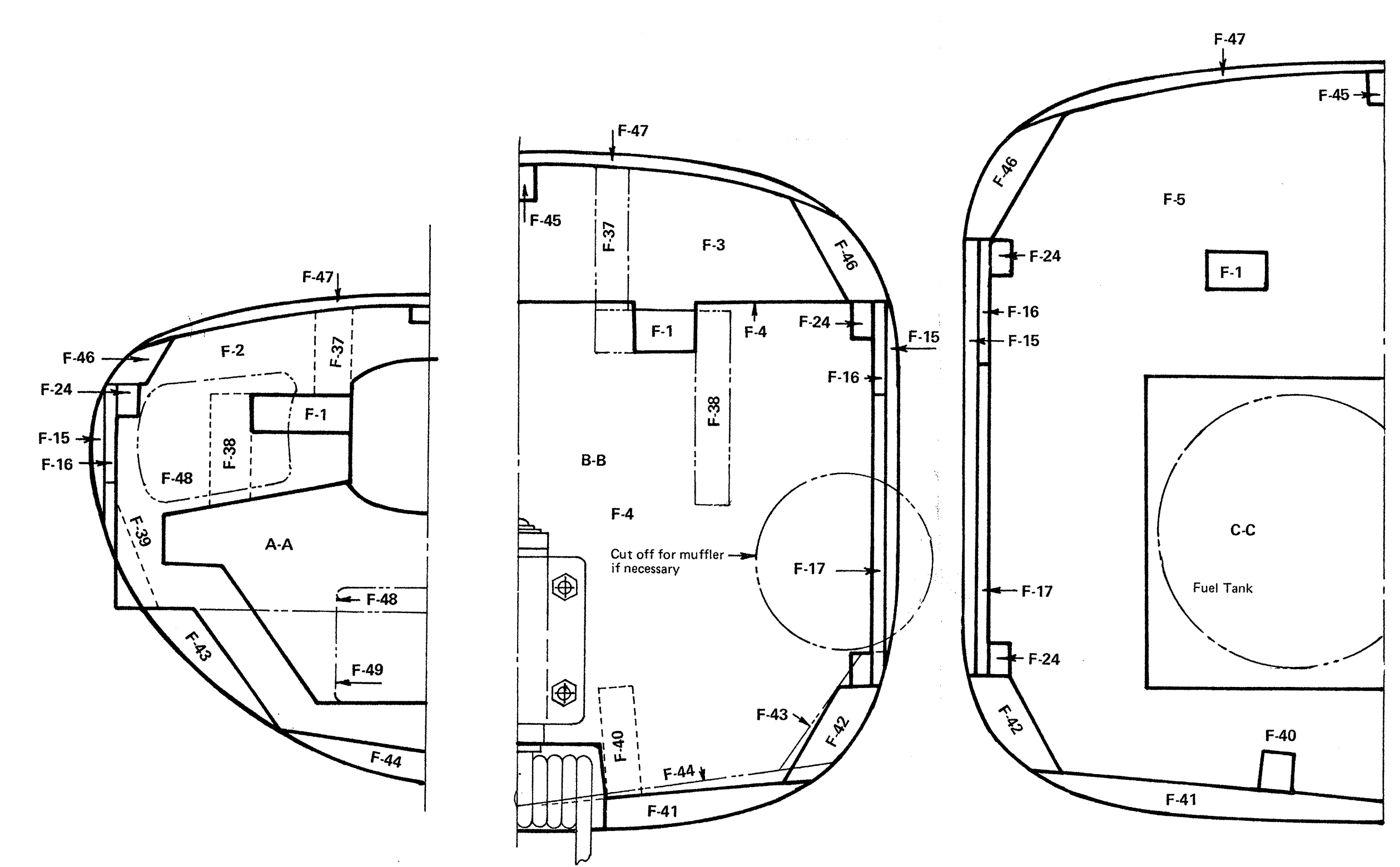
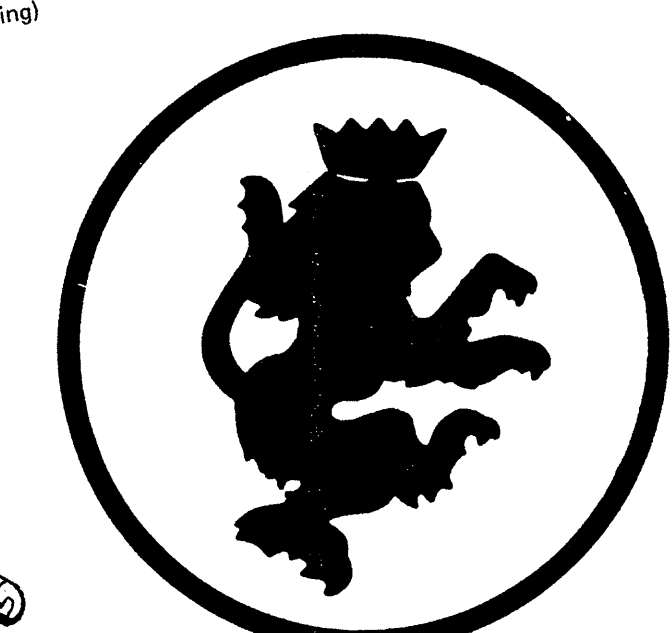

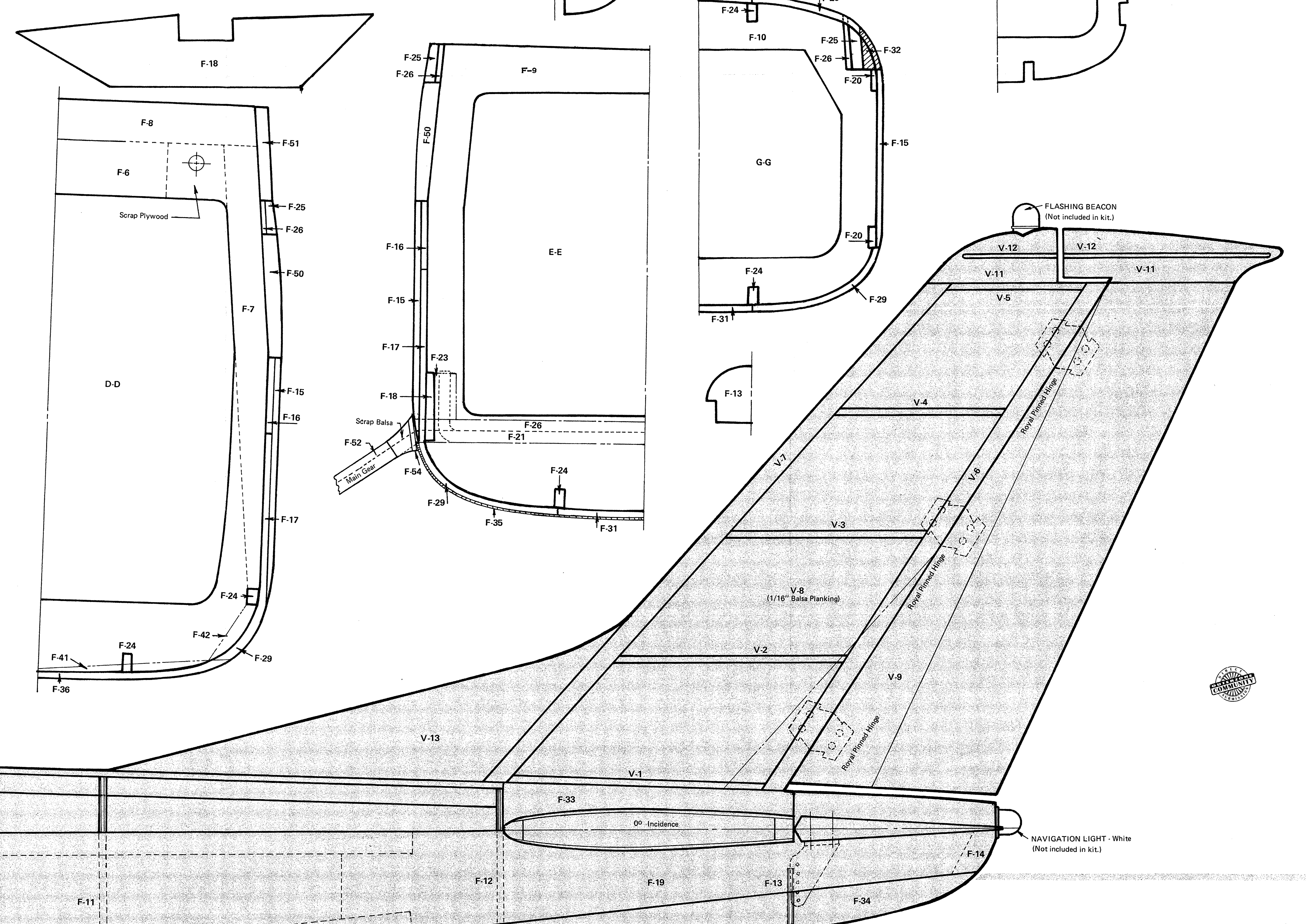

ROYAL PRODUCTS CORP.

CESSNA
182

SKYLANE

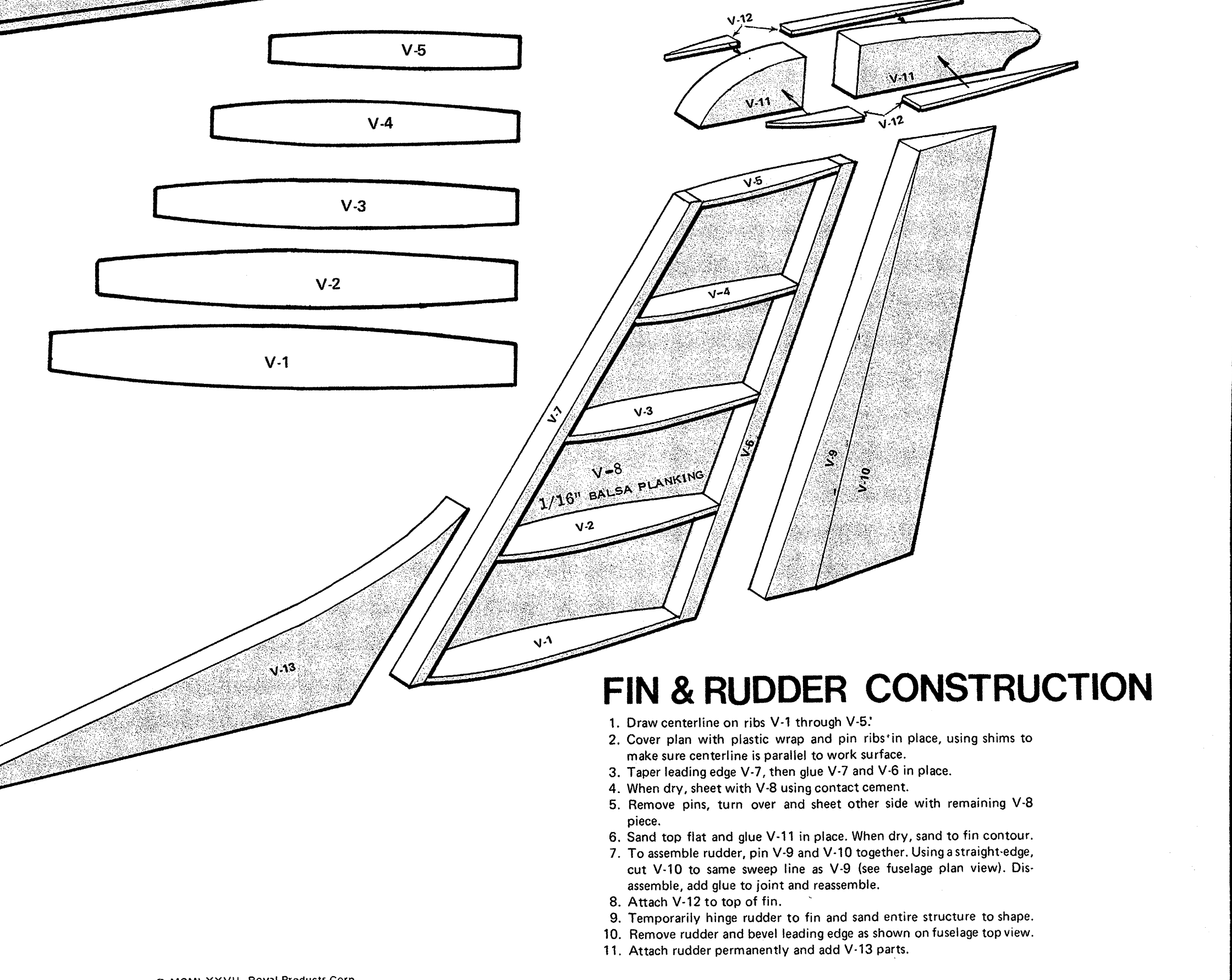

FIN & RUDDER CONSTRUCTION

1. Draw centerline on ribs V-1 through V-5.
2. Cover plan with plastic wrap and pin ribs in place, using shims to make sure centerline is parallel to work surface.
3. Tape leading edge V-7, then glue V-7 and V-6 in place.
4. When dry, sheet with V-8 using contact cement.
5. Remove pins, turn over and sheet other side with remaining V-8 piece.
6. Sand top flat and glue V-11 in place. When dry, sand to fin contour.
7. To assemble rudder, join V-8 and V-10 together, using straight edge cut V-10 to same sweep line as V-8 line. (See fuselage plan view). Die assemble, and glue to joint and reassemble.
8. Attach V-12 to top of fin.
9. Temporarily hinge rudder to fin and sand entire structure to shape.
10. Remove rudder and bevel leading edge as shown on fuselage top view.
11. Attach rudder permanently and add V-12 parts.

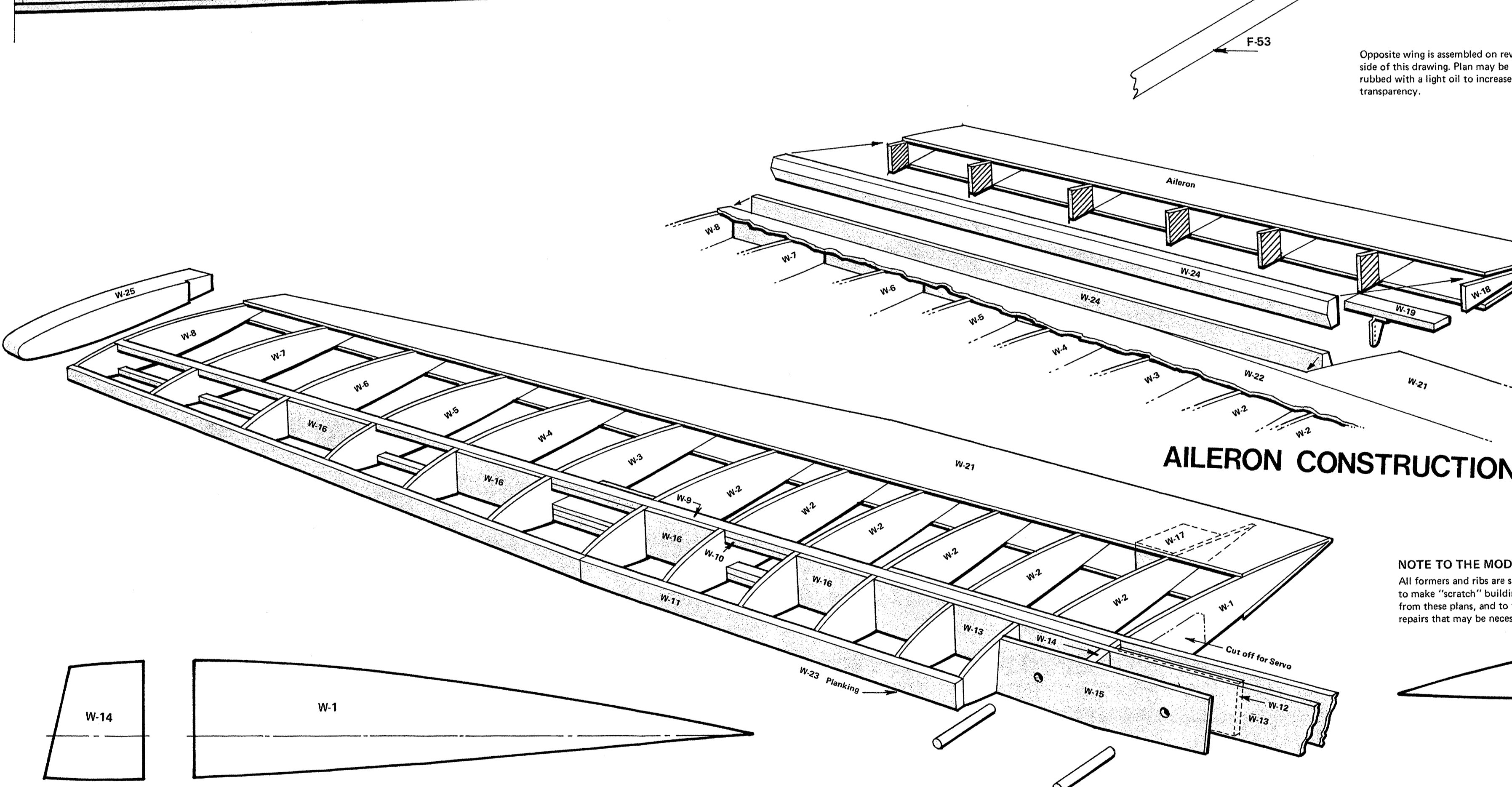
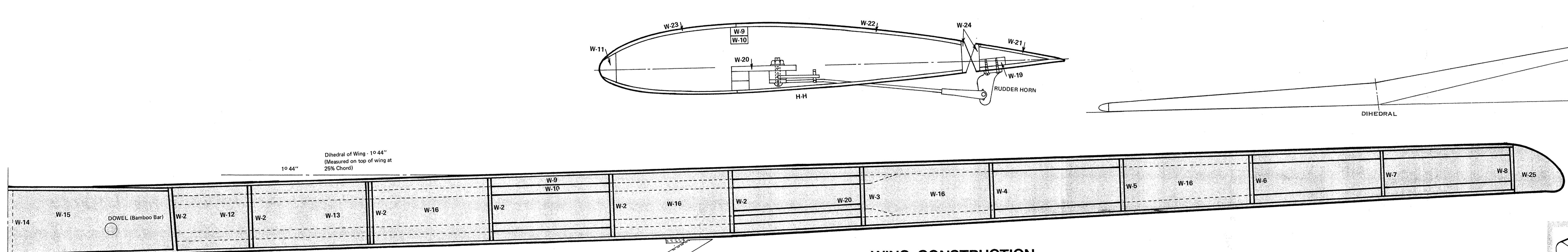
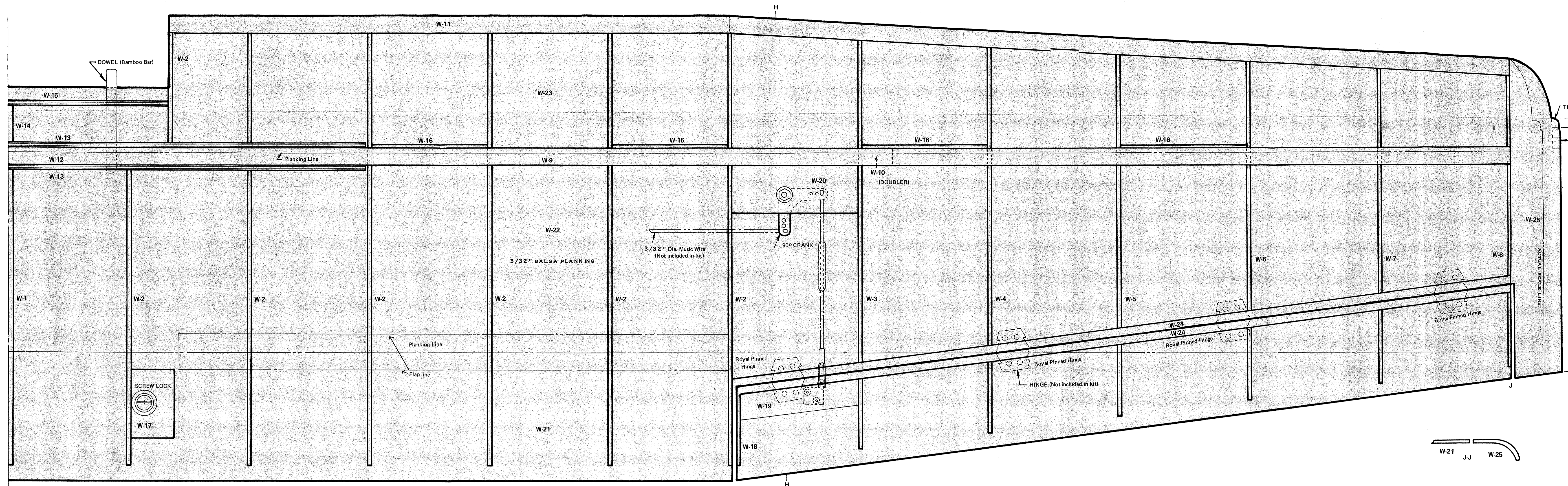

WING CONSTRUCTION

1. Separate the wing parts from the rest of the kit. Carefully study the plans and familiarize yourself with the location of the parts.
2. Draw centerlines on all the wing ribs. Also drill all pin holes in wing ribs.
3. Begin construction with the spar laminations. Pick two of the more flexible W-9 and W-10 spars and glue them together. These will be used for the lower spar. Take one W-9 and one W-10 and glue them together. Be sure the inboard ends match. Use a straight edge and be sure the spar and its doublers are straight. Repeat for other top spar.
4. To fabricate the lower spar, pin one of the flexible W-9 spars on edge over the wing edge view. Be sure to use plastic wash between the spar and wing. Note there is a hole in the spar outboard of the last W-2 rib. Be sure the spar follows the contour in this area. Pin and clamp a W-10 doubler to W-9. Use plenty of glue and be sure W-10 is tight against W-9. Align the inboard ends carefully. Make two assemblies, allow to dry completely.
5. When the spars are drying out the W-21 trailing edge sheeting. On two sheets, bevel the edge as shown in the wing end view. The edge must be beveled in order to have soft-faceted glue area when the top sheet is attached. Make one right and one left.
6. When the spars are dry bevel the outboard ends of W-10 shown on plans.
7. Pin one top spar assembly to the plan with W-10 being top. Glue all the ribs in place except W-1 and the inboard 2 W-2 ribs. Measure to the centerline drawn previously and be sure the ribs are parallel to the work surface. Work carefully and check and double check that there are no twists in the wing.
8. Add the bottom spar. If the bottom spar does not fit the rib notches (i.e. the bend in the spar is not correct) the best correction is to cut the spar apart at the last W-2 rib. Bevel the ends on a good right hand joint results. Cut a spar brace from the plywood sheet. Be sure that you do not cut a bulkhead or other piece. There is sufficient strength to make a couple of braces. Glue the brace along the front edge of the spar. You will have to relieve the W-2 spar notch. The brace should be a minimum of 4 inches long.
9. When the bottom spar is in place, glue the W-16 shear webs into the structure. Add the aileron bottom spar W-20 after drilling the pivot hole. Glue securely to W-2, W-3 and the bottom spar.
10. Cut the leading edge W-11 as indicated on the top wing view and bevel the ends for a tight joint. Note that the leading edge tapers outboard of the last W-2 rib. Sand or plane the taper into the leading edge before attaching. Be sure to preserve the original angle cut into W-11. Glue leading edge in place.
11. Bevel the underside of the ribs to support the trailing edge area. Cut one of the W-21 pieces that tap the beveled rib edge so that the sheet will not warp the bottom of the wing when it is attached. Bevel the joint for a tight fit. Glue the sheet in place on the bottom of the ribs. Be sure to use glue on joint line. Also be sure the inboard end of the sheet terminates at the wing centerline. Allow assembly to dry overnight.

12. Build the other panel repeating steps 7-11.
13. When both stations are complete, set the right skulion in place over the plans. Block up the outboard spar at several stations along the spar. Be sure the centerlines are parallel to the work surface.
14. Glue W-12 between the inboard part of the spars. Be sure to draw a centerline on W-12 and to be sure that only 1/2 of it is inserted between the spars. Glue and clamp the W-13 ply doublers in place again being certain that the dihedral angle is centered in the center joint.
15. Cut 4 7/8" ribs apart at the spar notch. Relieve them for the thickness of the ply shear edge view. Set 2 ribs aside for other panel. Glue the 2 ribs sections in doublers. Set 2 ribs and 2 tail ribs aside for other panel. Glue the 2 ribs sections in place. Before the glue sets add W-15 and W-14. Be sure W-15 is square to the wing structure and angled by the W-14 piece. Be sure the centerlines on W-2 (both sections) are parallel to work surface.
16. Glue the 2 W-2 tail sections in place to the spar and to the bottom sheeting. Glue W-1 in place being sure 1/2 of the width of W-1 extends past the wing centerline. Check the rib centerlines so as not to warp the wing.
17. Glue W-17 in place.
18. Install aileron push rod and allow inboard end to overhang centerline.
19. Unpin right panel. Flip plan over and pin left in place. Slide W-12 and W-13 doublers attached to right panel over spars on left panel. Block up the right wing tip 3". Check that the centerline of both panels is parallel to the work surface. When satisfied, glue the panels together. Add the W-2 nose and tail ribs to the left panel and also the other W-17 pieces. When dry, remove from work surface.
20. Install aileron push rod and bellcrank. Be certain they work freely and your installation is permanent.
21. Pin one side of wing to work surface (right or left) and sheet the top of the wing. Use W-21, W-22 and W-23. Make sure that you don't hide the pin locations so that the panel may be removed when dry.
22. Sheet other side of wing with W-21, W-22 and W-23.
23. When dry, sheet the bottom of the wing with the remaining W-22 and W-23 pieces.
24. After all sheeting is in place and dry, cut the aileron out area. Relieve the aileron for the W-24 cap pieces. Glue 1 W-24 piece on each wing out area. Glue W-18 and W-19 in each aileron inboard end. Add a W-24 cap to each aileron.
25. Glue wing to blocks W-25 in place. Relieve W-1 for servo.
26. Glue wing to blocks W-25 in place. Sand wing to radius shown on plans. Sand wing with progressively finer sandpaper.
27. Add leading edge doublers when fuselage is complete.

NOTE TO THE MODELER:
All forms and ribs are shown actual size to make "test-run" building easily accomplished from these plans, and to facilitate any repairs that may be necessary.

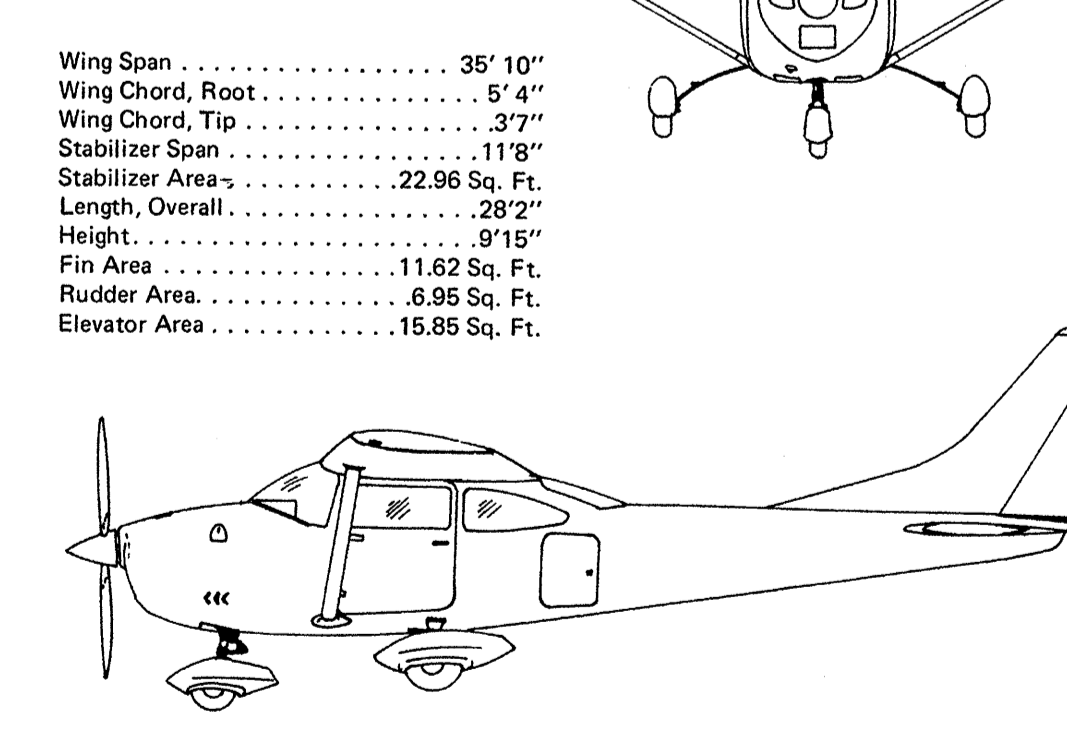
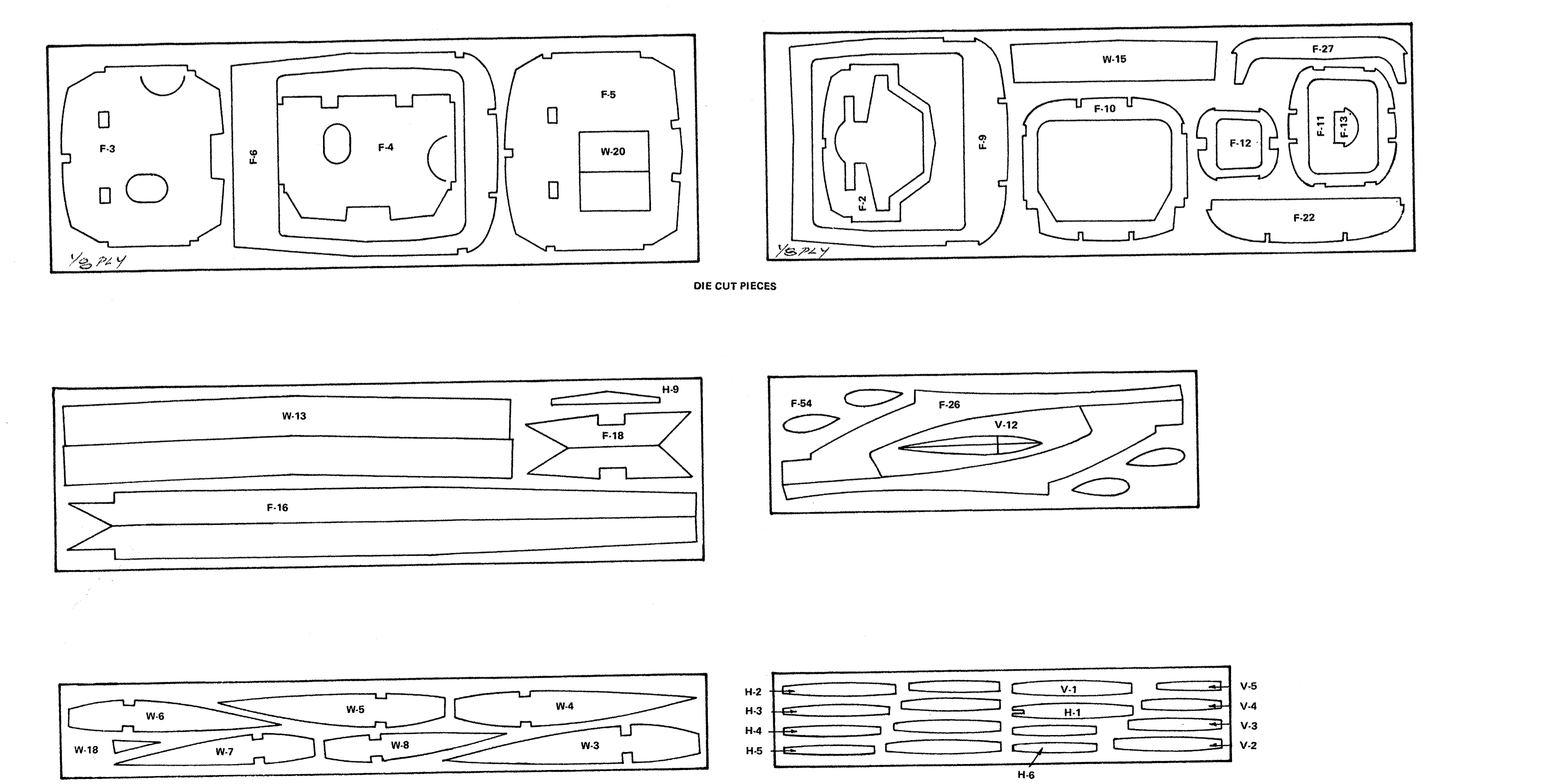
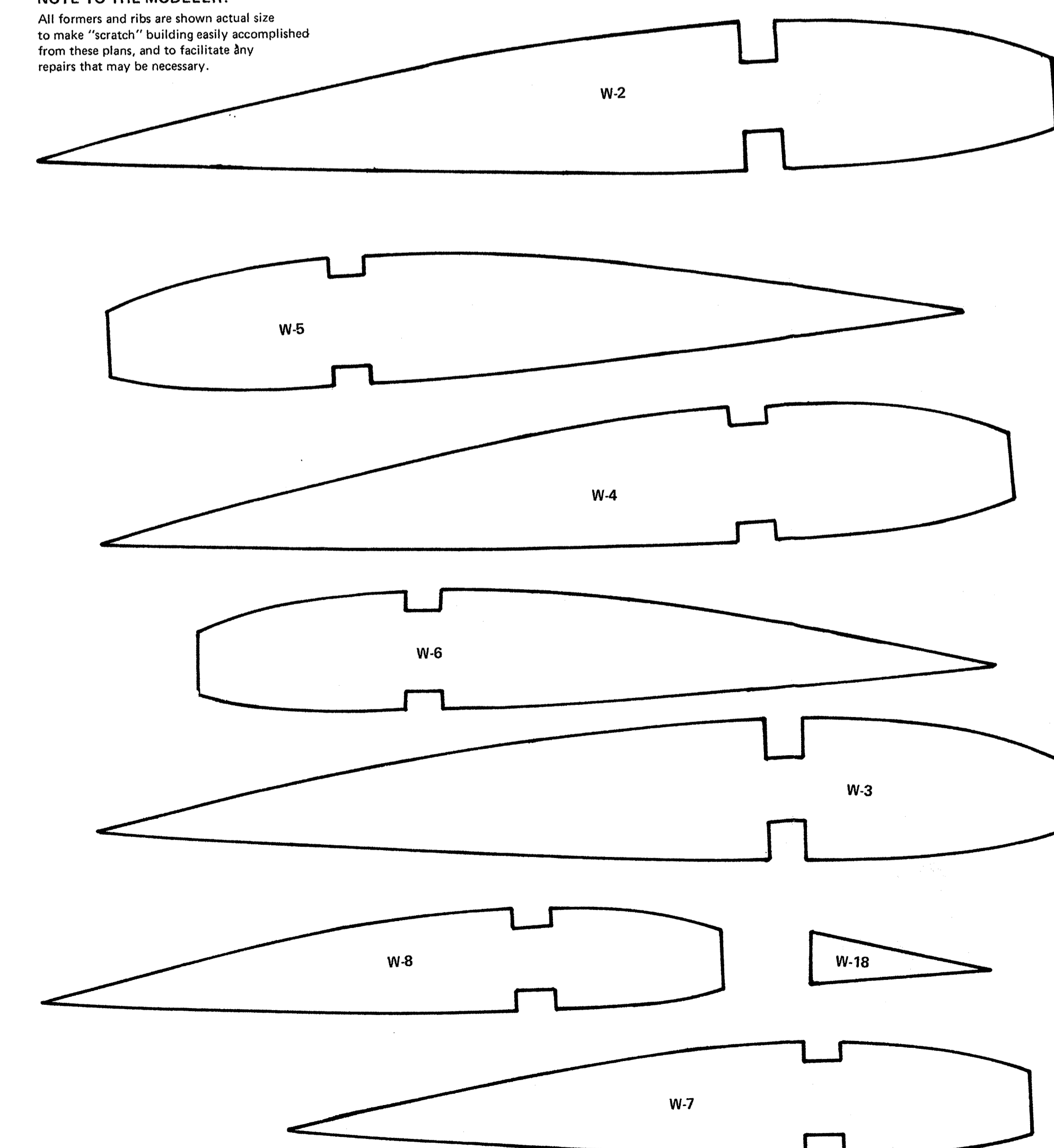

| | |
|------------------|---------------|
| Wing Span | 35' 10" |
| Wing Chord, Root | 5' 4" |
| Wing Chord, Tip | 2' 7" |
| Stabilizer Span | 11' 8" |
| Stabilizer Area | 22.86 Sq. Ft. |
| Length, Overall | 26' 2" |
| Height | 9' 10" |
| Fin Area | 11.62 Sq. Ft. |
| Rudder Area | 3.56 Sq. Ft. |
| Elevator Area | 15.89 Sq. Ft. |



CESSNA 182
SKYLANE

| | |
|-----------------|----------------|
| Engine Size | 45.61 |
| Wing Span | 71 2/3 in. |
| Fuselage Length | 55 7/16 in. |
| Wing Area | 700.45 sq. in. |
| Scale Ratio | 2" = 1' |

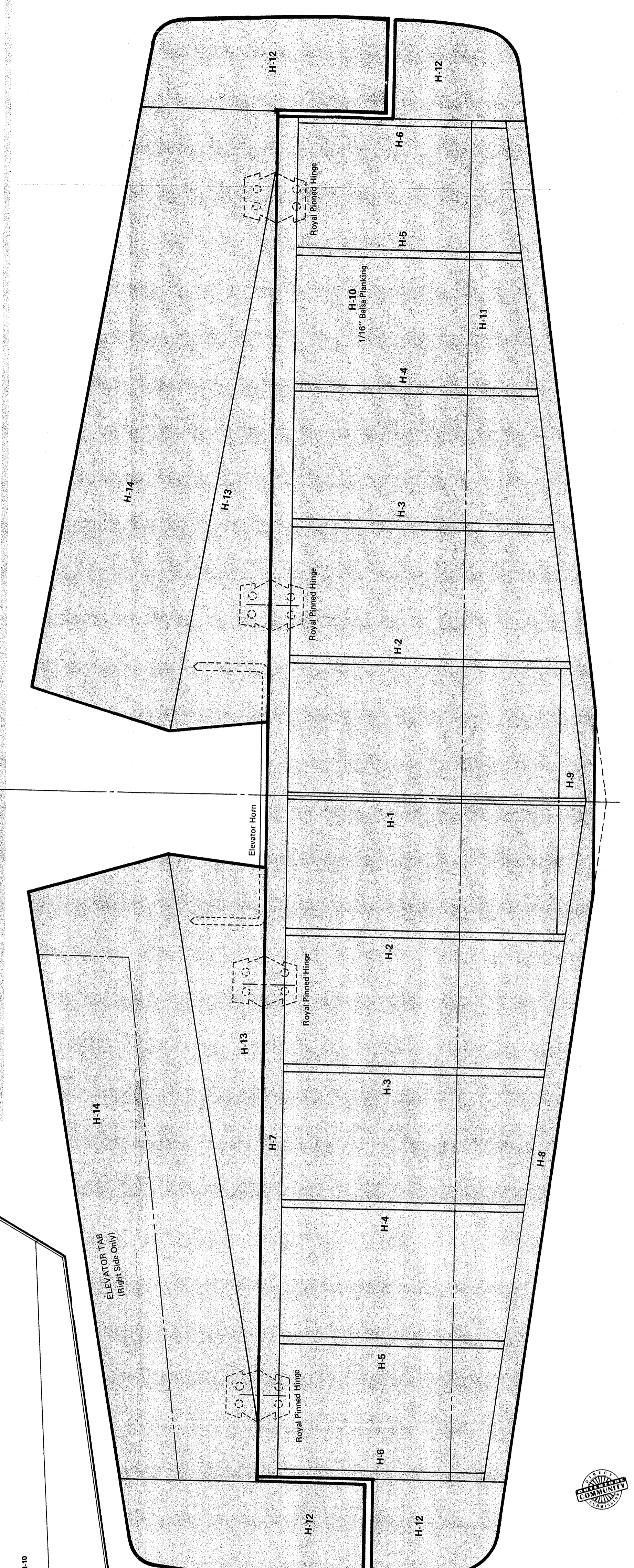

STABILIZER CONSTRUCTION

1. Mark positions on all stabilizer ribs H-1 through H-14. Use a sharp pencil.
2. Draw an outline of the stabilizer ribs on the ribs. Use a sharp pencil.
3. Show an outline of the stabilizer ribs on the ribs. Use a sharp pencil.
4. Show an outline of the stabilizer ribs on the ribs. Use a sharp pencil.
5. Show an outline of the stabilizer ribs on the ribs. Use a sharp pencil.
6. Show an outline of the stabilizer ribs on the ribs. Use a sharp pencil.
7. Show an outline of the stabilizer ribs on the ribs. Use a sharp pencil.
8. Show an outline of the stabilizer ribs on the ribs. Use a sharp pencil.
9. Show an outline of the stabilizer ribs on the ribs. Use a sharp pencil.
10. Show an outline of the stabilizer ribs on the ribs. Use a sharp pencil.
11. Show an outline of the stabilizer ribs on the ribs. Use a sharp pencil.
12. Show an outline of the stabilizer ribs on the ribs. Use a sharp pencil.
13. Show an outline of the stabilizer ribs on the ribs. Use a sharp pencil.
14. Show an outline of the stabilizer ribs on the ribs. Use a sharp pencil.
15. Show an outline of the stabilizer ribs on the ribs. Use a sharp pencil.
16. Show an outline of the stabilizer ribs on the ribs. Use a sharp pencil.