

NOTE:  
 For general construction the values of the dimensions given in this drawing are approximate. Specifications for materials and construction methods should be obtained from the manufacturer of the material used. The dimensions of the parts should be checked against the drawings of the parts before they are cut out.

SCALE PROP REFERENCE



**NOTE TO THE "SCRATCH" BUILDER**  
 Modified templates, scratch cutouts and other construction aids are available. Some are available in hard copy and some are available in digital format. See the website for more information.

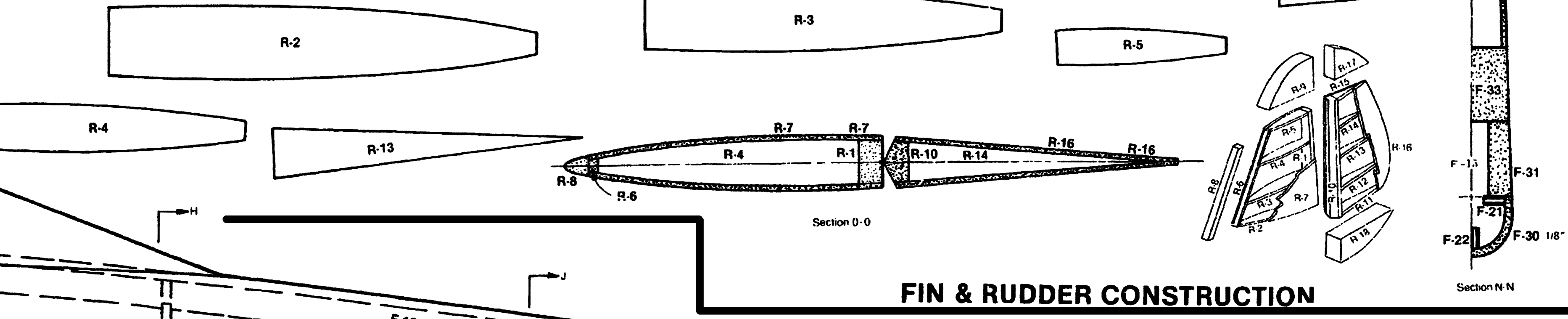
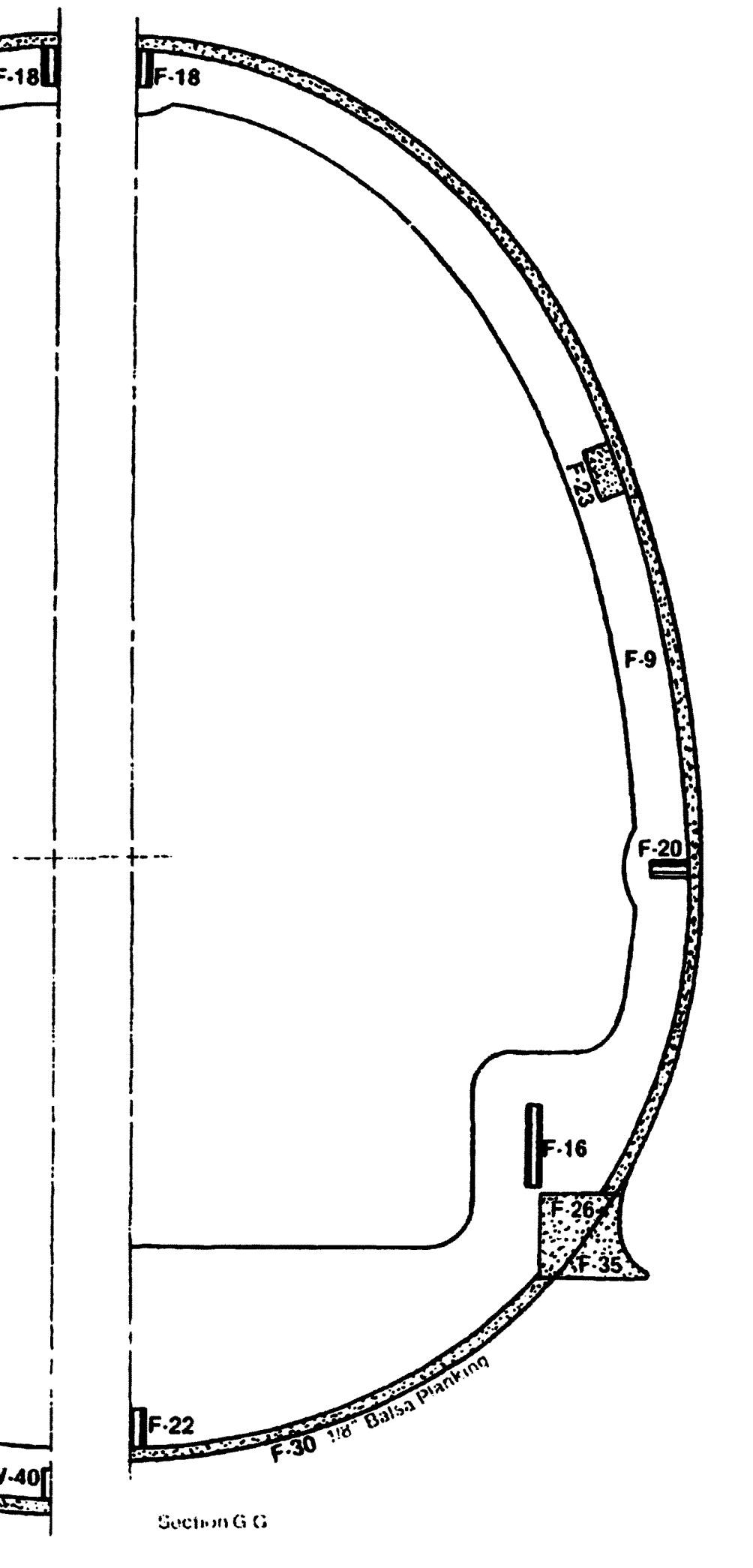
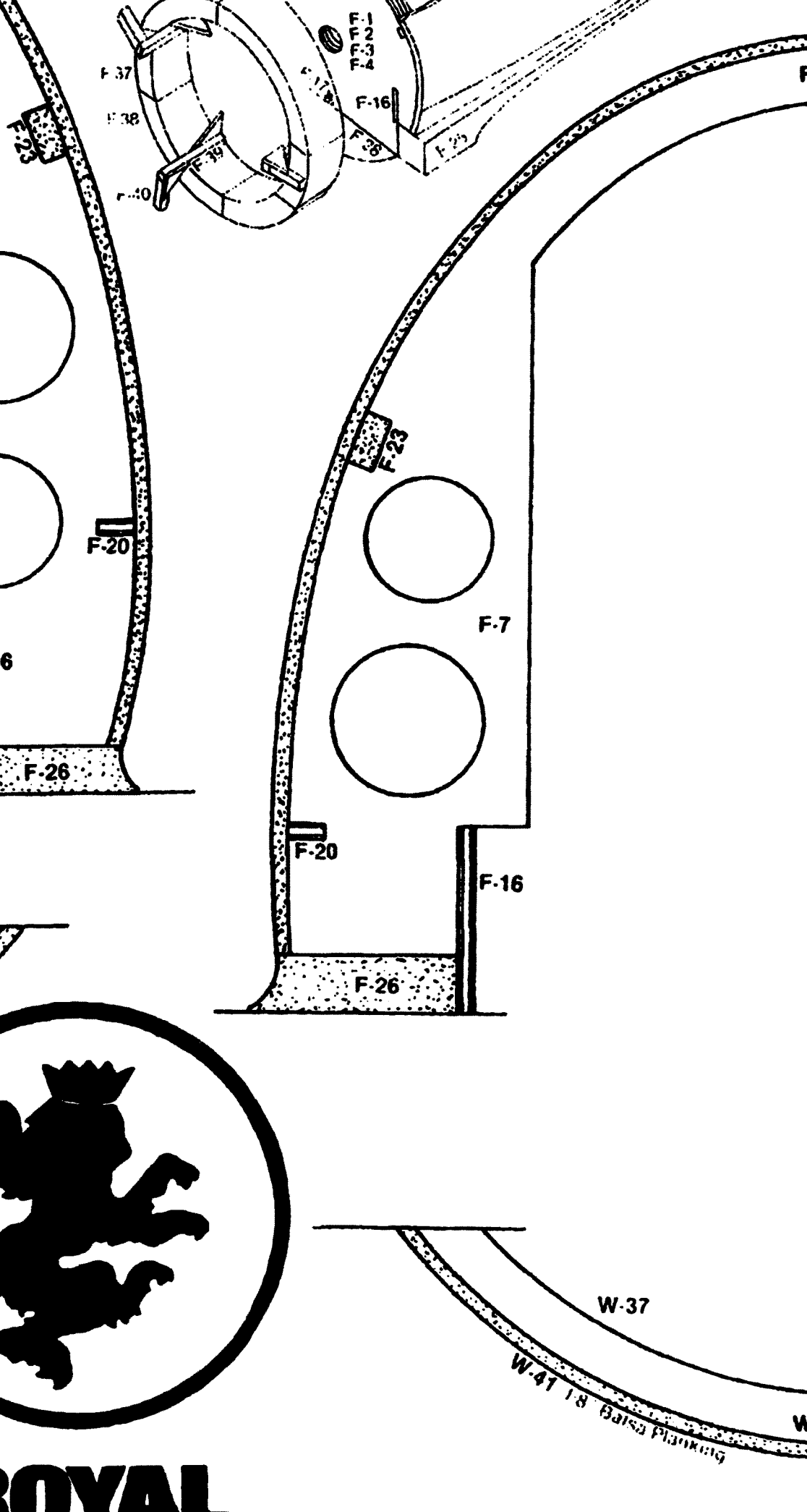
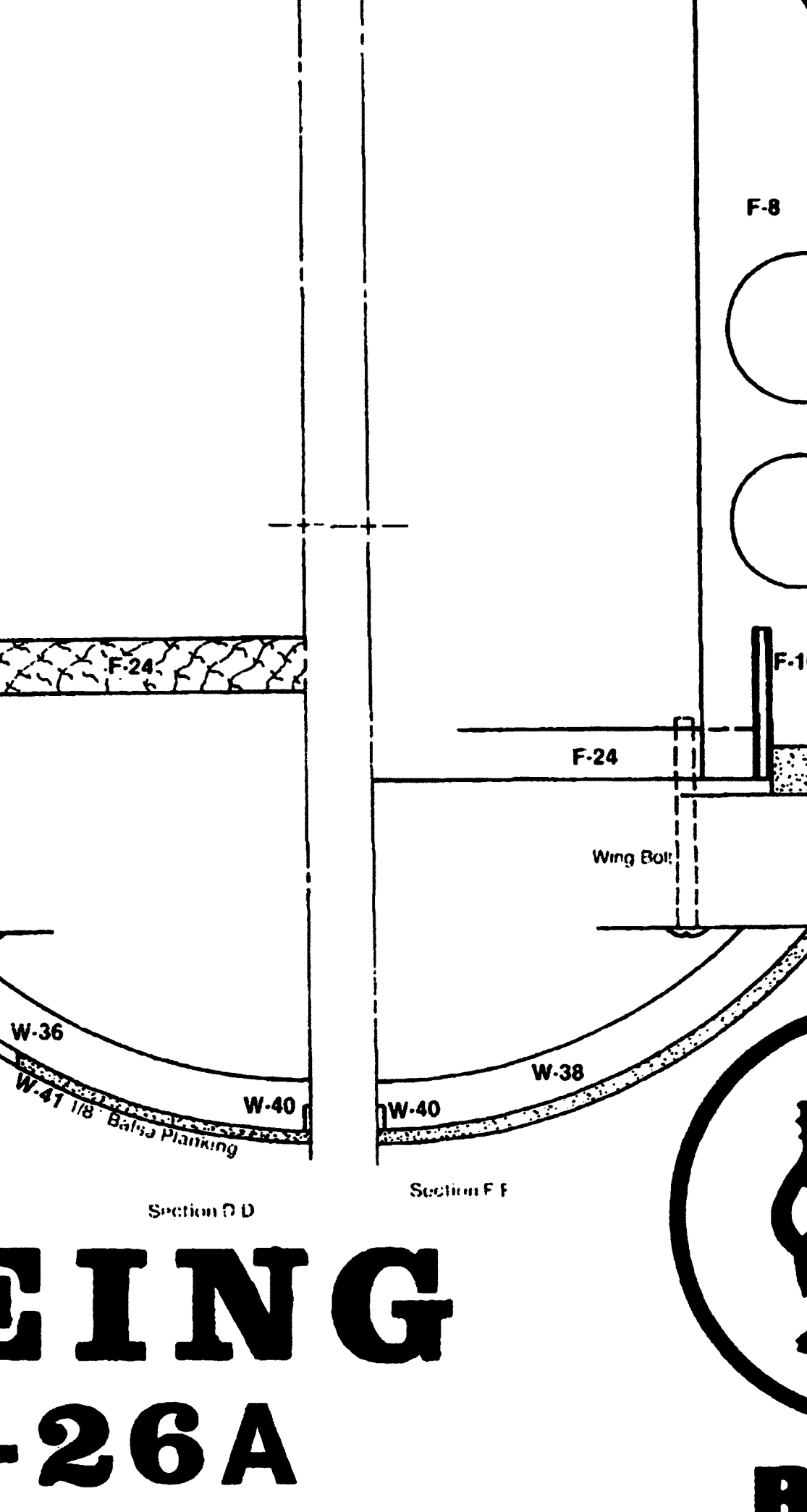
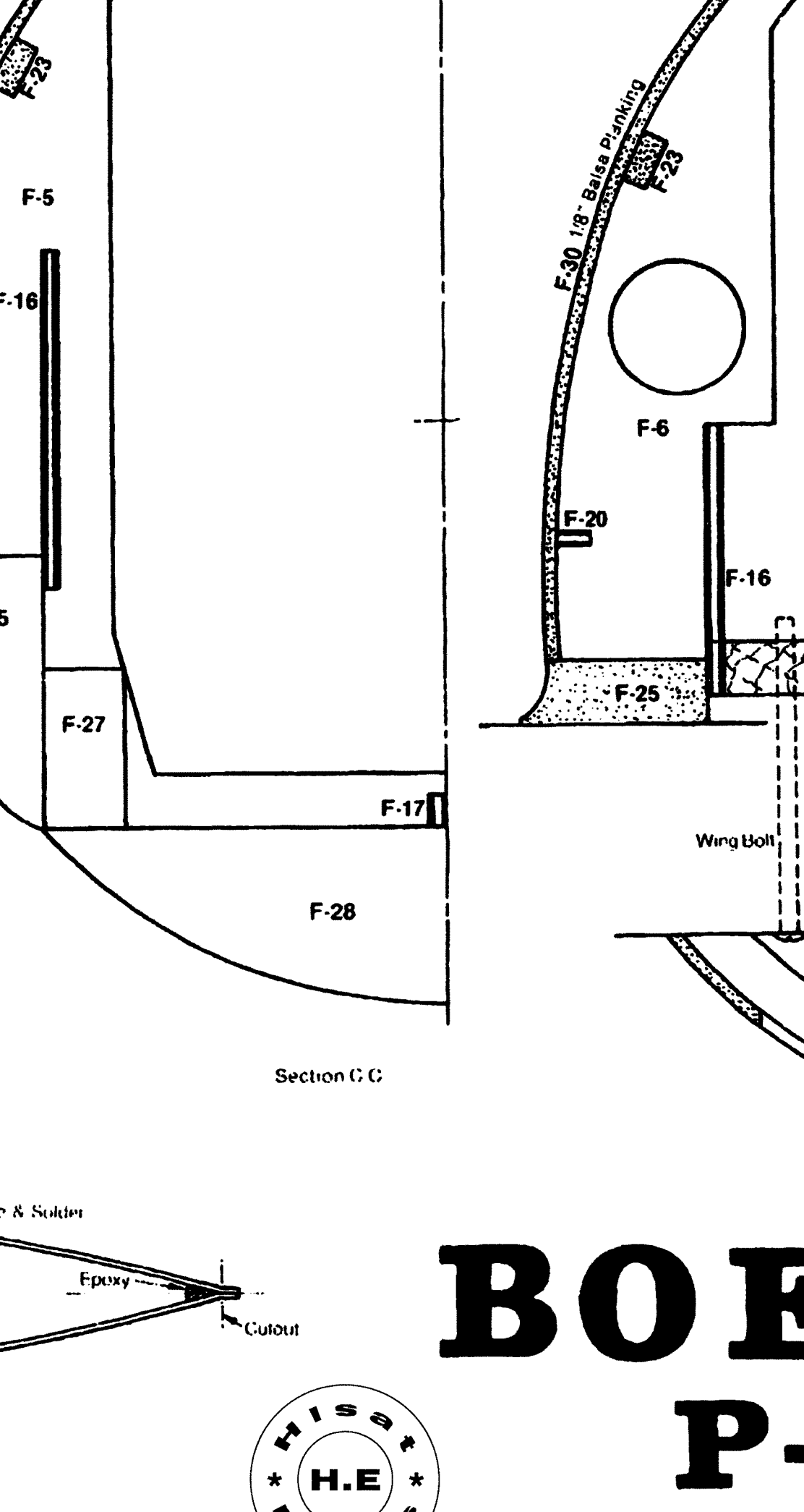
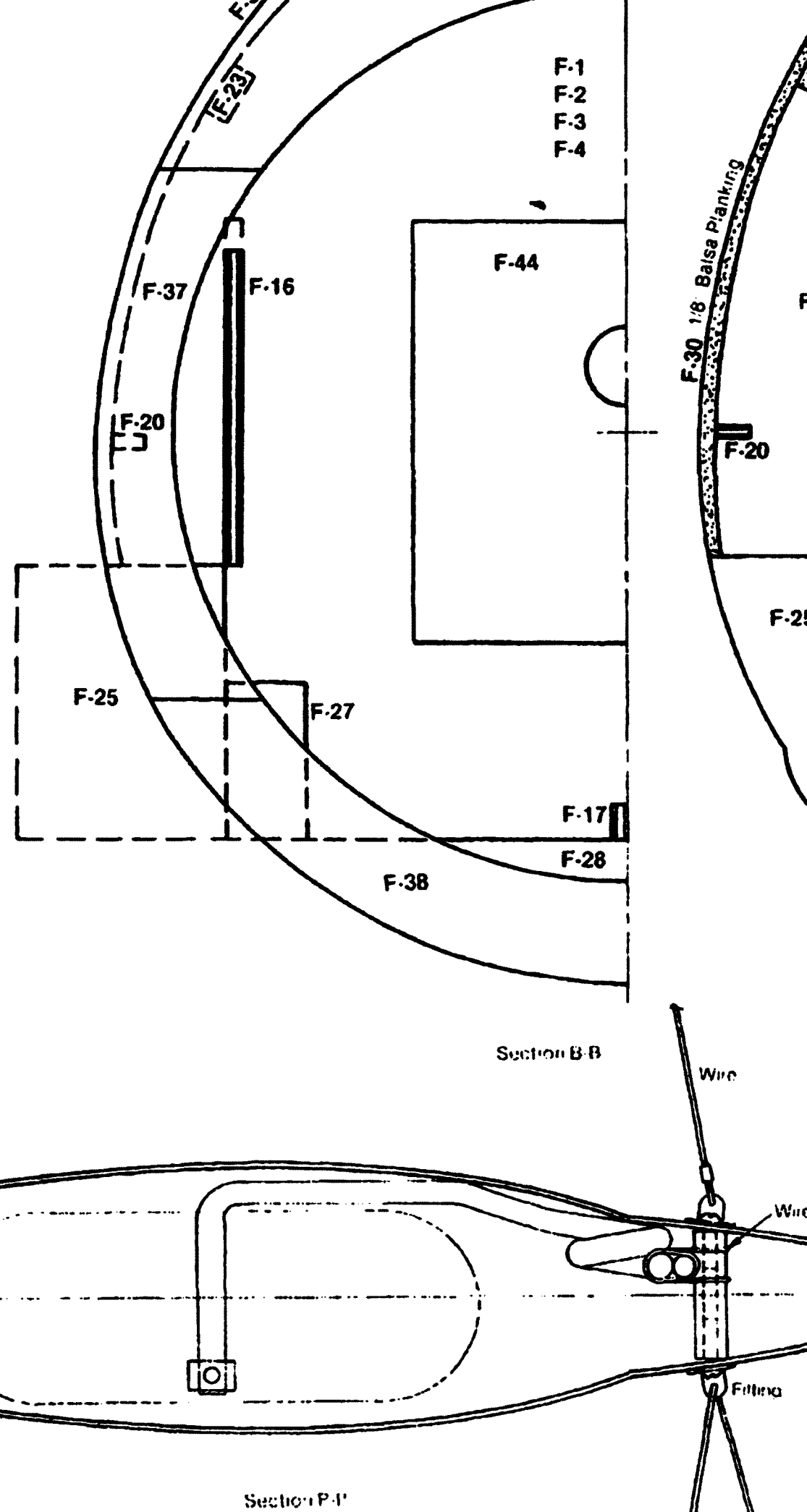
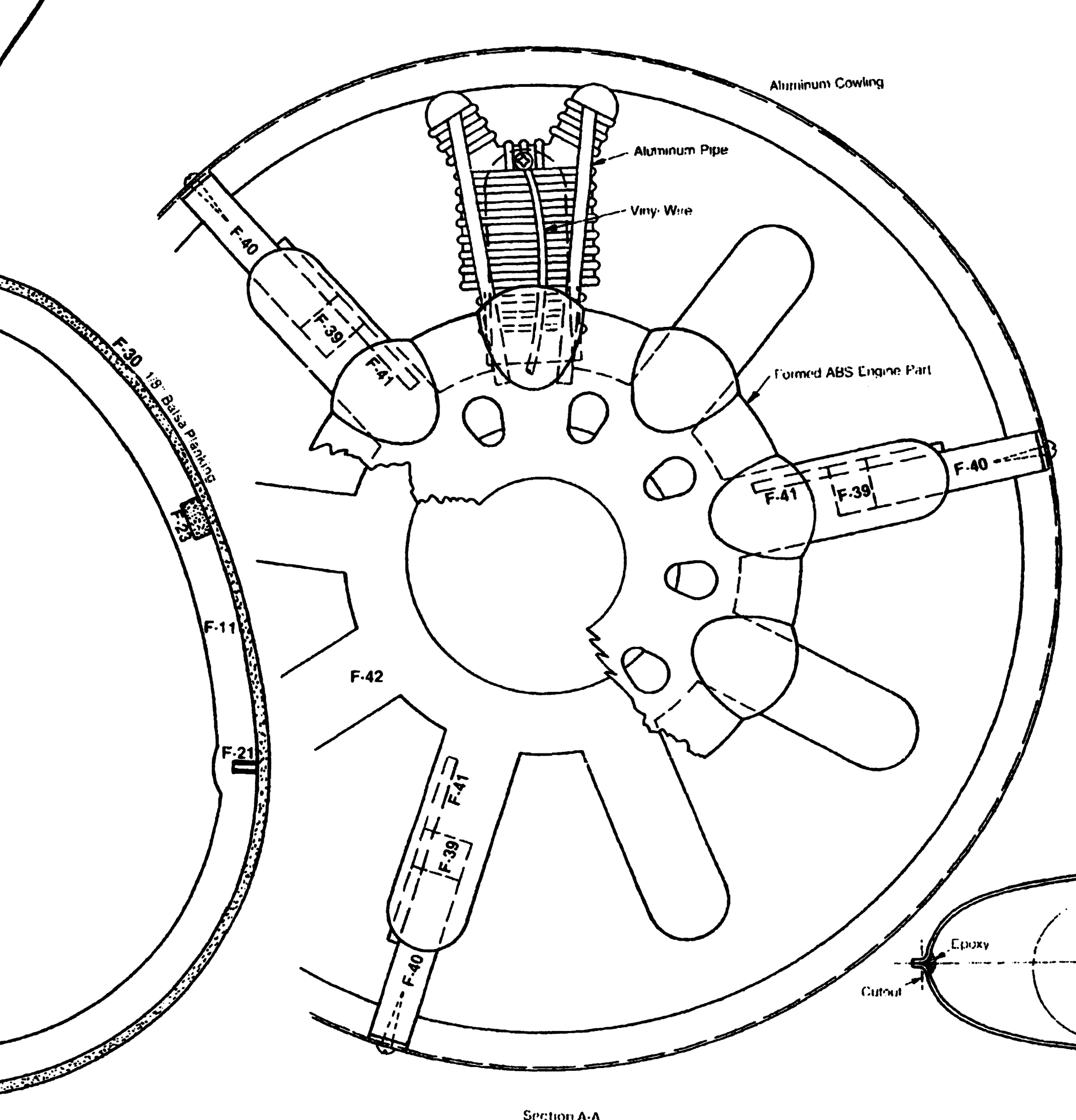
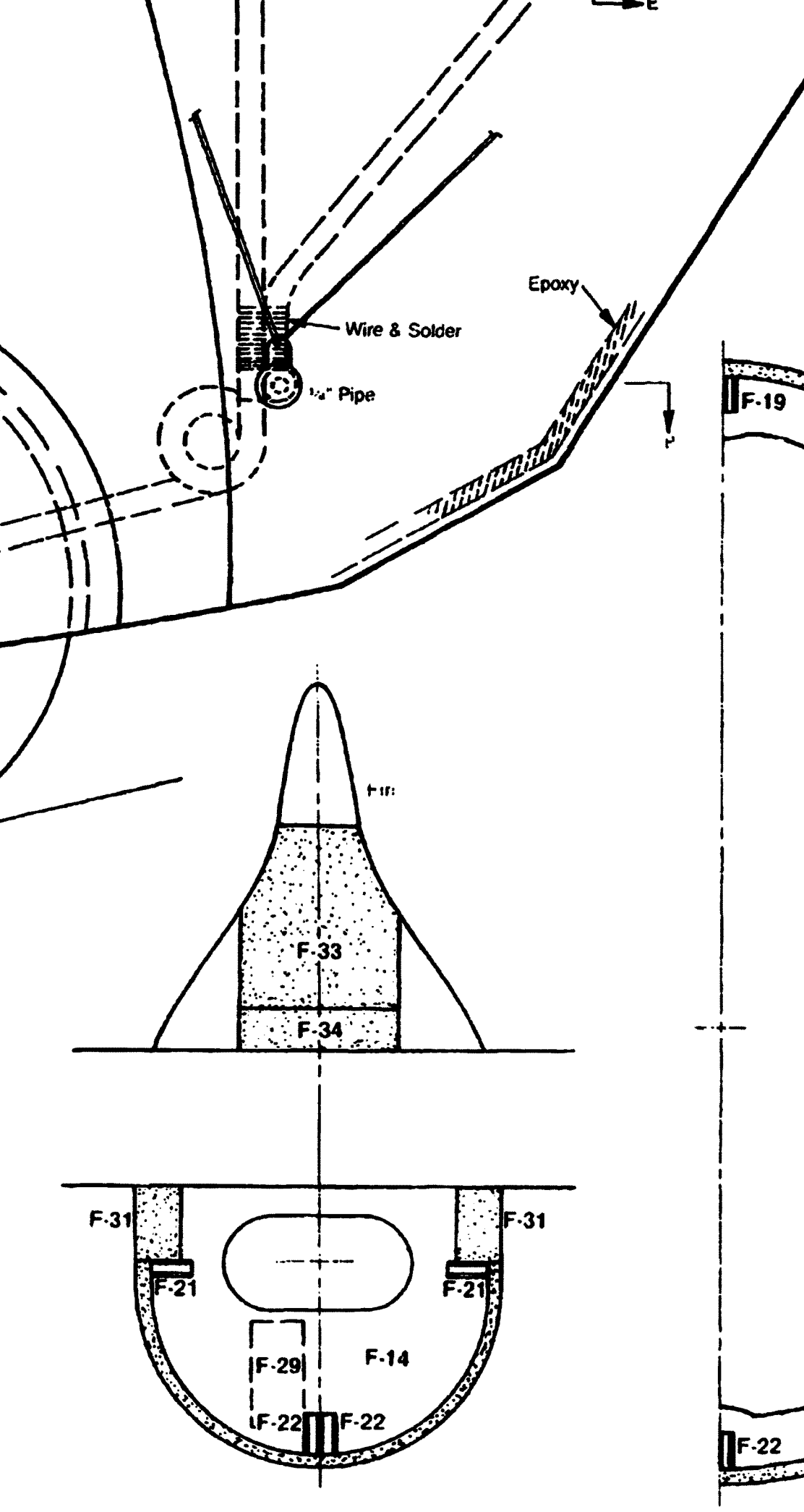
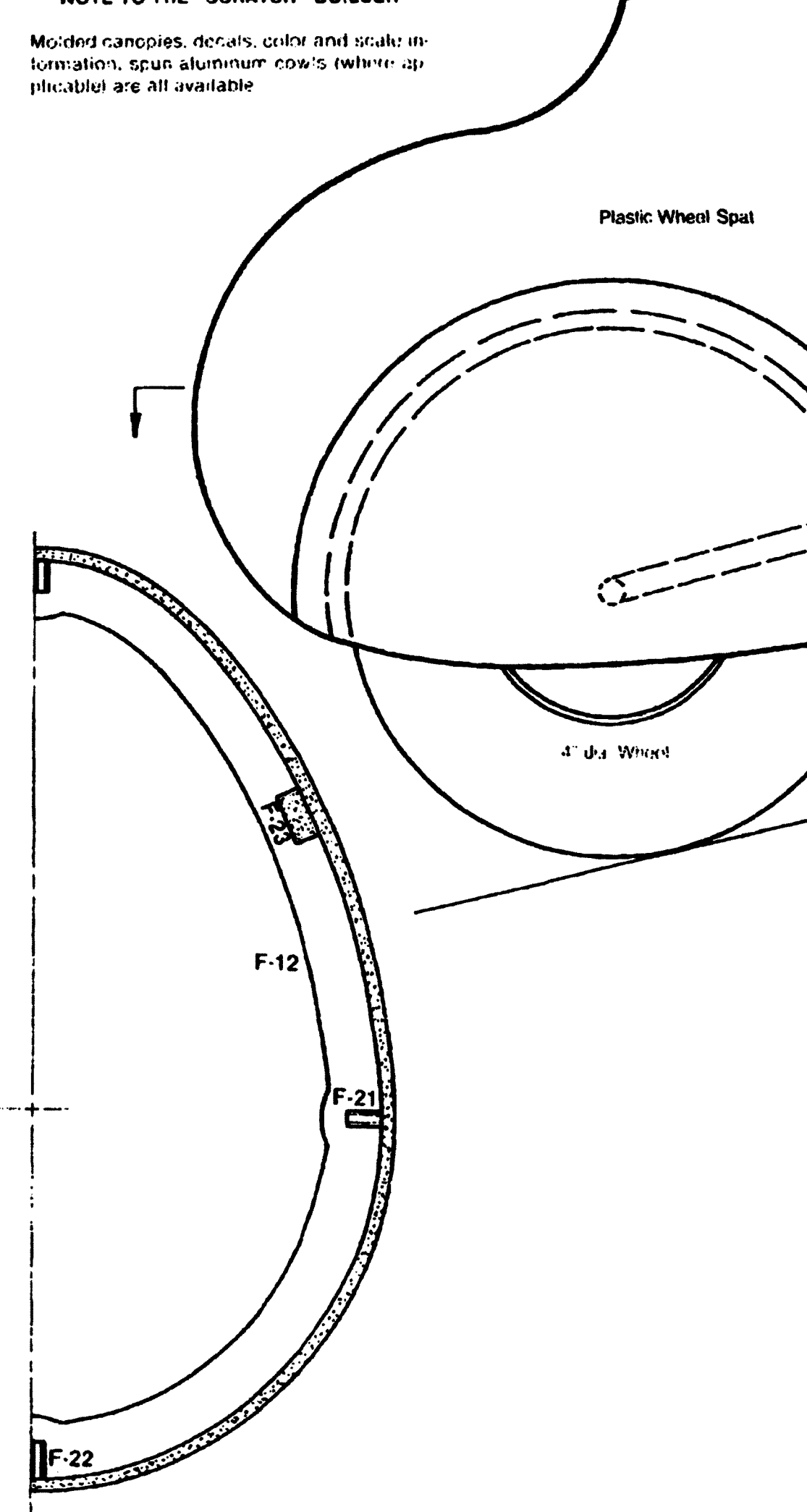
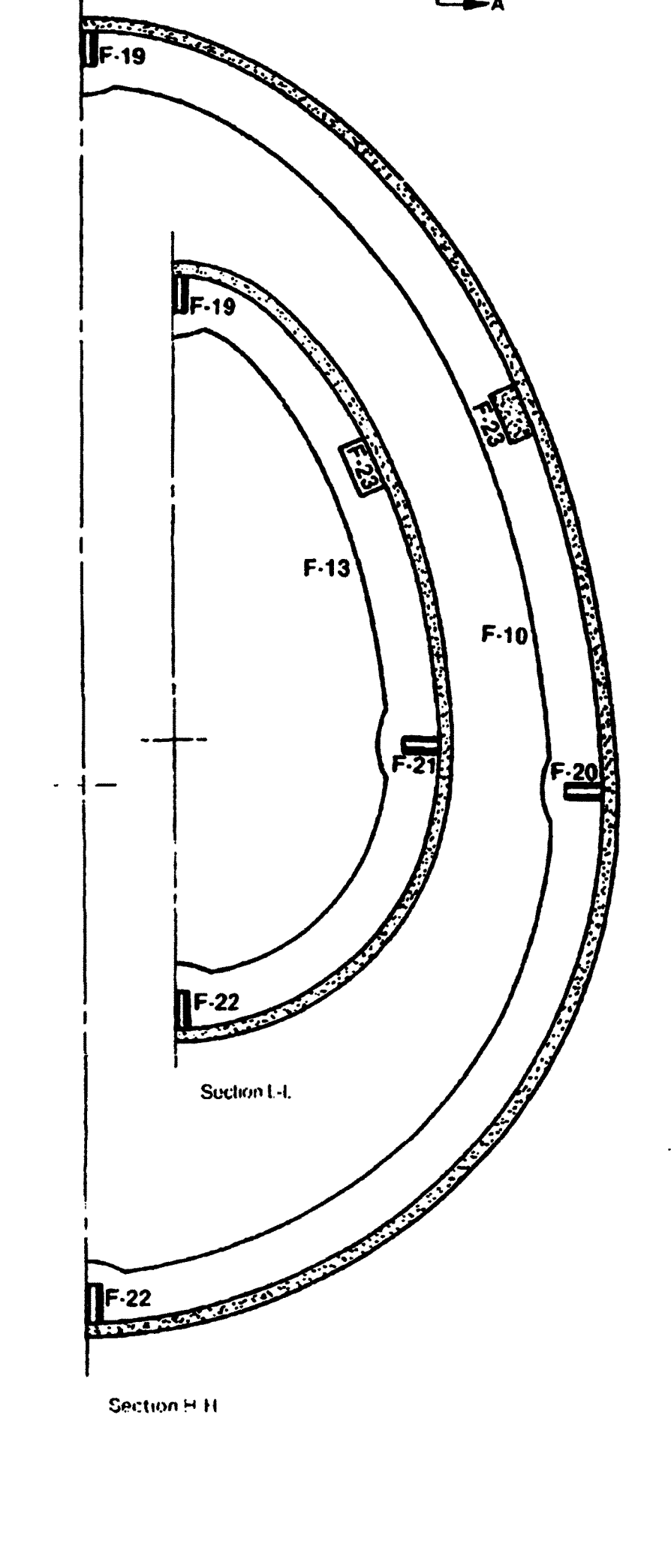

**BOEING**  
**P-26A**  
**"PEASHOOTER"**

