

FUSELAGE TOP VIEW



FUSELAGE BOTTOM VIEW

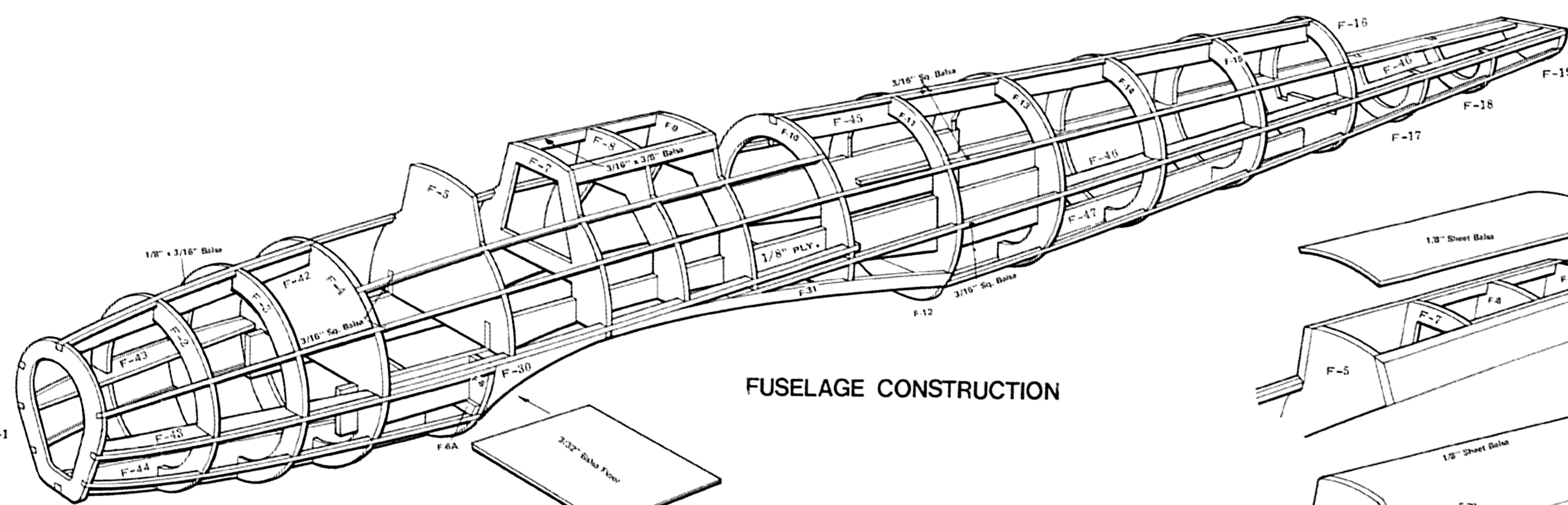

FUSELAGE CONSTRUCTION

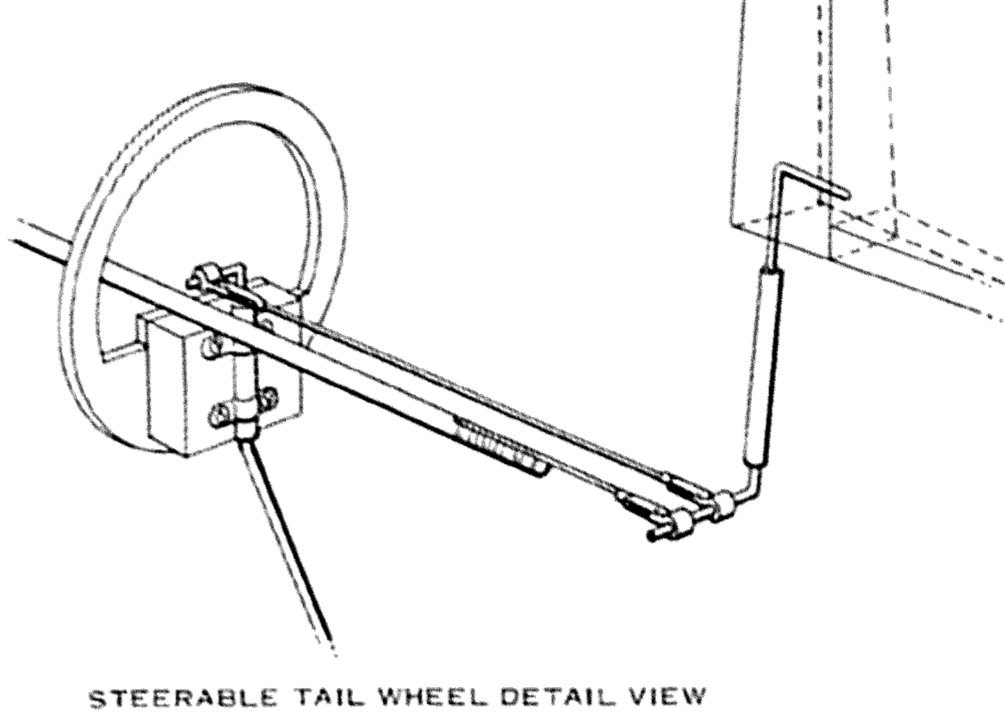

STEERABLE TAIL WHEEL DETAIL VIEW

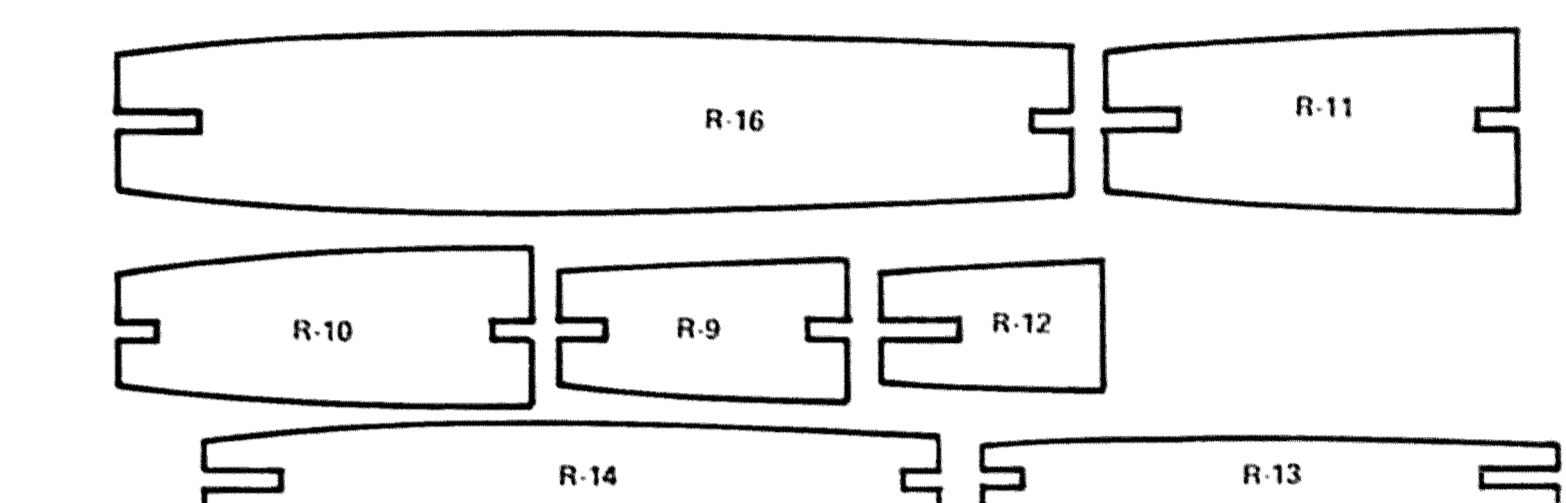

FIN & RUDDER CONSTRUCTION

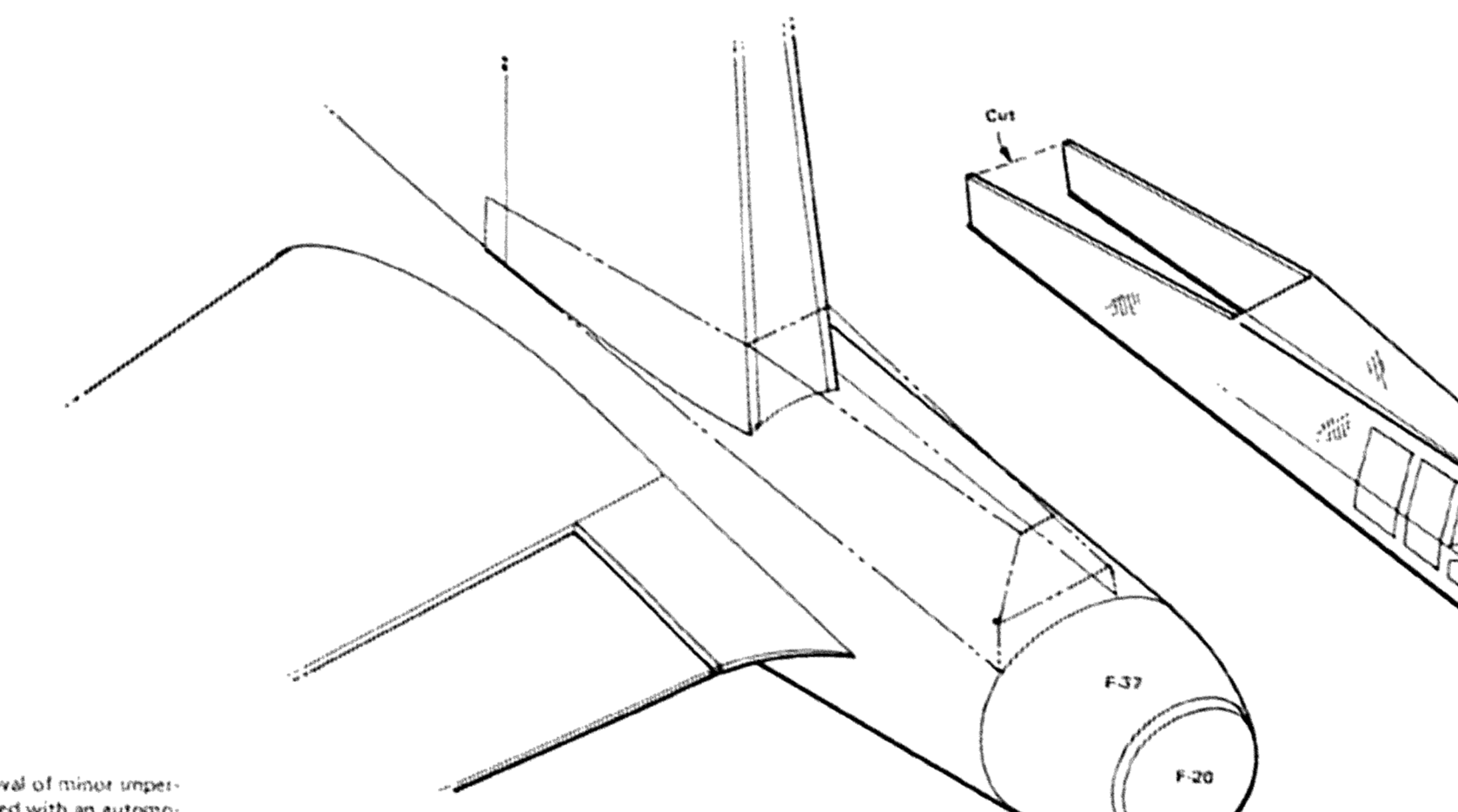
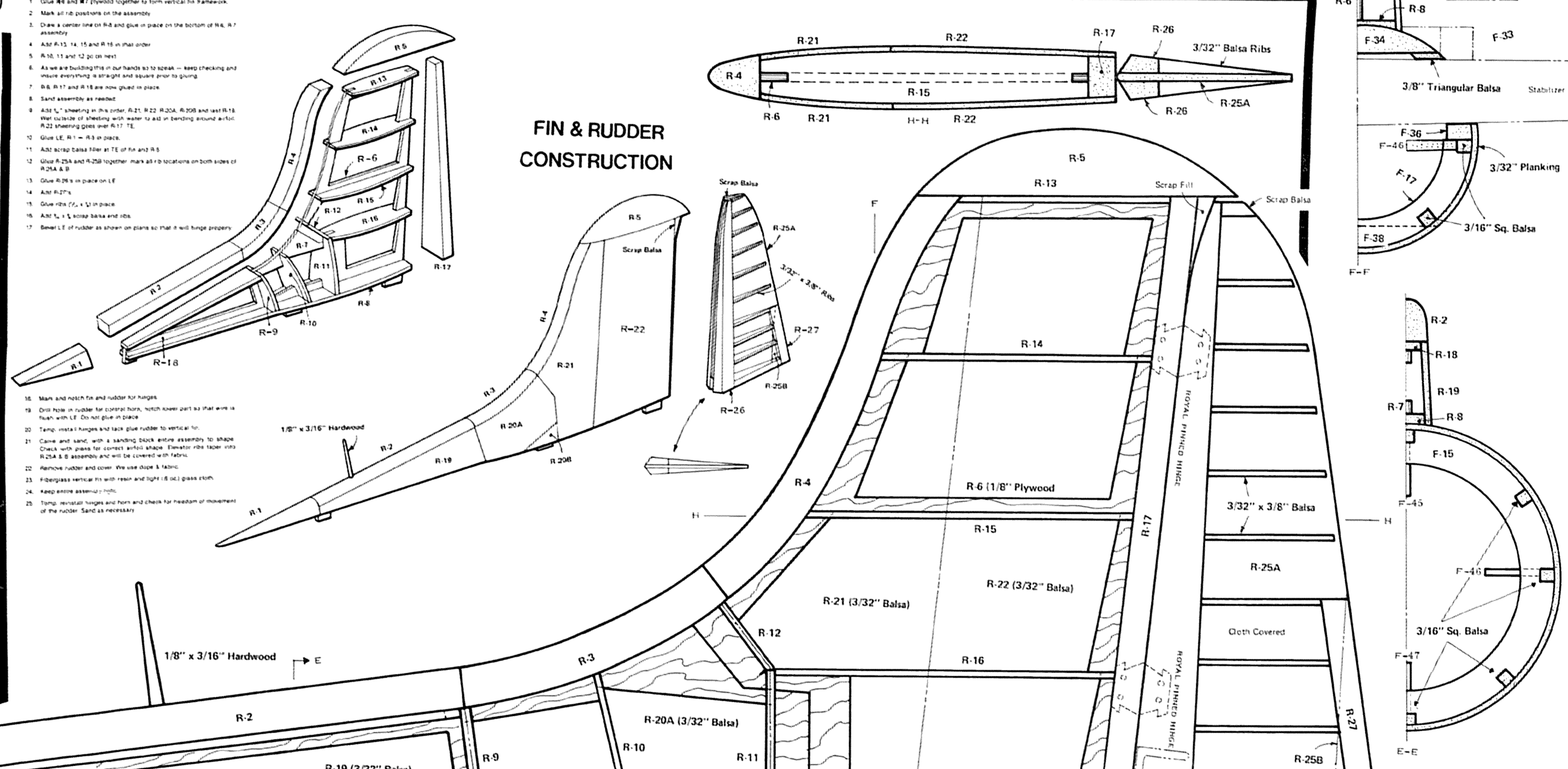

TAIL GUNNERS CANOPY DETAIL VIEW

CANOPY & TURRET NOTES

- 1. For all canopy and turret to assemble use a 1/8" sheet of plywood and glue.
2. The glue cut material areas...
3. The tail gunner turret is built on the upper rib...
4. The turret is built on the upper rib...
5. The turret is built on the upper rib...
6. The turret is built on the upper rib...

NOTE

For greater clarity and the removal of most sections, the canopy may be assembled with an auxiliary tail gunner turret. For several applications, both inside and out, allowing 24 hours drying time be taken. Delimiting. Be sure to clean and remove wax on surface of canopy that is to be glued to the fuselage.

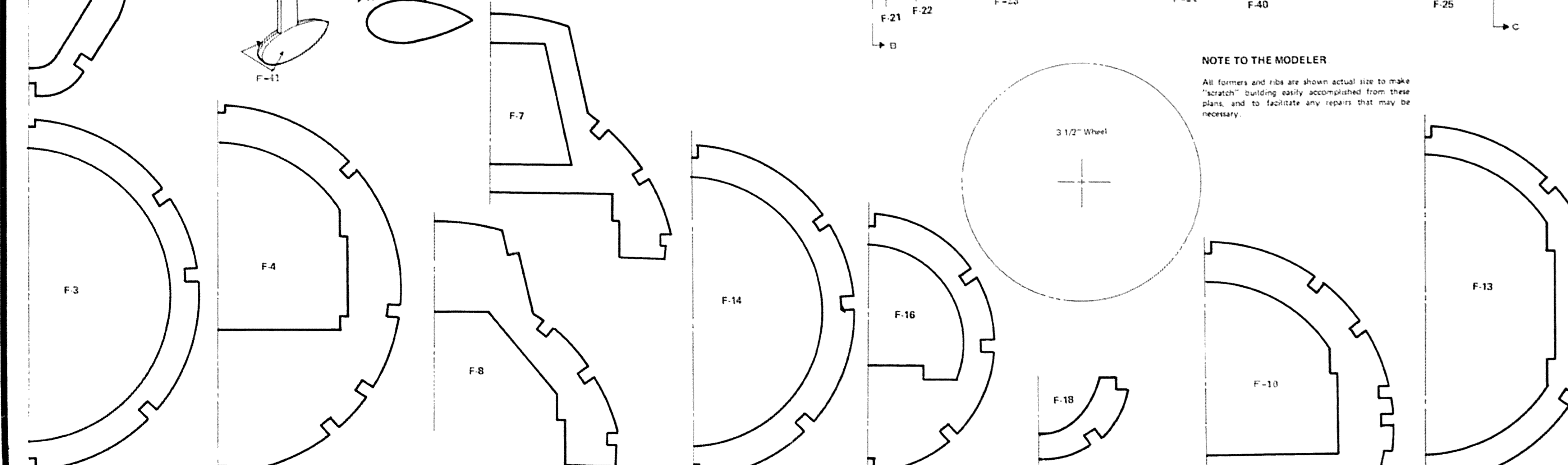

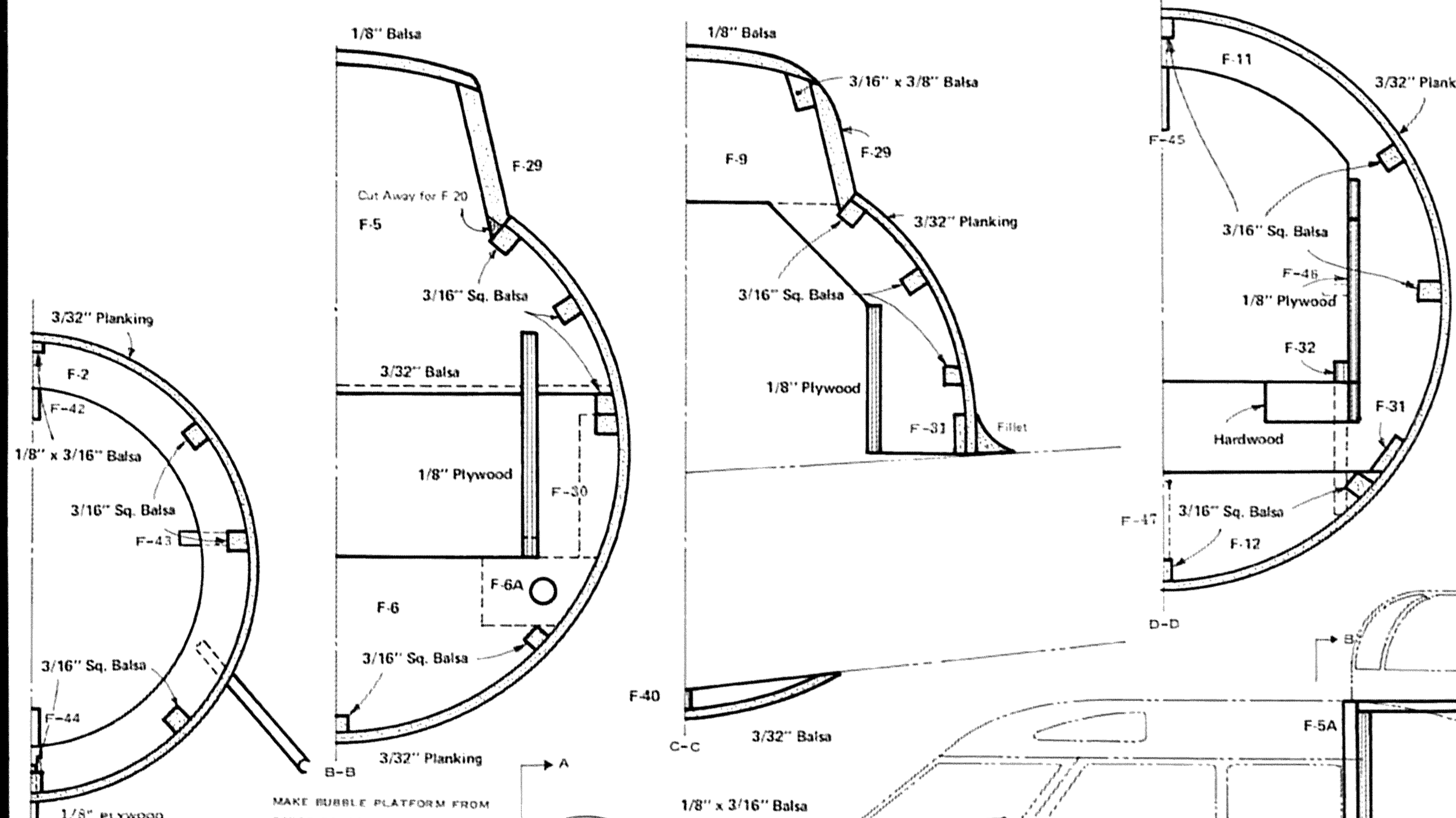

NOTE TO THE MODELER

All formers and ribs are shown actual size to make "aircraft" building easily accomplished from these plans, and to facilitate any repairs that may be necessary.



B-17F Flying Fortress

ROYAL PRODUCTS CORP.

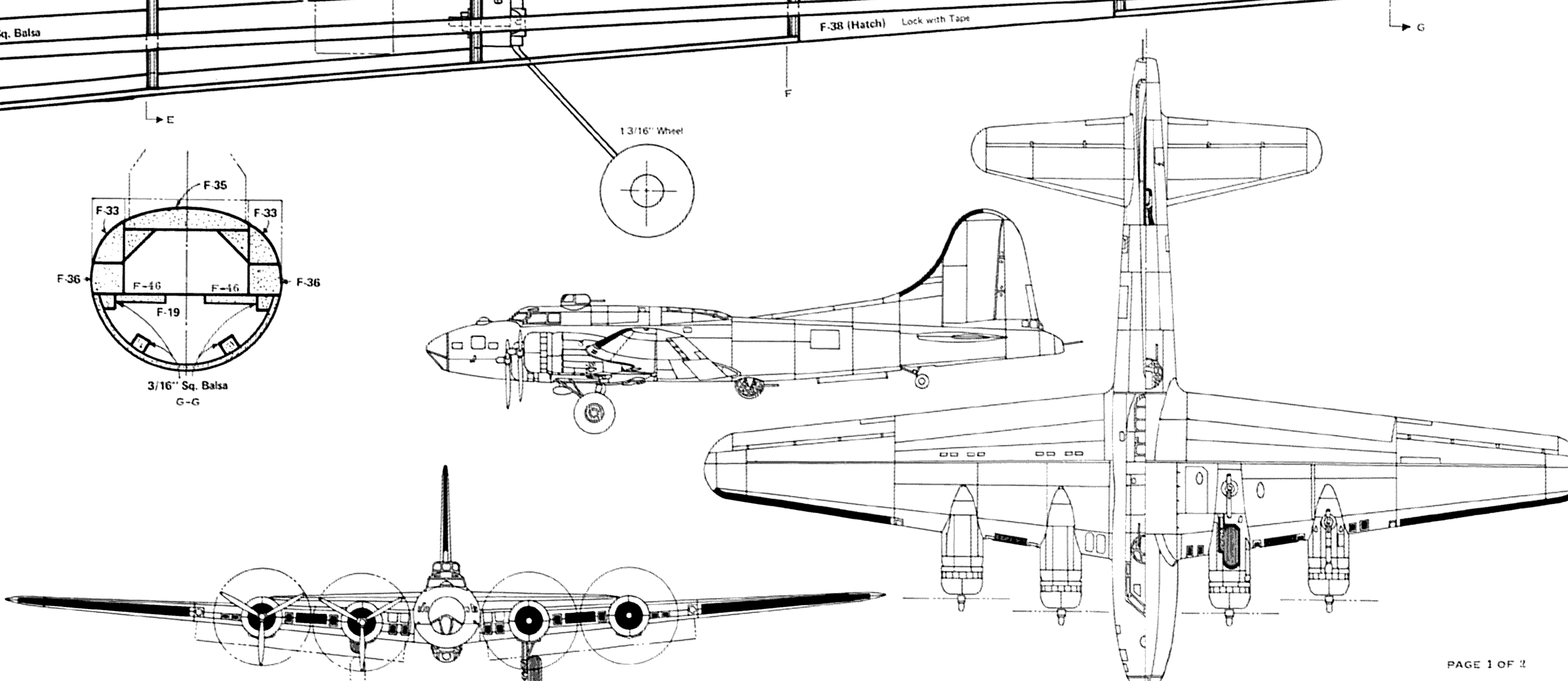



**RETRACT INSTALLATION**

- SUGGESTED RETRACT MODIFICATION**
1. Remove the retract mechanism from the nacelle and clear the area around the retract mechanism.
  2. Remove the retract mechanism from the nacelle and clear the area around the retract mechanism.
  3. Remove the retract mechanism from the nacelle and clear the area around the retract mechanism.
  4. Remove the retract mechanism from the nacelle and clear the area around the retract mechanism.

**WING CONSTRUCTION**

- GENERAL**
1. The wing construction of this model is a light, strong structure made of balsa wood and sheet metal.
  2. The wing is built up in sections, starting with the root and working outwards.
  3. The wing is built up in sections, starting with the root and working outwards.
  4. The wing is built up in sections, starting with the root and working outwards.
- WING CONSTRUCTION**
1. The wing is built up in sections, starting with the root and working outwards.
  2. The wing is built up in sections, starting with the root and working outwards.
  3. The wing is built up in sections, starting with the root and working outwards.
  4. The wing is built up in sections, starting with the root and working outwards.

**NACELLES - BUILDING**

1. We have given a few parts for the four nacelles and the landing gear.
2. We have given a few parts for the four nacelles and the landing gear.
3. We have given a few parts for the four nacelles and the landing gear.
4. We have given a few parts for the four nacelles and the landing gear.

**NACELLES - INSTALLATION**

1. Remove the nacelle from the fuselage. Make a number on the back of the nacelle to correspond to the number on the fuselage.
2. Remove the nacelle from the fuselage. Make a number on the back of the nacelle to correspond to the number on the fuselage.
3. Remove the nacelle from the fuselage. Make a number on the back of the nacelle to correspond to the number on the fuselage.
4. Remove the nacelle from the fuselage. Make a number on the back of the nacelle to correspond to the number on the fuselage.

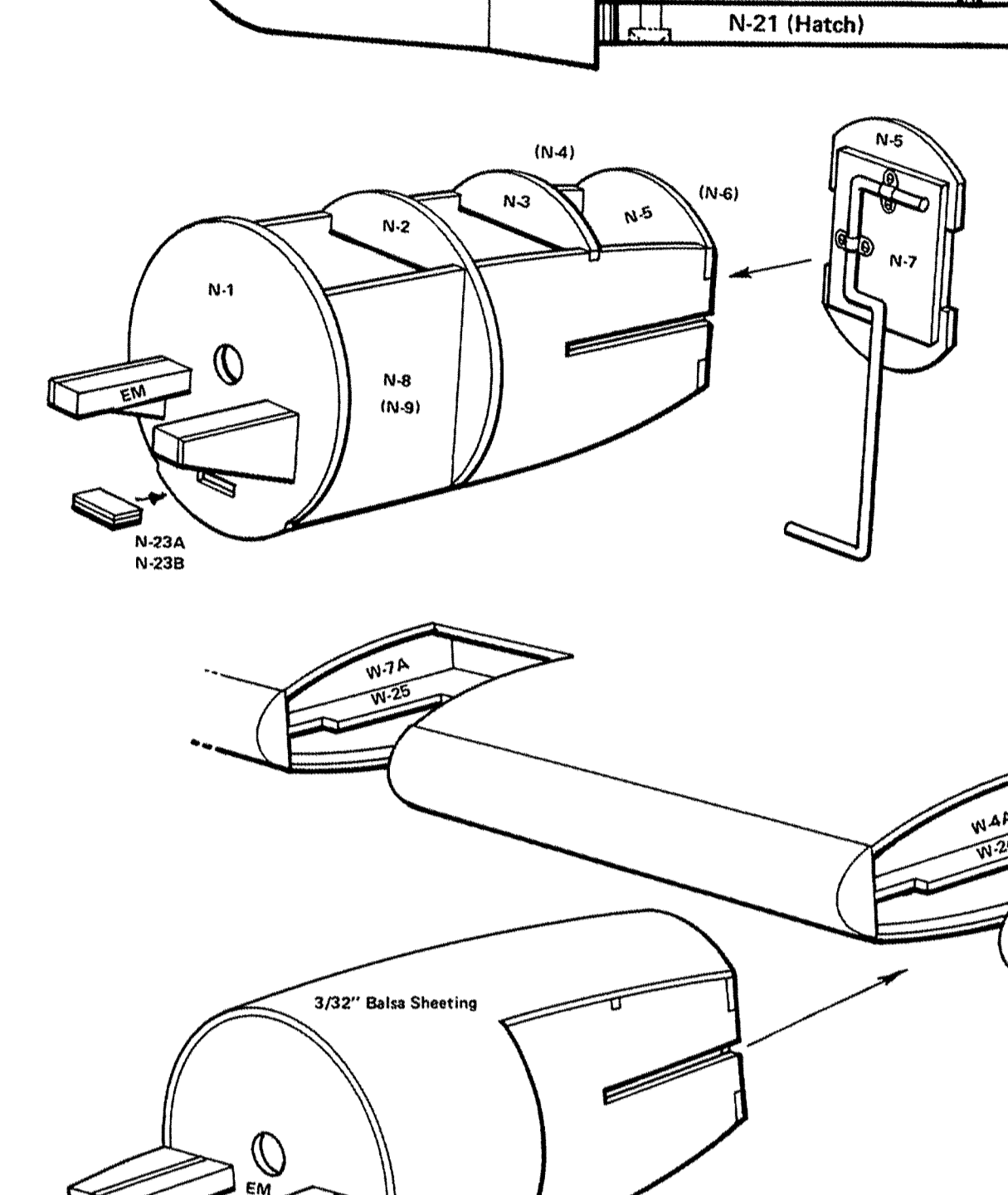

**BUILDER**  
Use information available on all

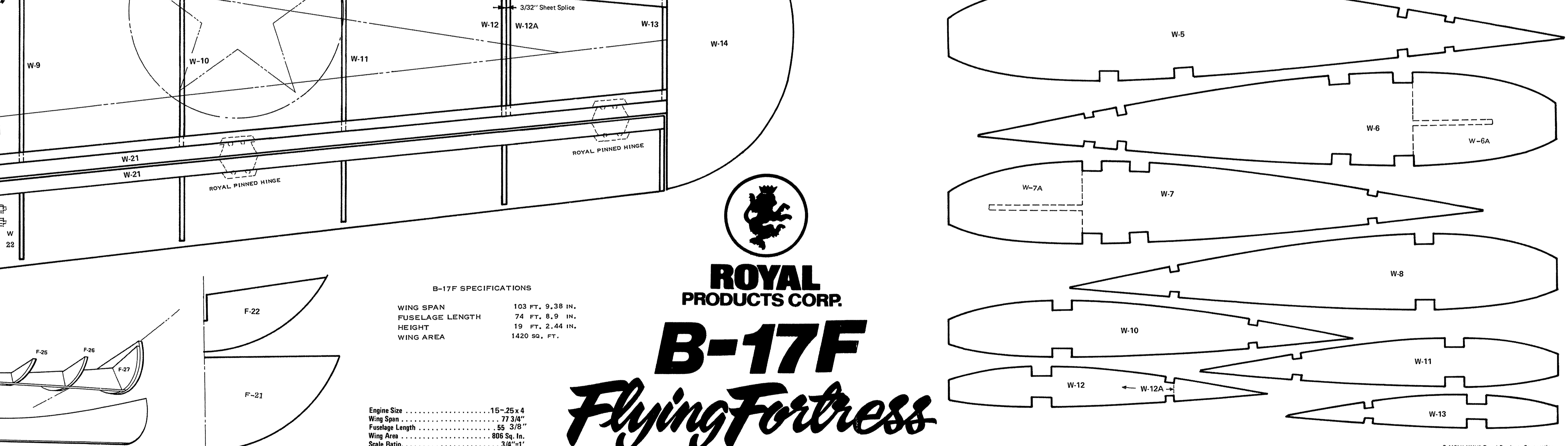
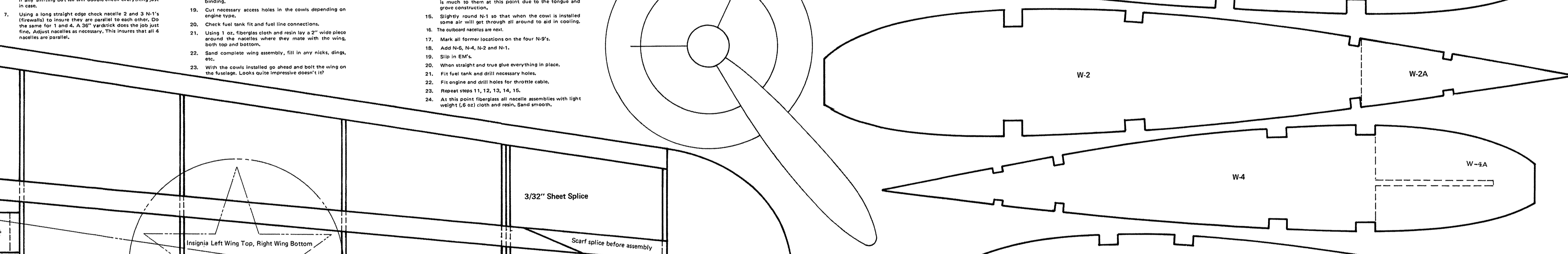
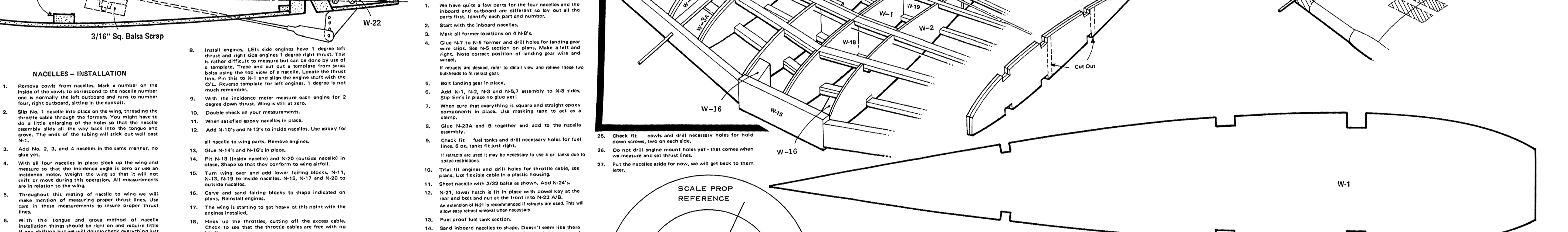
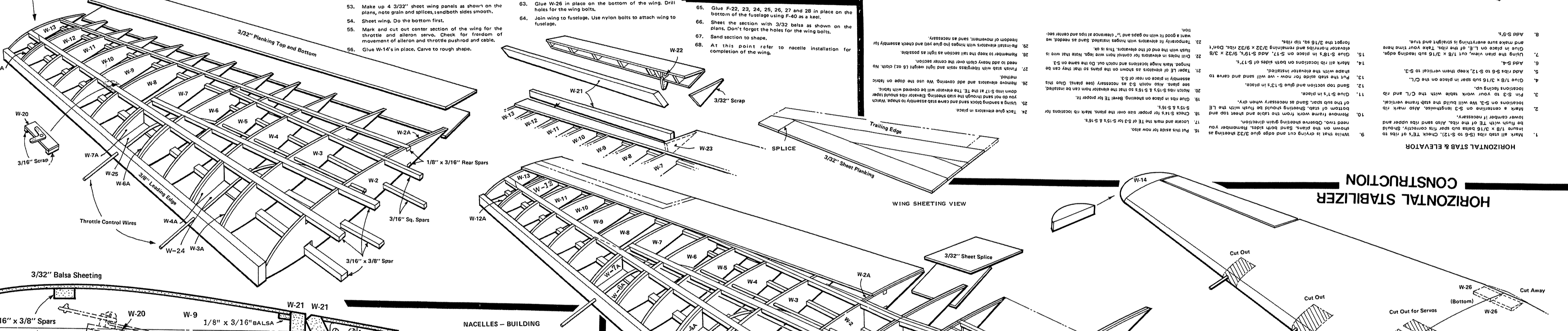
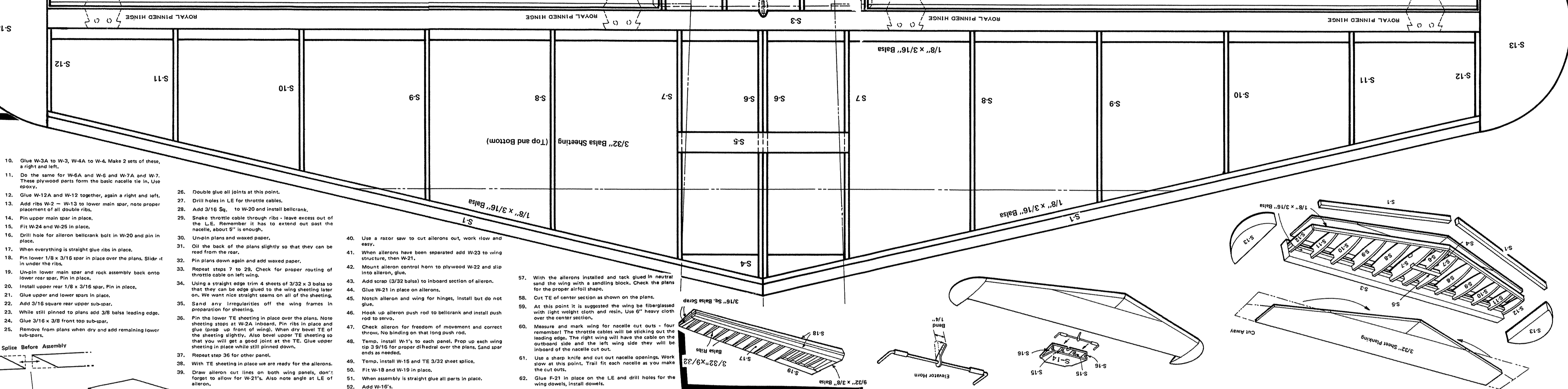
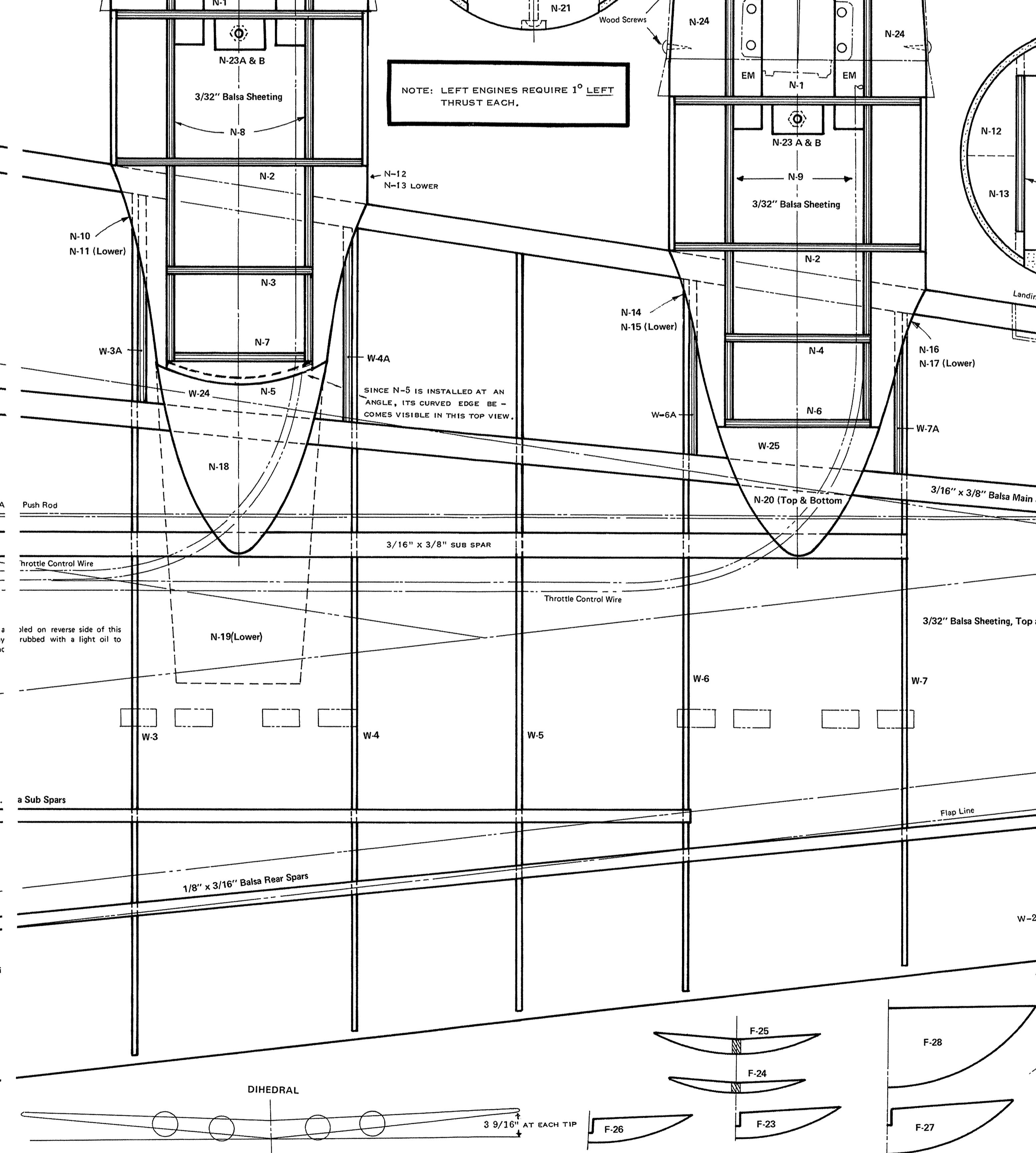
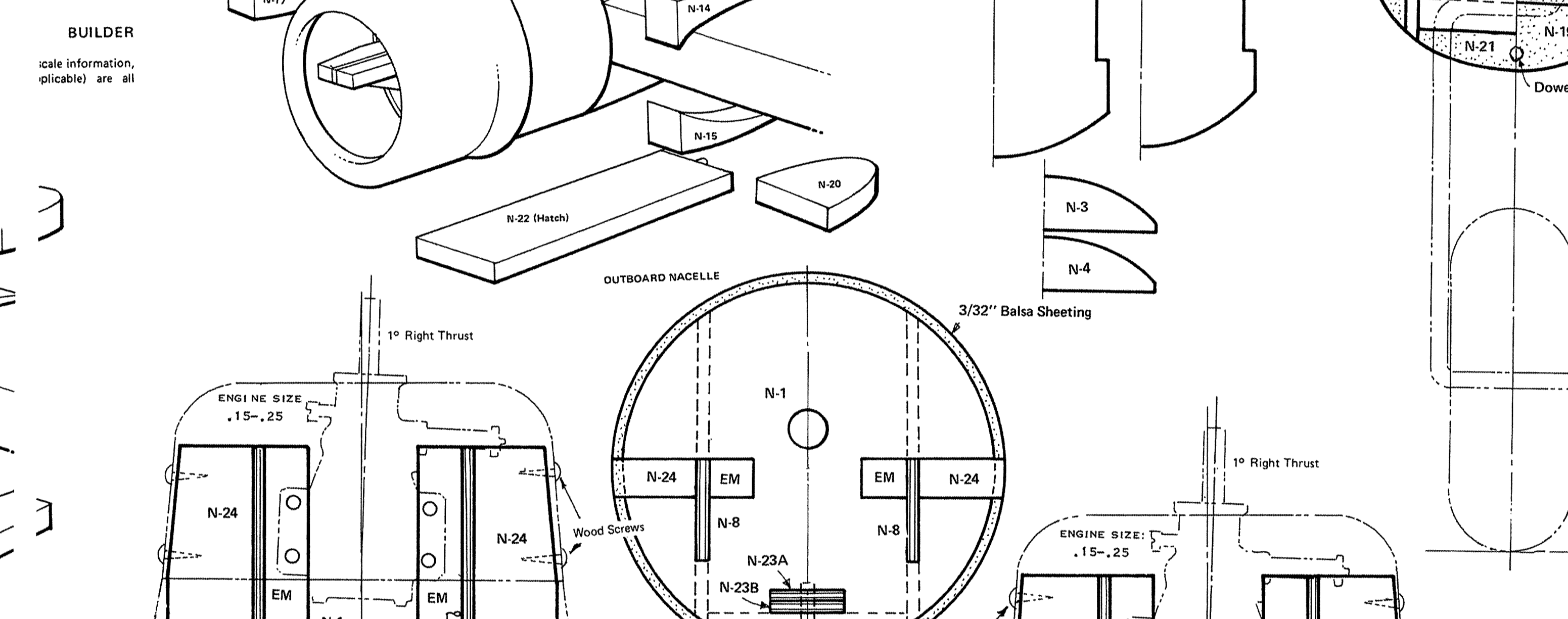
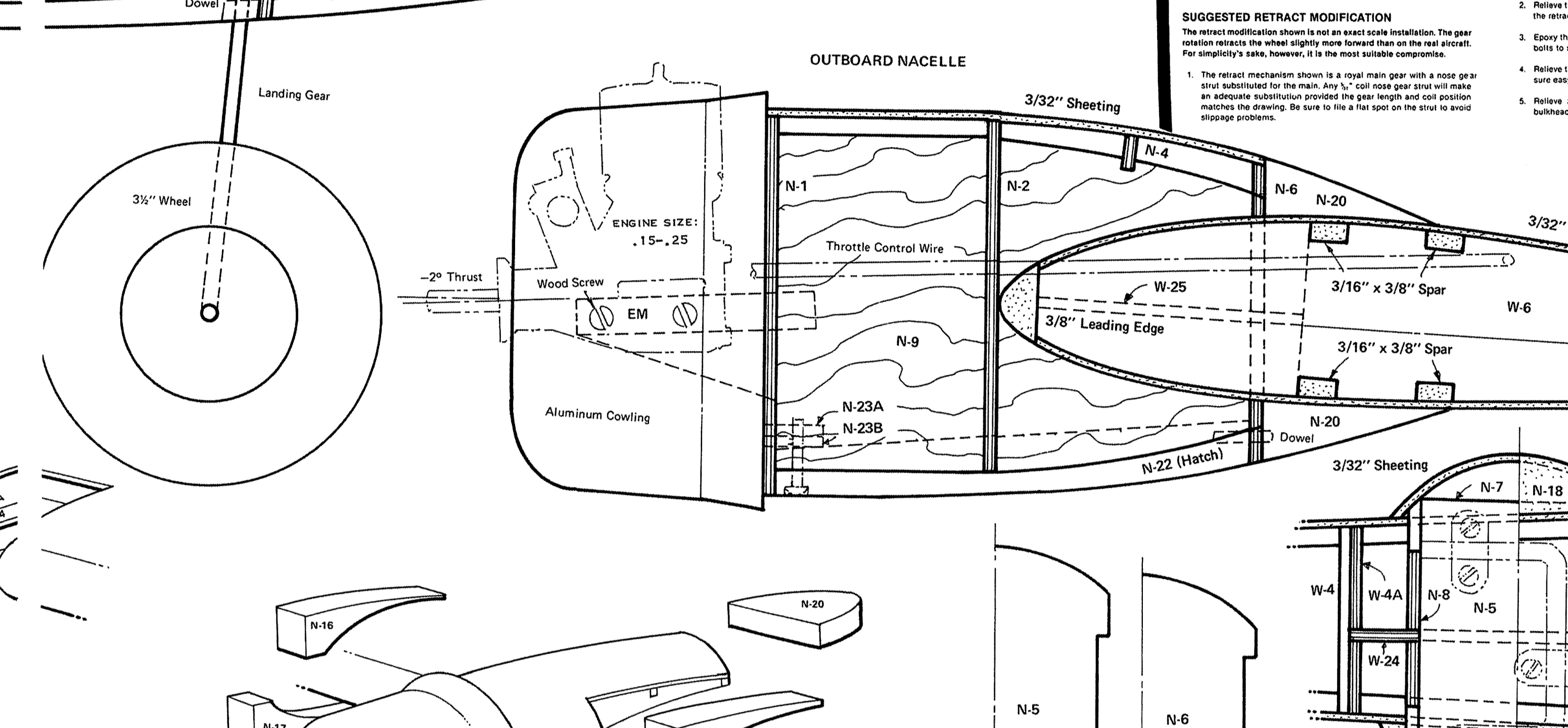
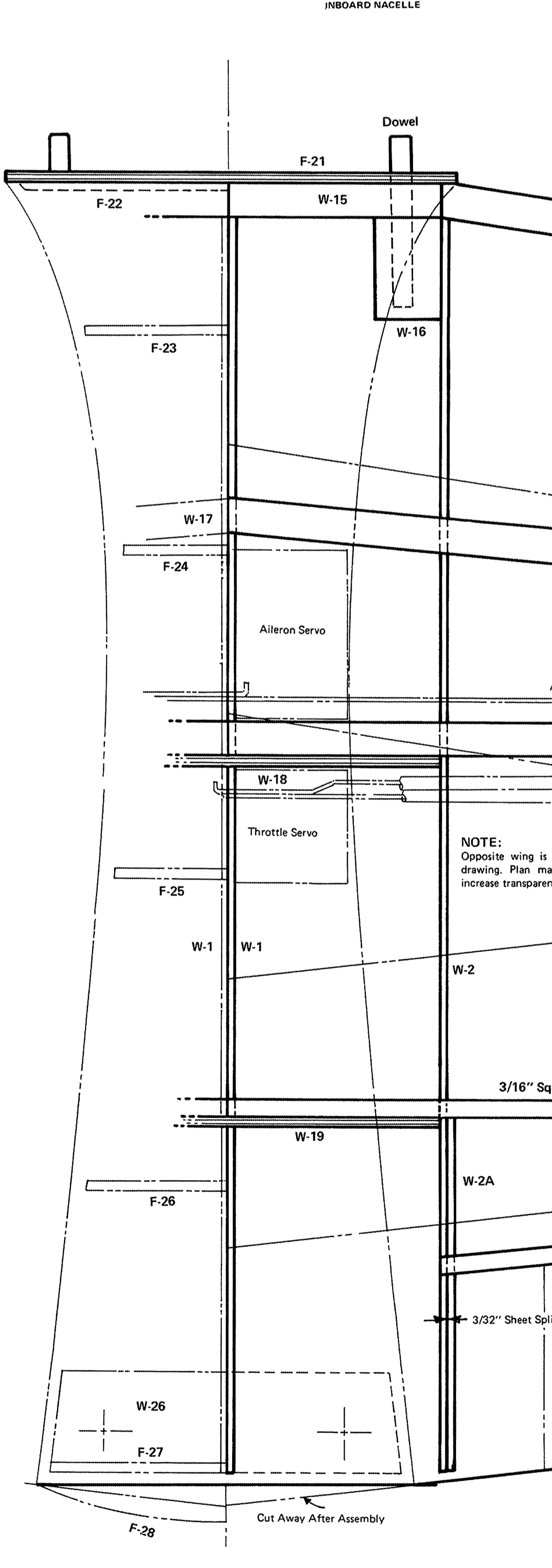
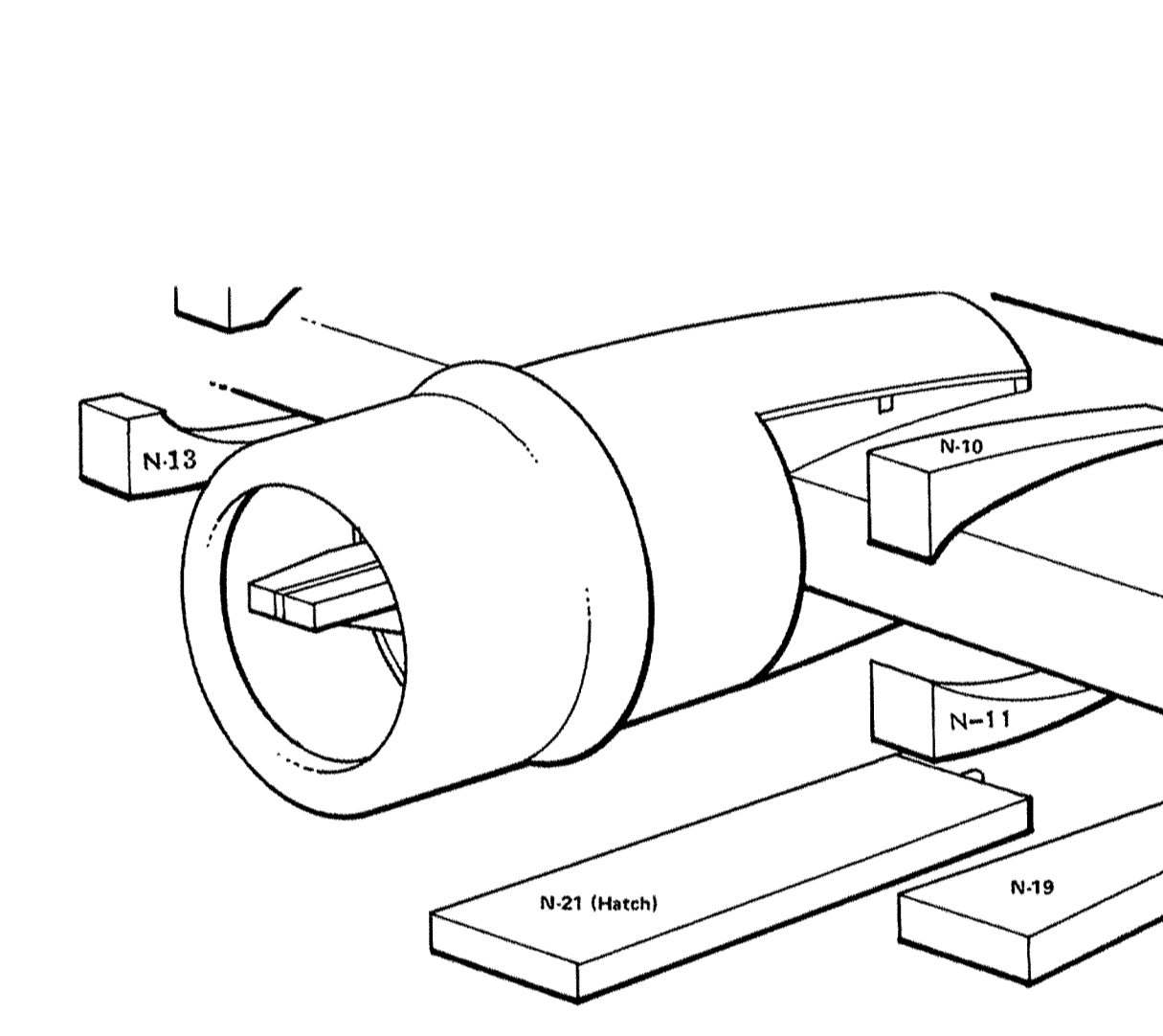

**B-17F SPECIFICATIONS**

|                 |                  |
|-----------------|------------------|
| WING SPAN       | 103 FT. 9.38 IN. |
| FUSELAGE LENGTH | 74 FT. 8.9 IN.   |
| HEIGHT          | 19 FT. 2.44 IN.  |
| WING AREA       | 1420 SQ. FT.     |

