

QUERRIDERANLENKUNG AN DAS AULÖTEN
Solder the aileron horn on the pipe.
ヒアノ線と真鍮パイプをハンダ付けする(向きに注意)

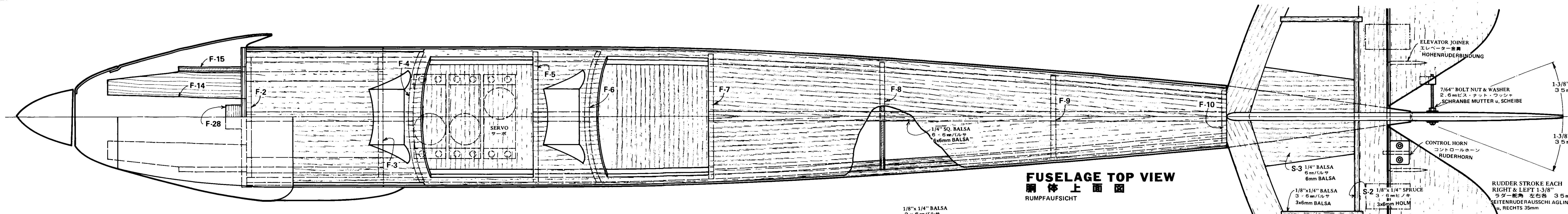

FUSELAGE TOP VIEW
胴体上面図
RUMPPAUF SICHT

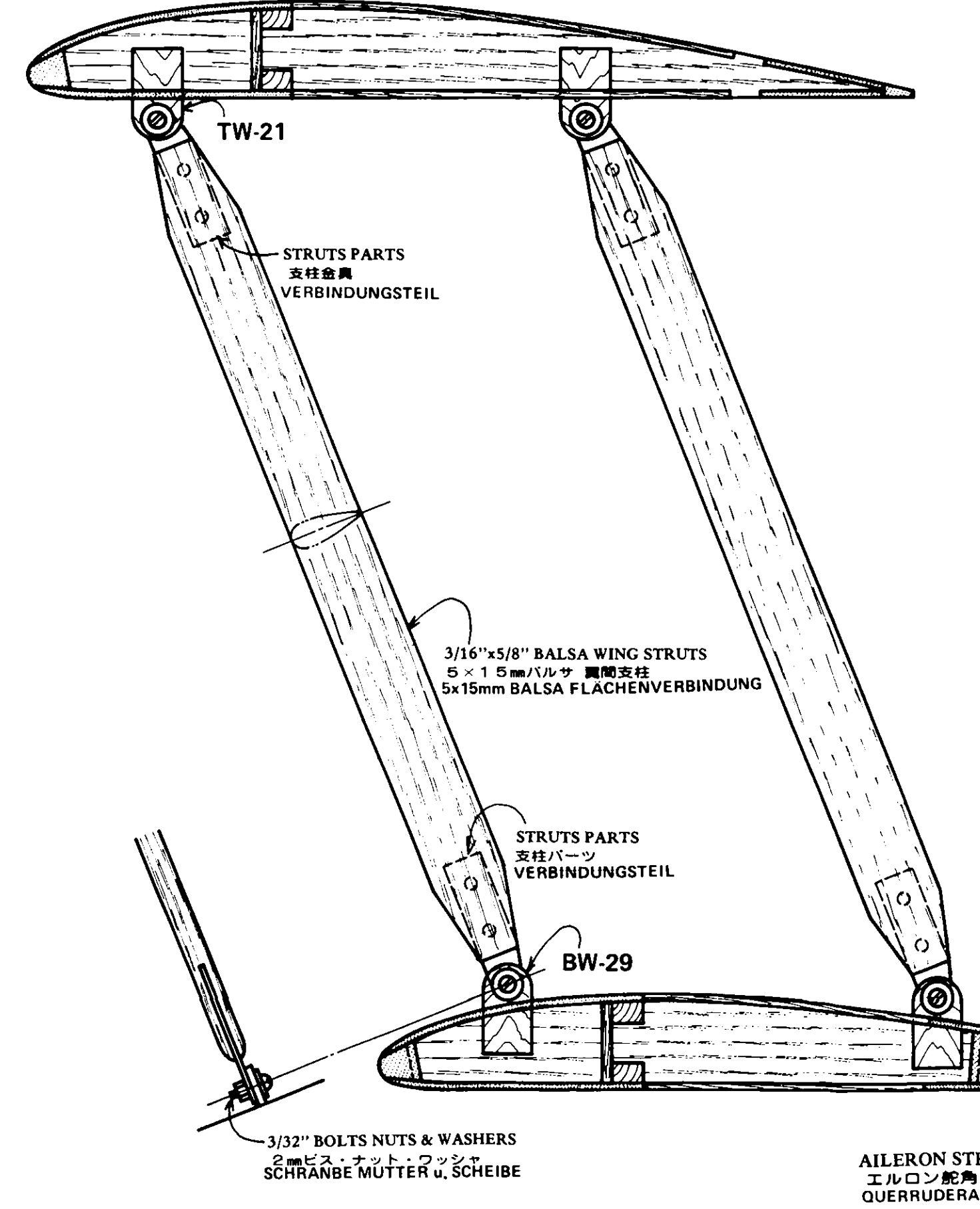

SEC. C

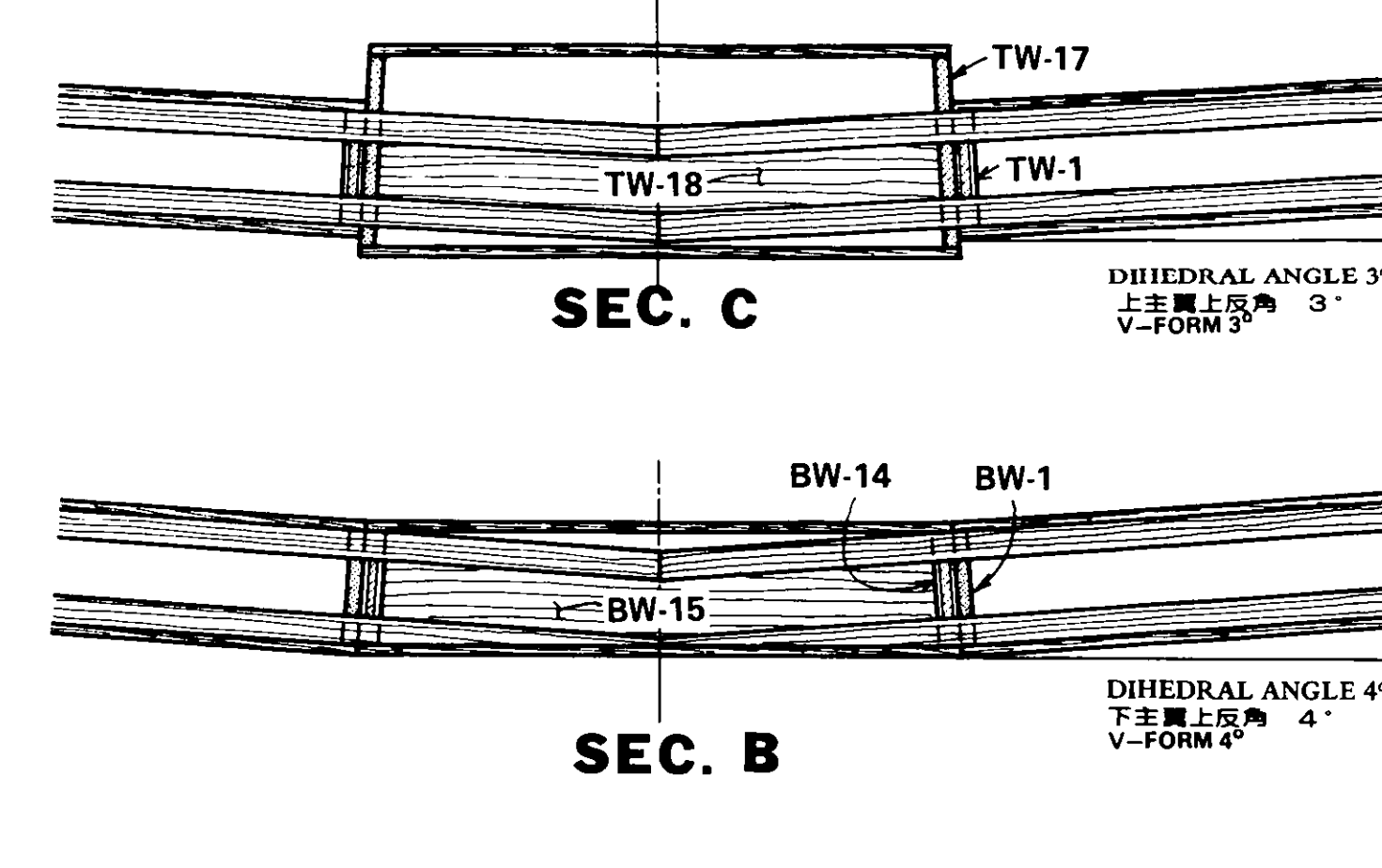

SEC. C

SEC. B

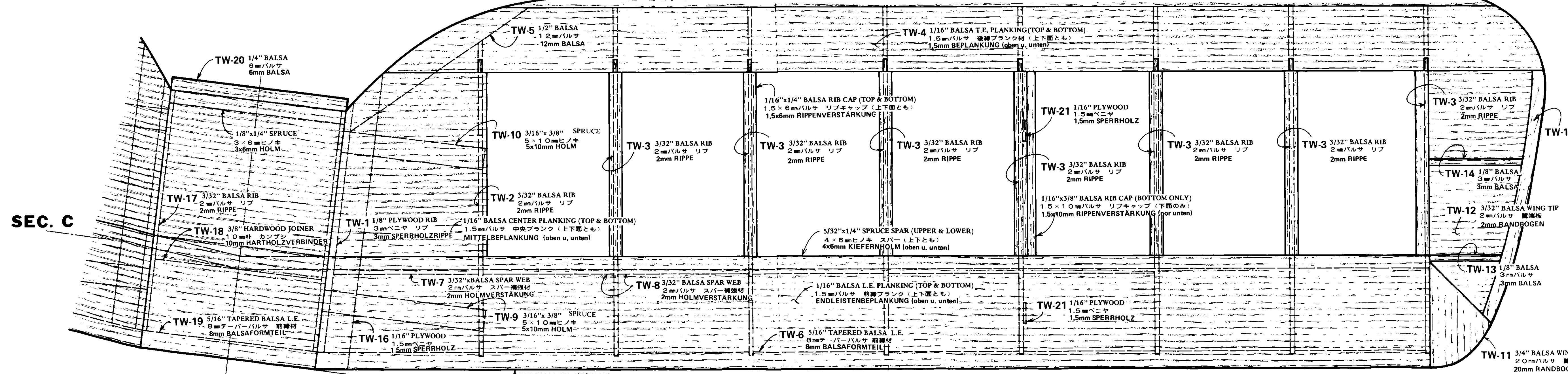

TOP WING PANEL 上主翼平面図 OBER FLÄCHE

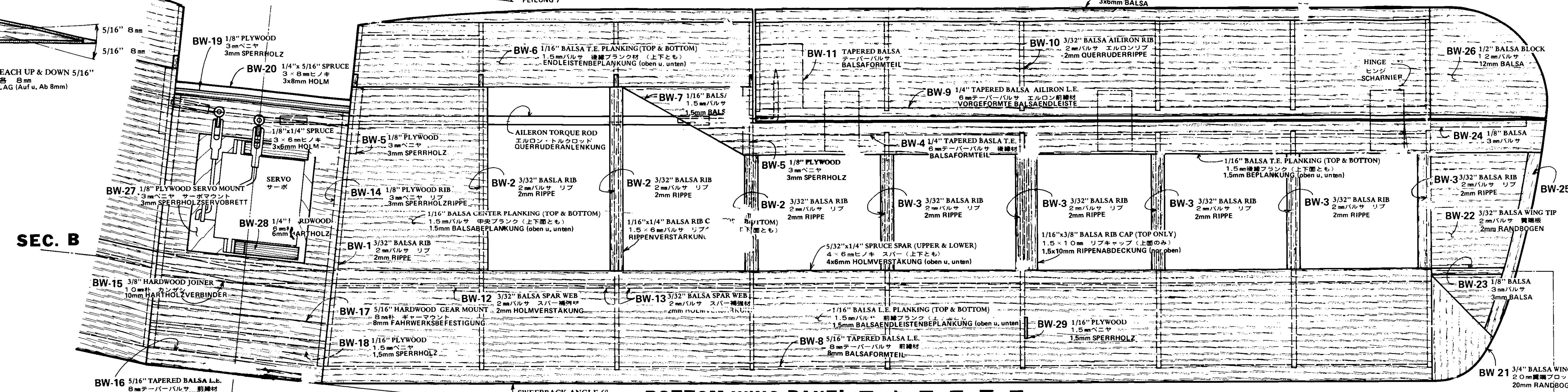

BOTTOM WING PANEL 下主翼平面図 UNTERE FLÄCHE

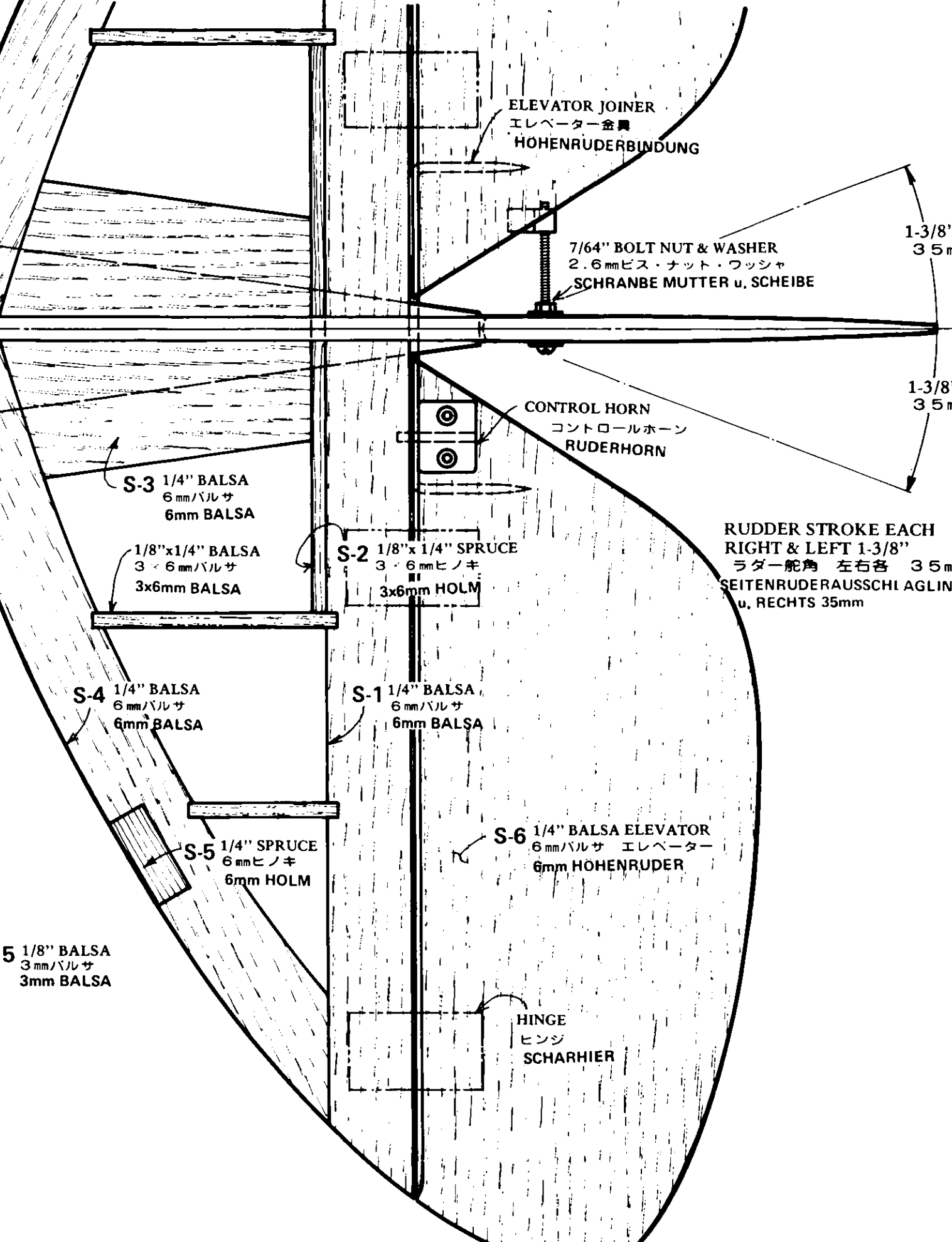

STABILIZER TOP VIEW
尾翼上面図
HOHENRUDERAUF SICHT

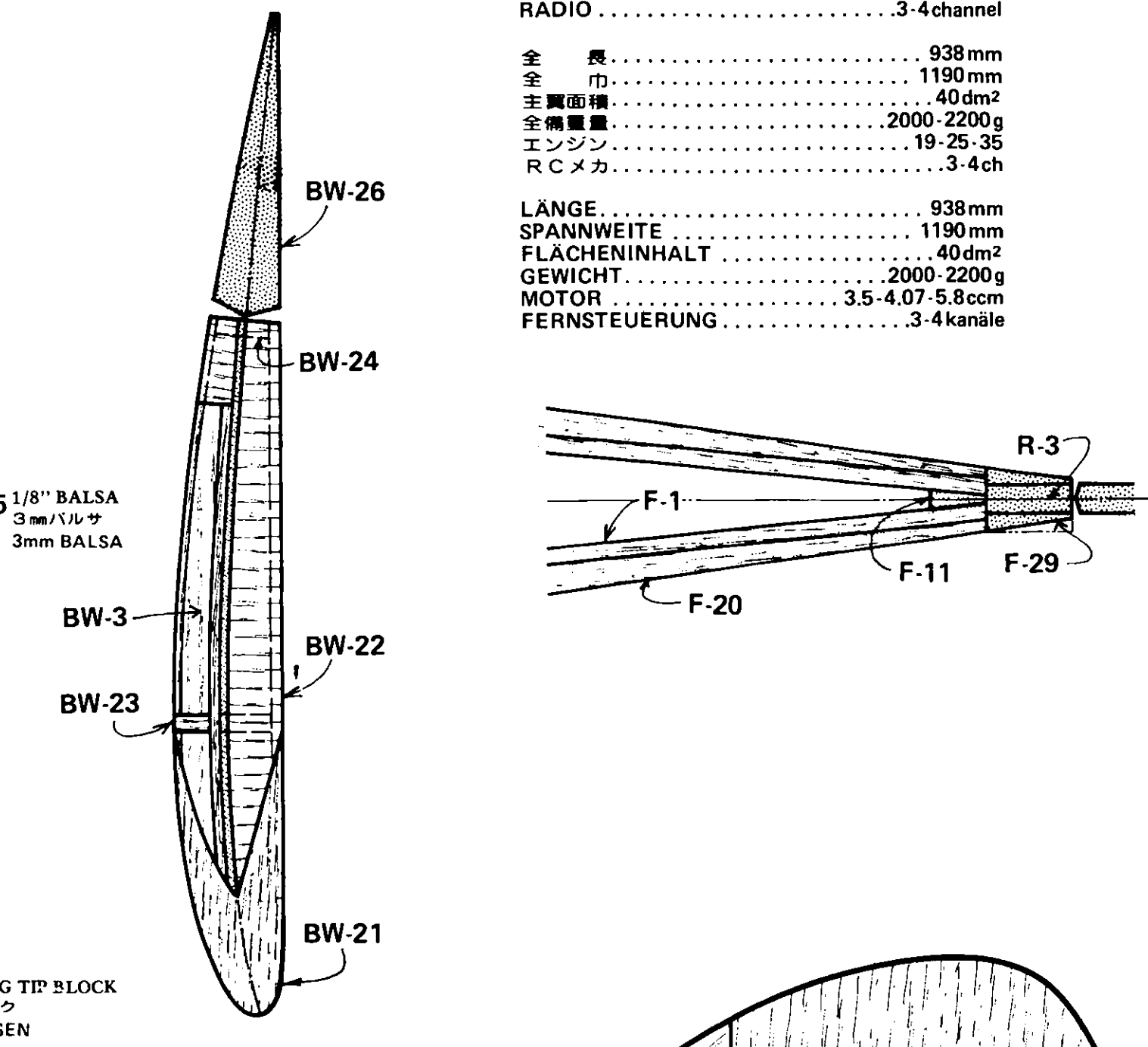

LENGTH	37 inches
WING SPAN	47 inches
WING AREA	620 sq. in.
WEIGHT	70-77 oz.
ENGINE	19-25 cc
RADIO	3-4 channel
全長	938mm
全幅	1190mm
主翼面積	400cm ²
エンジン	2000-2200cc
エンジン	19-25 cc
RCチャンネル	3-4ch
全長	938mm
全幅	1190mm
主翼面積	400cm ²
エンジン	2000-2200cc
エンジン	19-25 cc
RCチャンネル	3-4ch

19-25-35
2-CYCLE ENGINE
2サイクルエンジン

30-35-40
4-CYCLE ENGINE
4サイクルエンジン

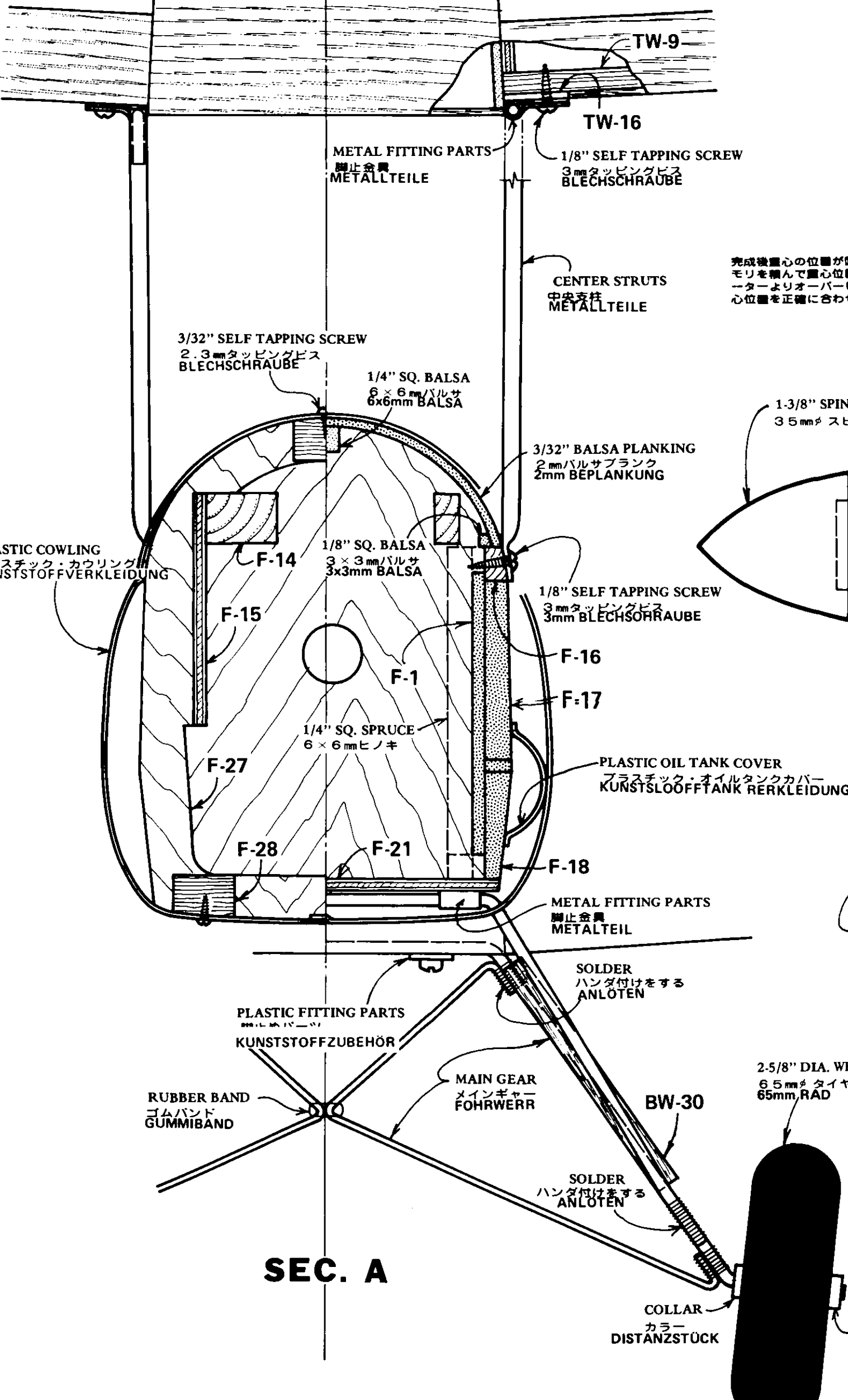

SEC. A

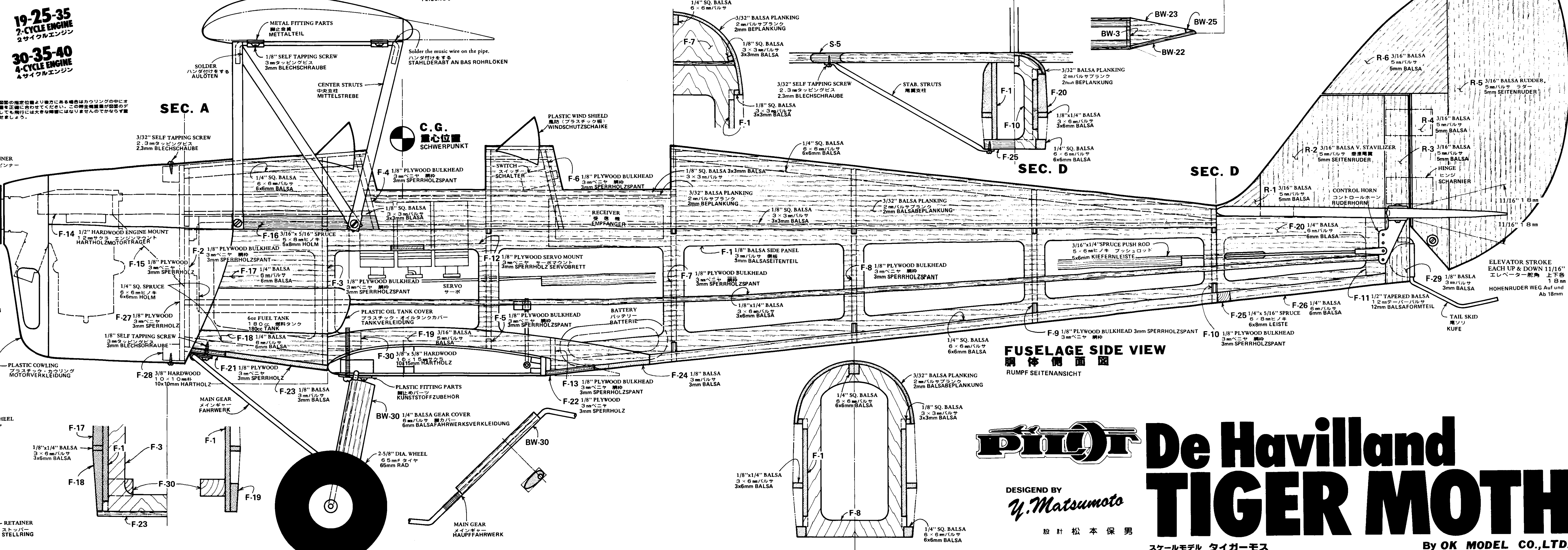

FUSELAGE SIDE VIEW
胴体側面図
RUMPP SEITENANSICHT

PILOT De Havilland TIGER MOTH

DESIGNED BY Y. Matsumoto

設計 松本 保男

スケールモデル タイガーモス

By OK MODEL CO., LTD.

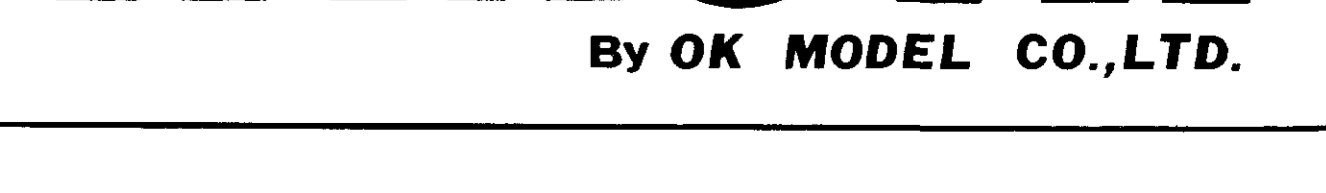
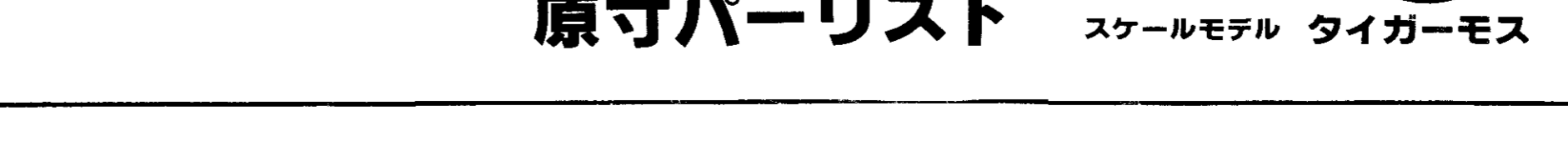
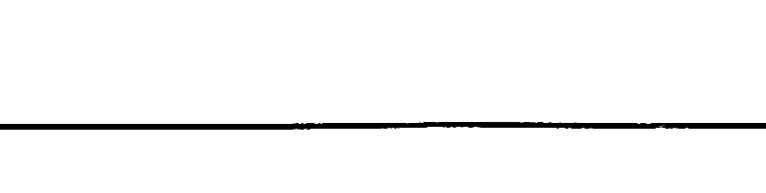
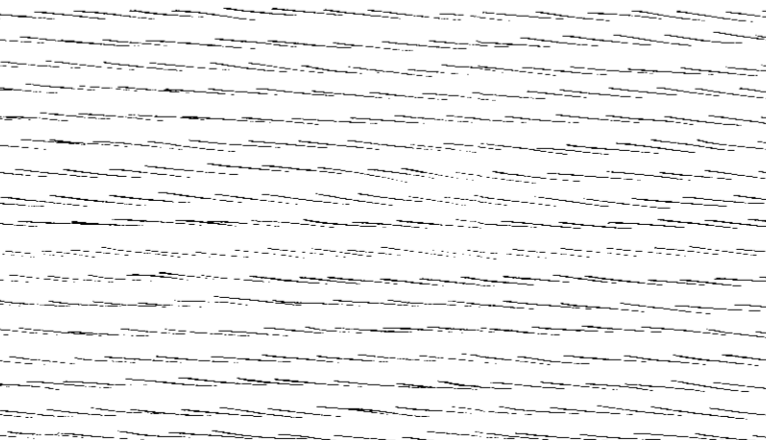
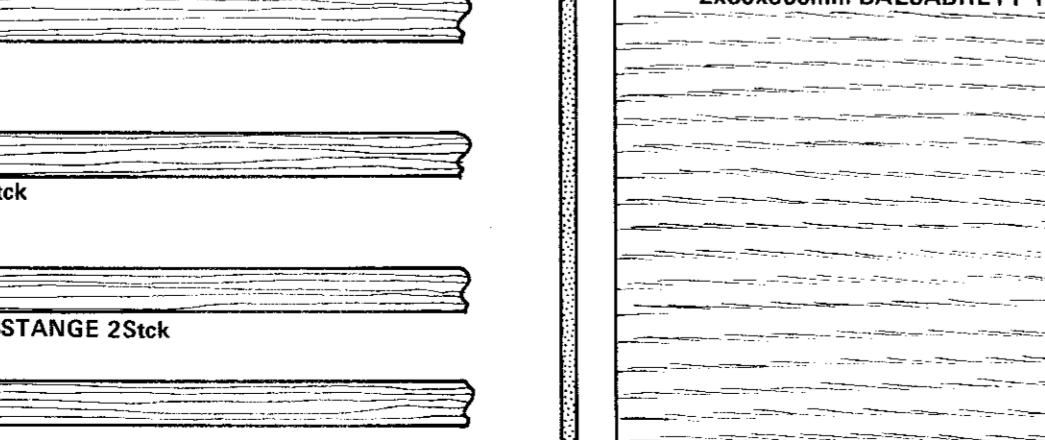
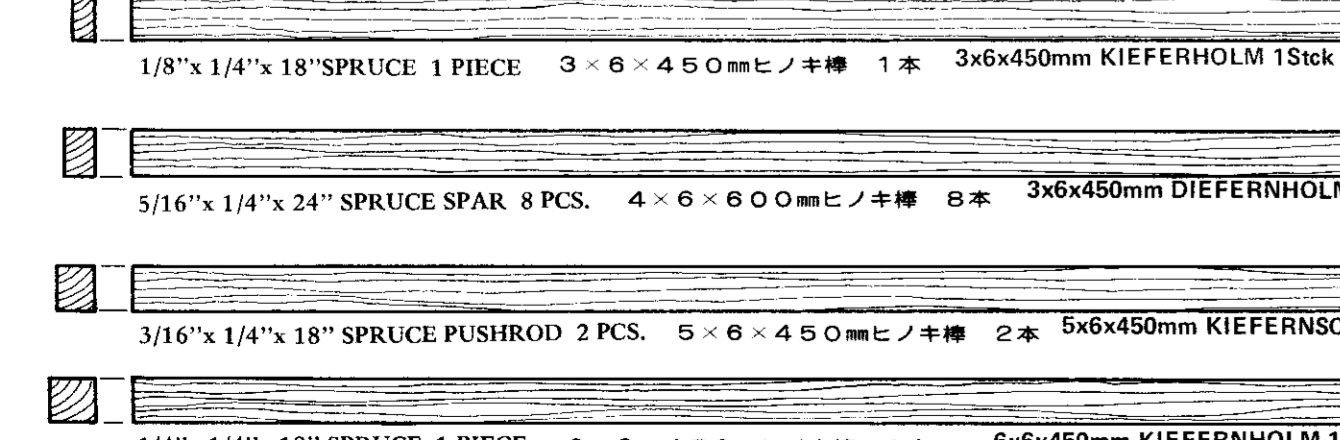
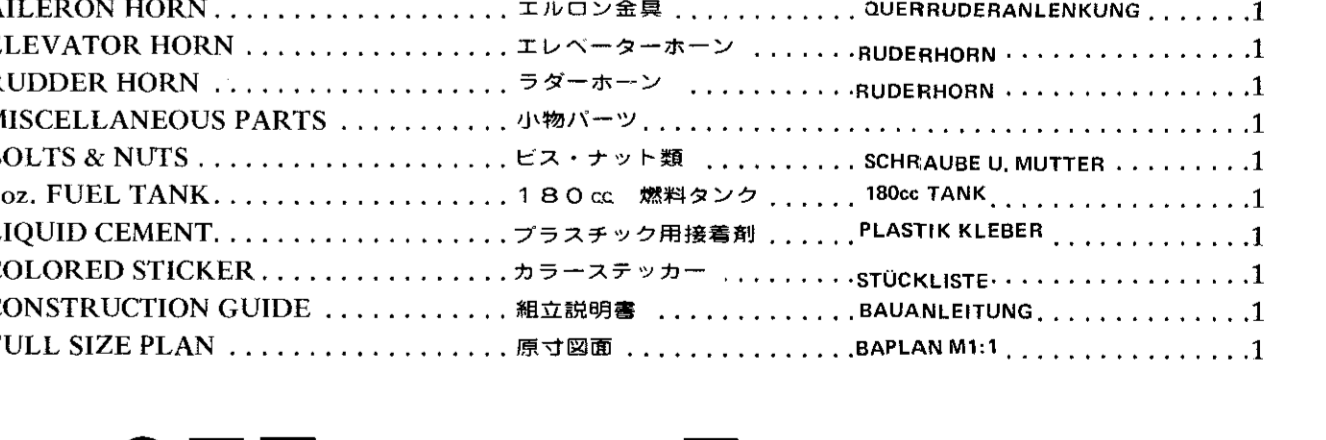
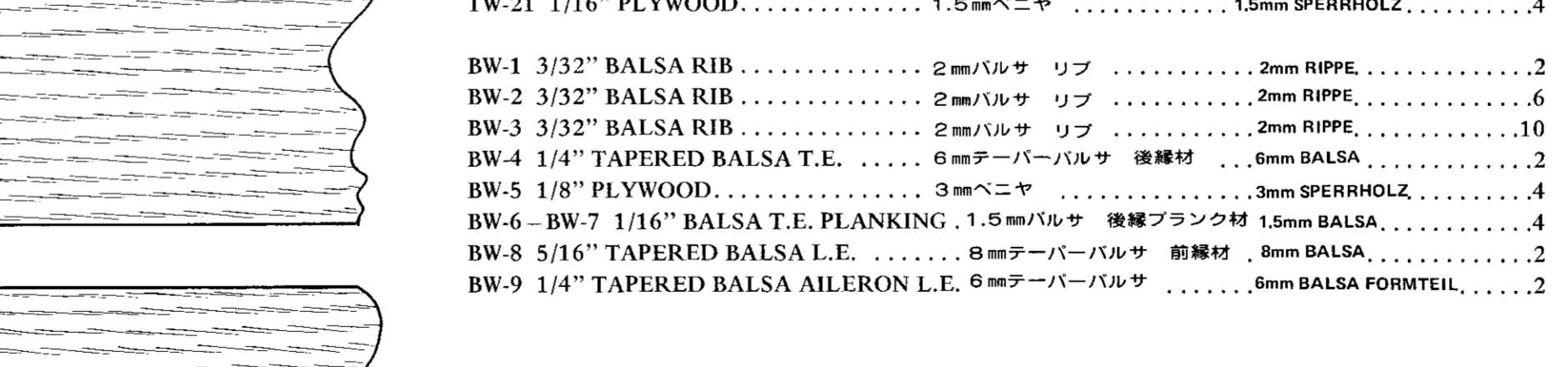
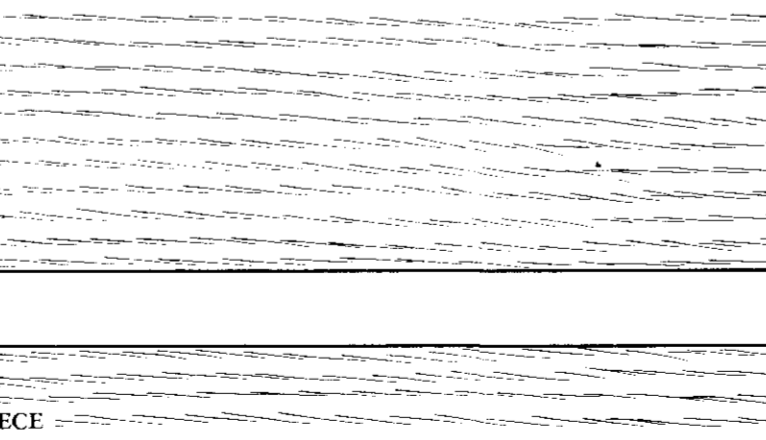
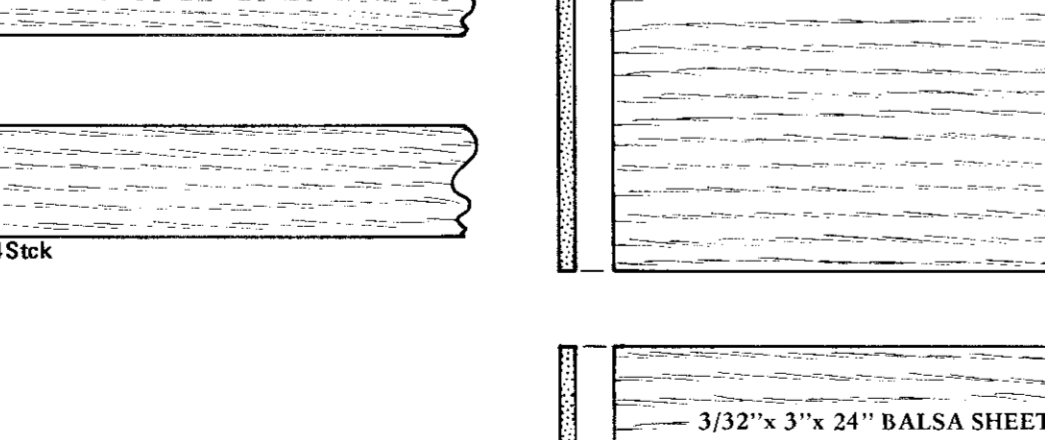
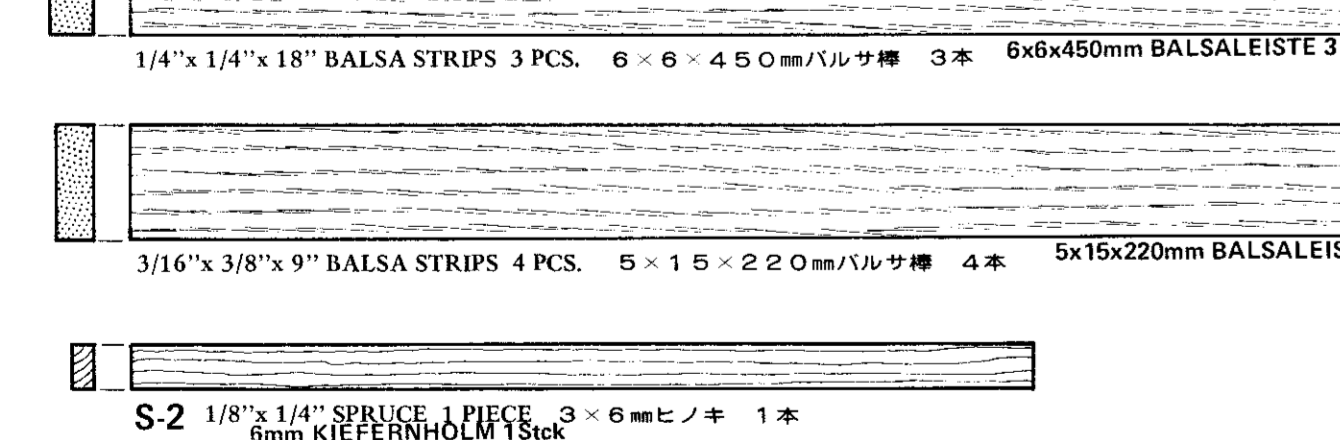
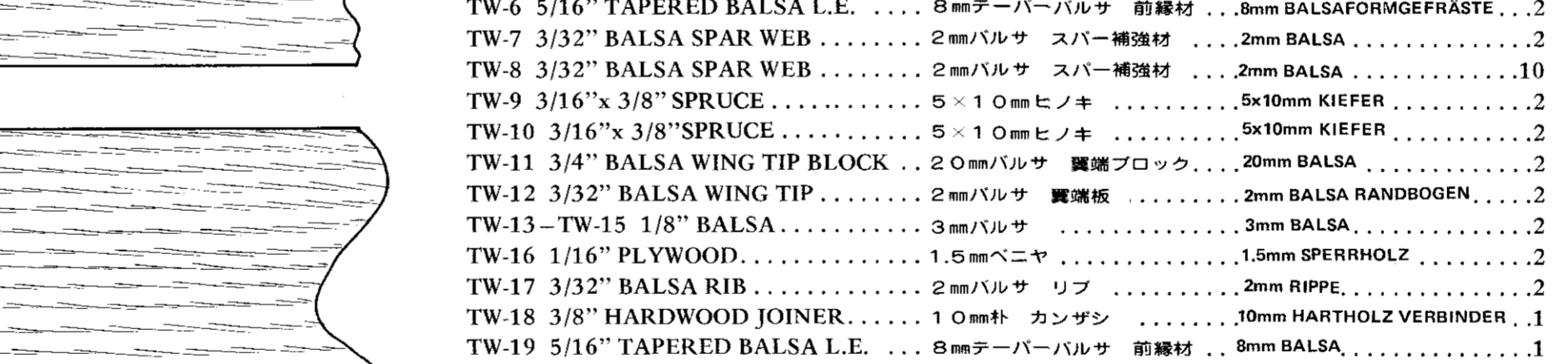
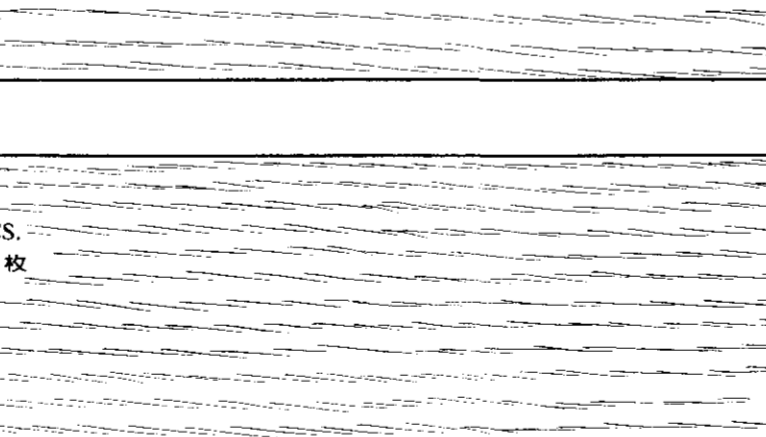
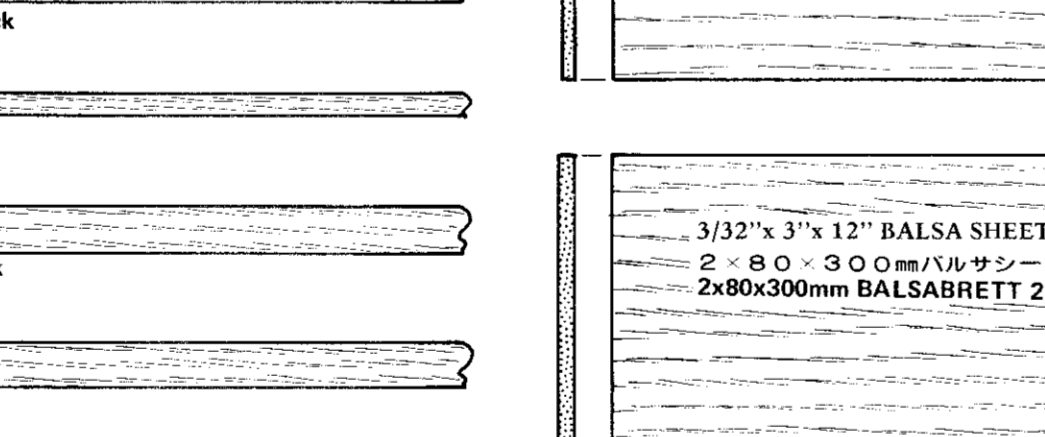
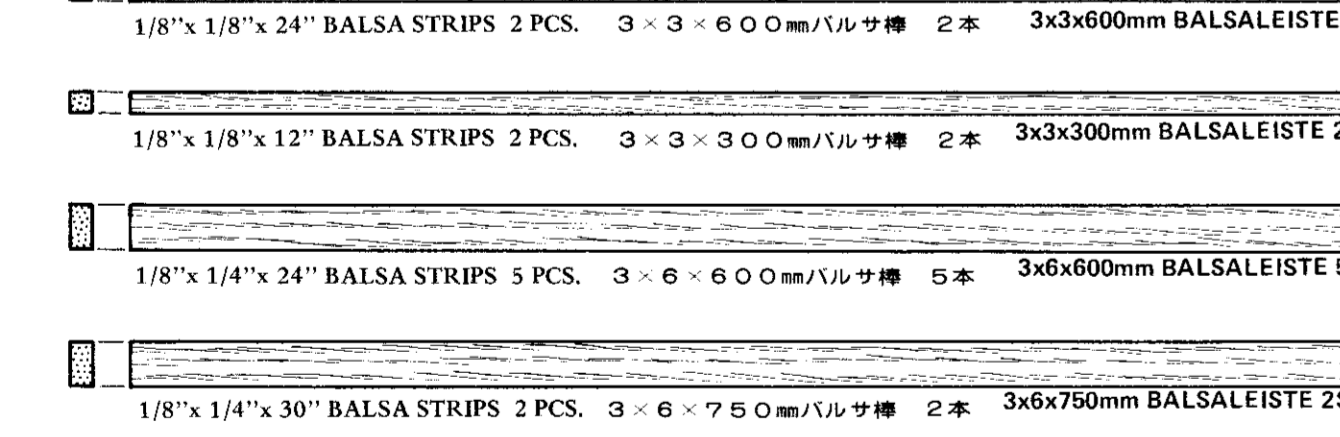
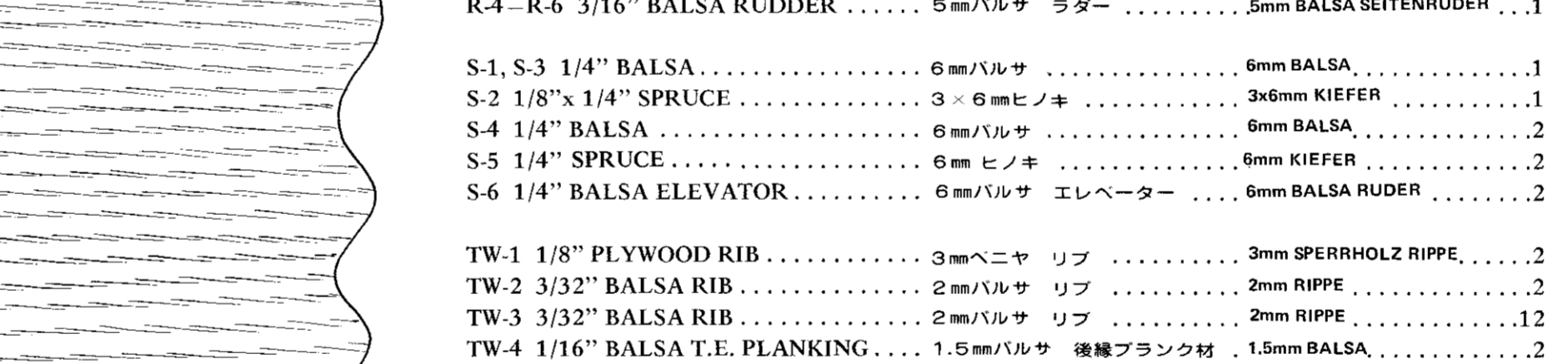
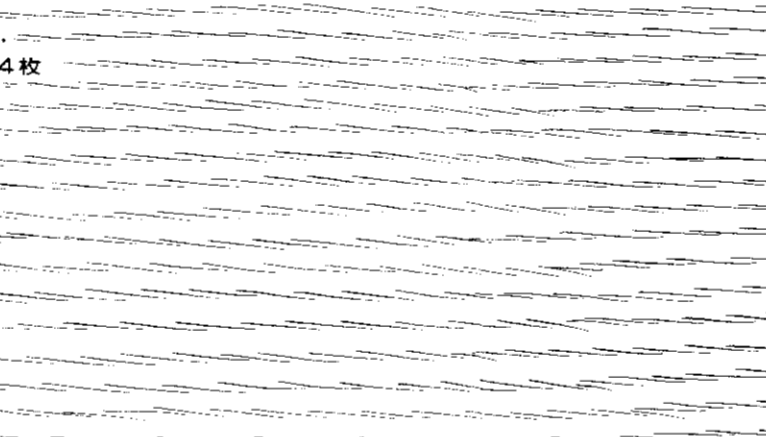
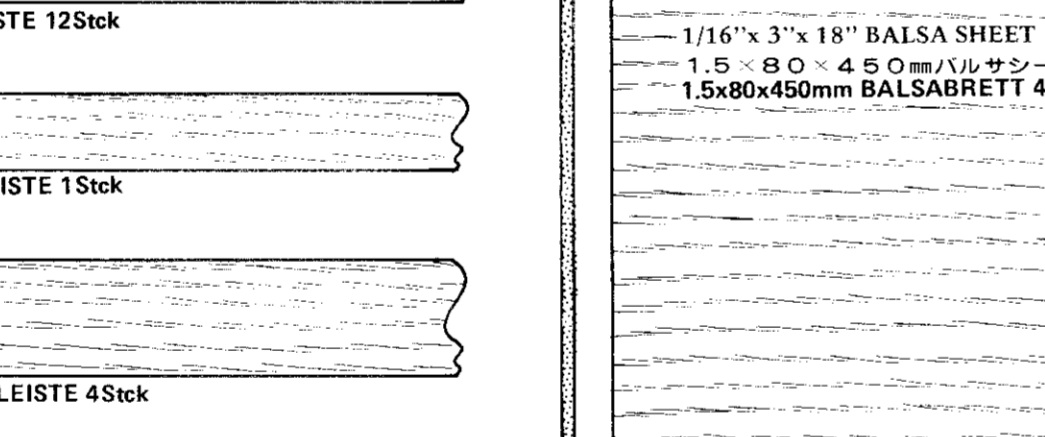
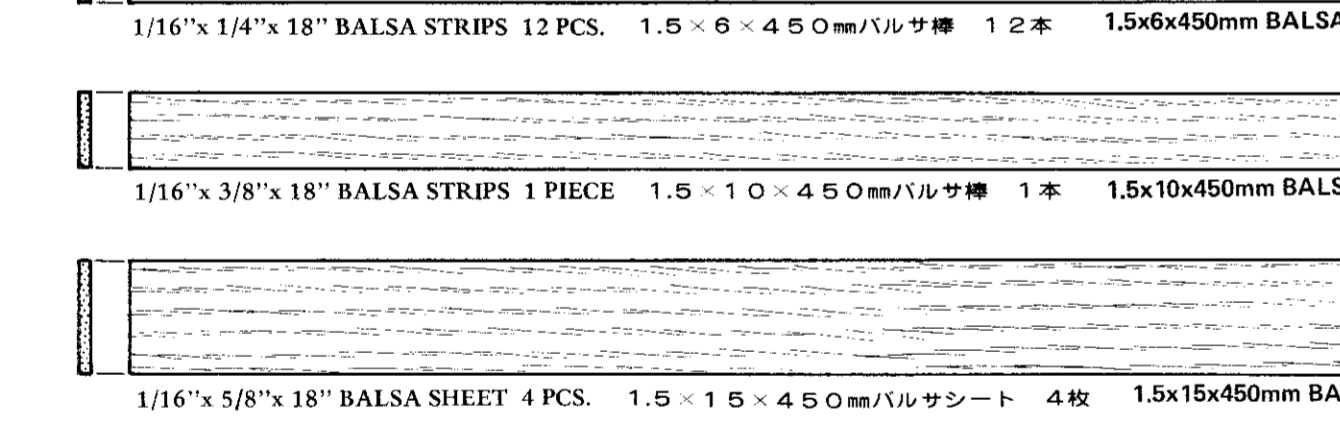
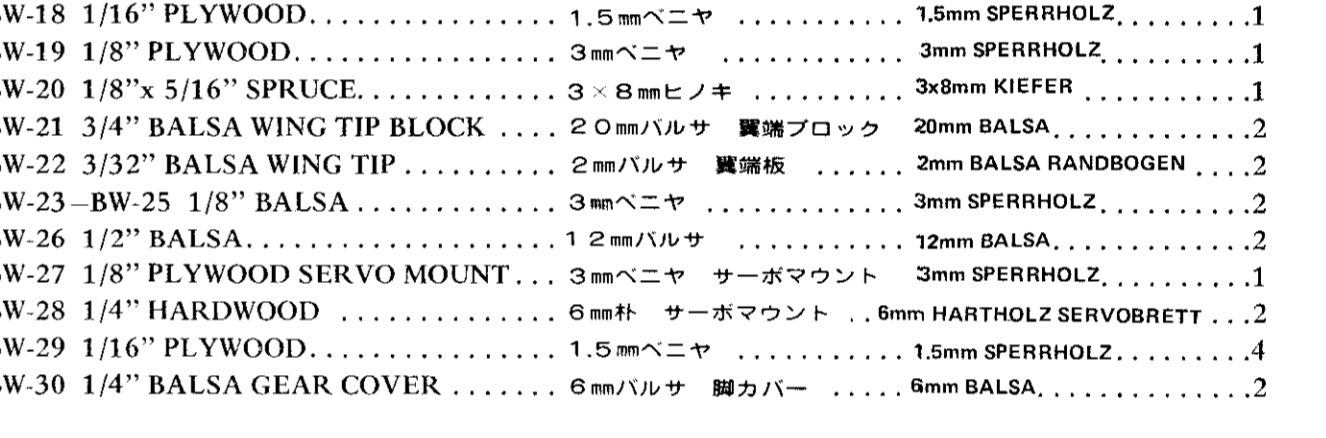
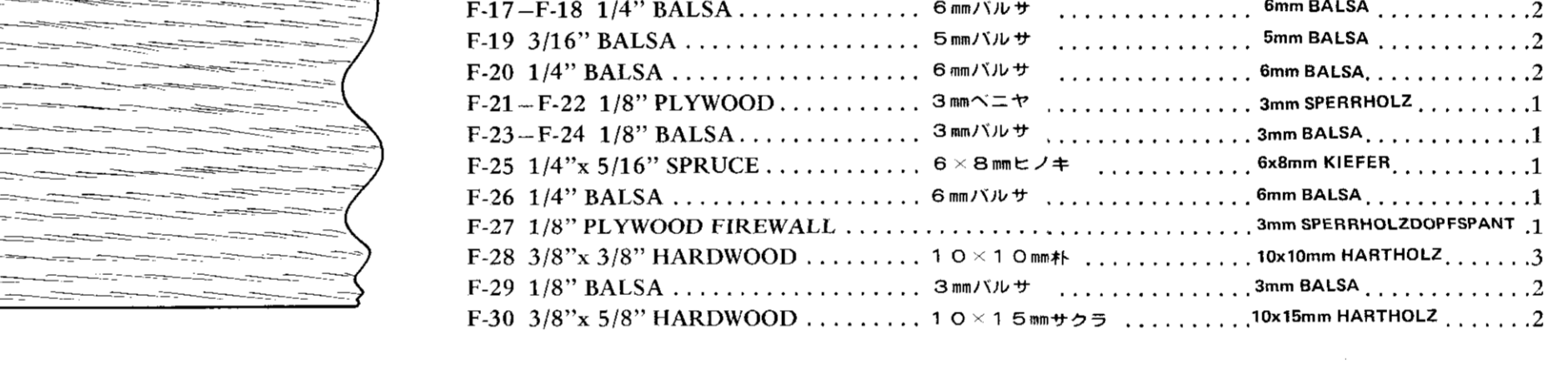
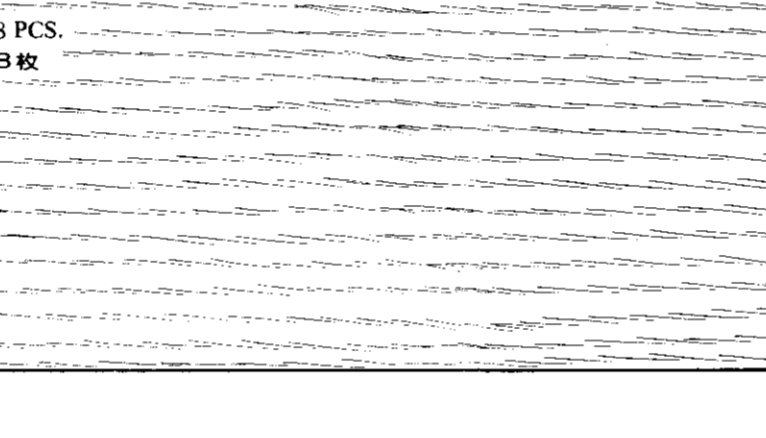
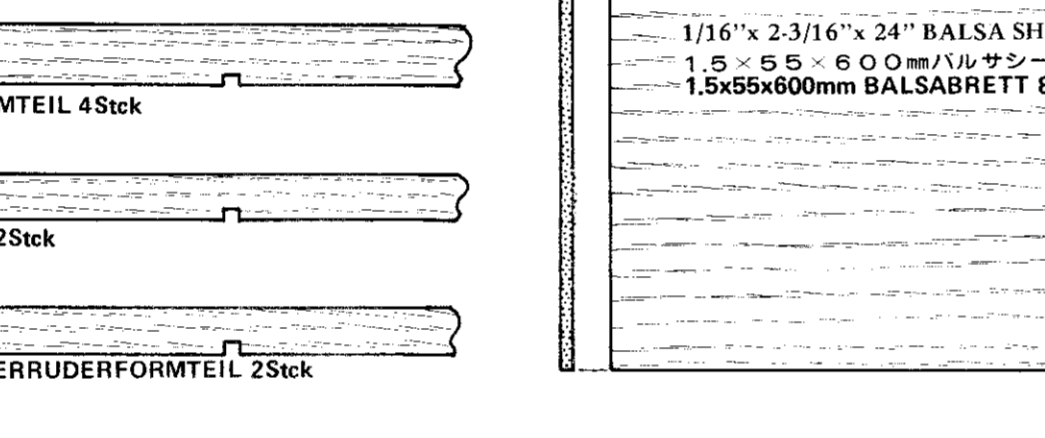
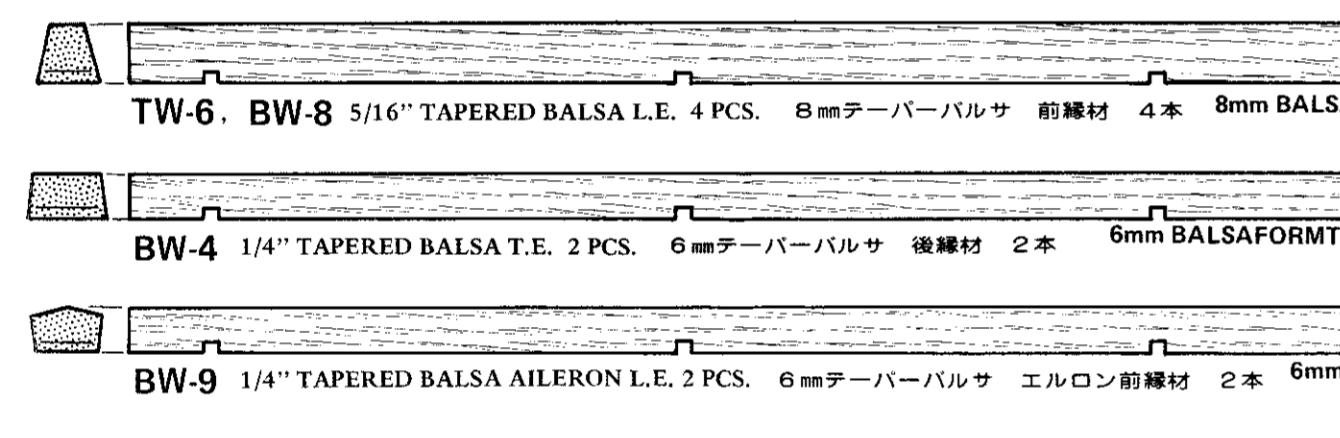
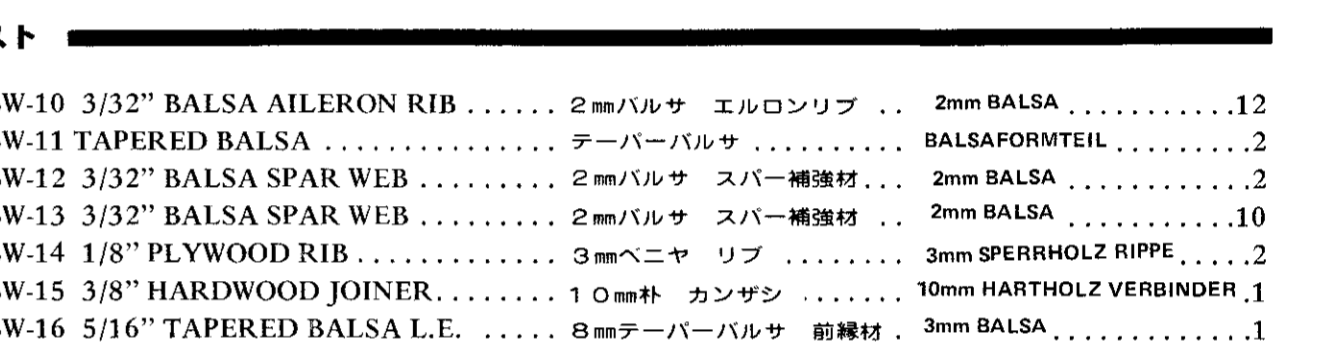
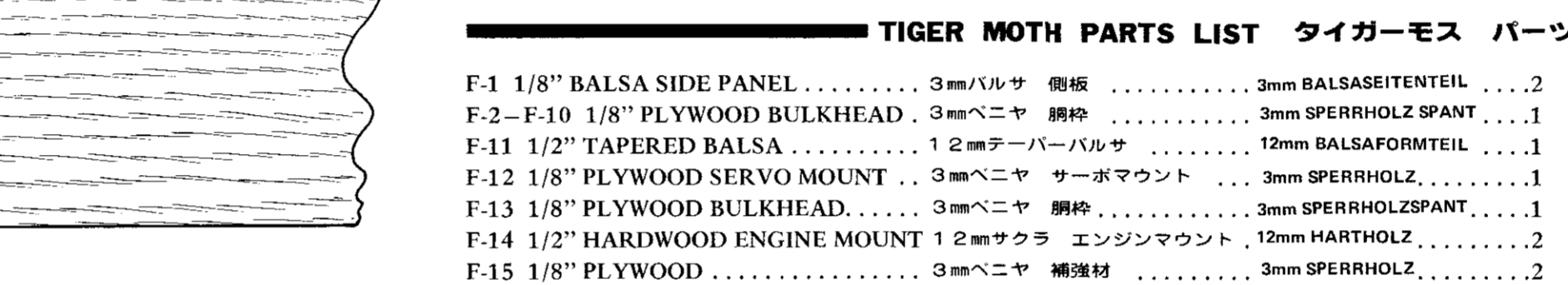
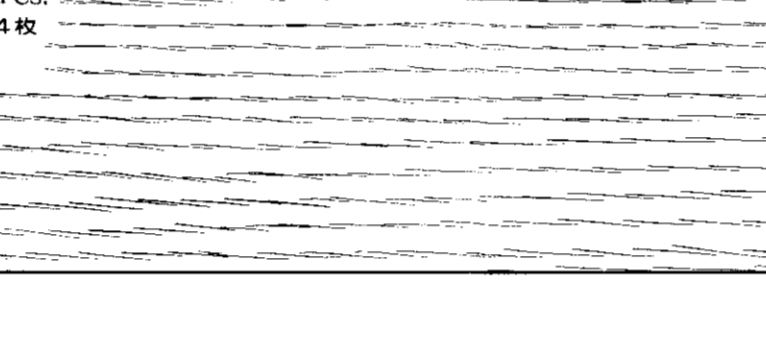
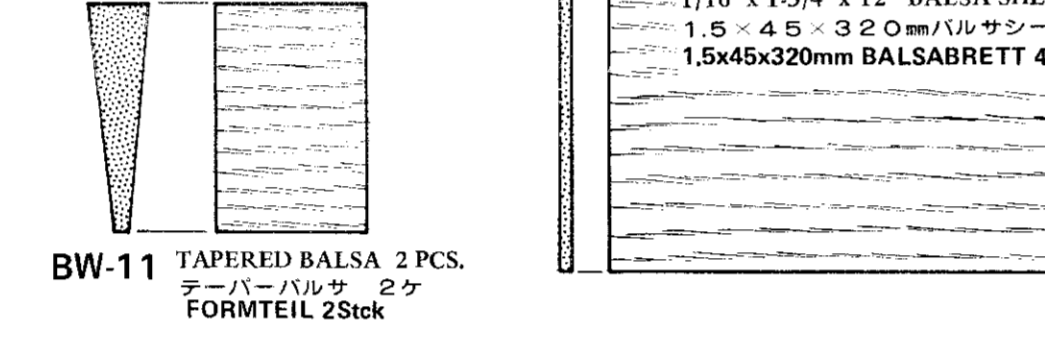
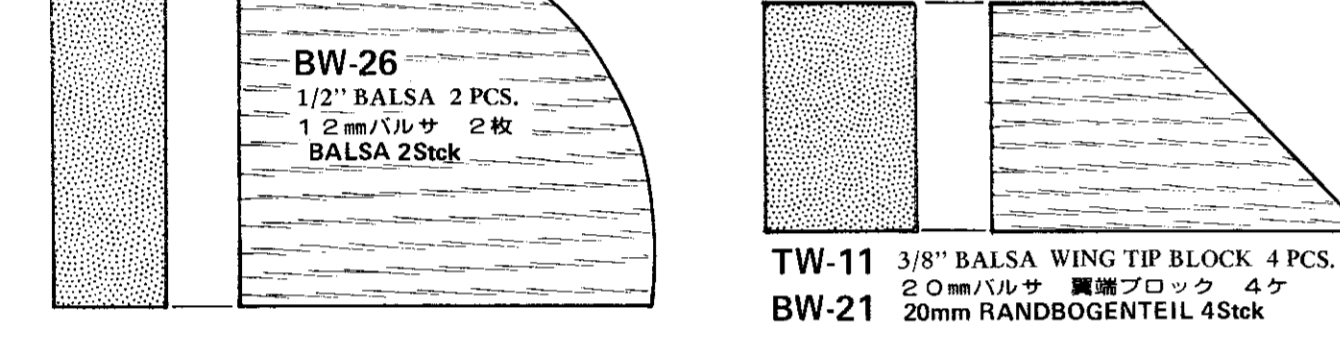
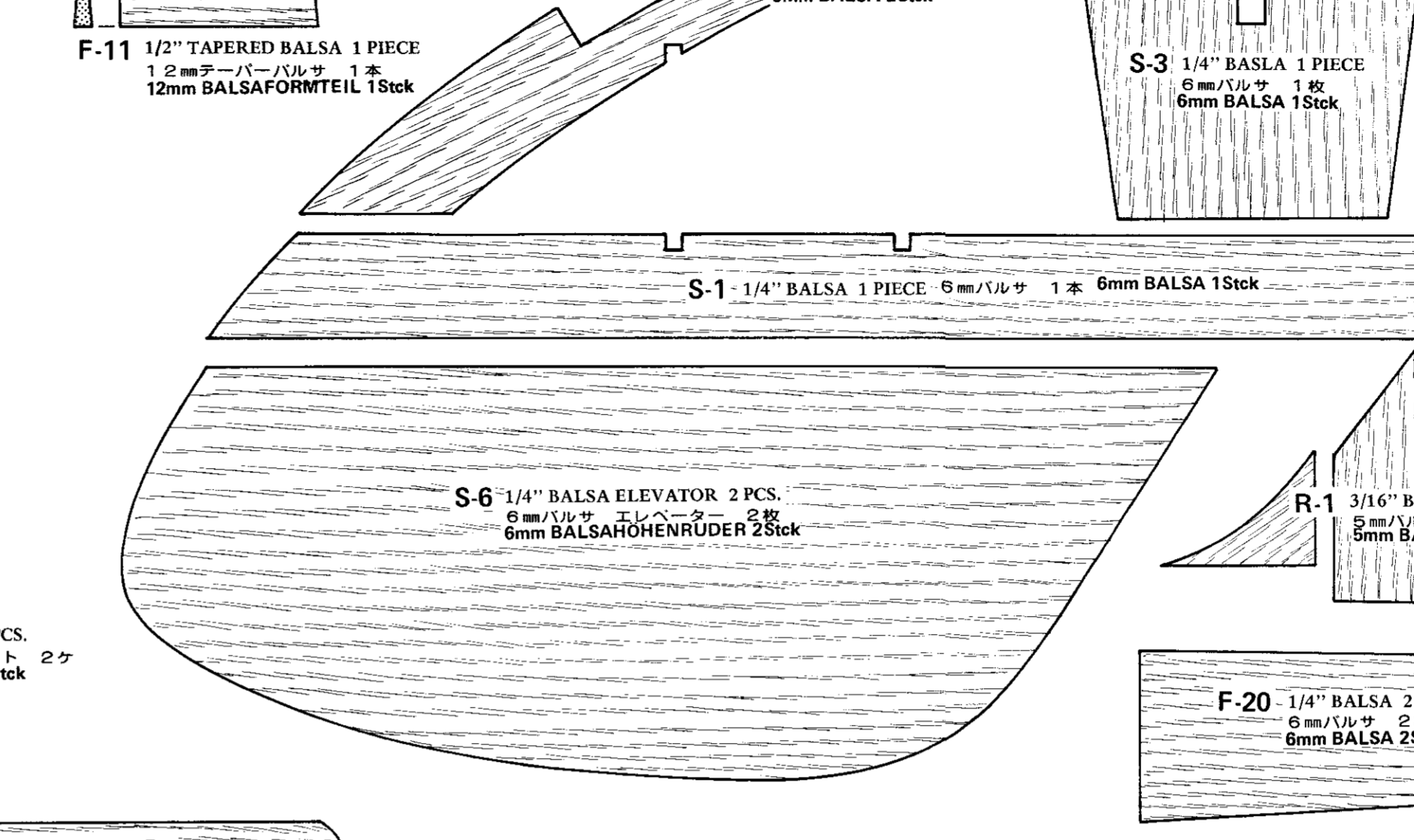
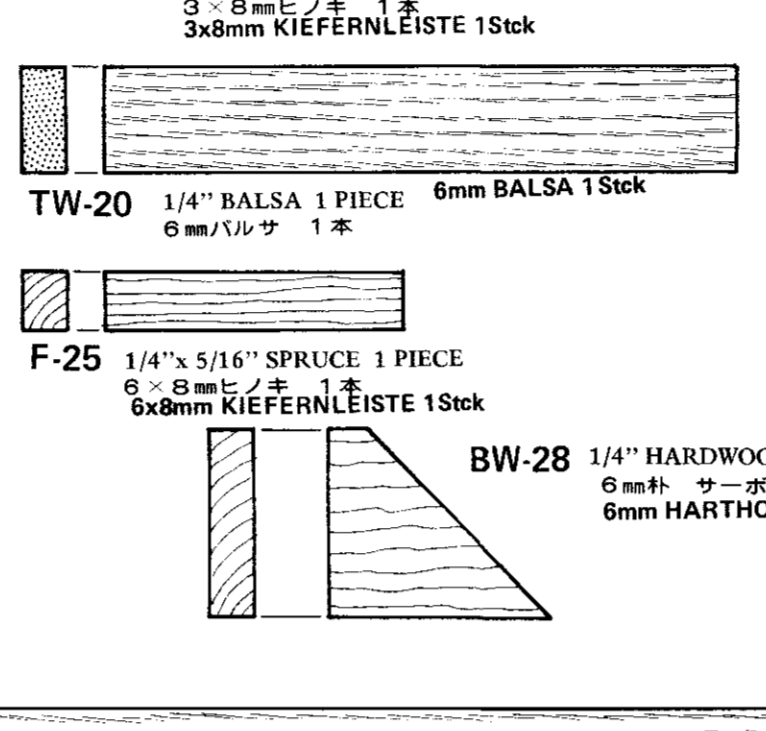
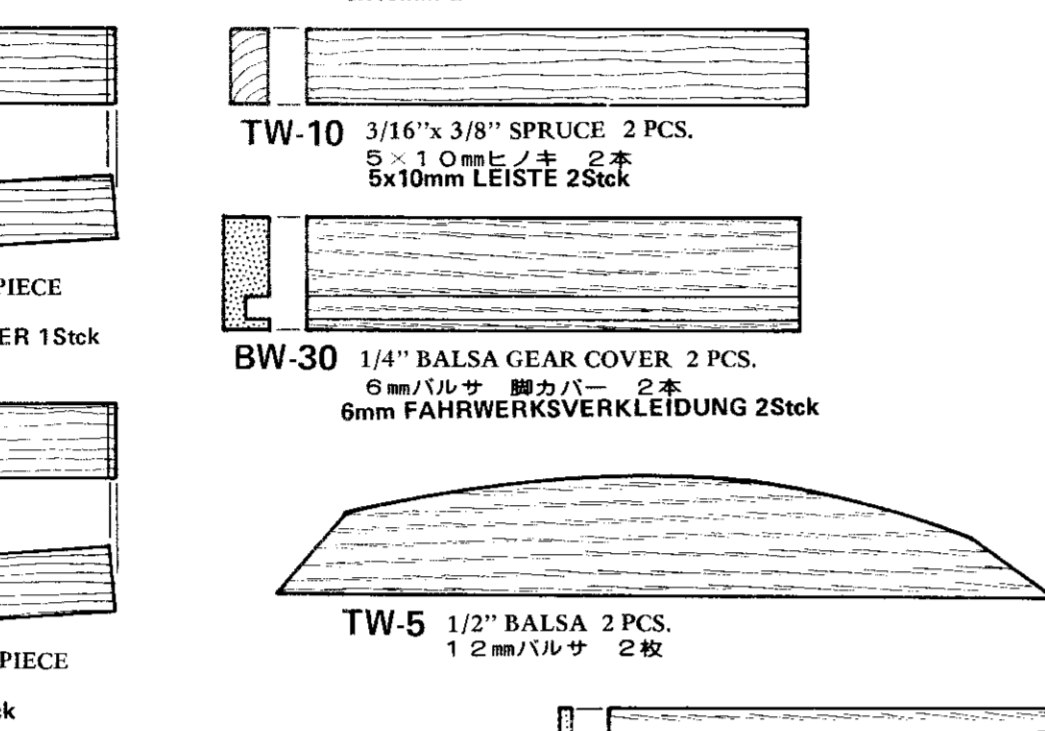
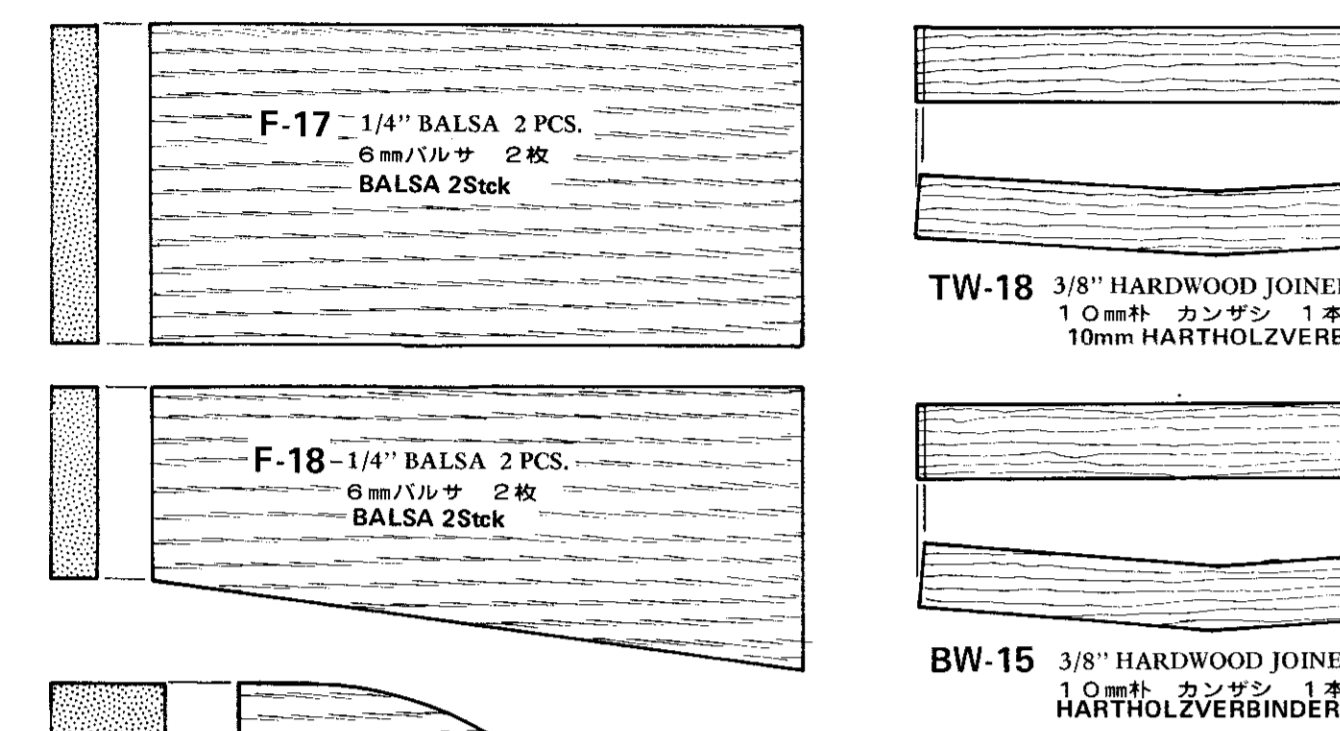
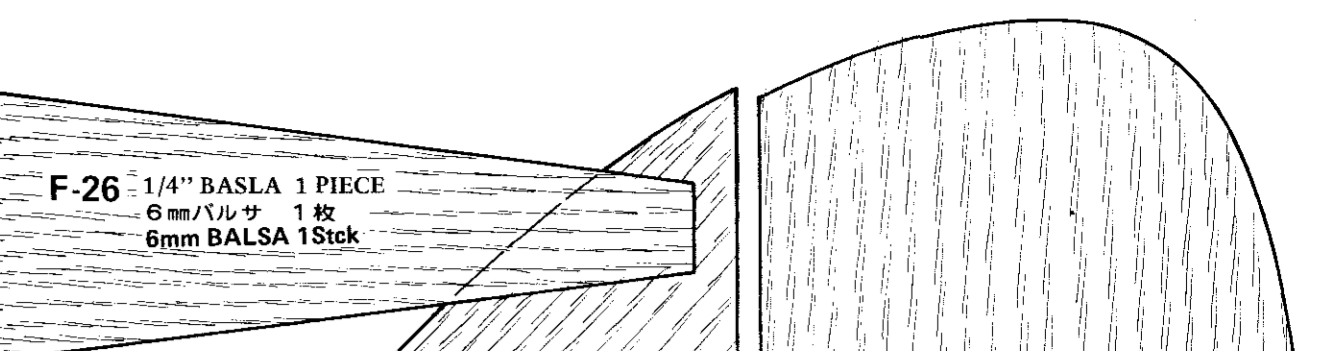
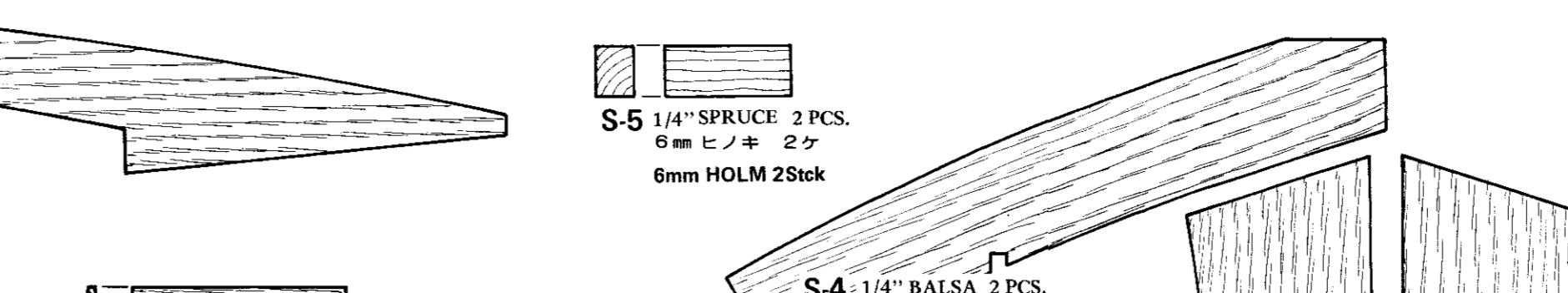
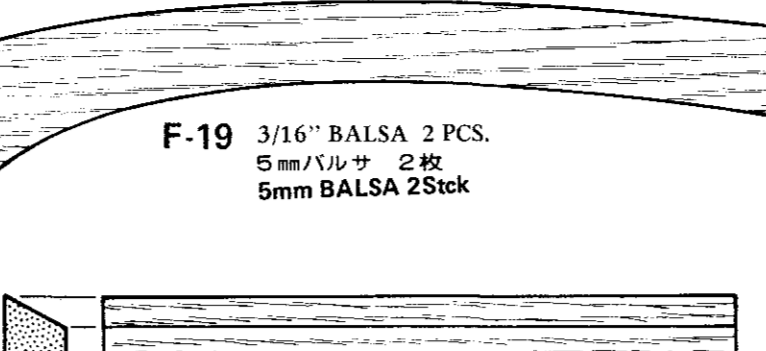
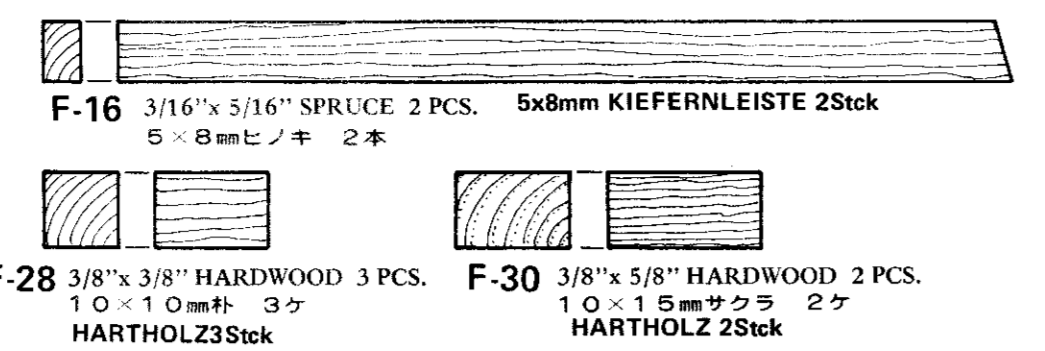
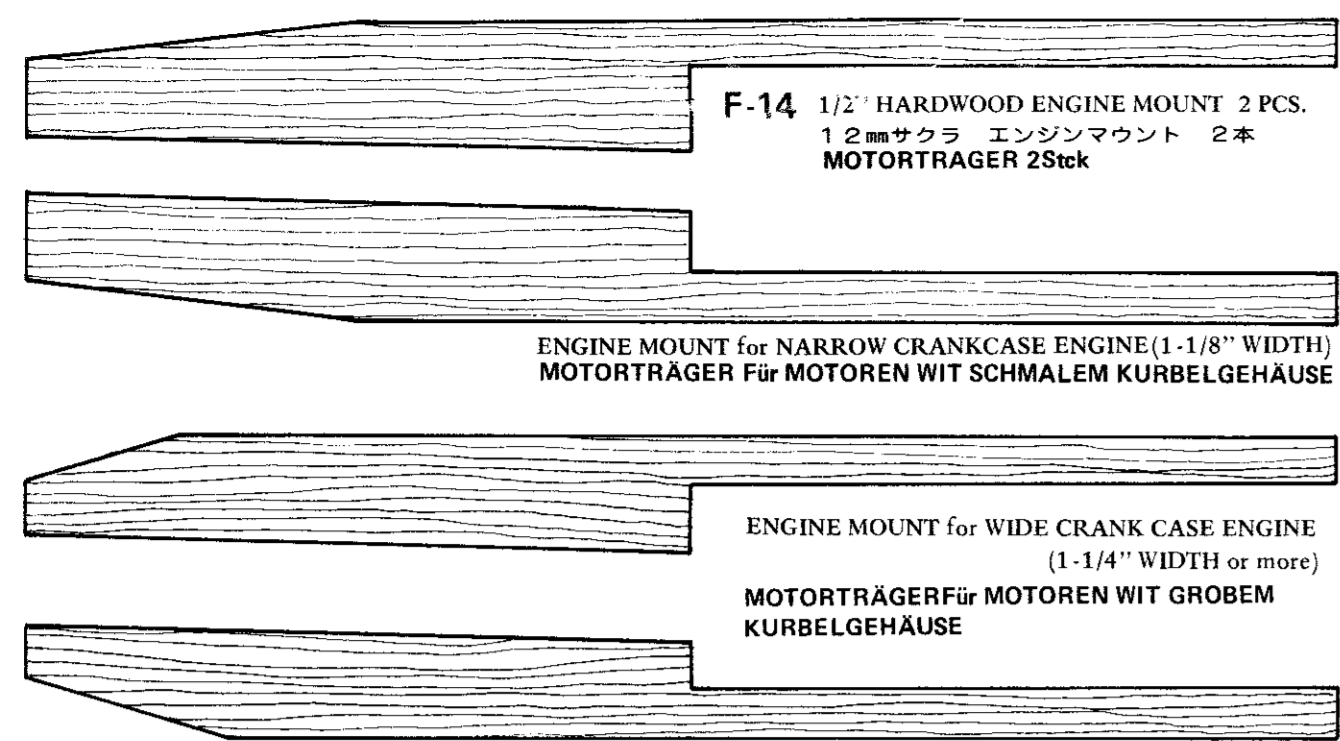

TIGER MOTH PARTS LIST		タイガーマス パーツリスト	
F-1	1/8" Balsa SIDE PANEL	3mmバルサ 側板	3mm BALSASEITENTEIL 2
F-2	1/8" PLYWOOD BULKHEAD	3mmベニヤ 胴板	3mm SPERRHOLZ SPANT 1
F-11	1/2" TAPERED Balsa	1.2mmテーパバールサ	12mm BalsaFORMTEIL 1
F-12	1/8" PLYWOOD SERVO MOUNT	3mmベニヤ サーボマウント	3mm SPERRHOLZ 1
F-13	1/8" PLYWOOD BULKHEAD	3mmベニヤ 胴板	3mm SPERRHOLZSPANT 1
F-14	1/2" HARDWOOD ENGINE MOUNT	1.2mmサクラ エンジンマウント	12mm HARTHOLZ 2
F-15	1/8" PLYWOOD	3mmベニヤ 補強材	3mm SPERRHOLZ 2
F-16	3/16" x 5/16" SPRUCE	5 x 8mmヒノキ	5x8mm KIEFER 2
F-17	1/8" x 5/16" SPRUCE	3 x 8mmヒノキ	3x8mm KIEFERNLEISTE 1
F-18	1/4" Balsa	6mmバルサ	6mm Balsa 2
F-19	3/16" Balsa	6mmバルサ	5mm Balsa 2
F-20	1/4" Balsa	6mmバルサ	6mm Balsa 2
F-21	1/8" x 5/16" SPRUCE	3 x 8mmヒノキ	3x8mm KIEFERNLEISTE 1
F-22	1/8" Balsa	3mmバルサ	3mm SPERRHOLZ 1
F-23	1/8" Balsa	3mmバルサ	3mm SPERRHOLZ 1
F-24	1/8" Balsa	3mmバルサ	3mm SPERRHOLZ 1
F-25	1/4" x 5/16" SPRUCE	6 x 8mmヒノキ	6x8mm KIEFER 1
F-26	1/4" Balsa	6mmバルサ	6mm Balsa 1
F-27	1/8" PLYWOOD FIREWALL	3mmベニヤ	3mm SPERRHOLZDOFFSPANT 1
F-28	3/8" x 3/8" HARDWOOD	1.0 x 1.0mmト	10x10mm HARTHOLZ 3
F-29	1/8" Balsa	3mmバルサ	3mm Balsa 2
F-30	3/8" x 5/8" HARDWOOD	1.0 x 1.5mmサクラ	10x15mm HARTHOLZ 2
R-1	3/16" Balsa V. STABILIZER	5mmバルサ 縦横補強	5mm Balsa SEITENLEITWERK 1
R-4	3/16" Balsa RUDDER	5mmバルサ ラダー	5mm Balsa SEITENRUDDER 1
S-1	1/4" Balsa	6mmバルサ	6mm Balsa 1
S-2	1/8" x 1/4" SPRUCE	3 x 6mmヒノキ	3x6mm KIEFER 1
S-4	1/4" Balsa	6mmバルサ	6mm Balsa 1
S-5	1/4" SPRUCE	6mmヒノキ	6mm KIEFER 2
S-6	1/4" Balsa ELEVATOR	6mmバルサ エレベーター	6mm Balsa RUDDER 2
TW-1	1/8" PLYWOOD RIB	3mmベニヤ リブ	3mm SPERRHOLZ RIPPE 2
TW-2	3/32" Balsa RIB	2mmバルサ リブ	2mm RIPPE 2
TW-3	3/32" Balsa RIB	2mmバルサ リブ	2mm RIPPE 12
TW-4	1/16" Balsa T.E. PLANKING	1.5mmバルサ 後縁フランク材	1.5mm Balsa 2
TW-5	1/2" Balsa	12mmバルサ	12mm Balsa 2
TW-6	5/16" TAPERED Balsa SPAR WEB	8mmテーパバールサ 前縁材	8mm BalsaFORMGEFRASTE 2
TW-7	3/32" Balsa SPAR WEB	2mmバルサ スパ-補強材	2mm Balsa 2
TW-8	3/32" Balsa SPAR WEB	2mmバルサ スパ-補強材	2mm Balsa 10
TW-9	3/16" x 3/8" SPRUCE	5 x 1.0mmヒノキ	5x10mm KIEFER 2
TW-10	3/16" x 3/8" SPRUCE	5 x 1.0mmヒノキ	5x10mm KIEFER 2
TW-11	3/4" Balsa WING TIP BLOCK	2.0mmバルサ 翼端ブロック	20mm Balsa 2
TW-12	3/32" Balsa WING TIP	2mmバルサ 翼端板	2mm Balsa RANDBOGEN 2
TW-13	1/16" Balsa	3mmバルサ	3mm Balsa 2
TW-16	1/16" Balsa	1.5mmベニヤ	1.5mm SPERRHOLZ 2
TW-17	3/32" Balsa RIB	2mmバルサ リブ	2mm RIPPE 2
TW-18	3/8" HARDWOOD JOINER	1.0mmト カンザシ	10mm HARTHOLZ VERBINDER 1
TW-19	5/16" TAPERED Balsa L.E.	8mmテーパバールサ 前縁材	8mm Balsa 1
TW-20	1/4" Balsa	6mmバルサ	6mm Balsa 1
TW-21	1/16" PLYWOOD	1.5mmベニヤ	1.5mm SPERRHOLZ 4
BW-1	3/32" Balsa RIB	2mmバルサ リブ	2mm RIPPE 2
BW-2	3/32" Balsa RIB	2mmバルサ リブ	2mm RIPPE 6
BW-3	3/32" Balsa RIB	2mmバルサ リブ	2mm RIPPE 10
BW-4	1/4" TAPERED Balsa T.E.	6mmテーパバールサ 後縁材	6mm Balsa 2
BW-5	1/8" PLYWOOD	3mmベニヤ	3mm SPERRHOLZ 4
BW-6	BW-7 1/16" Balsa T.E. PLANKING	1.5mmバルサ 後縁フランク材	1.5mm Balsa 4
BW-8	5/16" TAPERED Balsa L.E.	8mmテーパバールサ 前縁材	8mm Balsa 2
BW-9	1/4" TAPERED Balsa AILERON L.E.	6mmテーパバールサ	6mm Balsa FORMTEIL 2
BW-10	3/32" Balsa AILERON RIB	2mmバルサ エルロンリブ	2mm Balsa 12
BW-11	TAPERED Balsa	テーパバールサ	BalsaFORMTEIL 2
BW-12	3/32" Balsa SPAR WEB	2mmバルサ スパ-補強材	2mm Balsa 2
BW-13	3/32" Balsa SPAR WEB	2mmバルサ スパ-補強材	2mm Balsa 10
BW-14	1/8" PLYWOOD RIB	3mmベニヤ リブ	3mm SPERRHOLZ RIPPE 2
BW-15	3/8" HARDWOOD JOINER	1.0mmト カンザシ	10mm HARTHOLZ VERBINDER 1
BW-16	5/16" TAPERED Balsa L.E.	8mmテーパバールサ 前縁材	8mm Balsa 1
BW-17	5/16" HARDWOOD GEAR MOUNT	8mmト キヤーマウント	8mm HARTHOLZ 1
BW-18	1/16" PLYWOOD	1.5mmベニヤ	1.5mm SPERRHOLZ 1
BW-19	1/8" PLYWOOD	3mmベニヤ	3mm SPERRHOLZ 1
BW-20	1/8" x 5/16" SPRUCE	3 x 8mmヒノキ	3x8mm KIEFER 1
BW-21	3/8" Balsa WING TIP BLOCK	2.0mmバルサ 翼端ブロック	20mm Balsa 2
BW-22	3/32" Balsa WING TIP	2mmバルサ 翼端板	2mm Balsa RANDBOGEN 2
BW-23	1/8" Balsa	3mmベニヤ	3mm SPERRHOLZ 2
BW-26	1/2" Balsa	1.2mmバルサ	12mm Balsa 2
BW-27	1/8" PLYWOOD SERVO MOUNT	3mmベニヤ サーボマウント	3mm SPERRHOLZ 1
BW-28	1/4" HARDWOOD	6mmト キヤーマウント	6mm HARTHOLZ SERVOBRETT 2
BW-29	1/16" PLYWOOD	1.5mmベニヤ	1.5mm SPERRHOLZ 4
BW-30	1/4" Balsa GEAR COVER	6mmバルサ 覆カバー	6mm Balsa 2
1/16" x 2-3/16" x 24" Balsa SHEET	1.5 x 5.5 x 6.0 0mmバルサシート	1.5x55x600mm BALSABRETT	8
1/16" x 1-3/4" x 12" Balsa SHEET	1.5 x 4.5 x 3.2 0mmバルサシート	1.5x45x320mm BALSABRETT	4
1/16" x 3" x 18" Balsa SHEET	1.5 x 8.0 x 4.5 0mmバルサシート	1.5x80x450mm BALSABRETT	4
1/16" x 3" x 12" Balsa SHEET	1.5 x 8.0 x 4.5 0mmバルサシート	1.5x80x300mm BALSABRETT	4
3/32" x 3" x 24" Balsa SHEET	2 x 8.0 x 3.0 0mmバルサシート	2x80x300mm BALSABRETT	2
1/16" x 1/4" x 18" Balsa STRIPS	1.5 x 6.0 x 4.5 0mmバルサ条	1.5x60x4	

