

SEVENTY

a 70cm long fast electric racer designed by John Simpson

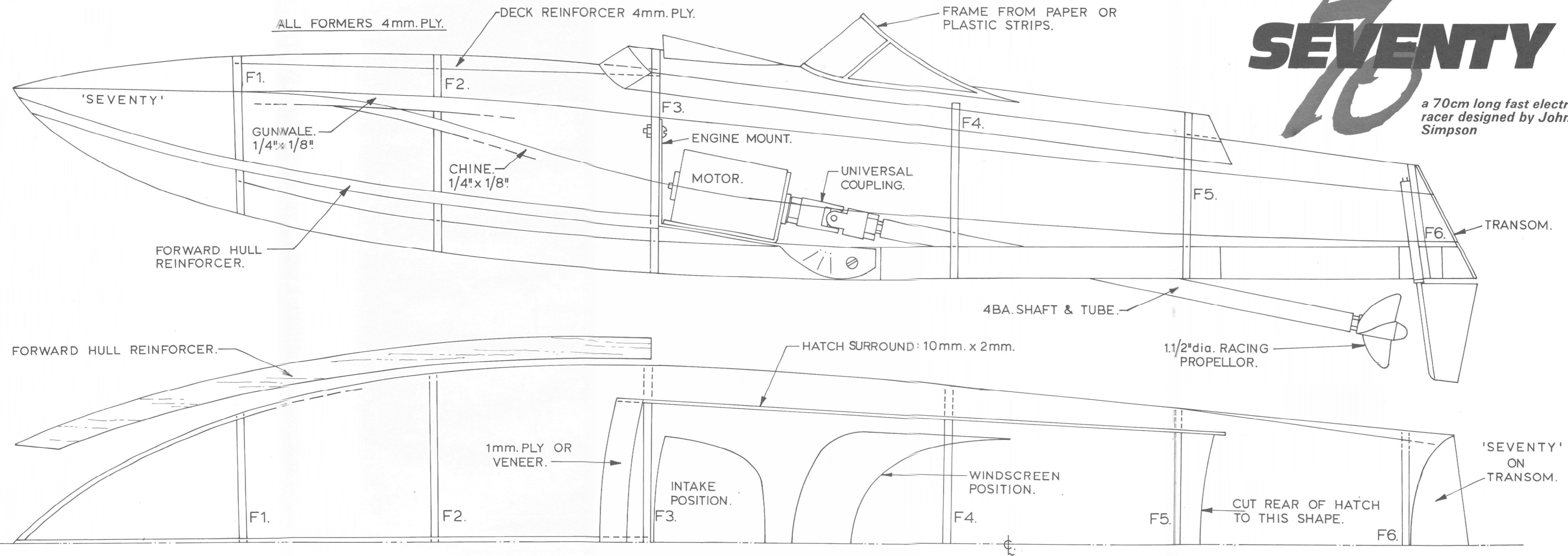

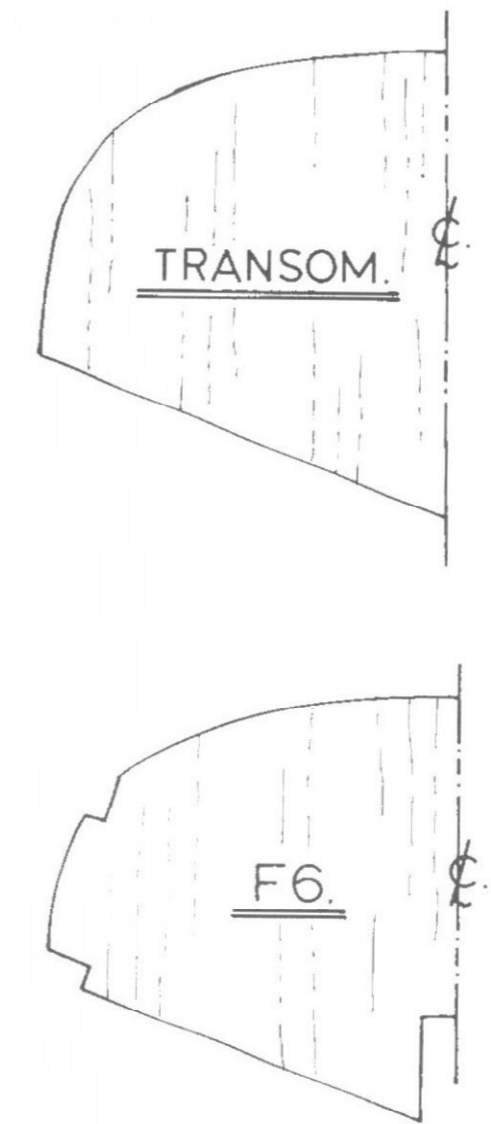
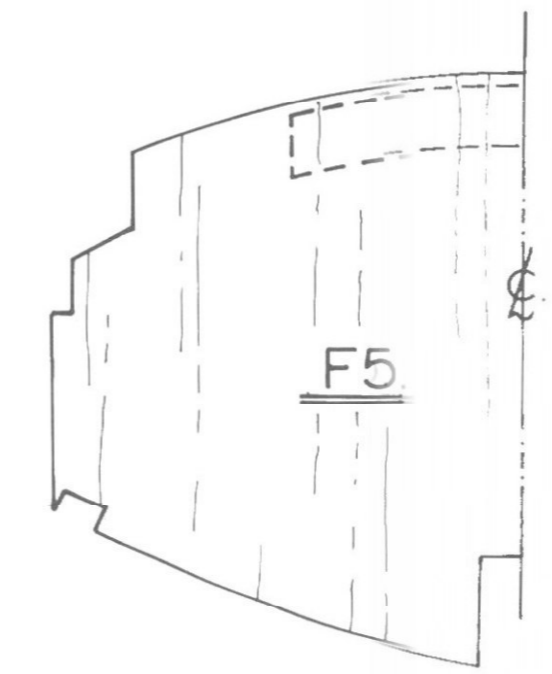
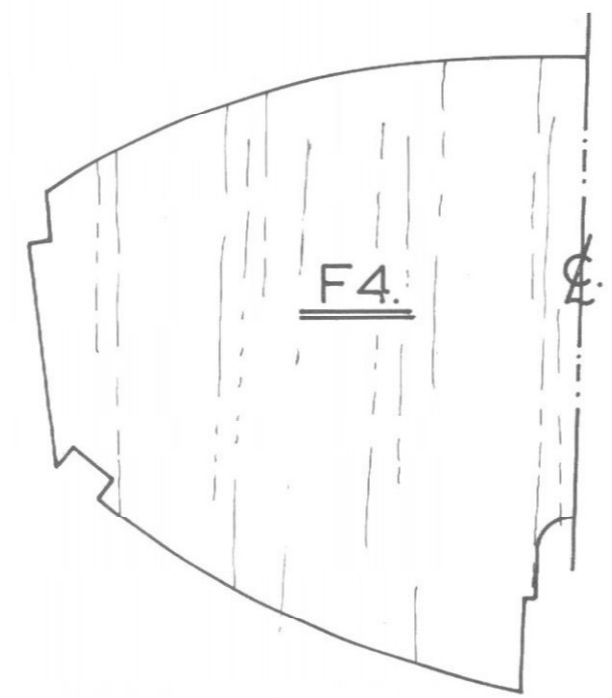
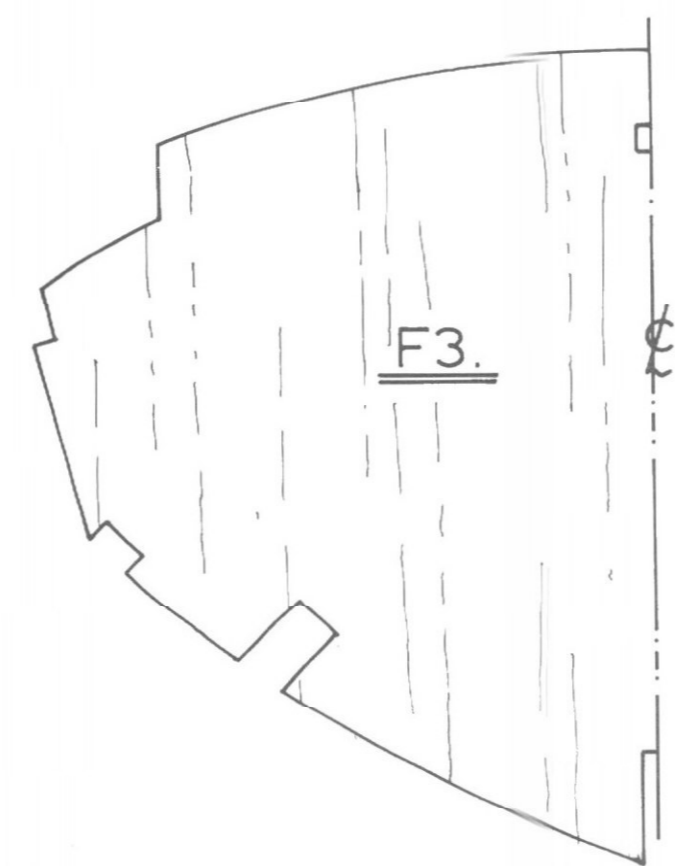
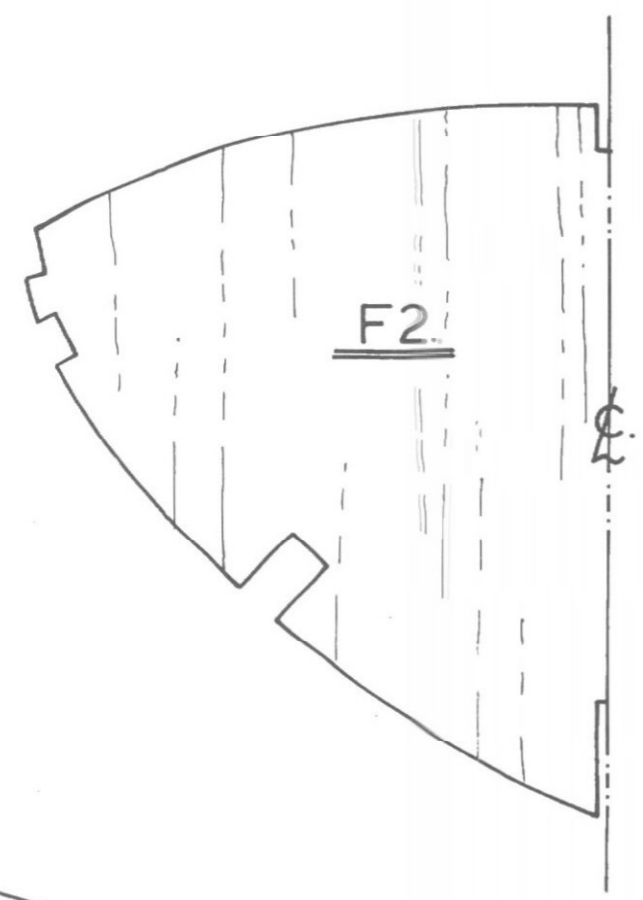
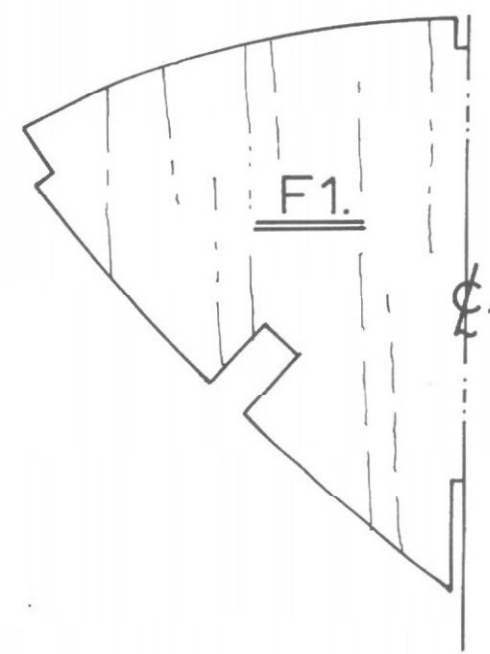
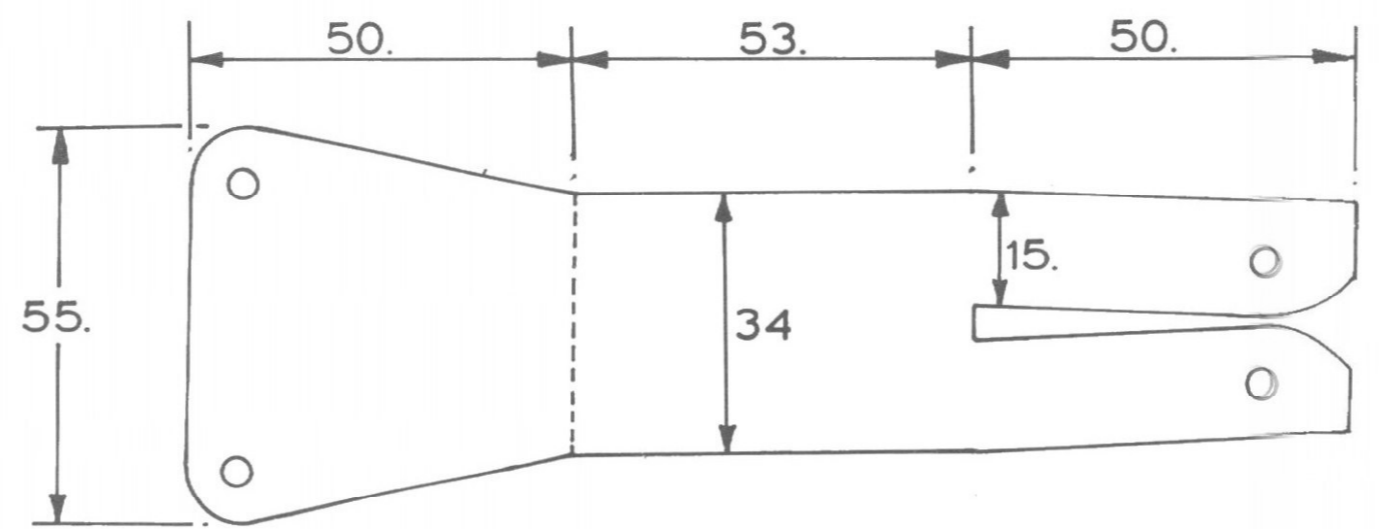
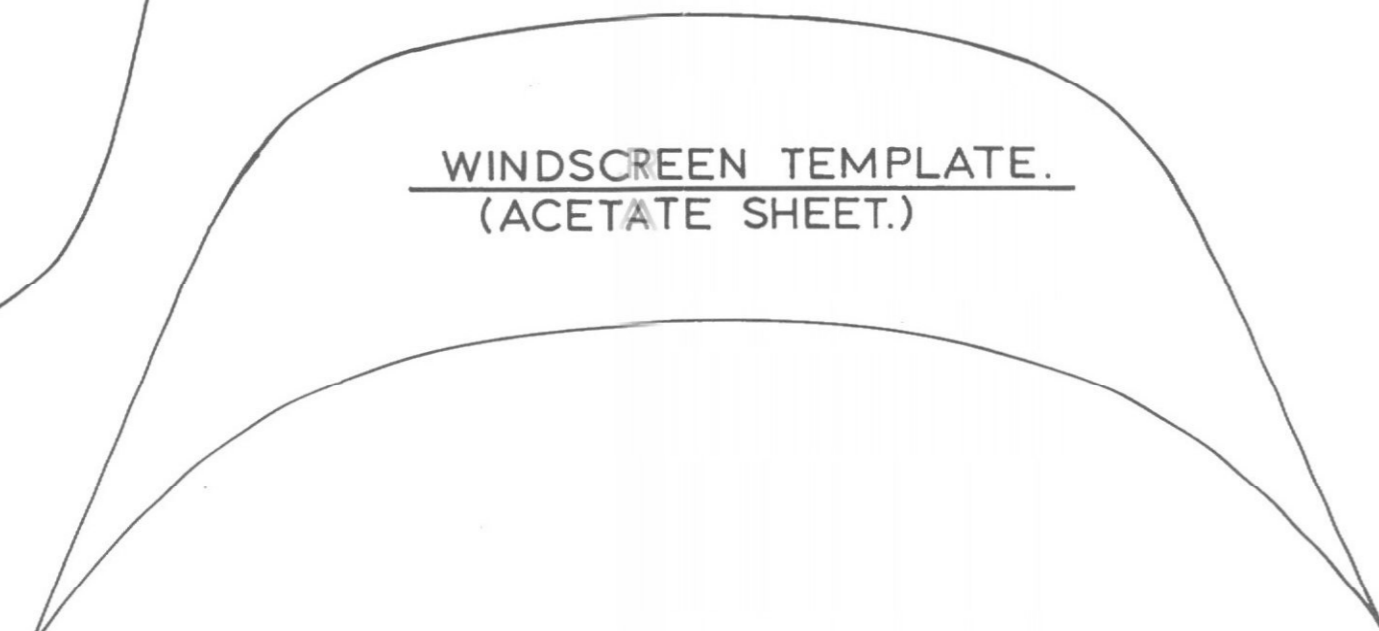
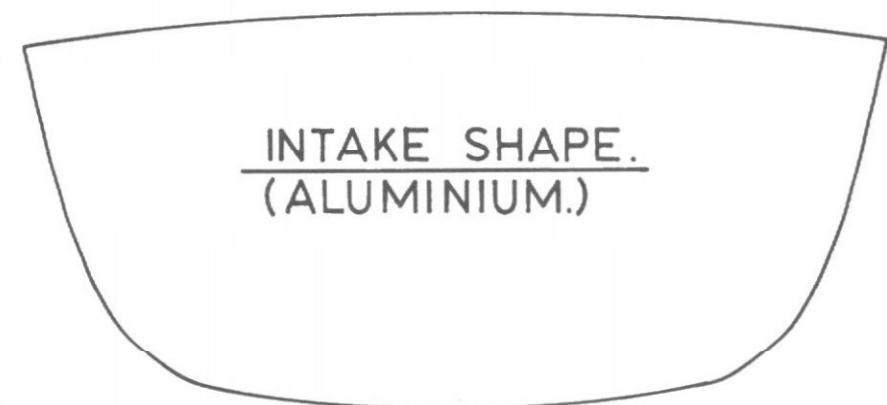

MOTOR MOUNT.
All sizes in mm.

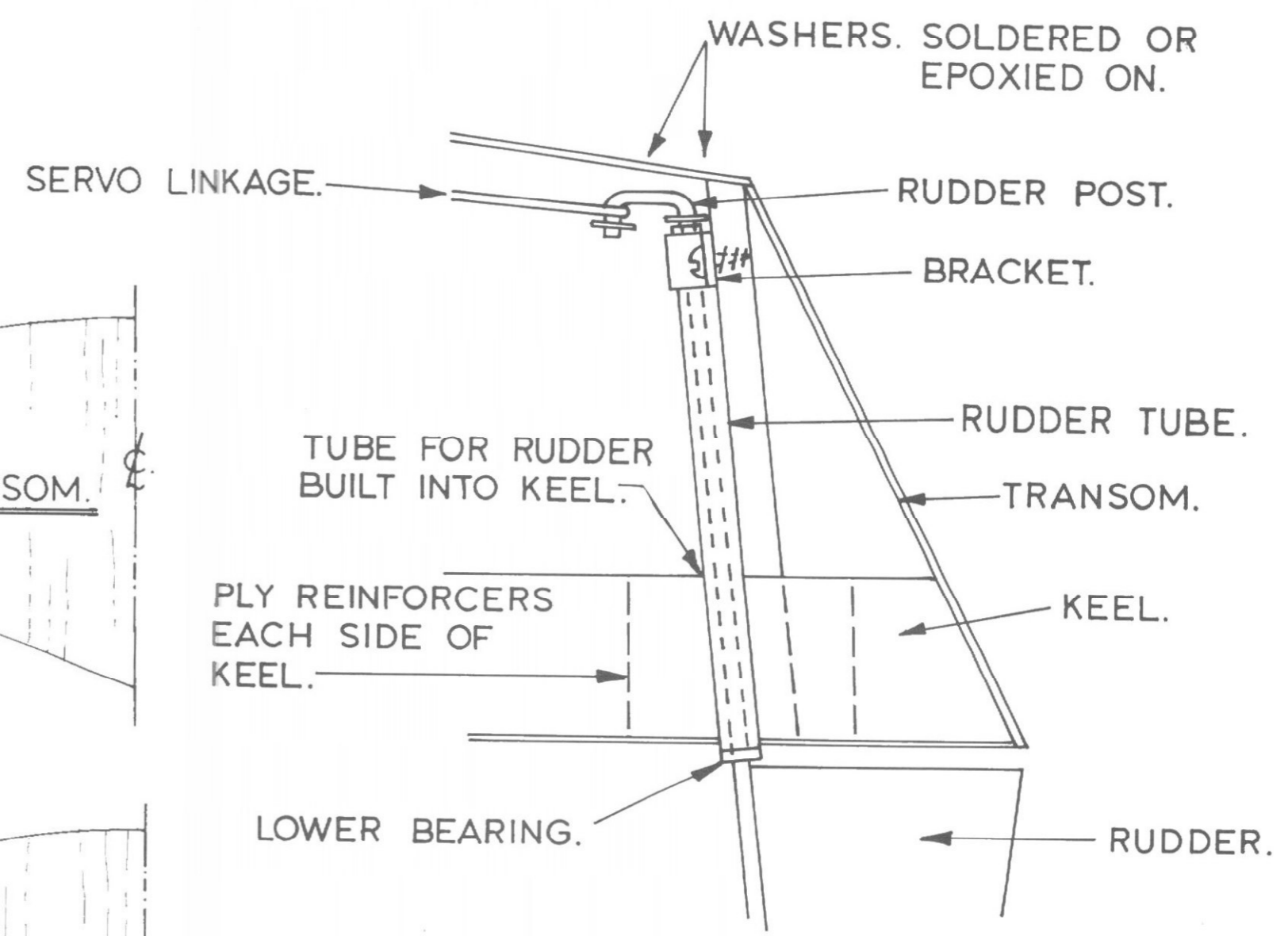
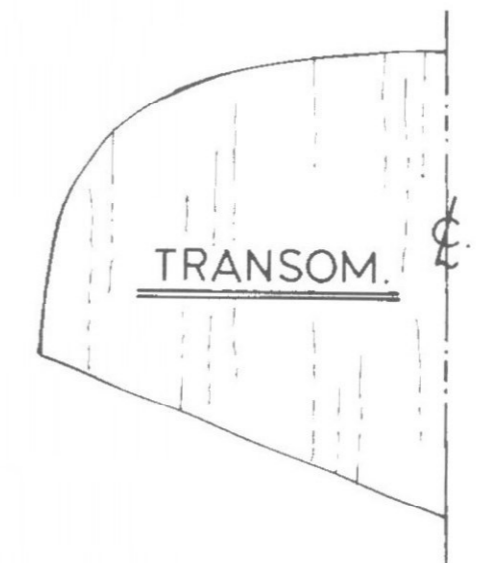
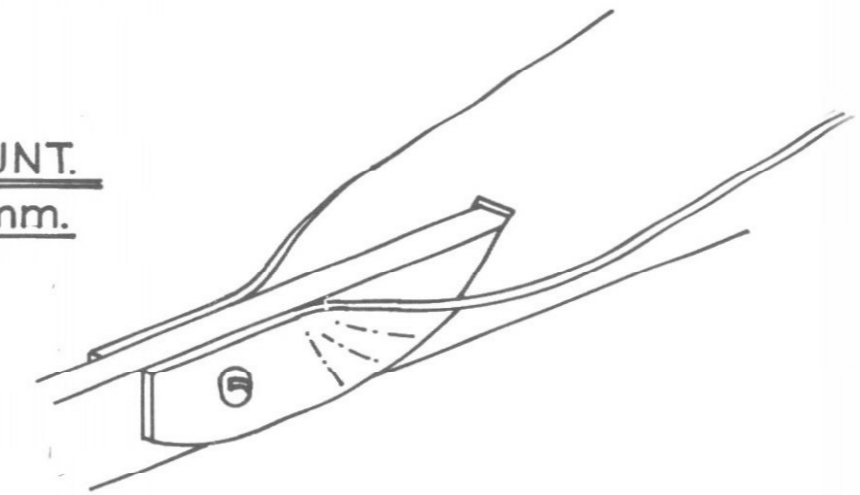

RUDDER ASSEMBLY & LINKAGE.

KEEL FROM 4mm. PLY.

ALL FORMERS FROM 4mm. PLY.

4mm. PLY REINFORCEMENT
EITHER SIDE OF KEEL.

