

# Mantis

Glynn Guest's Full-size plan  
for a Fast Electric  
Tunnel/Catamaran

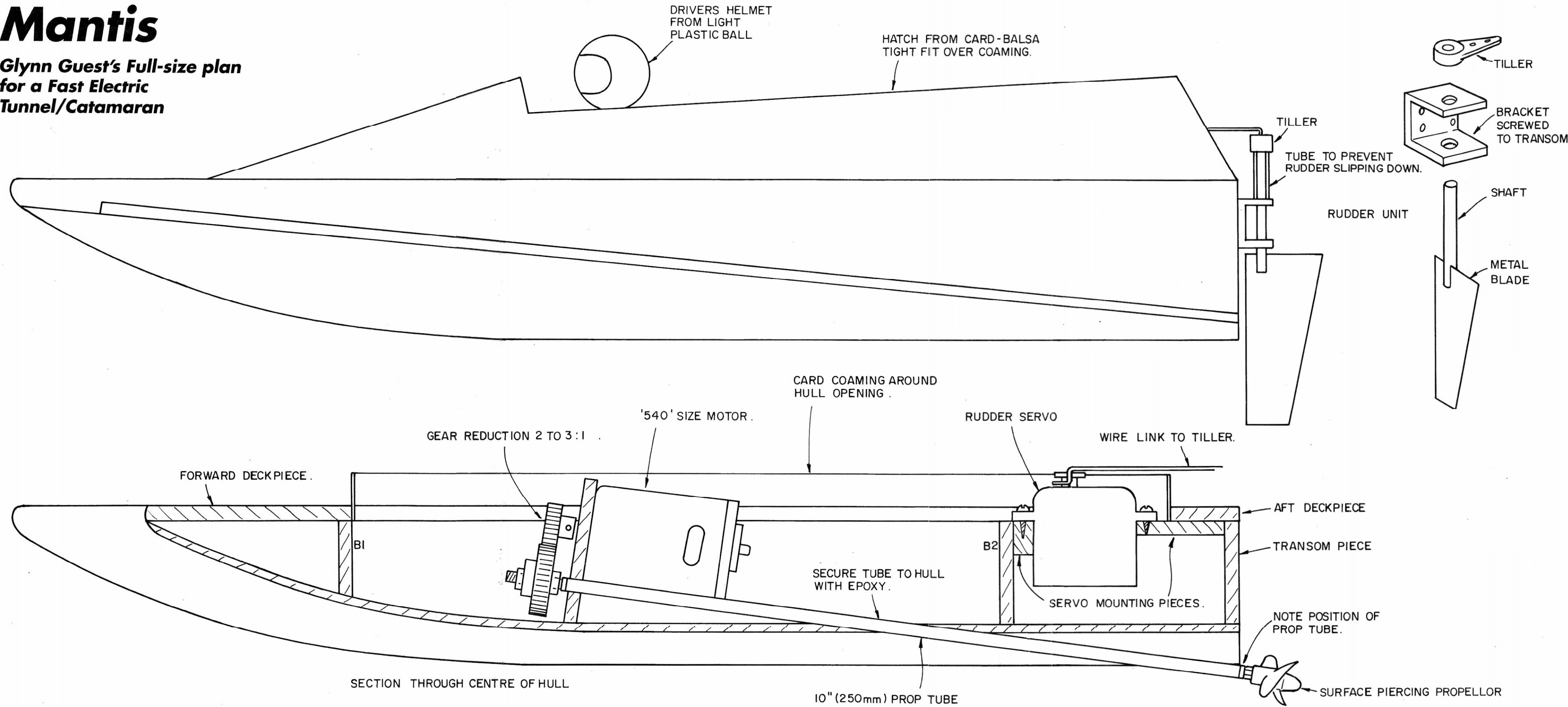

## HULL CONSTRUCTION

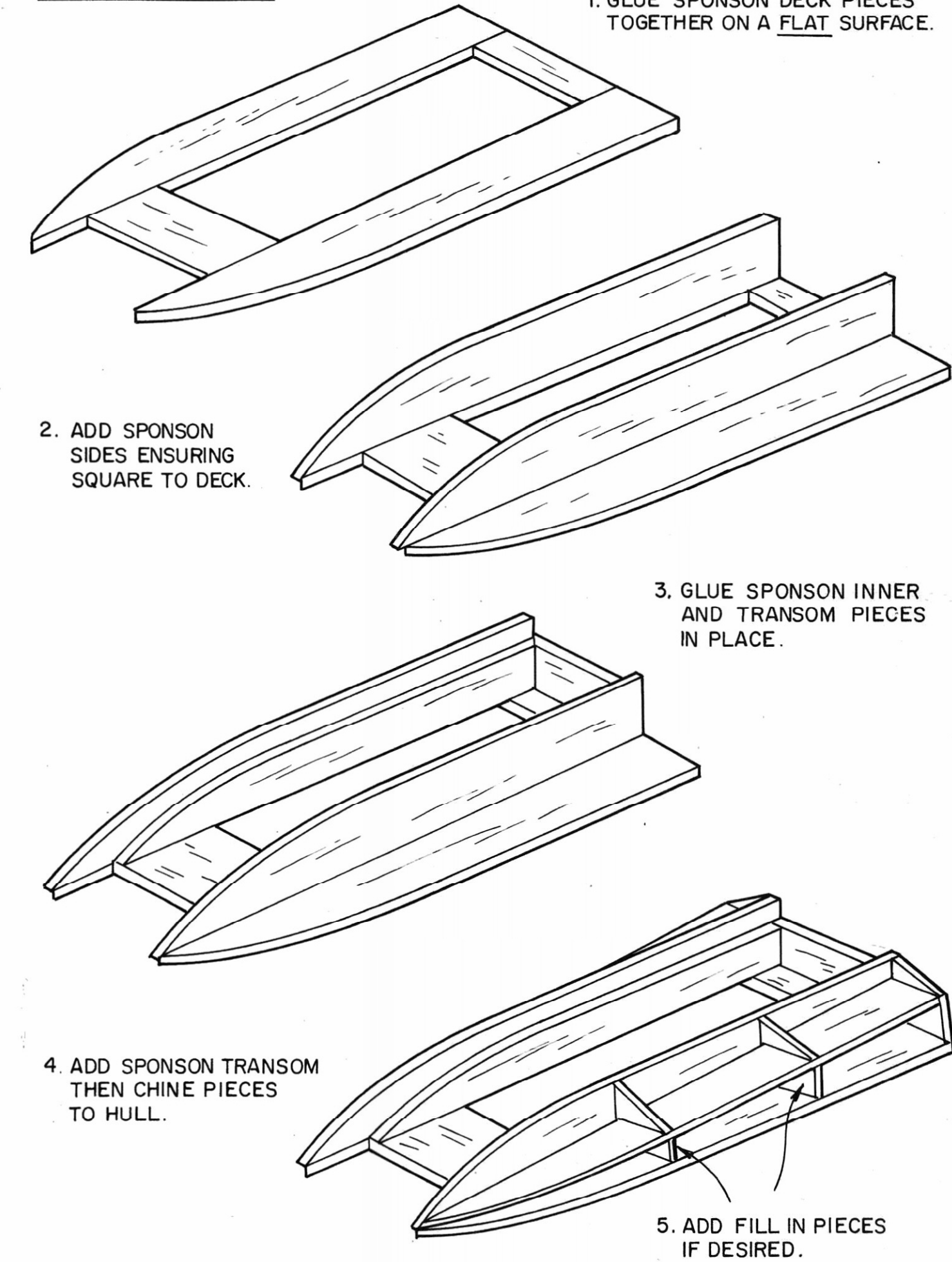

HULL SHEETING SEQUENCE USE 1/8" (3mm) BALSA SHEET

HULL SECTIONS NOT TO SCALE

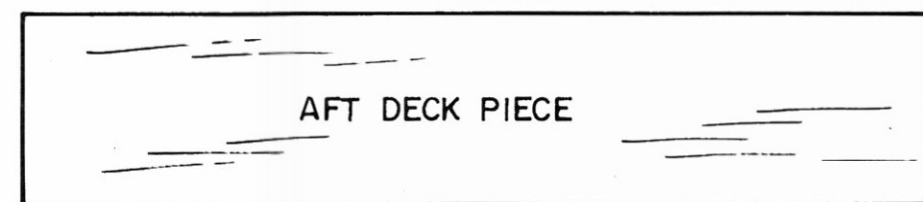
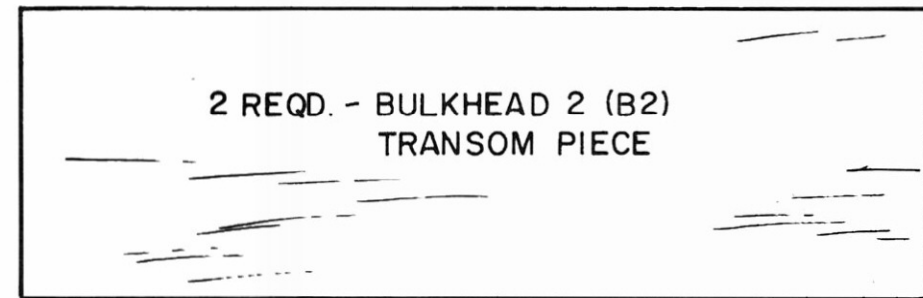
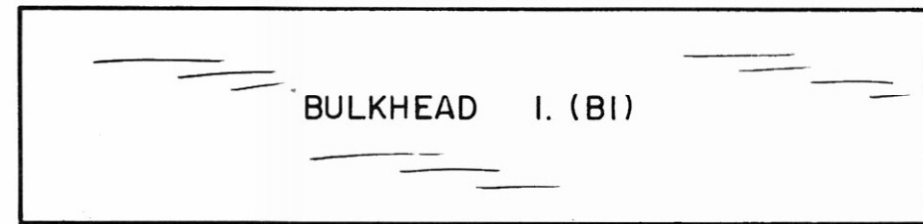
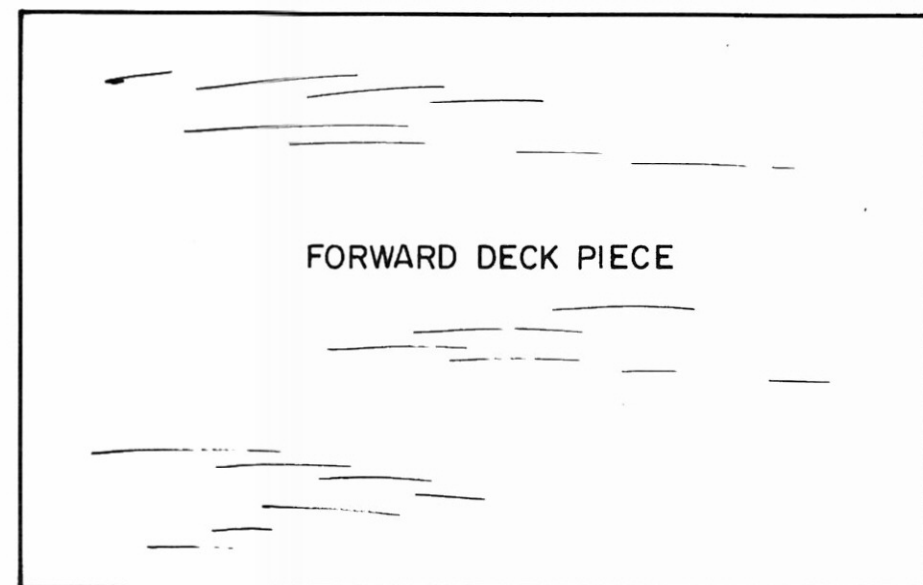
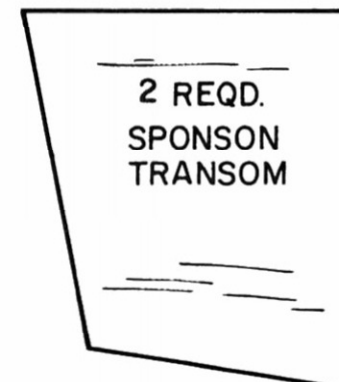
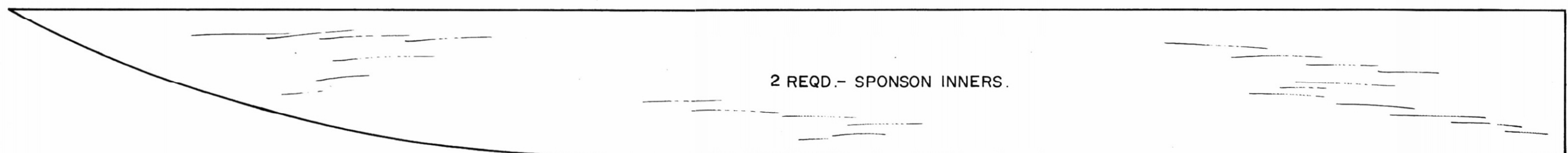
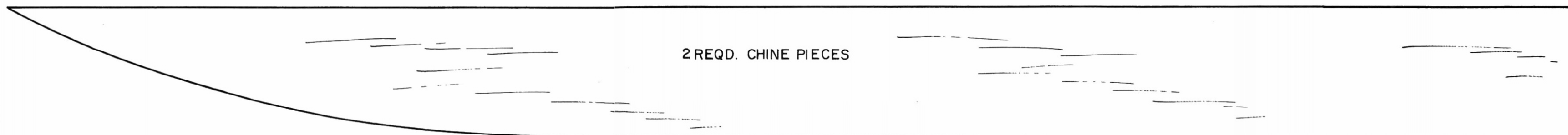
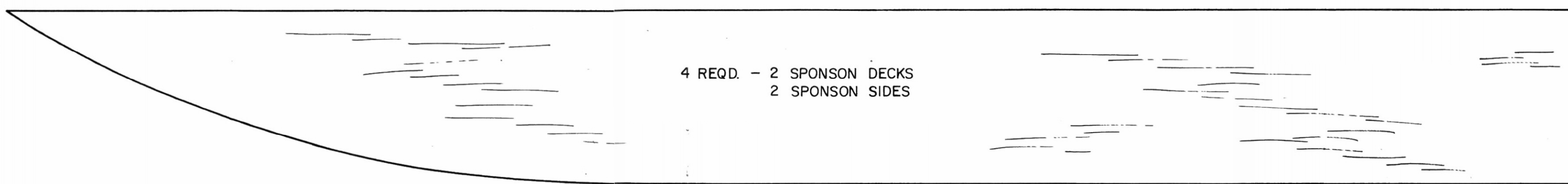
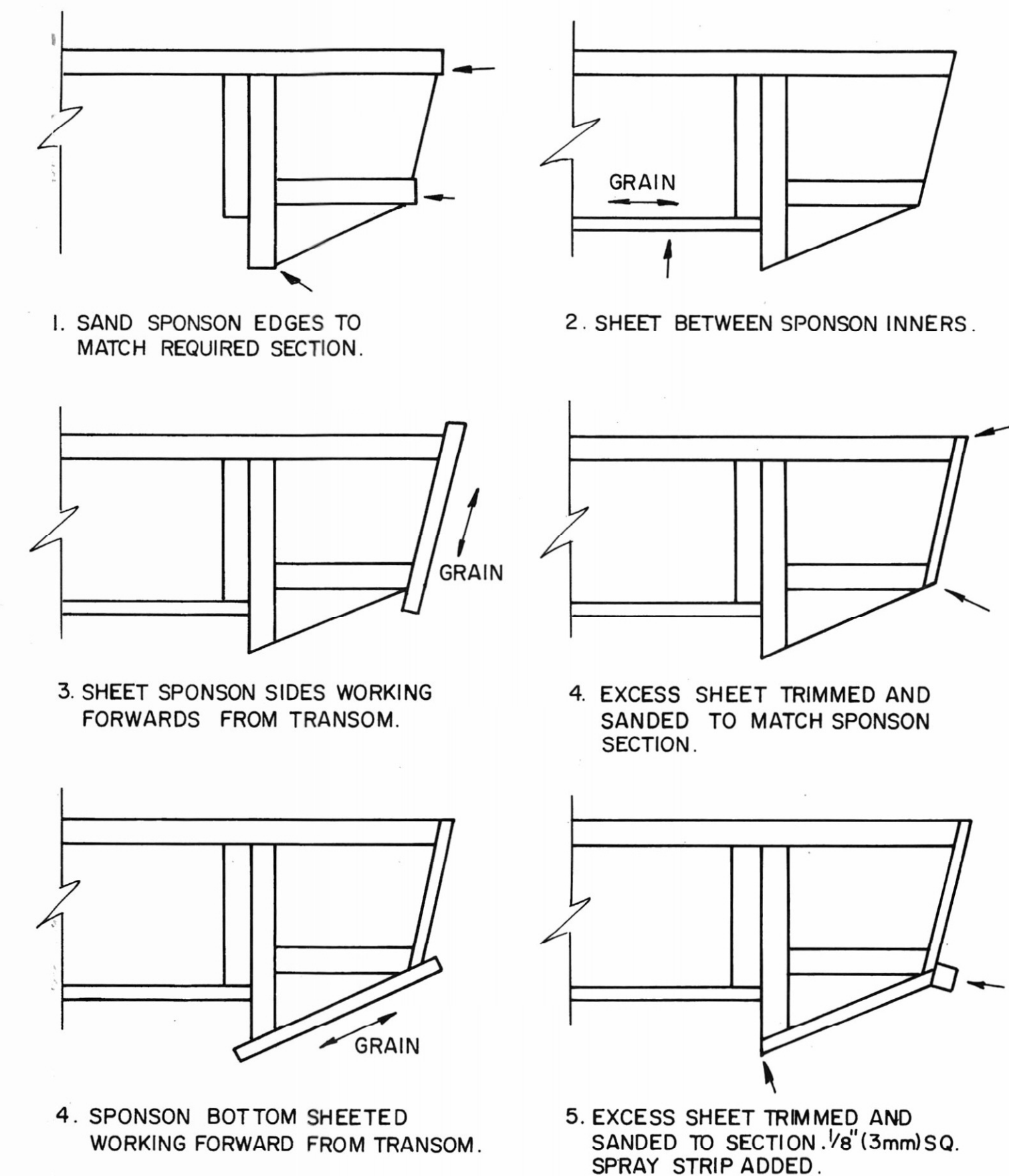

ALL HULL PIECES TO BE CUT FROM 3/16" (5mm) BALSA SHEET.

