

WING SECTION A-A

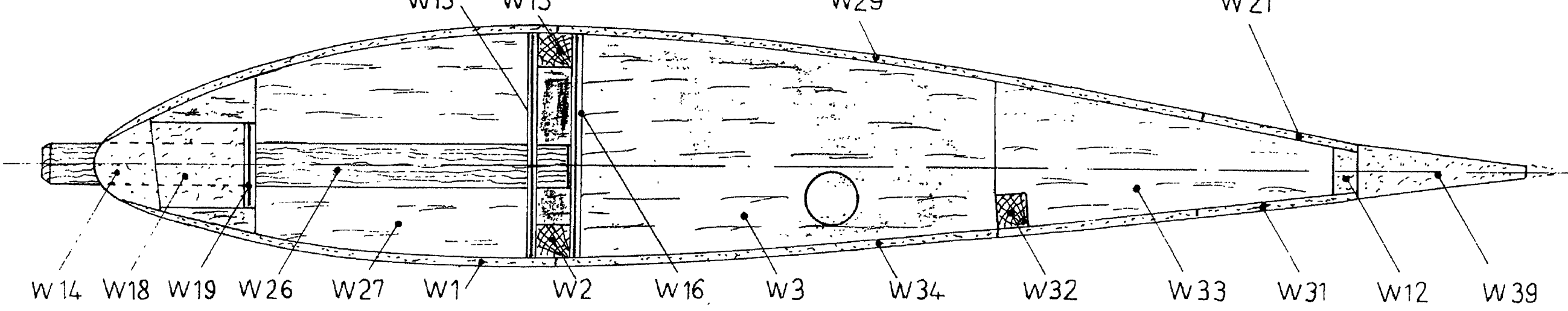

WING SECTION B-B

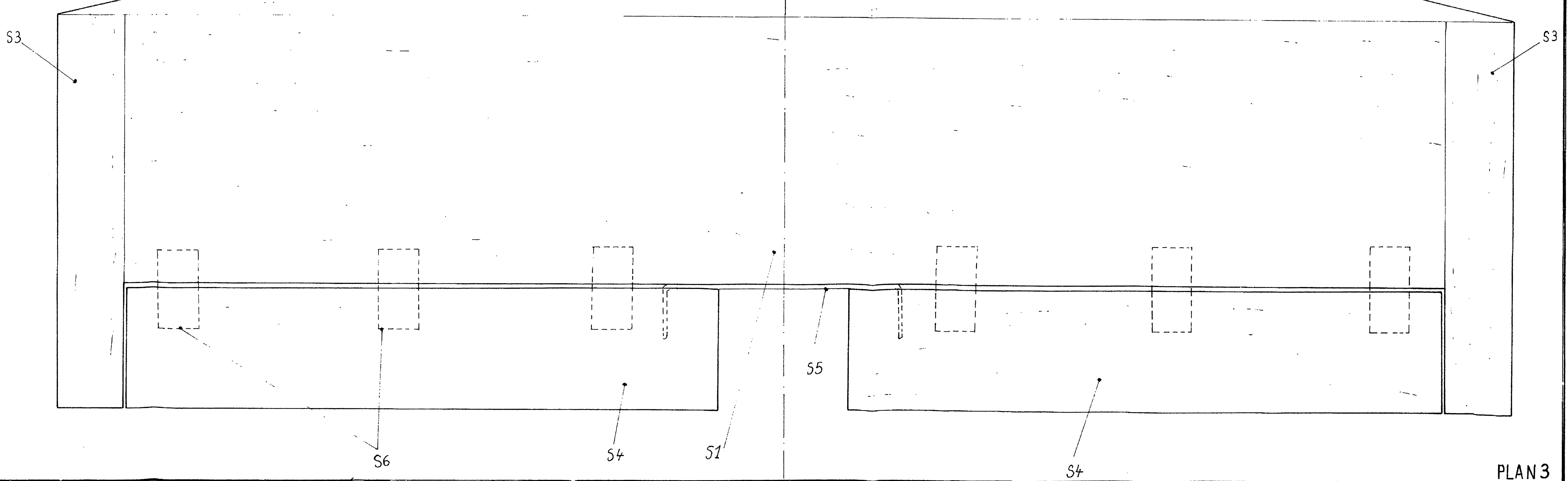
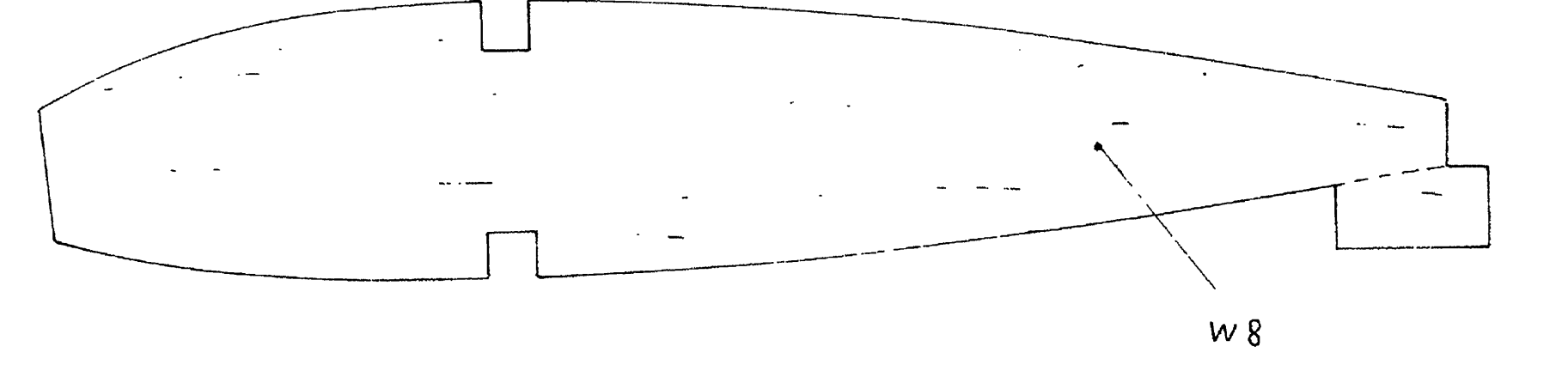
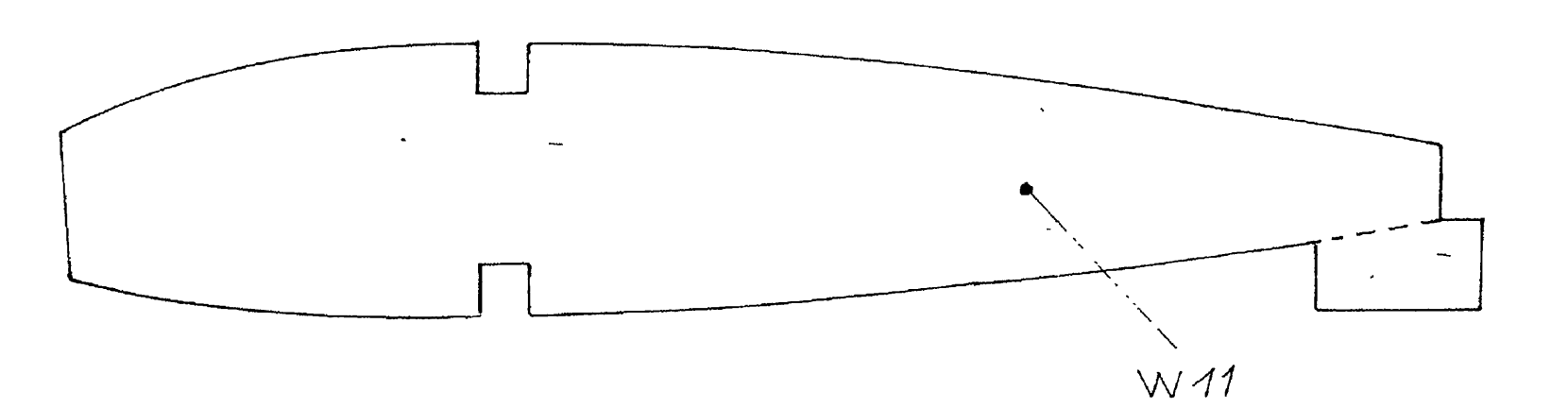
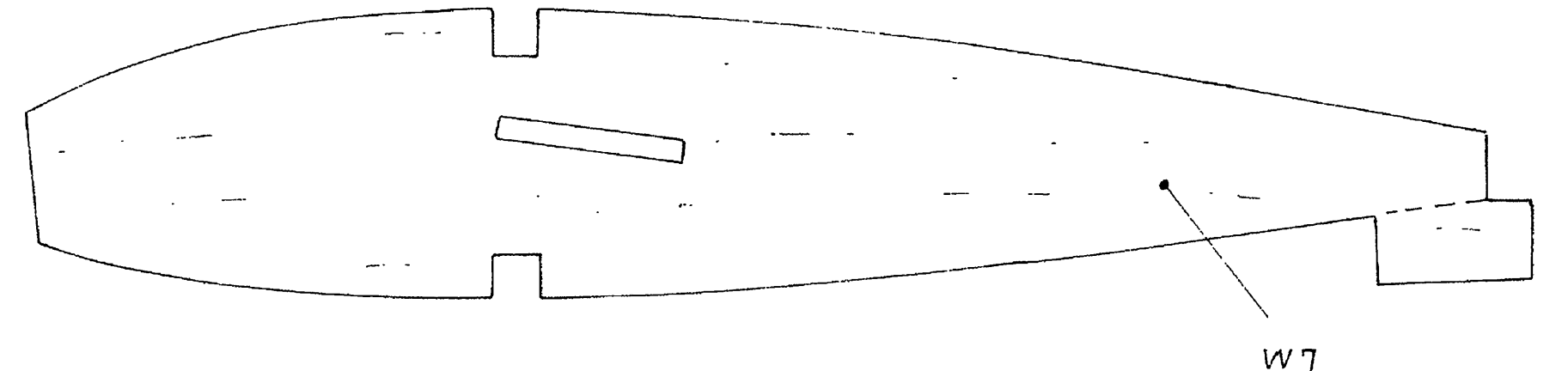
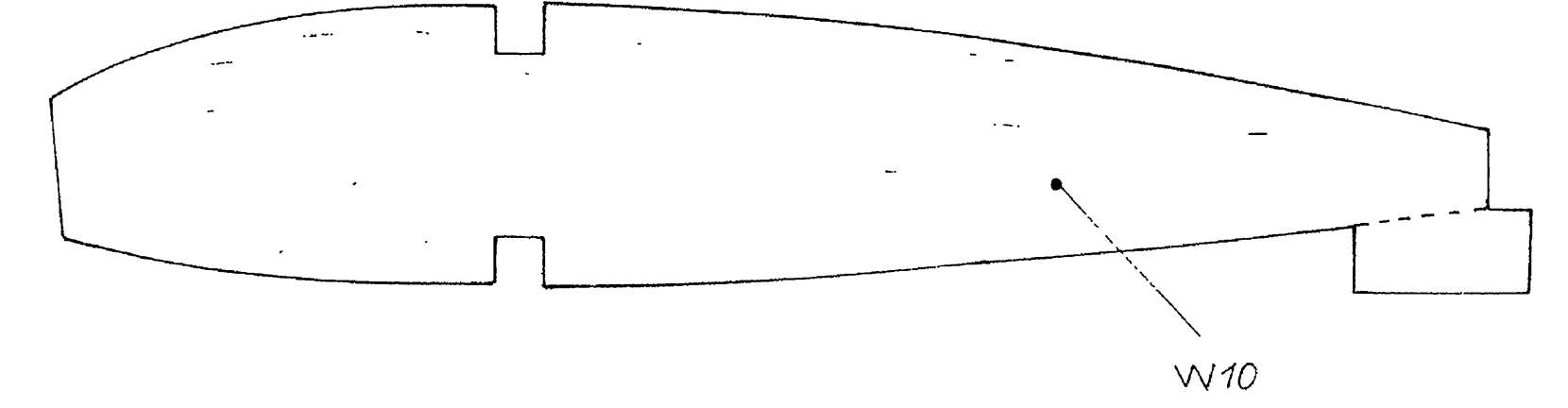
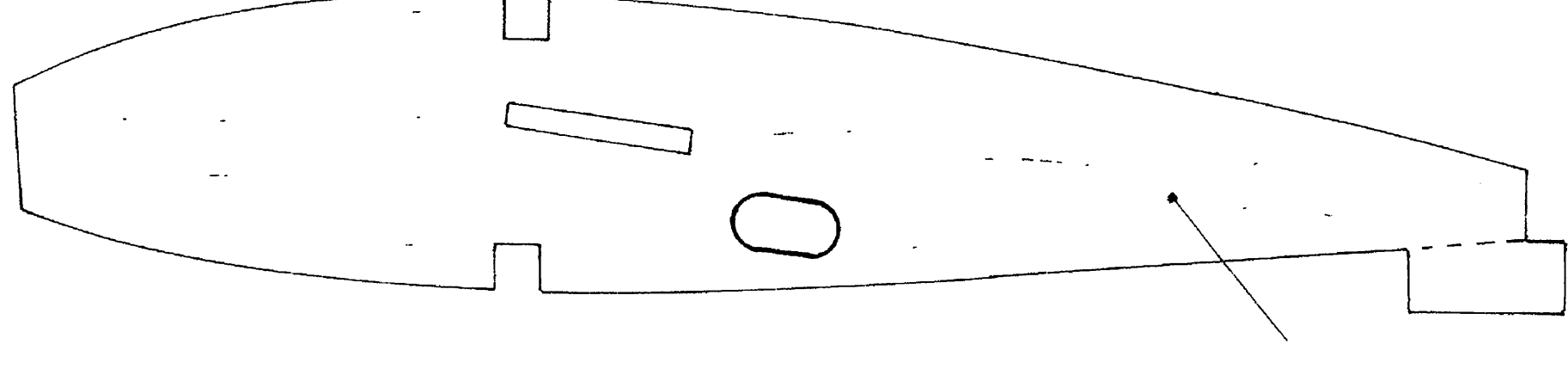
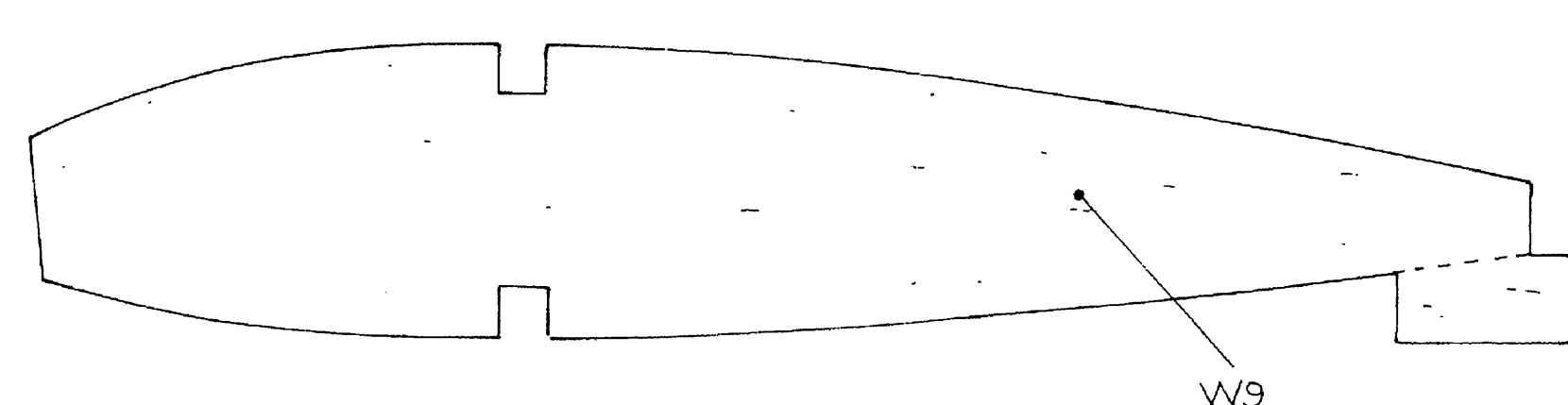
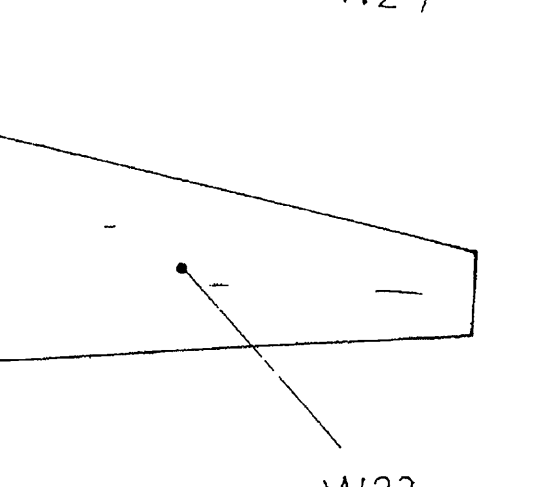
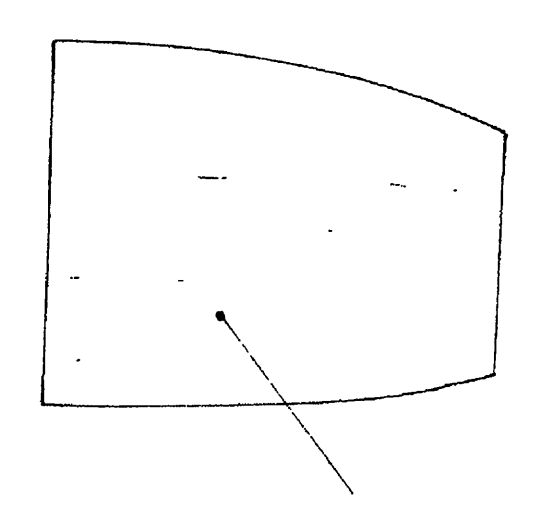
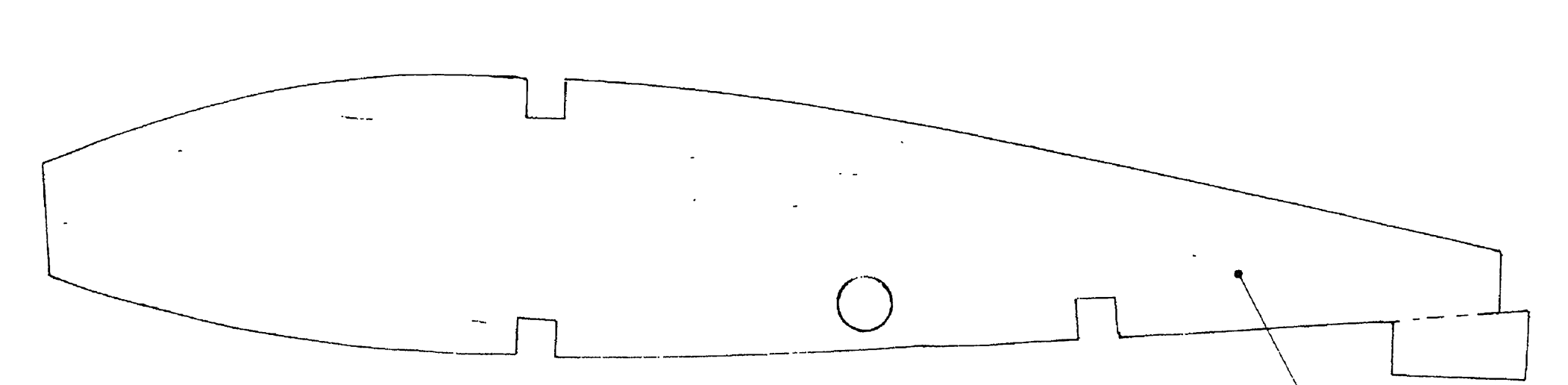
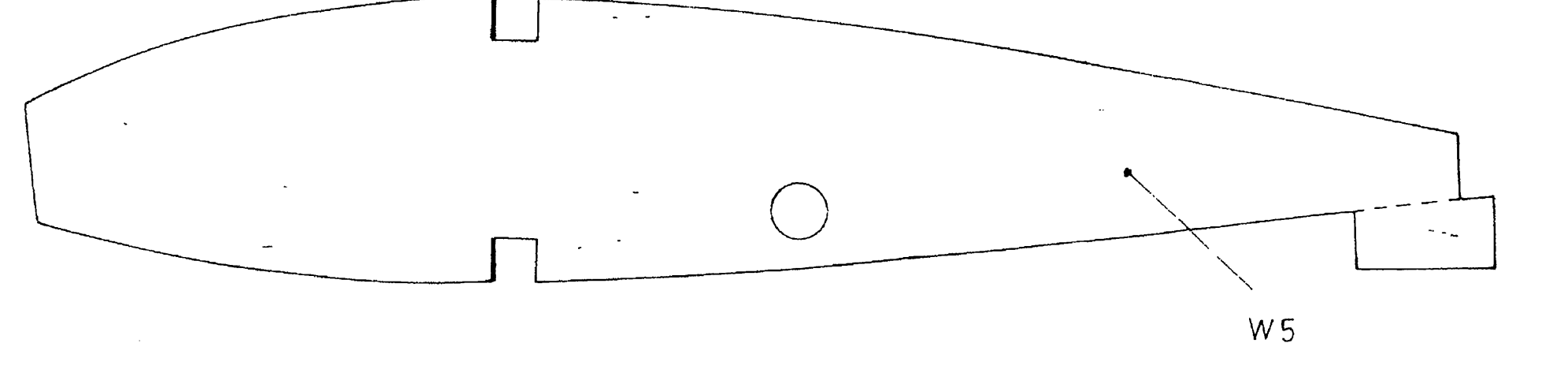
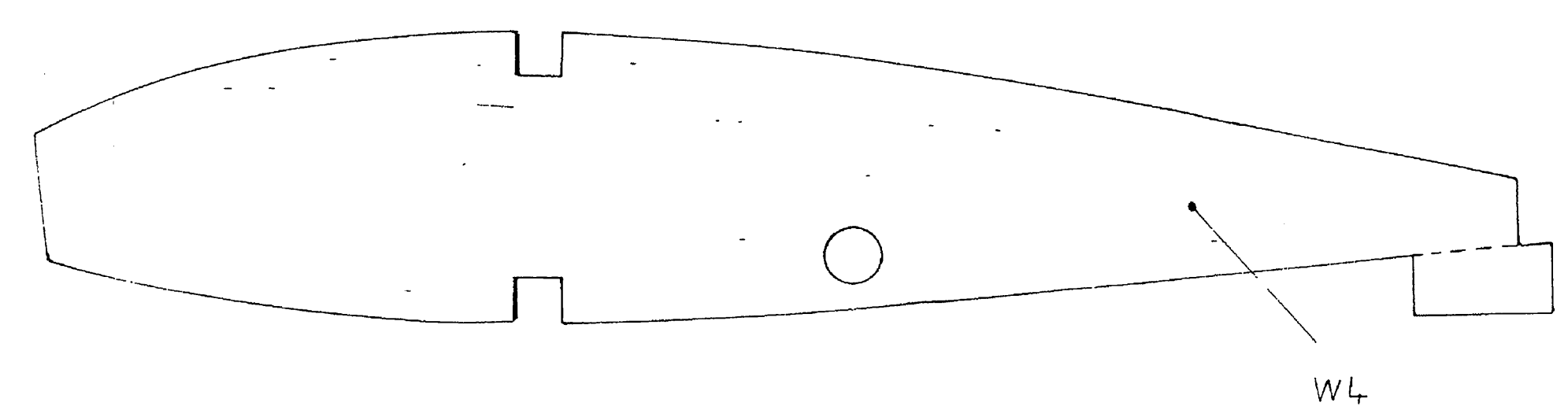
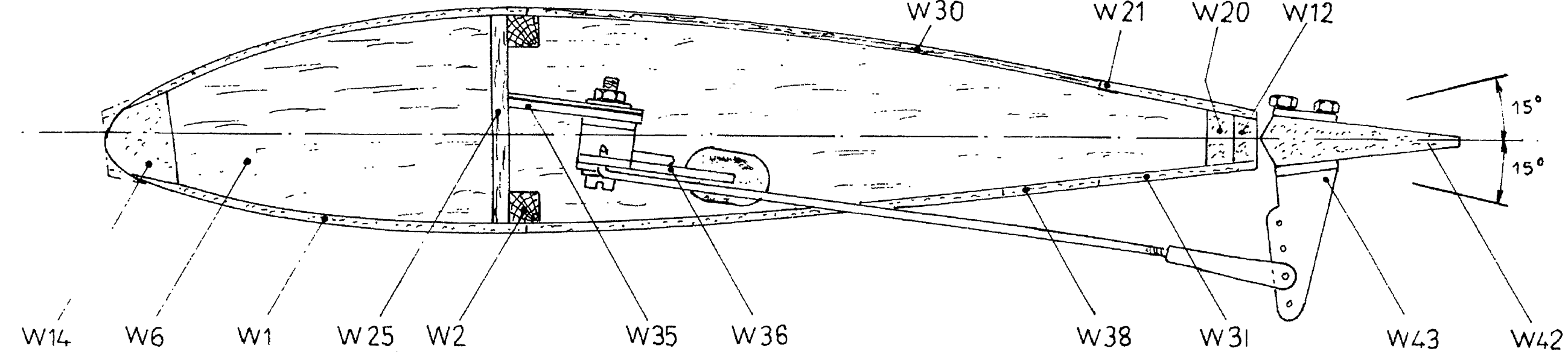

FUSELAGE TOP VIEW

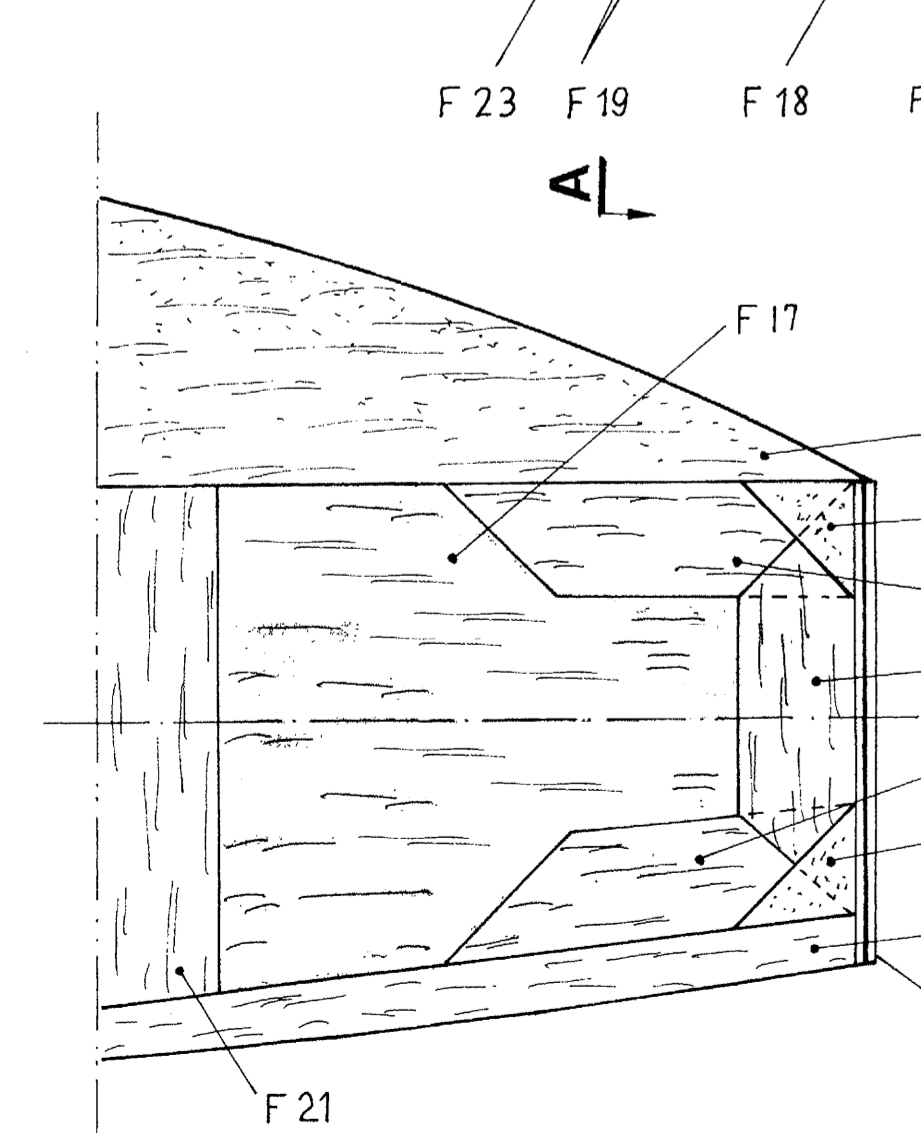
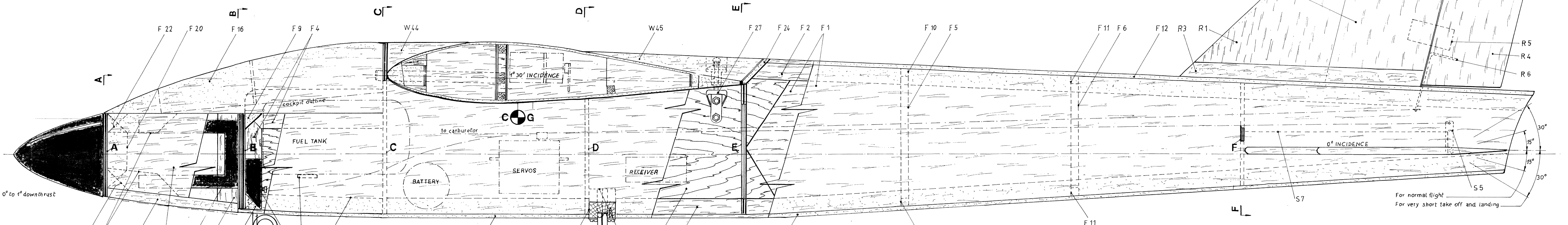
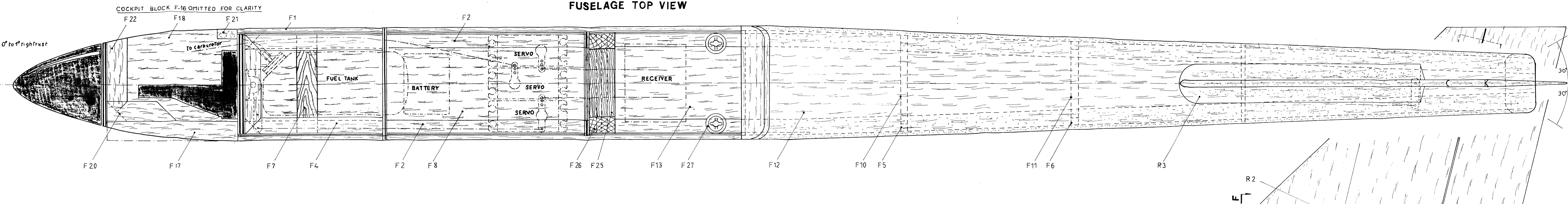

NOSE RIGHT SIDE VIEW

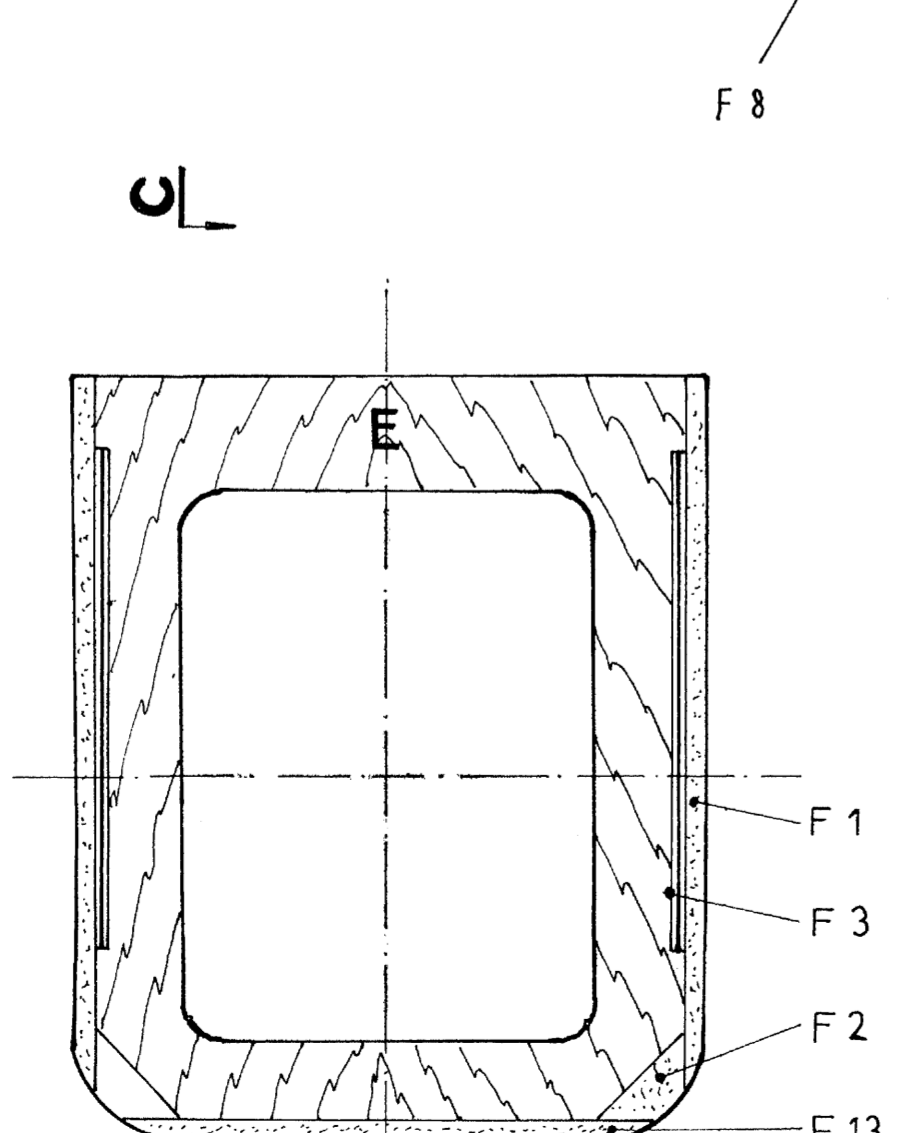
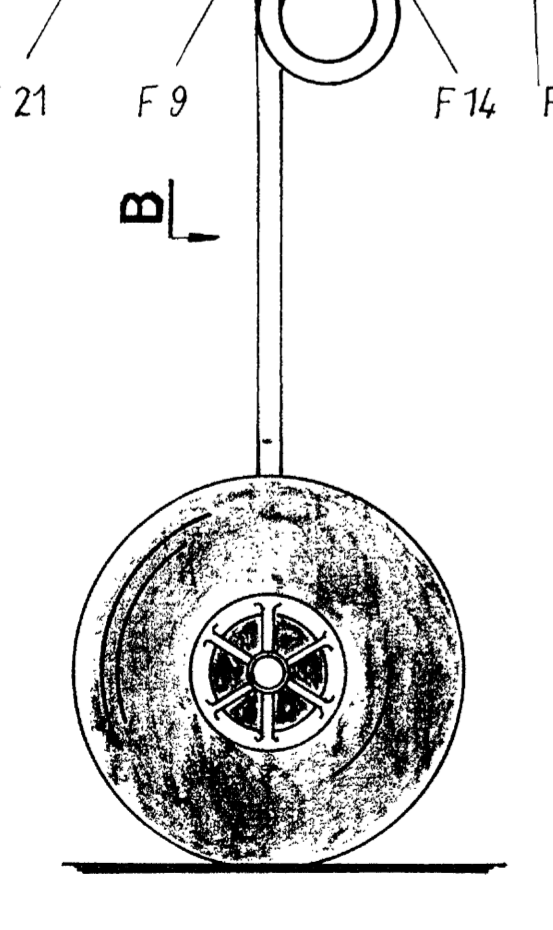

SECTION E-E

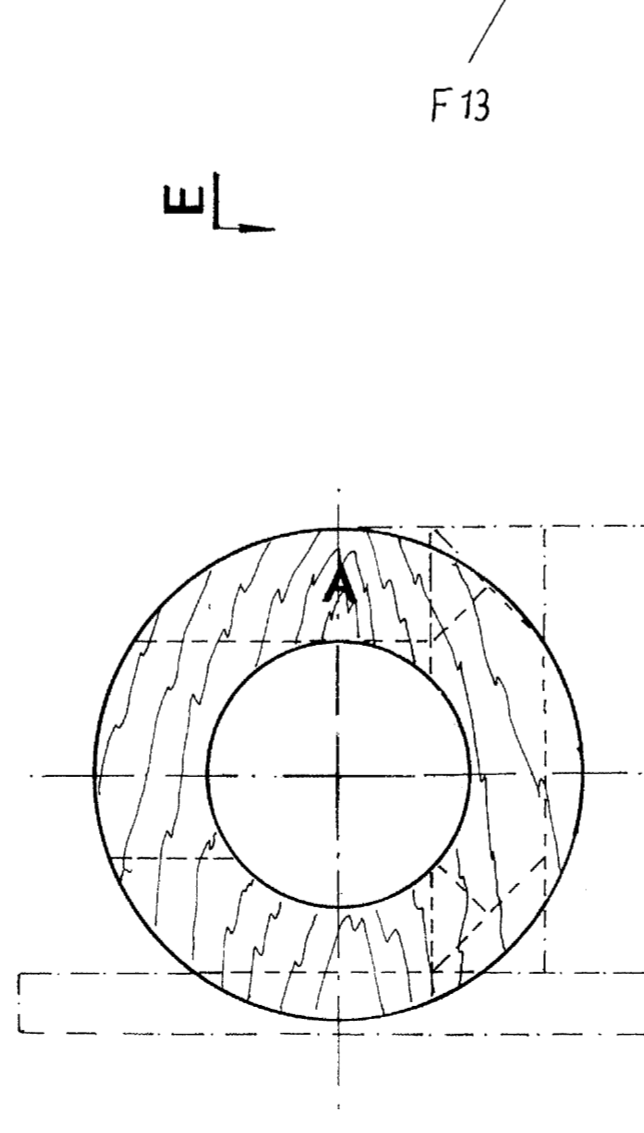
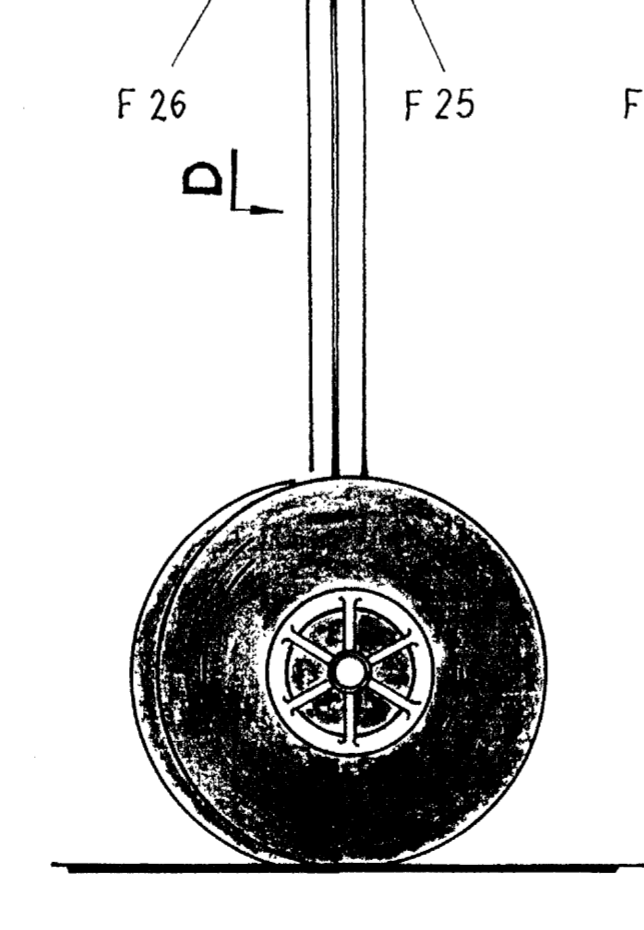

SECTION A-A

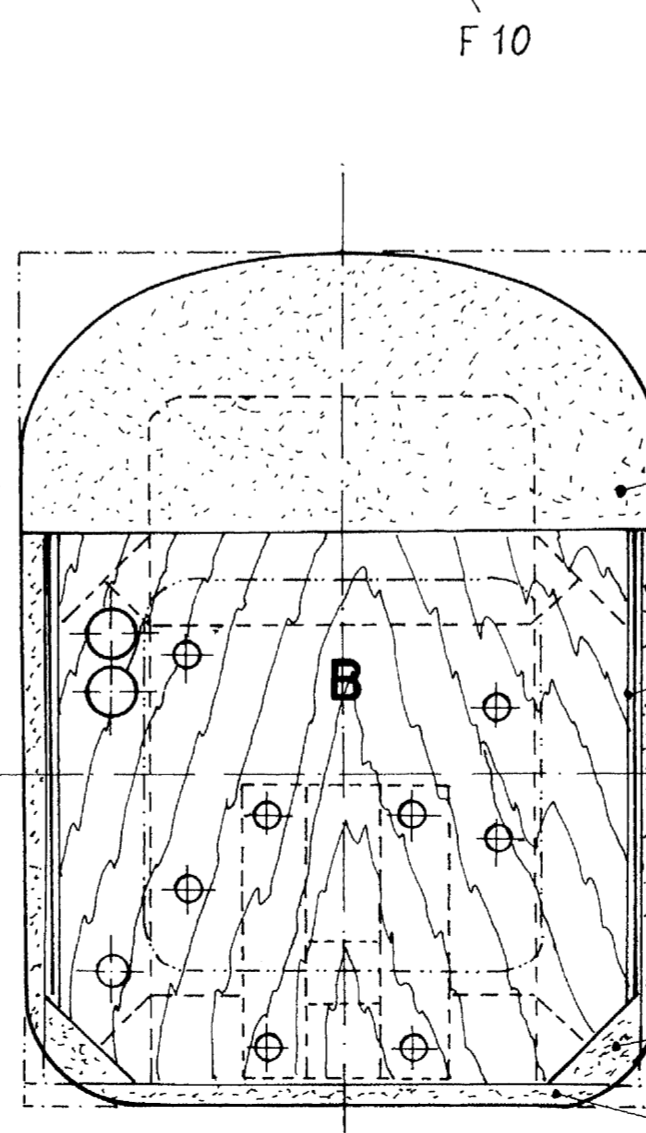

SECTION B-B

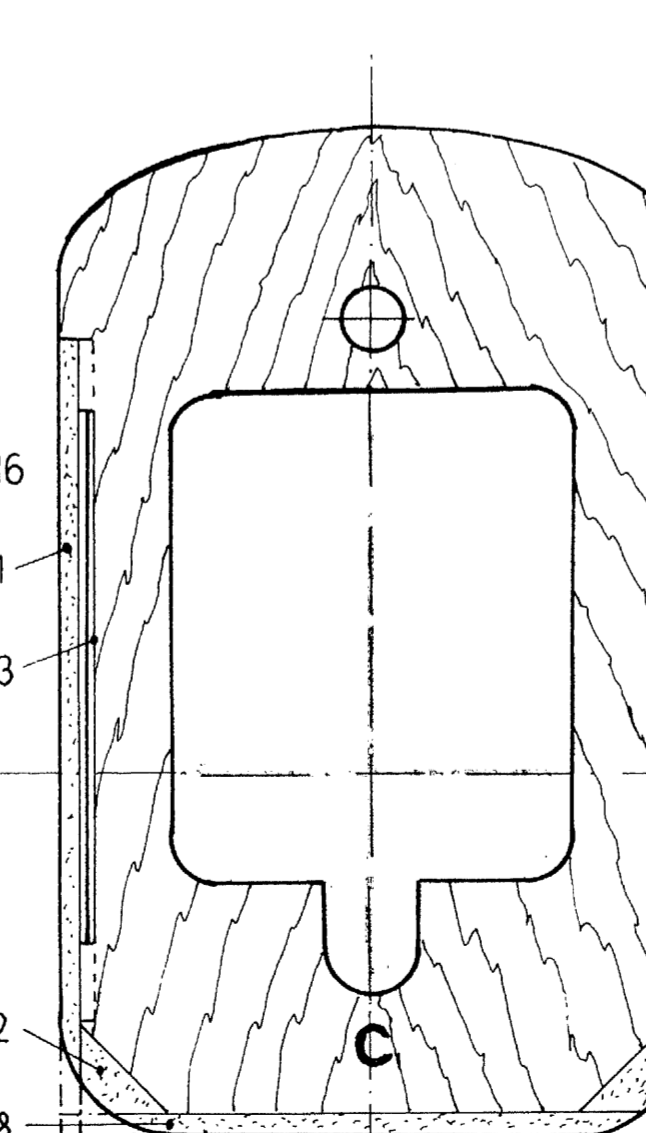

SECTION C-C

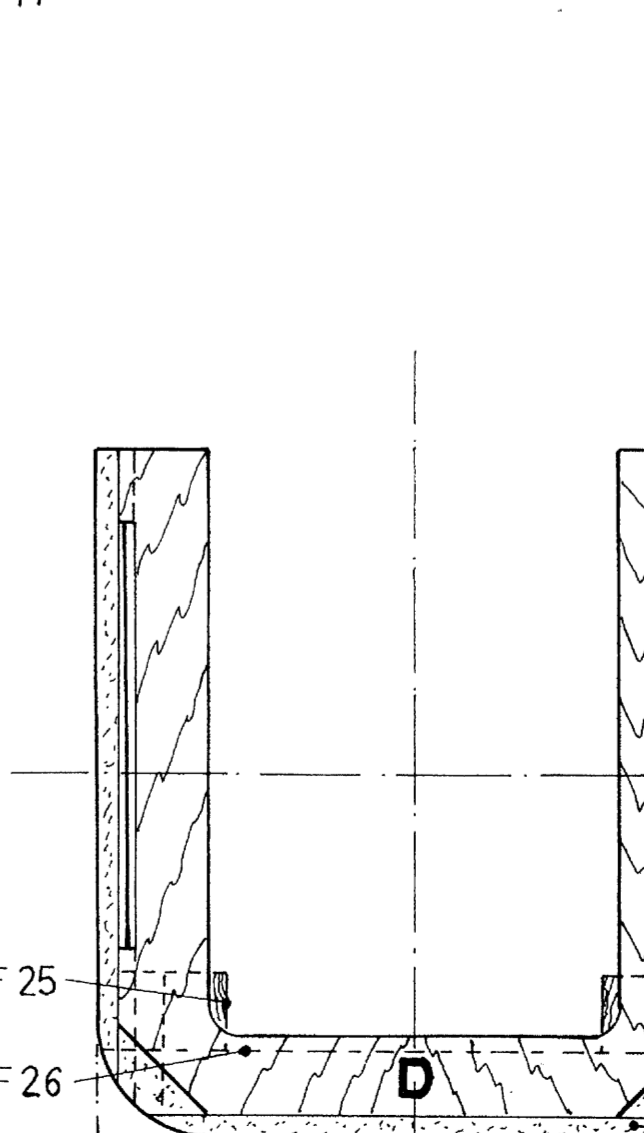

SECTION D-D

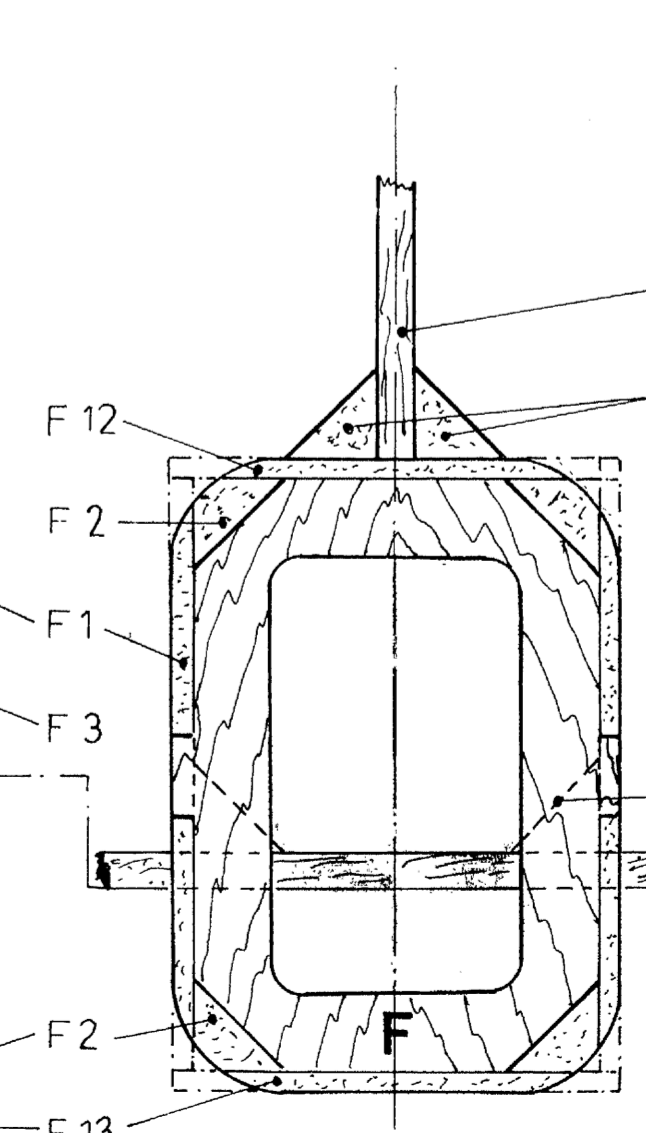

SECTION F-F

JET-40

TECHNICAL DATA

Wingspan	1400 mm
Fuselage length	1120 mm
Wing area	35 dm ²
Stab area	9,3 dm ²
Total area	44,3 dm ²
Empty weight	1300 gr
Engine	5 to 6,5 cc
Radio control	4 channels