



Bottom Skin – 8 2mm ply

Make 2



Chine Stringer – 3 6mm ply    Make 2



Side skin – 7 2mm ply

Make 2

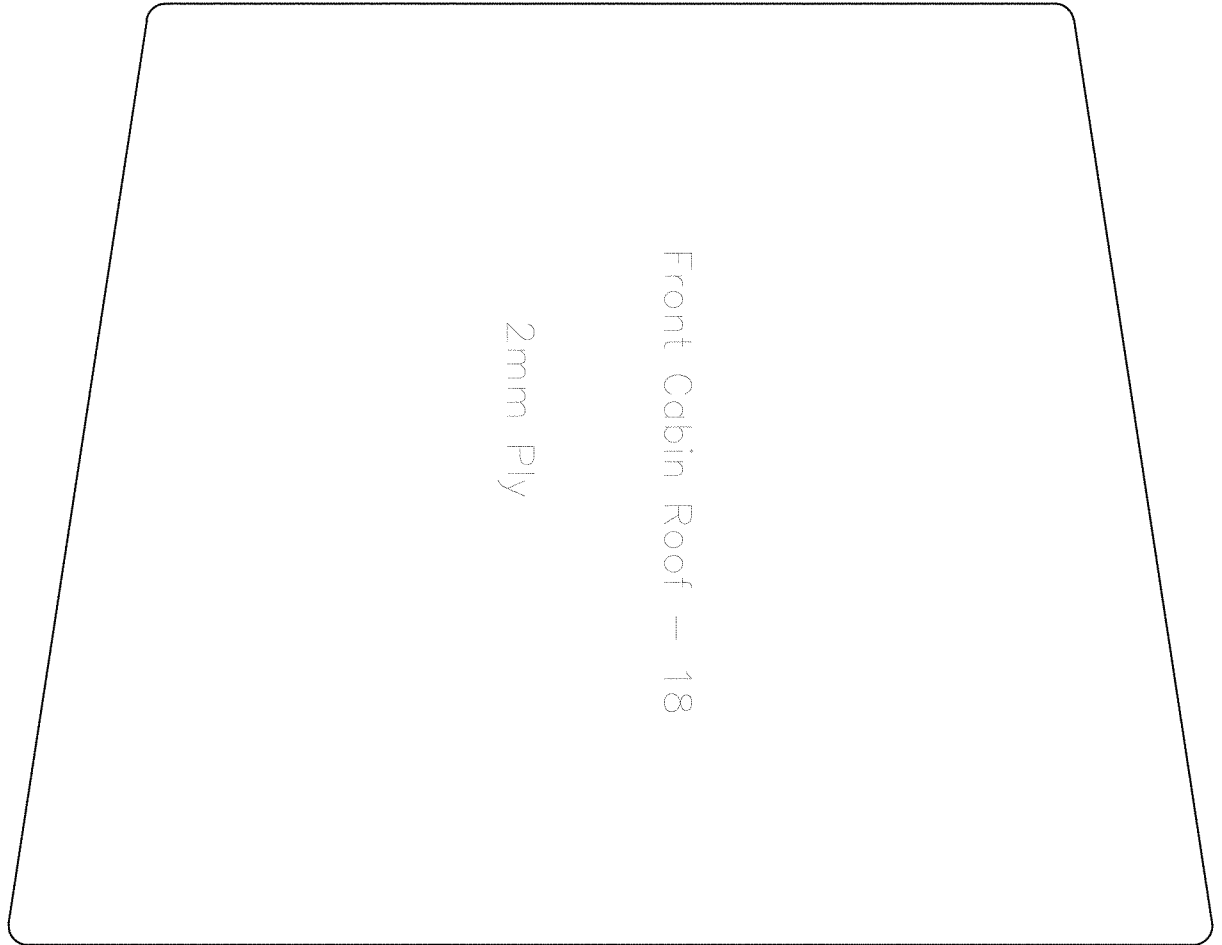
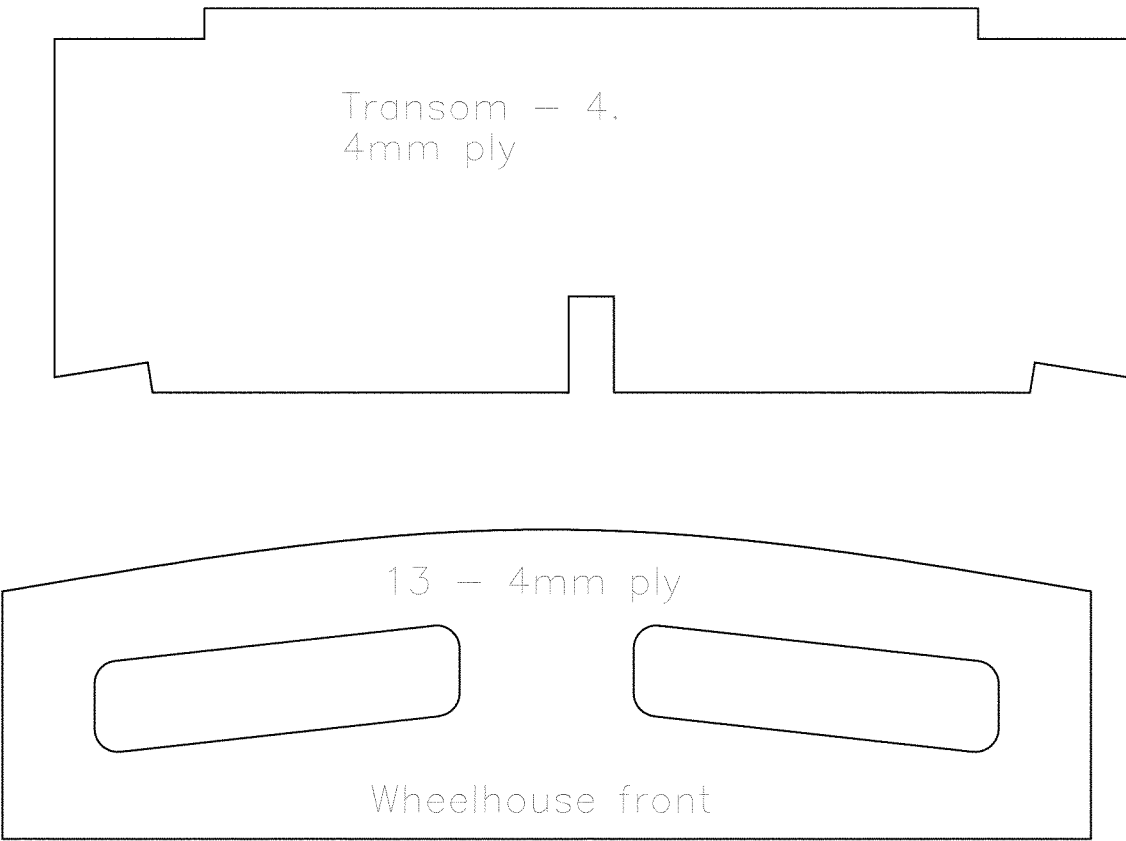
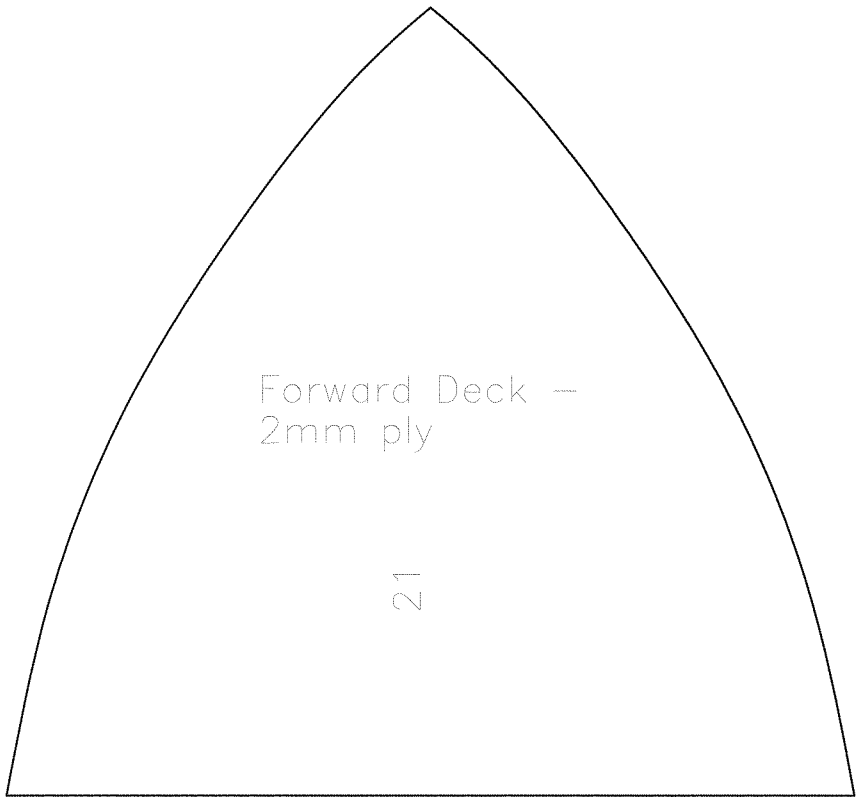
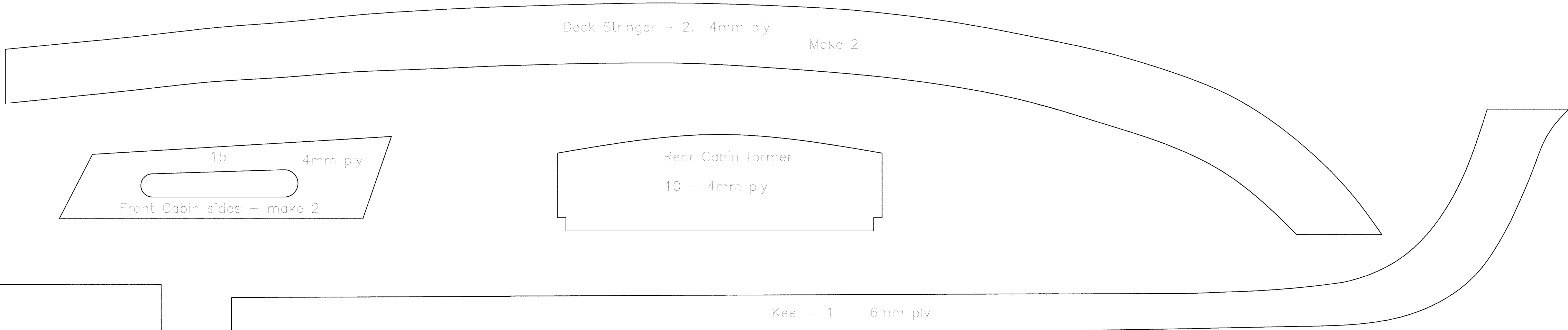

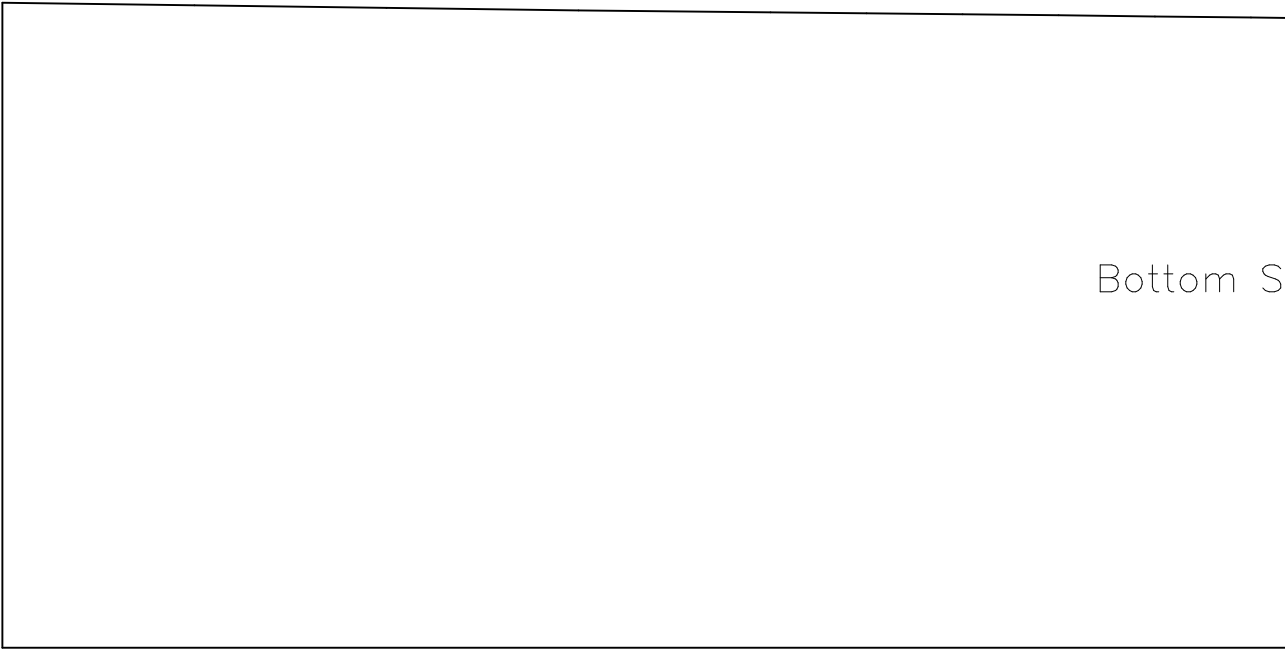

Bottom S

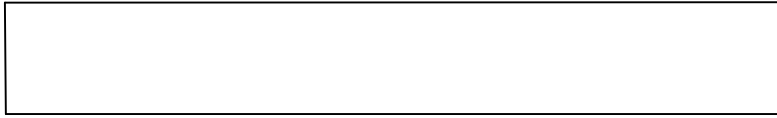

S

Skin – 8 2mm ply

Make 2

Chine Stringer – 3 6mm ply Make 2

Side skin – 7 2mm ply

Make 2

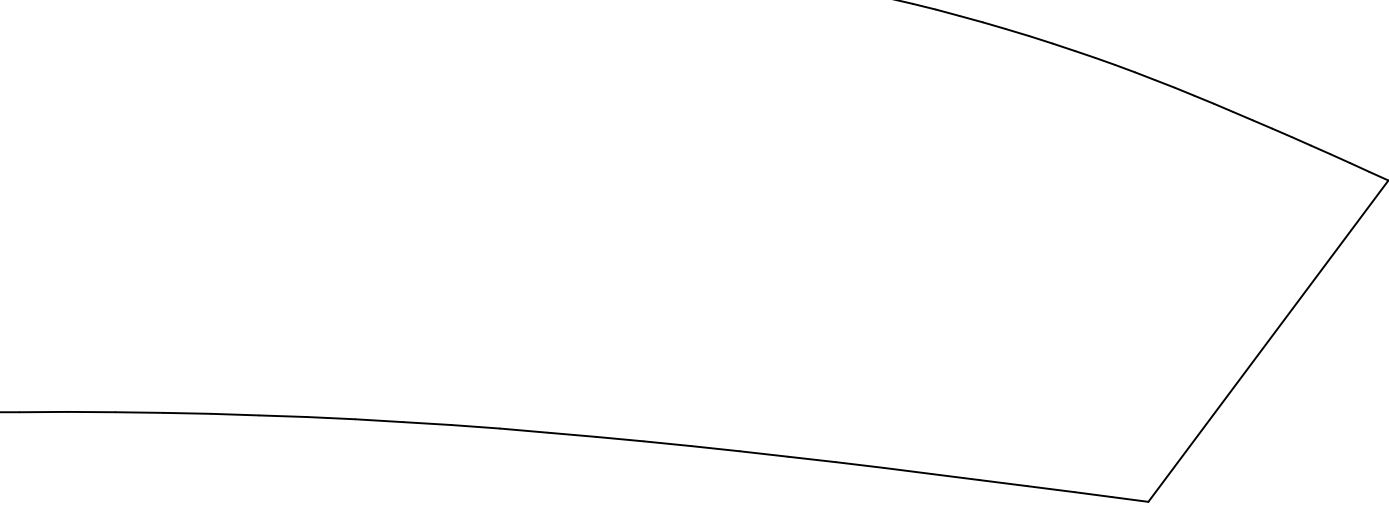
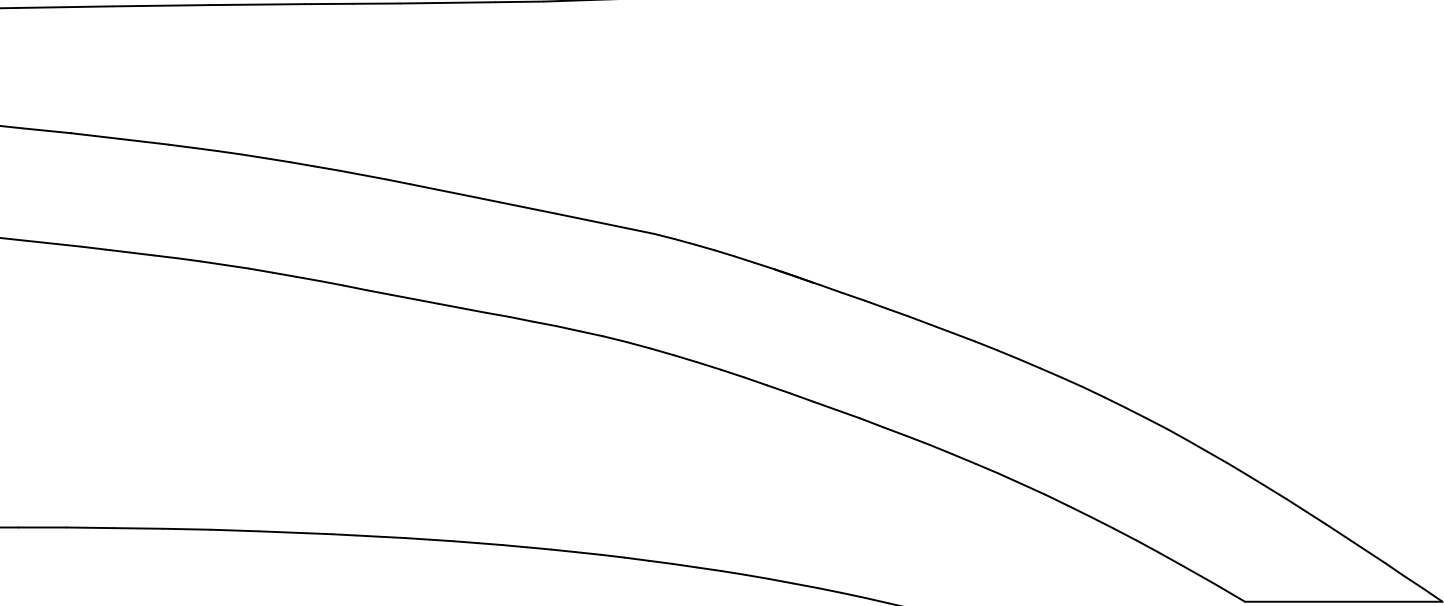
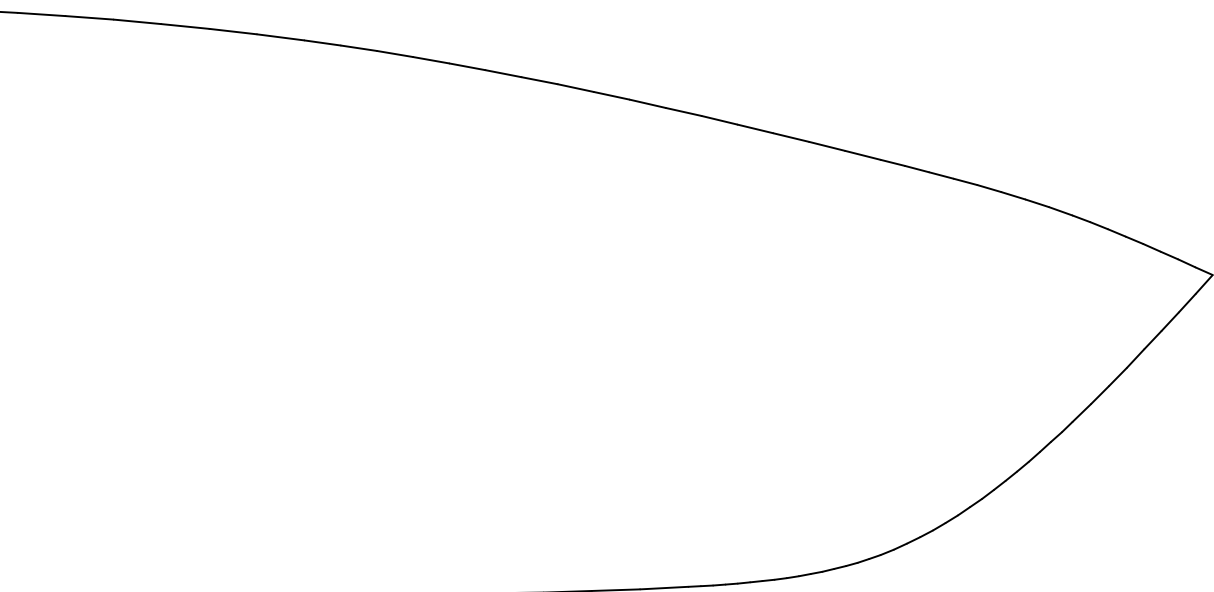

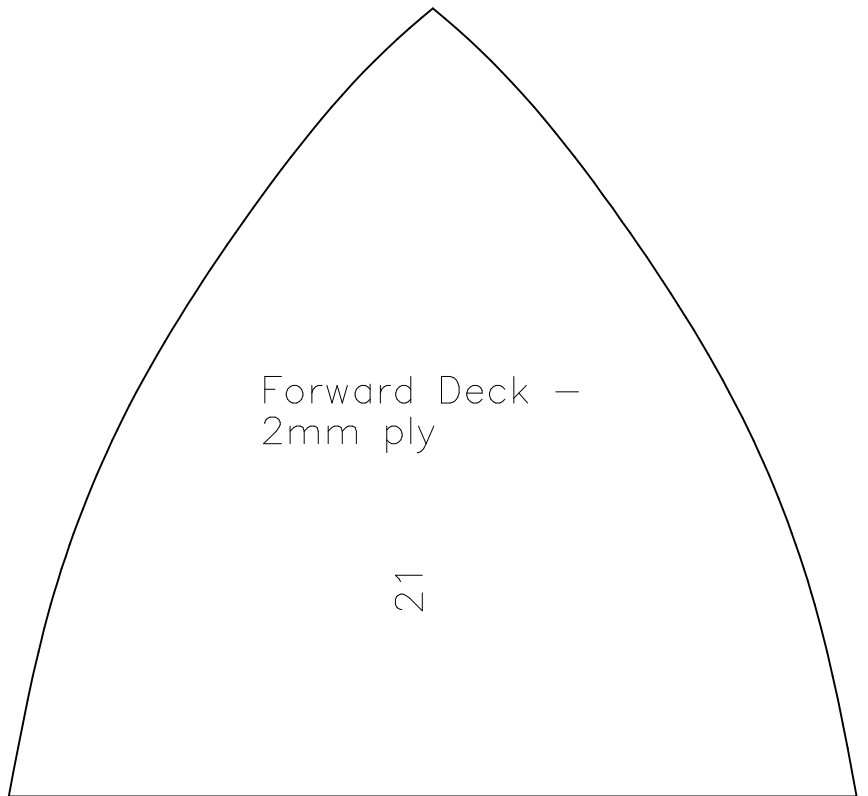
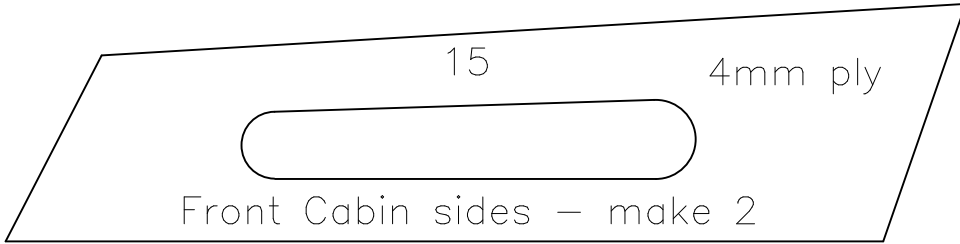
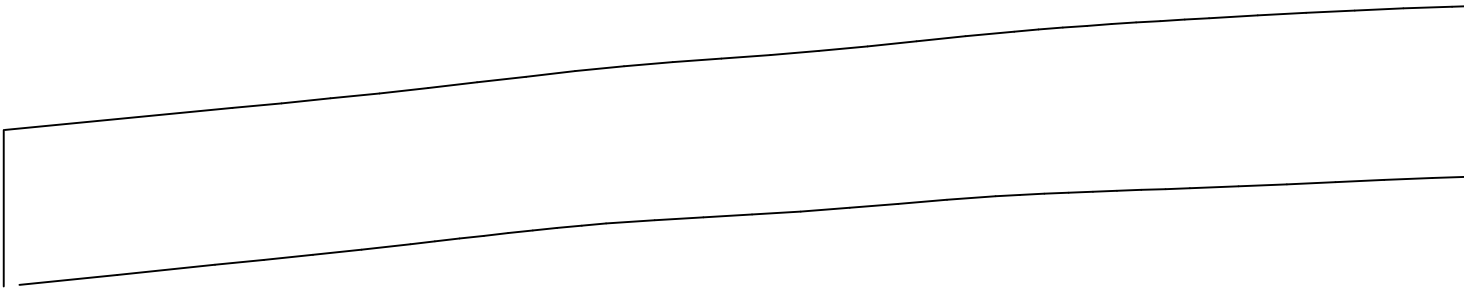

Deck Stringer – 2. 4mm ply

Make 2

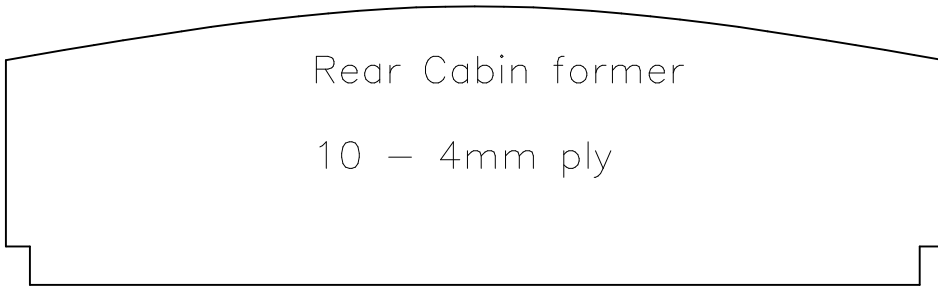

Rear Cabin former

10 – 4mm ply

Keel – 1 6mm ply

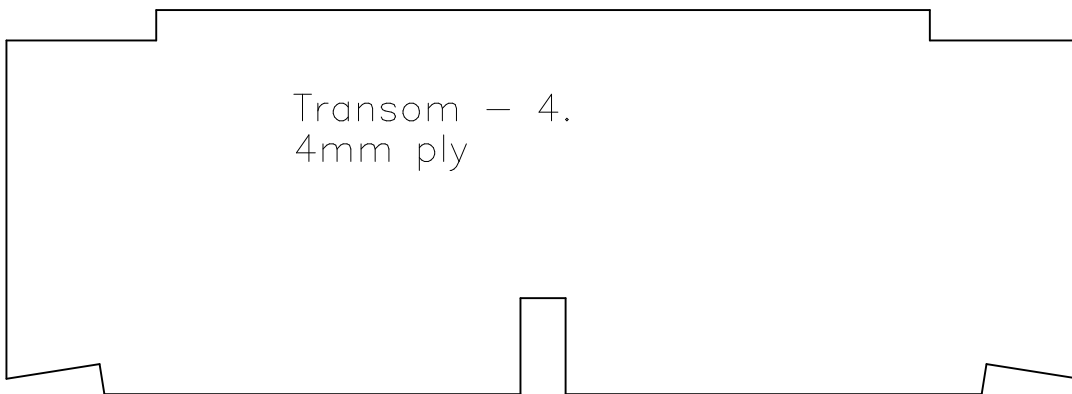

Transom – 4.  
4mm ply

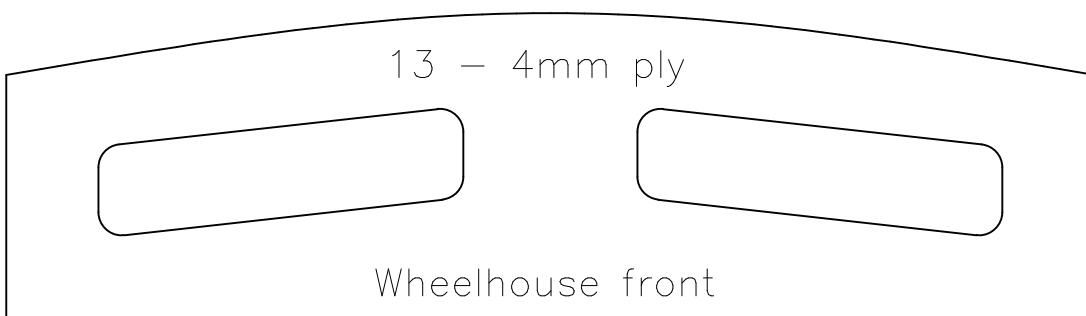

13 – 4mm ply

Wheelhouse front

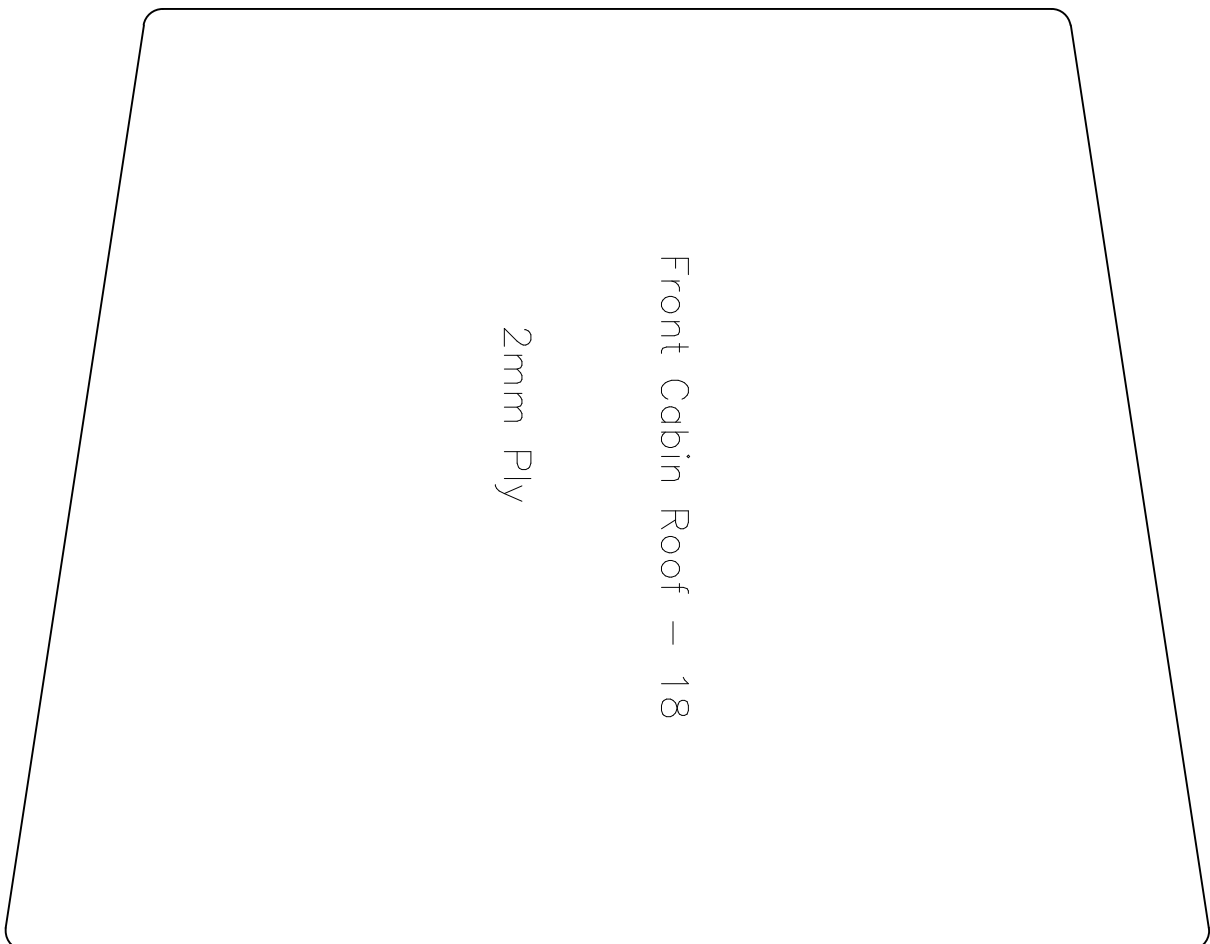
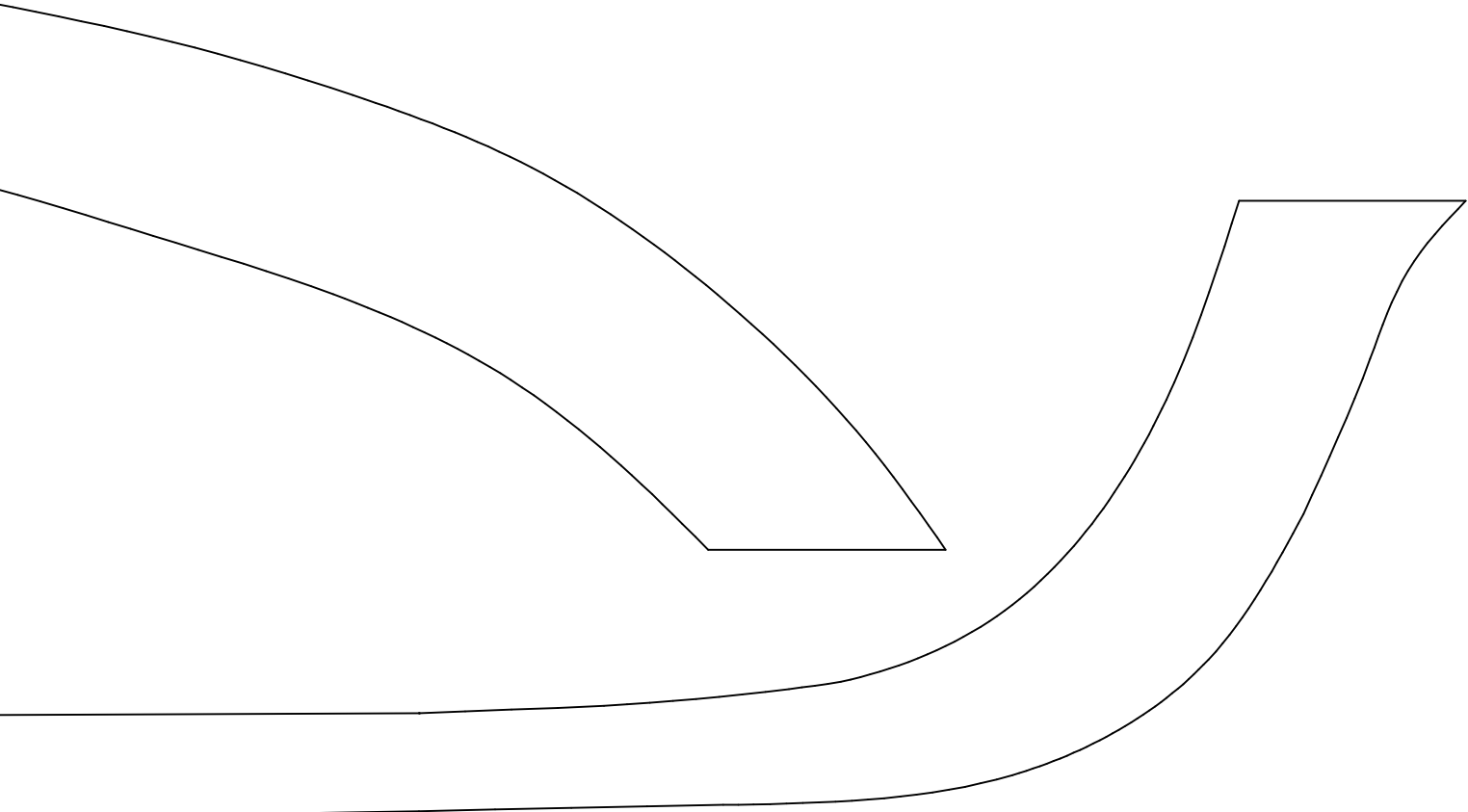

Front Cabin Roof - 18

2mm Ply

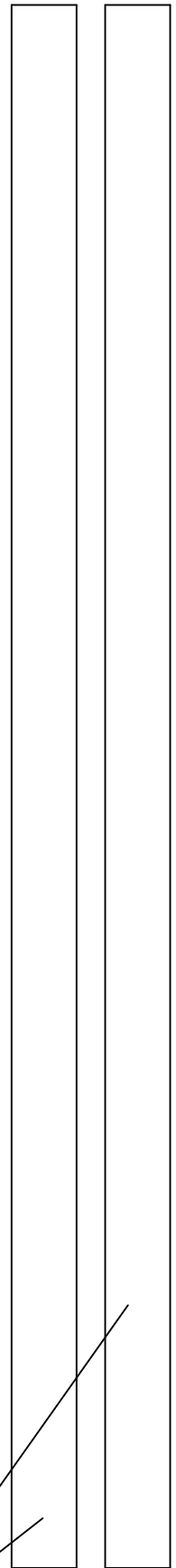
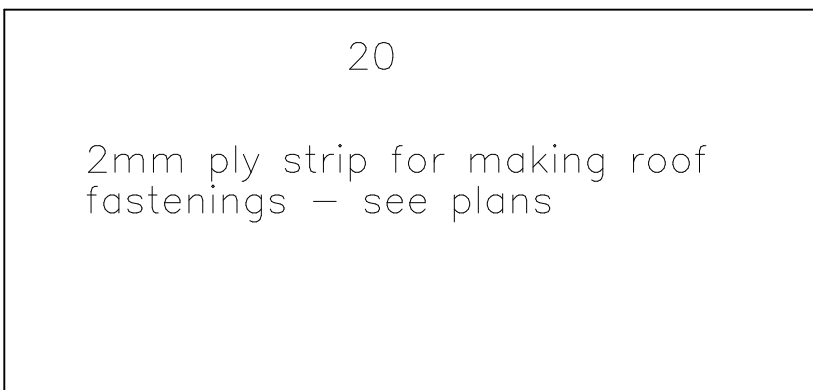
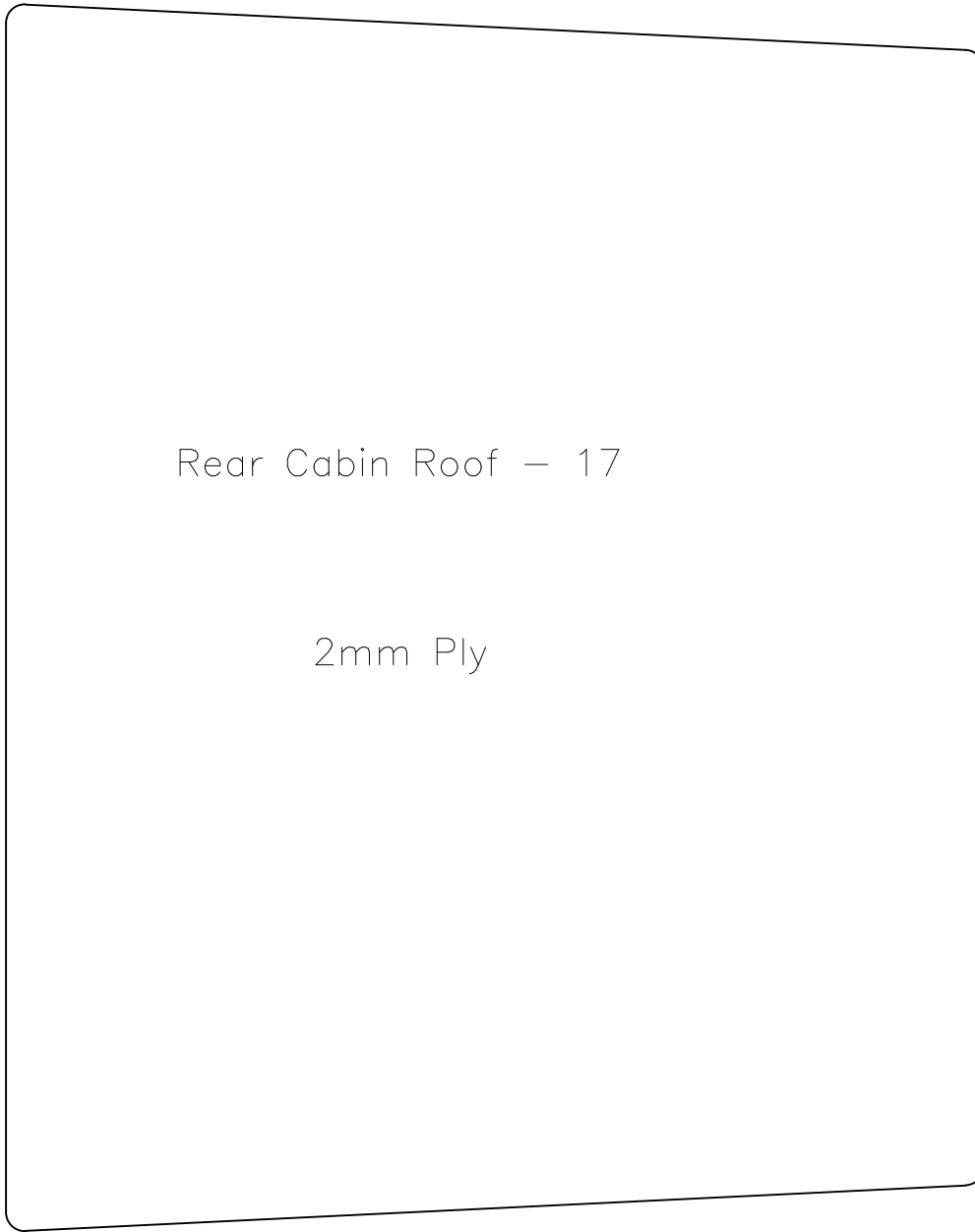
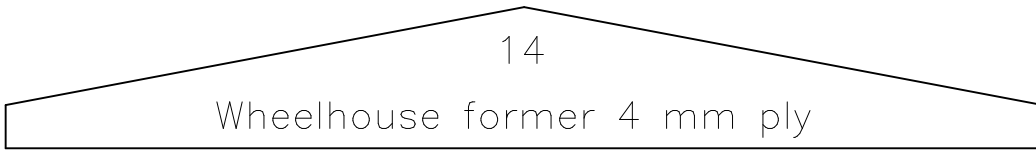

Keel Blocks (make 2) 5. 1/2 in square wood



Wood for 'C' supports/ 1/4 in square

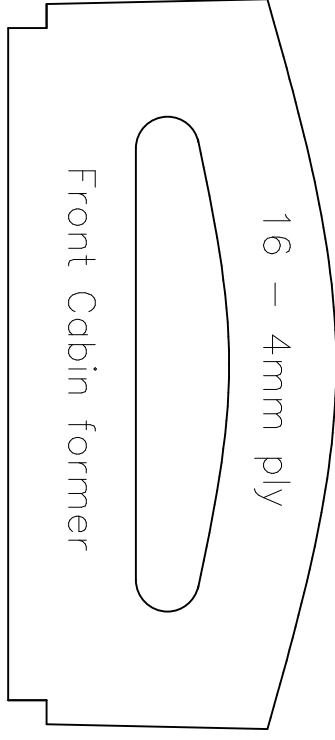

Small Midship former - 4mm ply 12

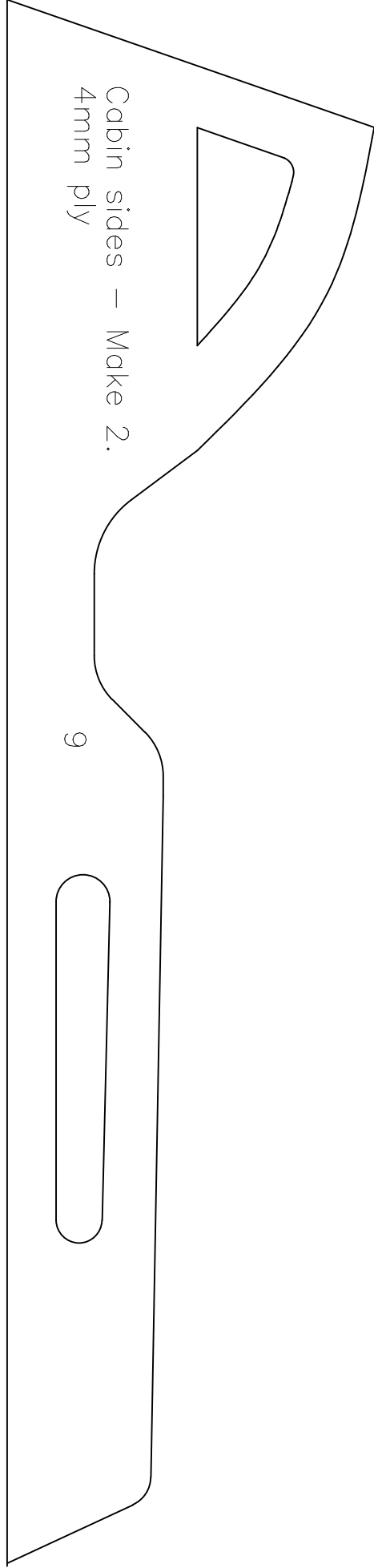

Large Midship former – 4mm ply

11

Die-cut parts for the Yeoman MINX 20" Cabin Cruiser

The original kit also contained:

Item

- 23 – 2 Rubbing Strakes – 1/8" x 1/16" x 22" – spruce or obechi
- 24 – 1 piece of acetate for window glazing
- 25 – 1 packet of gimp nails

In the original kit, Part 15 and part 9 were connected, being die-cut from the same piece of wood, and needed to be sawn apart. See illustration below:

