

FIBREGLASS COWL - HOBBYPOXY BALLOON METHOD MAKE CUT-OUTS AS REQUIRED FOR EXHAUST AND NEEDLE VALVE - FOR SCALE CUT-OUTS SEE FRONT VIEW.

62" WINGSPAN - 620 SQ INCHES - .35 TO .60 ENGINES
DESIGNED & DRAWN BY GENE ROGERS

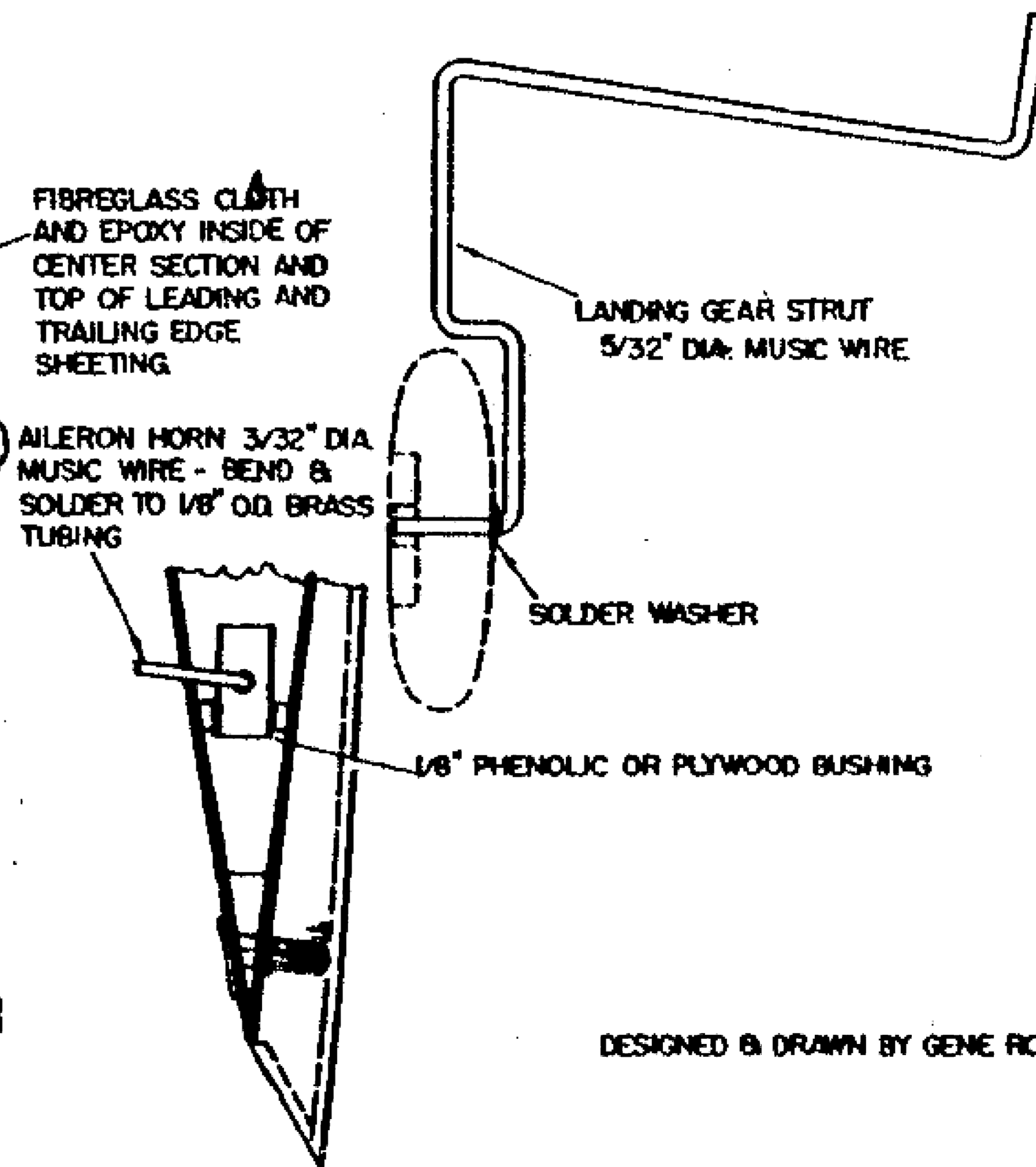
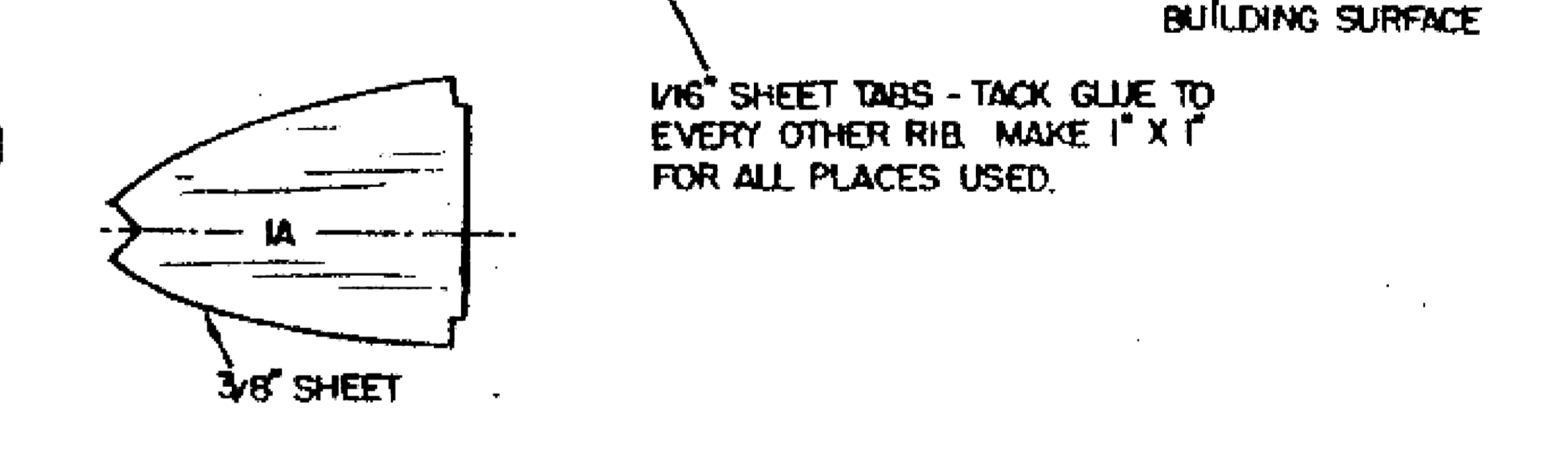
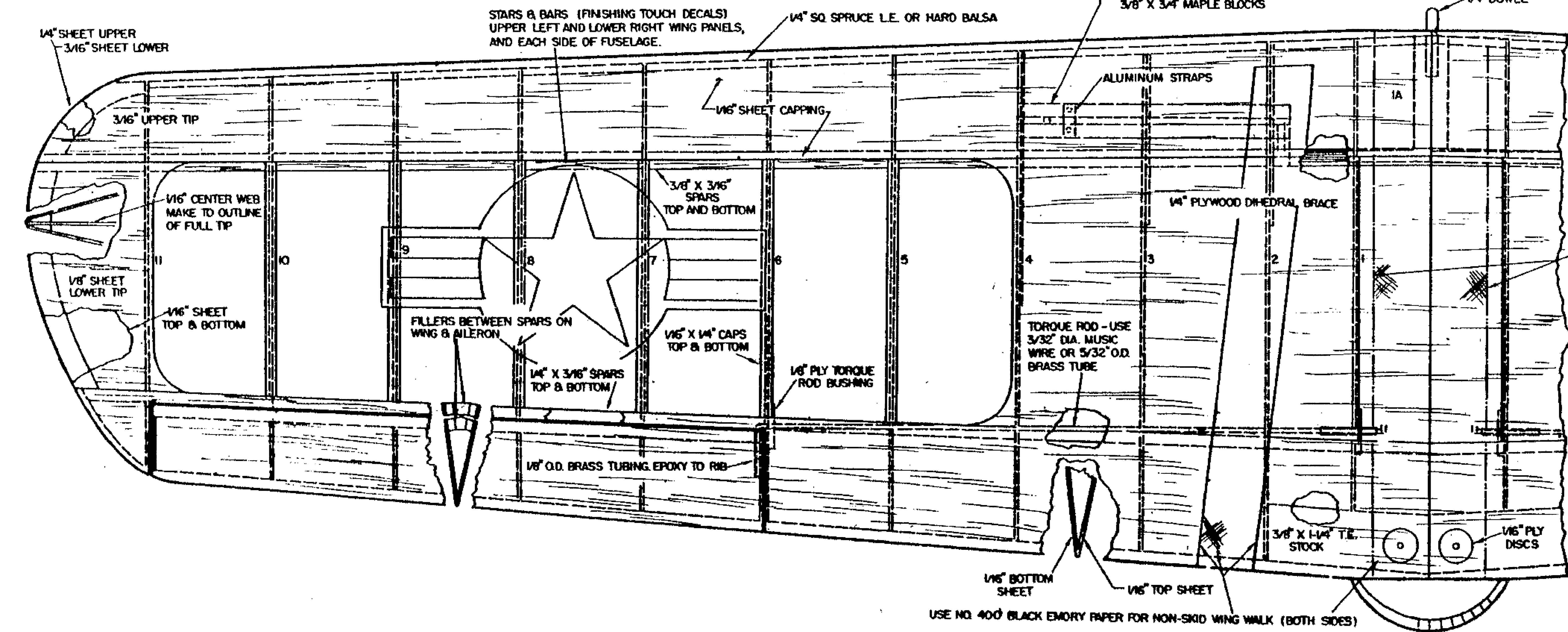
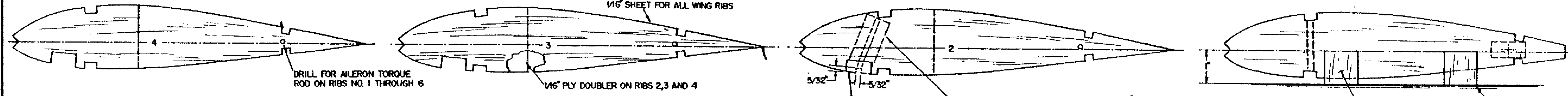
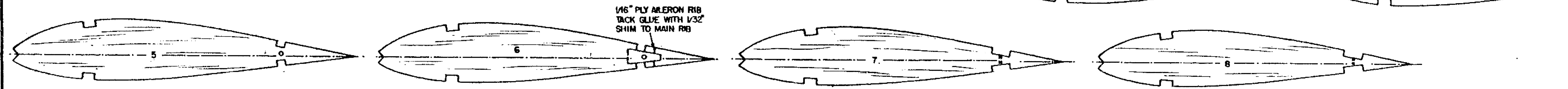
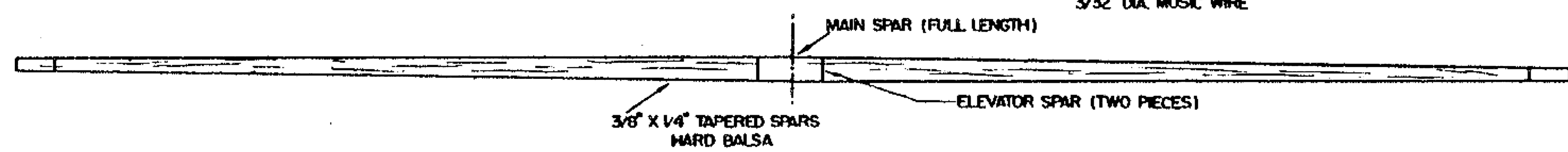
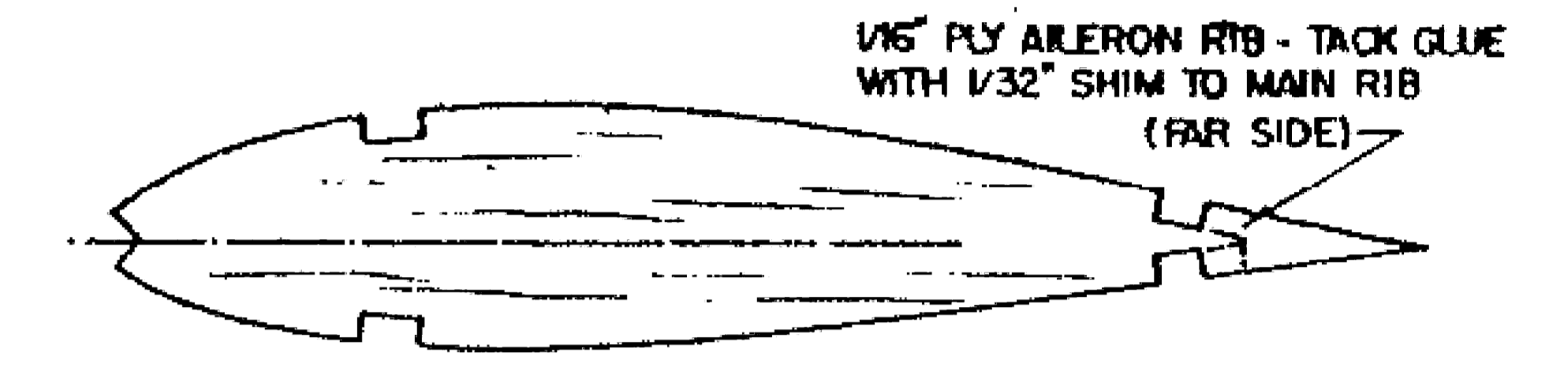
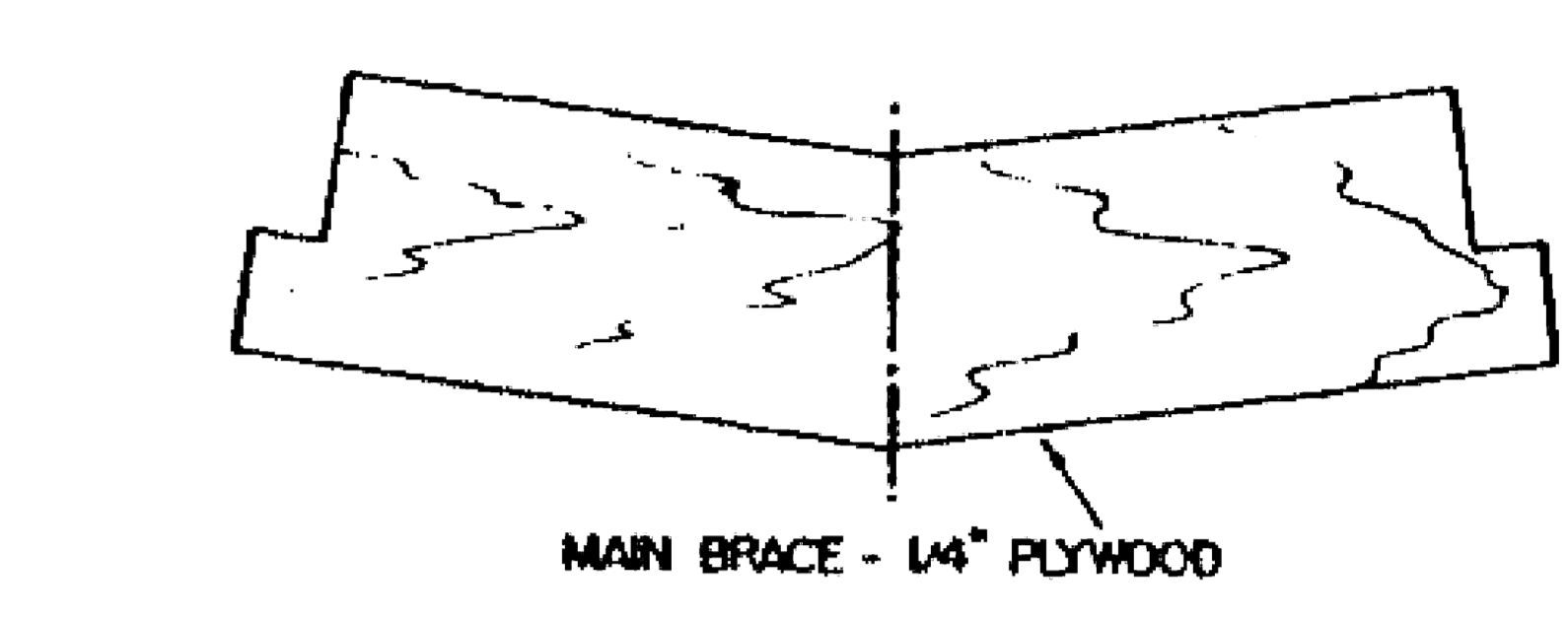
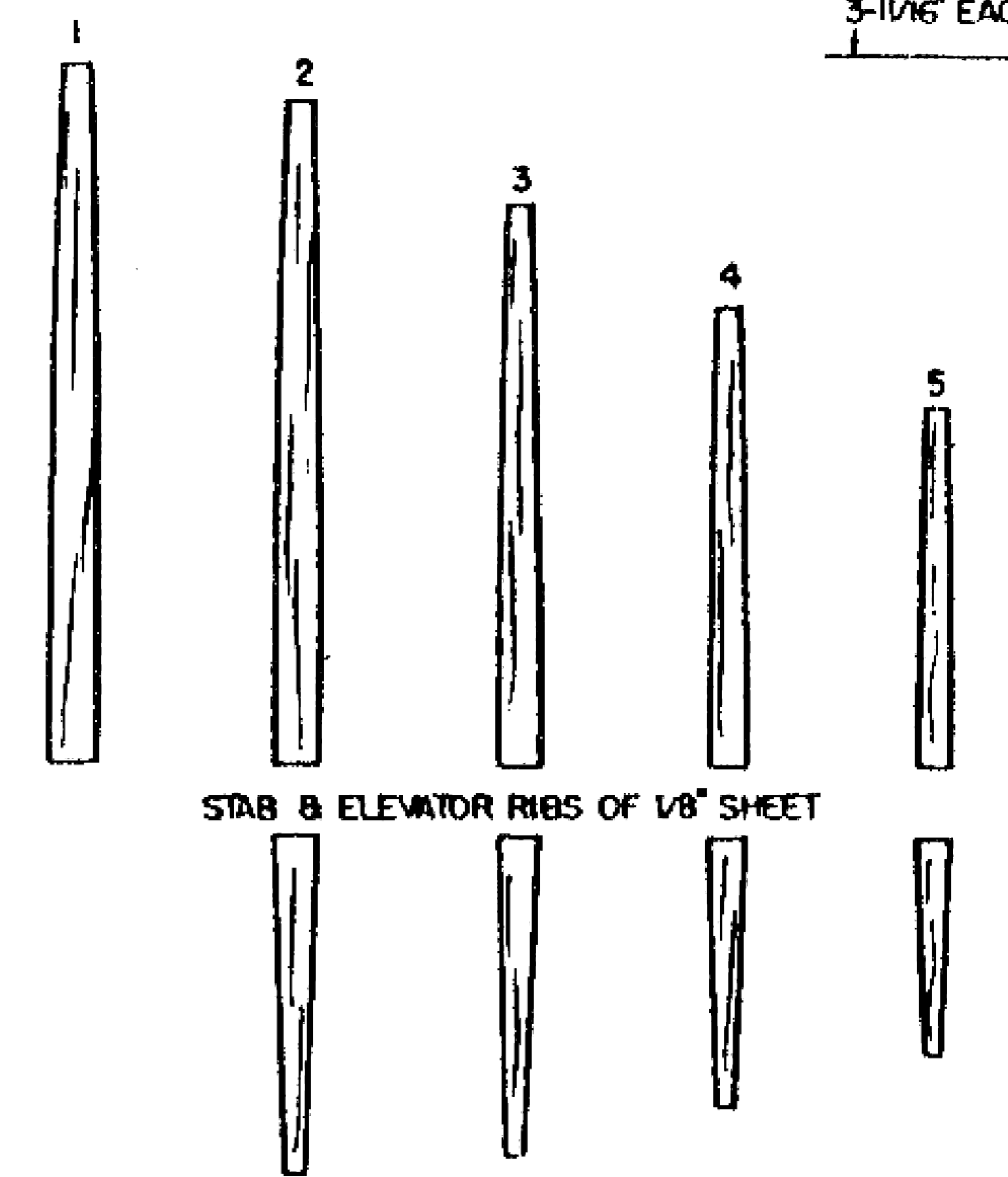
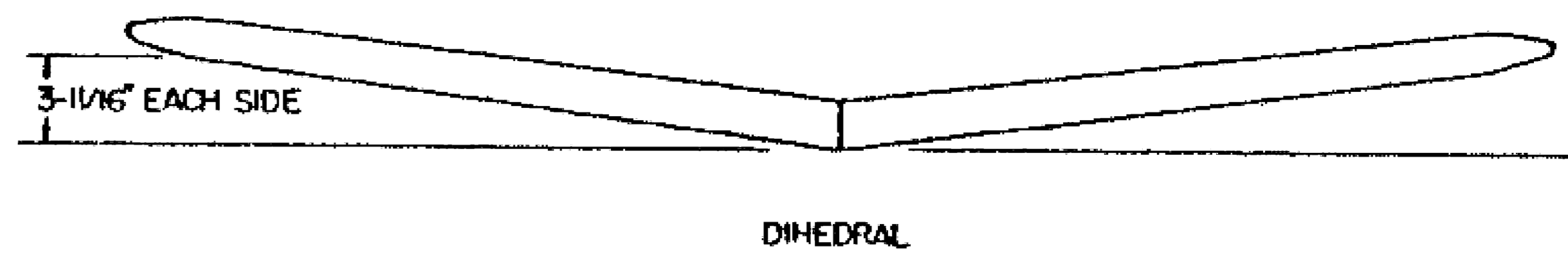
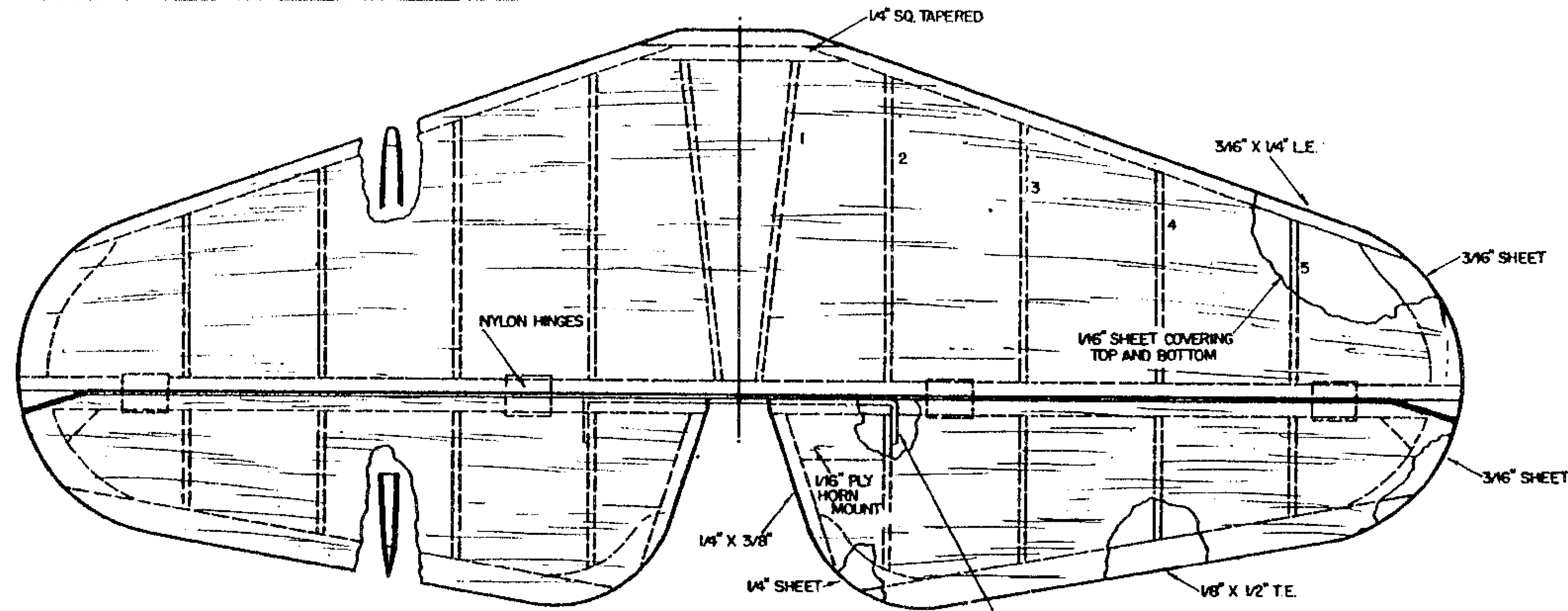

USE NO. 400 BLACK EMORY PAPER FOR NON-SKID WING WALK (BOTH SIDES)

DESIGNED & DRAWN BY GENE ROGERS