

SIG DURAL LANDING GEAR

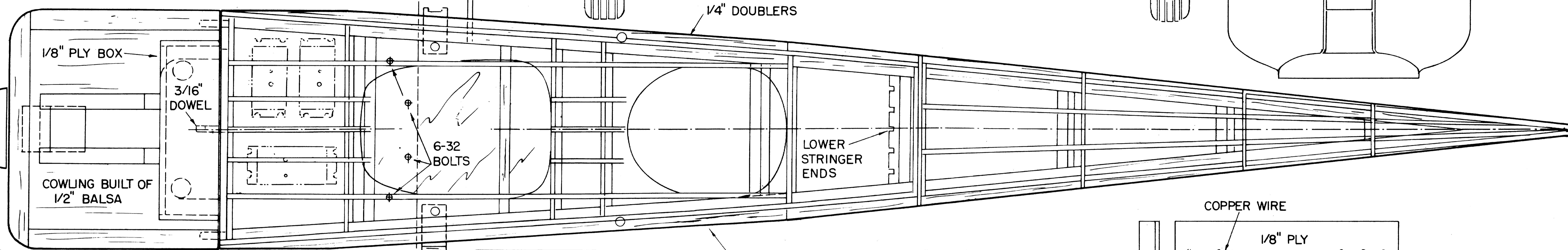
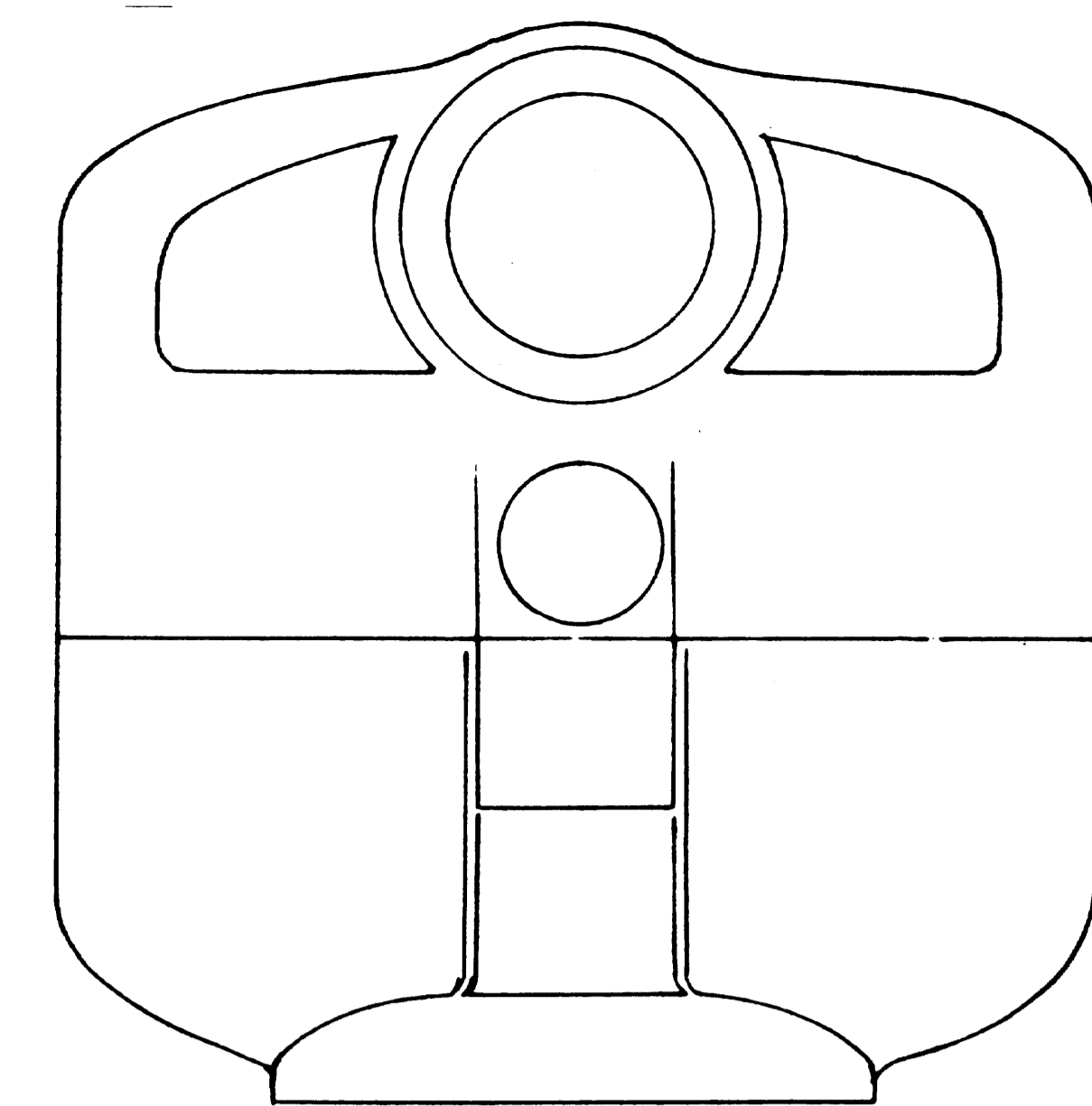
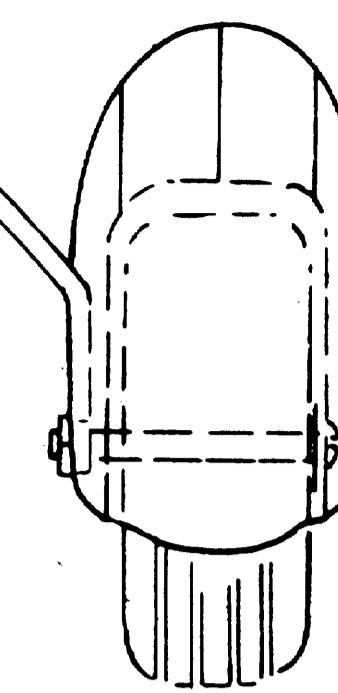

2" DIA. SPINNER

COWLING BUILT OF 1/2" Balsa

3/16" DOWEL

6-32 BOLTS

LOWER STRINGER ENDS

1/4" DOUBLERS

ALL FUSELAGE STRINGERS 1/8" X 1/2" Balsa  
FUSELAGE SIDING 1/8" Balsa

COPPER WIRE

1/8" PLY

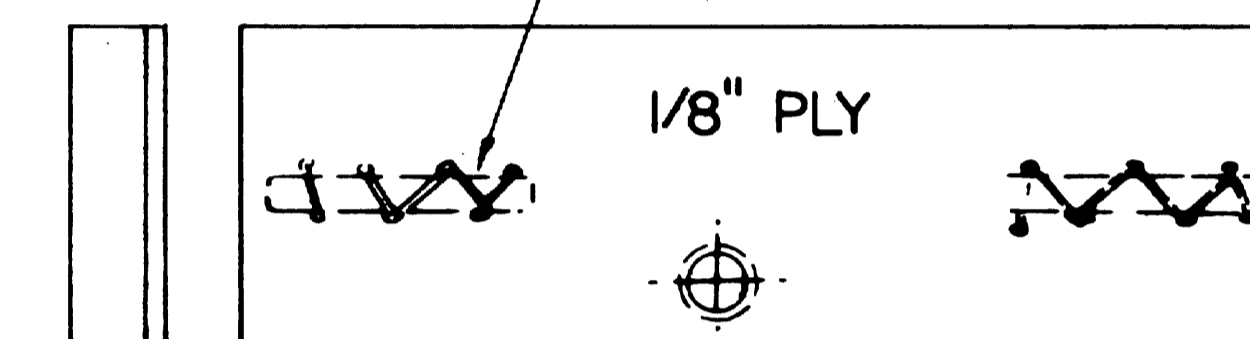

WING HOLD-DOWN - 2 REQ'D MOUNTS ON CABANE WIRES

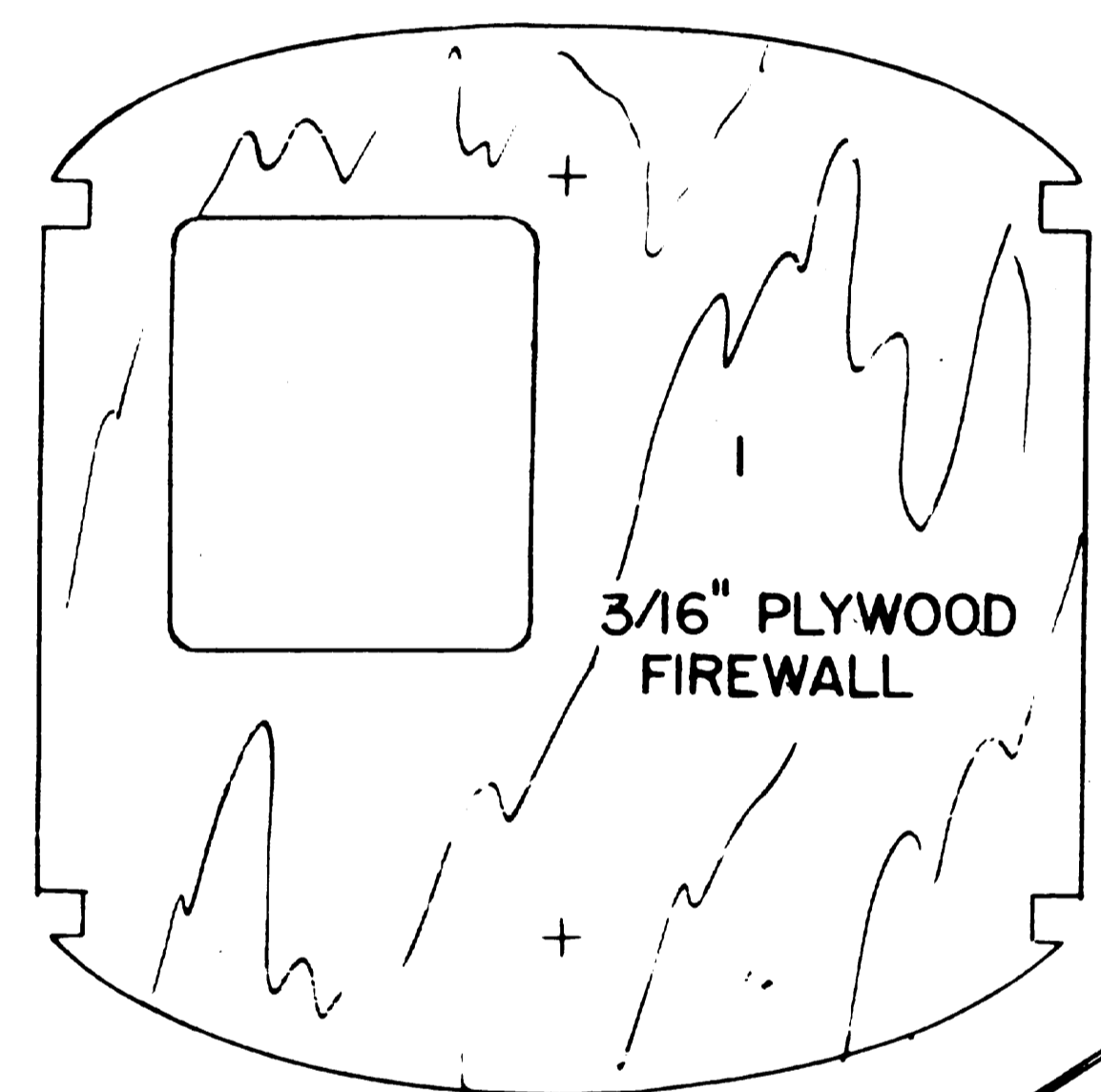

3/16" PLYWOOD FIREWALL

3/16" POSITIVE INCIDENCE IN WING

Balsa FILL

1/16" WIRE

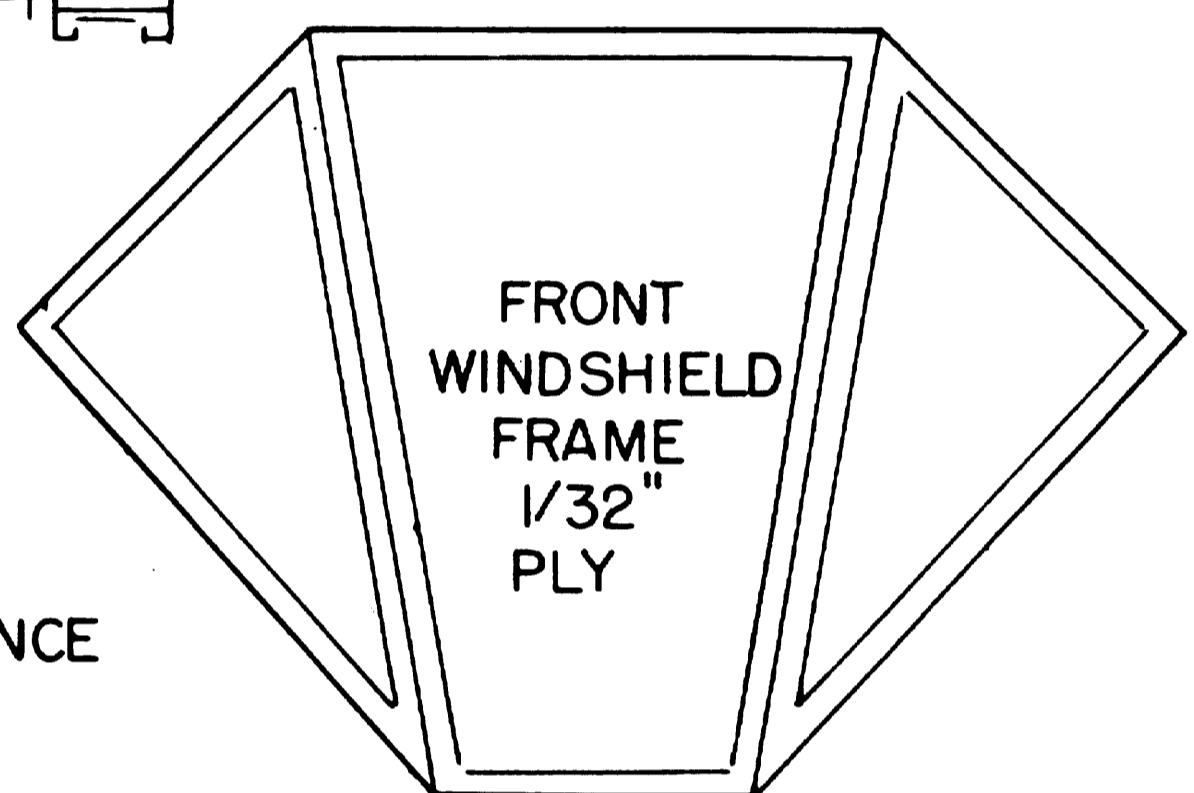

FRONT WINDSHIELD FRAME 1/32" PLY

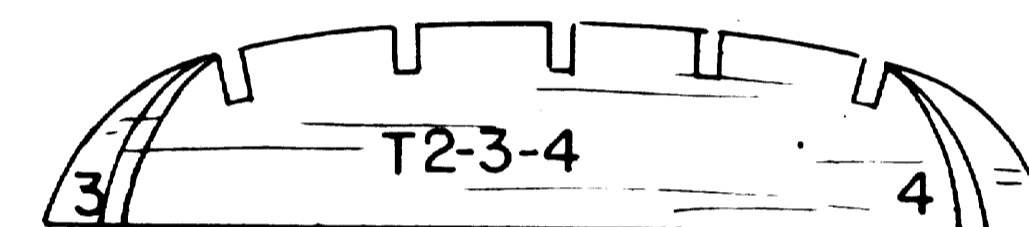
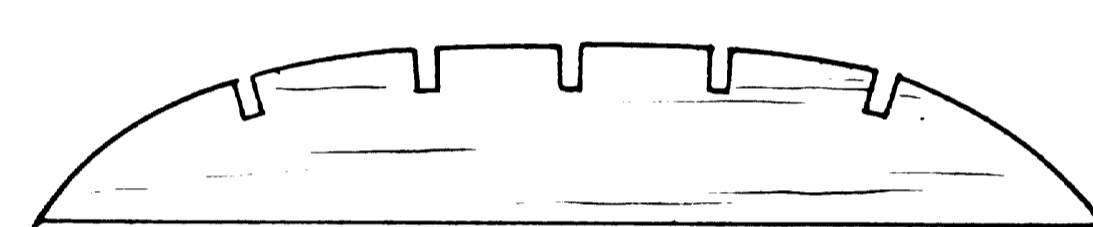

3/32" Balsa

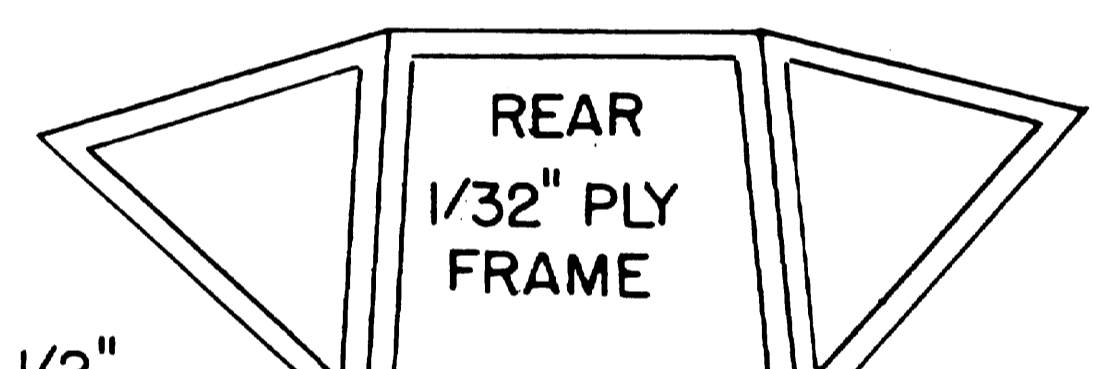
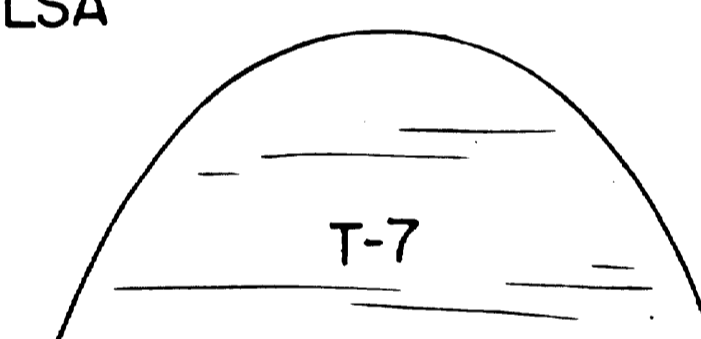
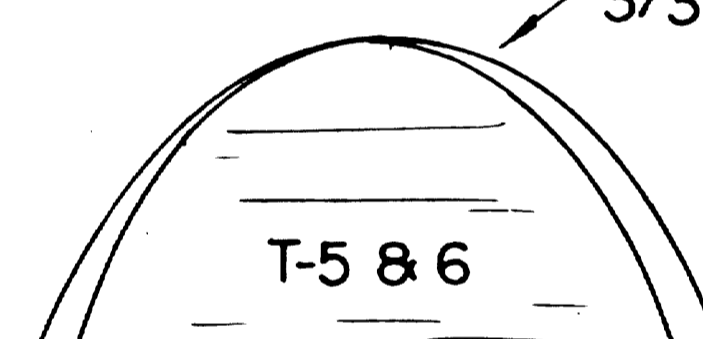

REAR 1/32" PLY FRAME

1/8" X 3/8" PLANKING TOP AND BOTTOM

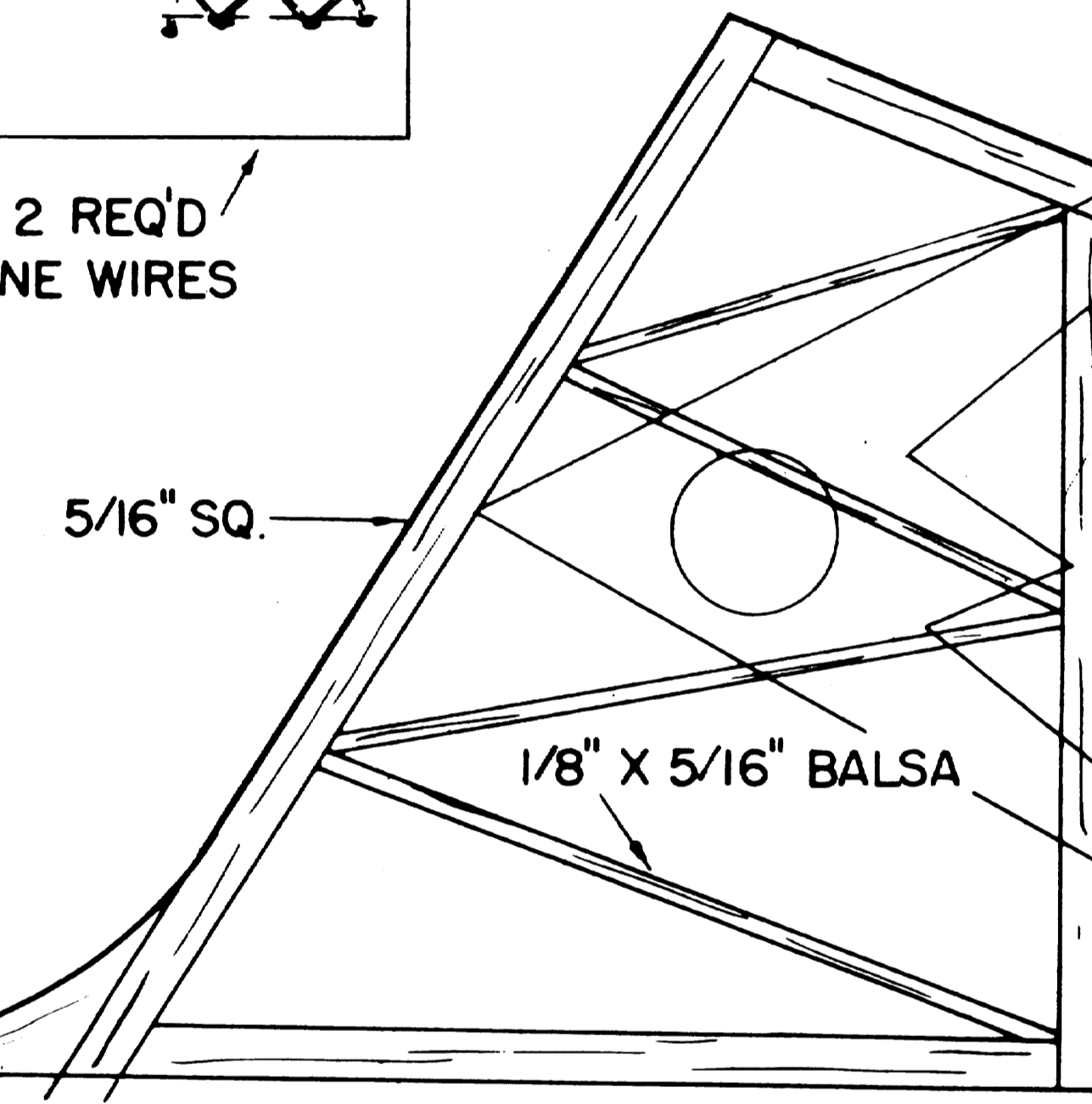

5/16" SQ.

1/8" X 5/16" Balsa

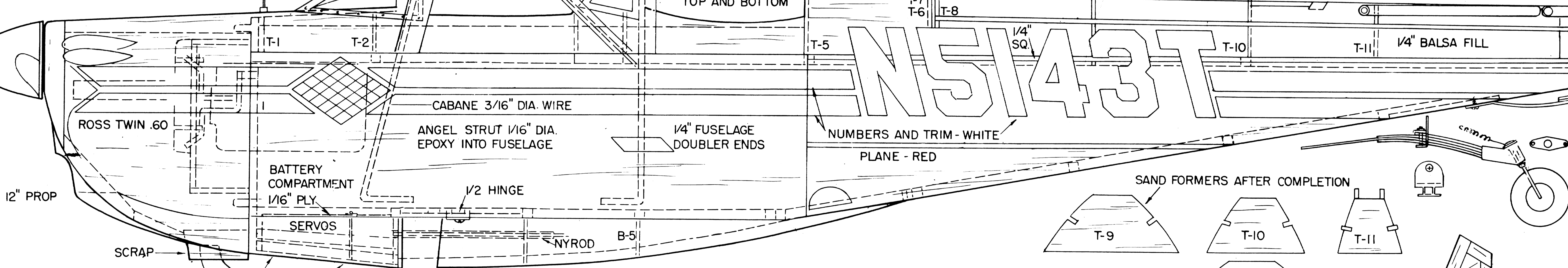

ROSS TWIN .60

12" PROP

SCRAP

EXHAUST 1/2" STOCK

BATTERY COMPARTMENT 1/16" PLY

SERVOS

1/8" X 3/8"

REMOVABLE PLATE FOR RADIO ACCESS

CABANE 3/16" DIA. WIRE

ANGEL STRUT 1/16" DIA. EPOXY INTO FUSELAGE

1/2 HINGE

1/4" FUSELAGE DOUBLER ENDS

NYROD B-5

NS143T

NUMBERS AND TRIM - WHITE  
PLANE - RED

T-7  
T-6  
T-8

T-5

1/4" SQ.

T-10

T-11

1/4" Balsa FILL

SAND FORMERS AFTER COMPLETION

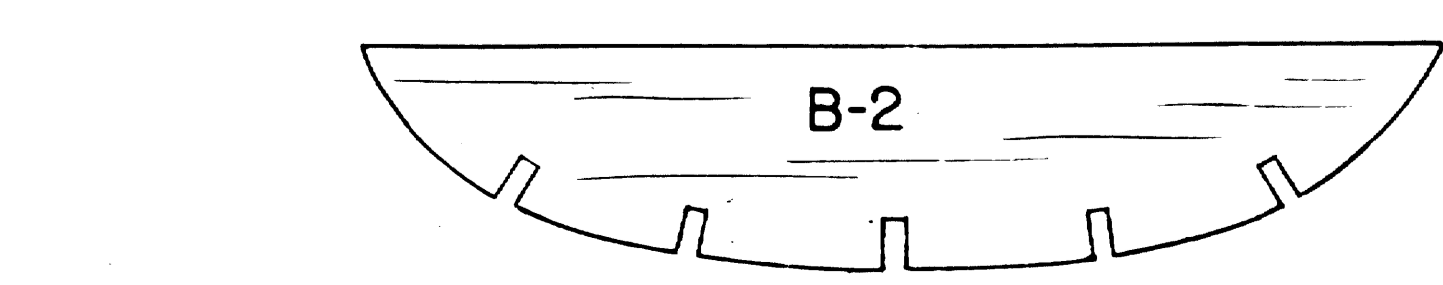
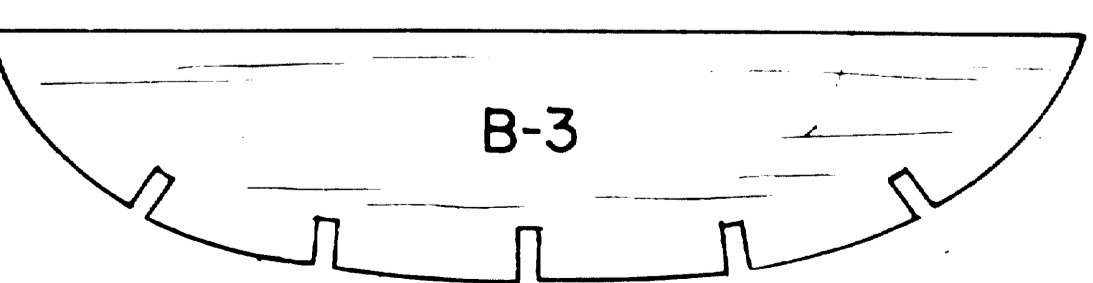
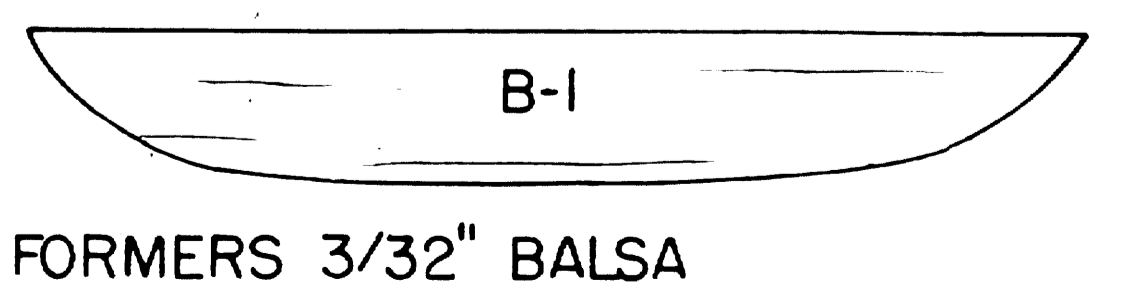
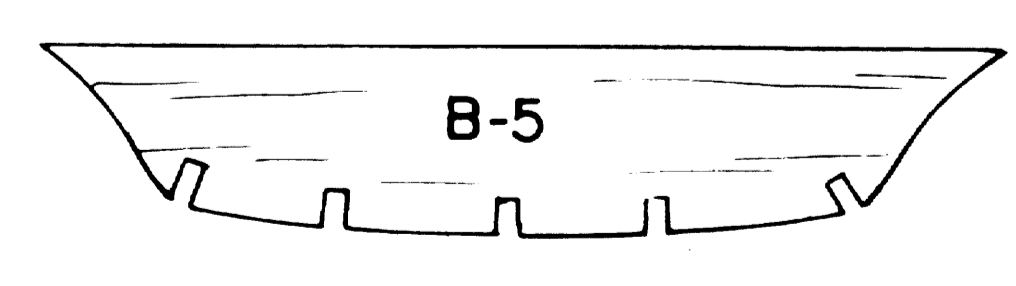
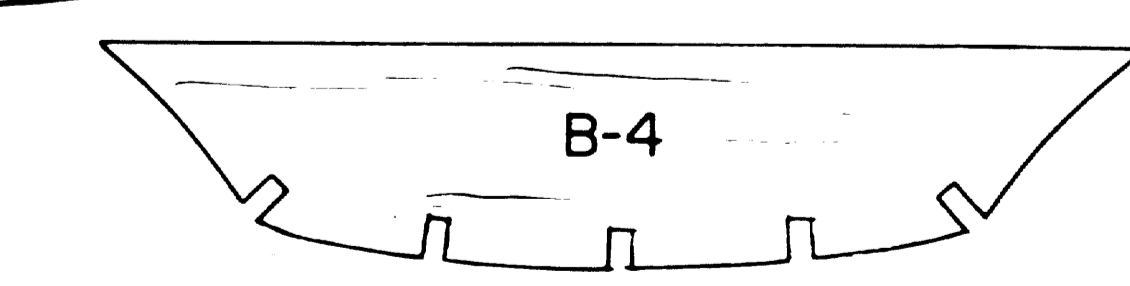
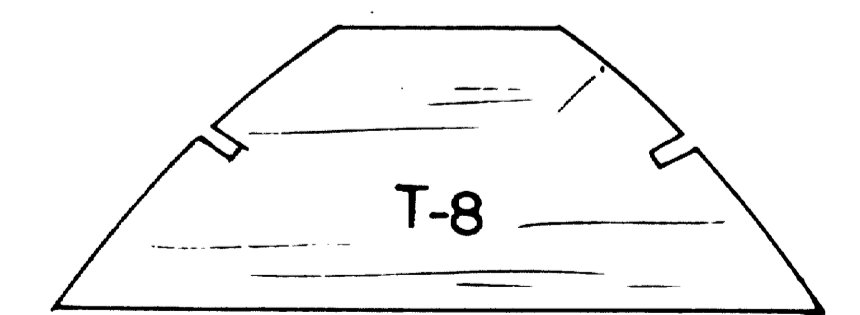
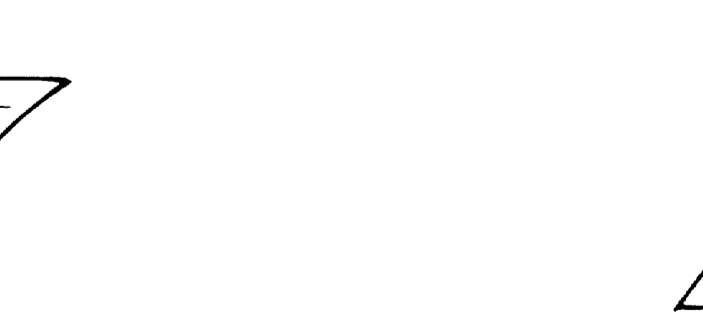
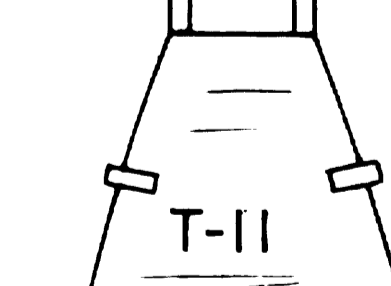
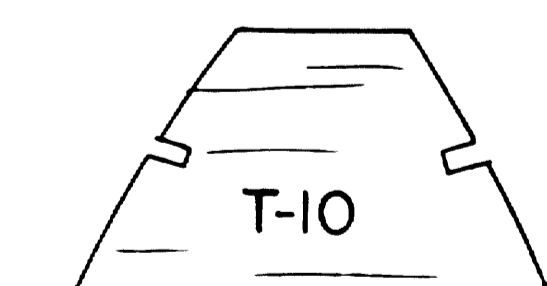
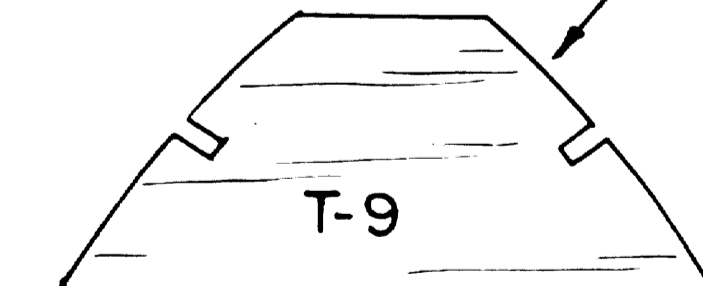

ALL FORMERS 3/32" Balsa

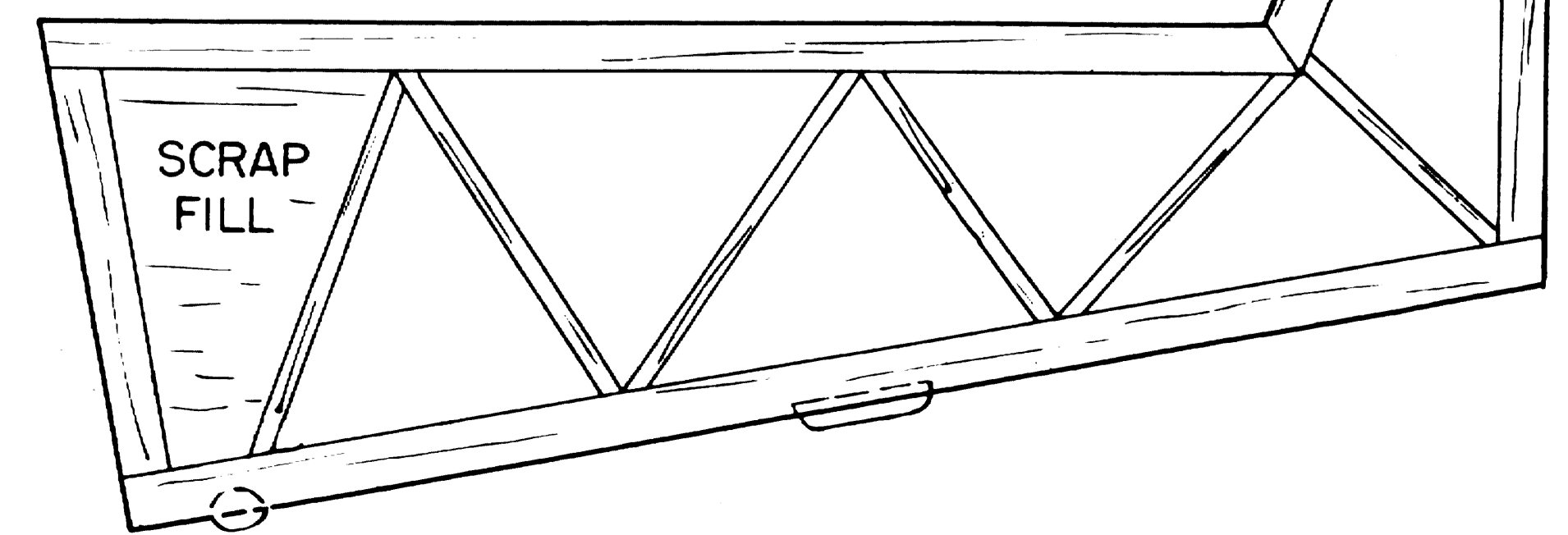

SCRAP FILL

