

WING CONSTRUCTION

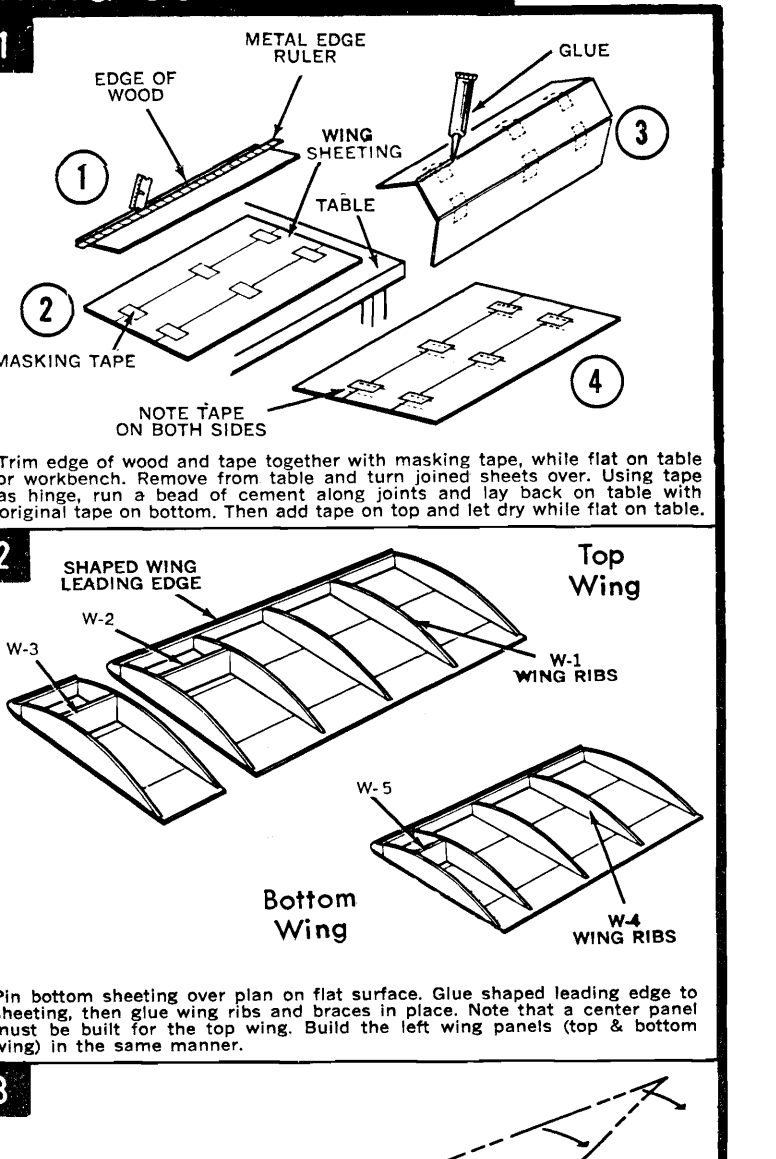

CONVERSION FOR HIGH-WING FLYING

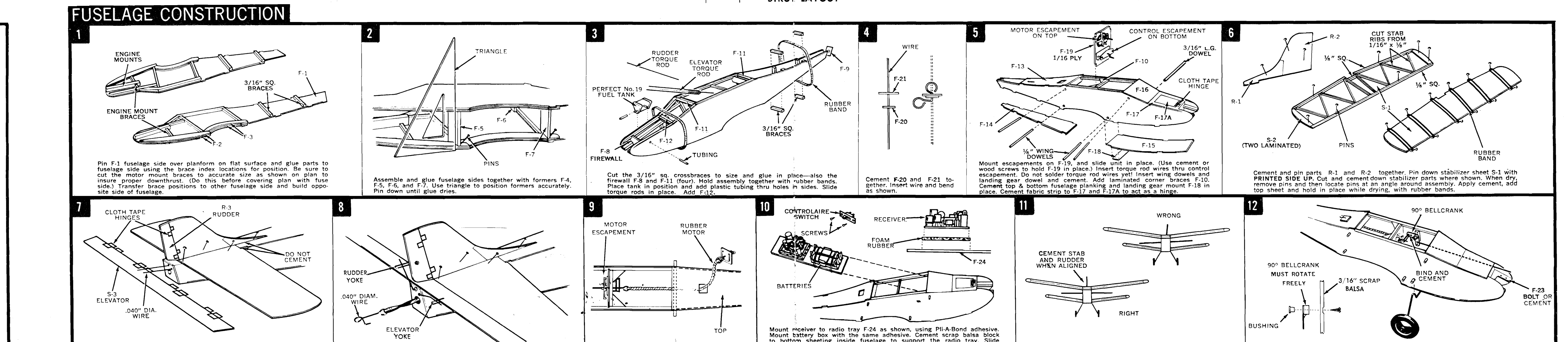
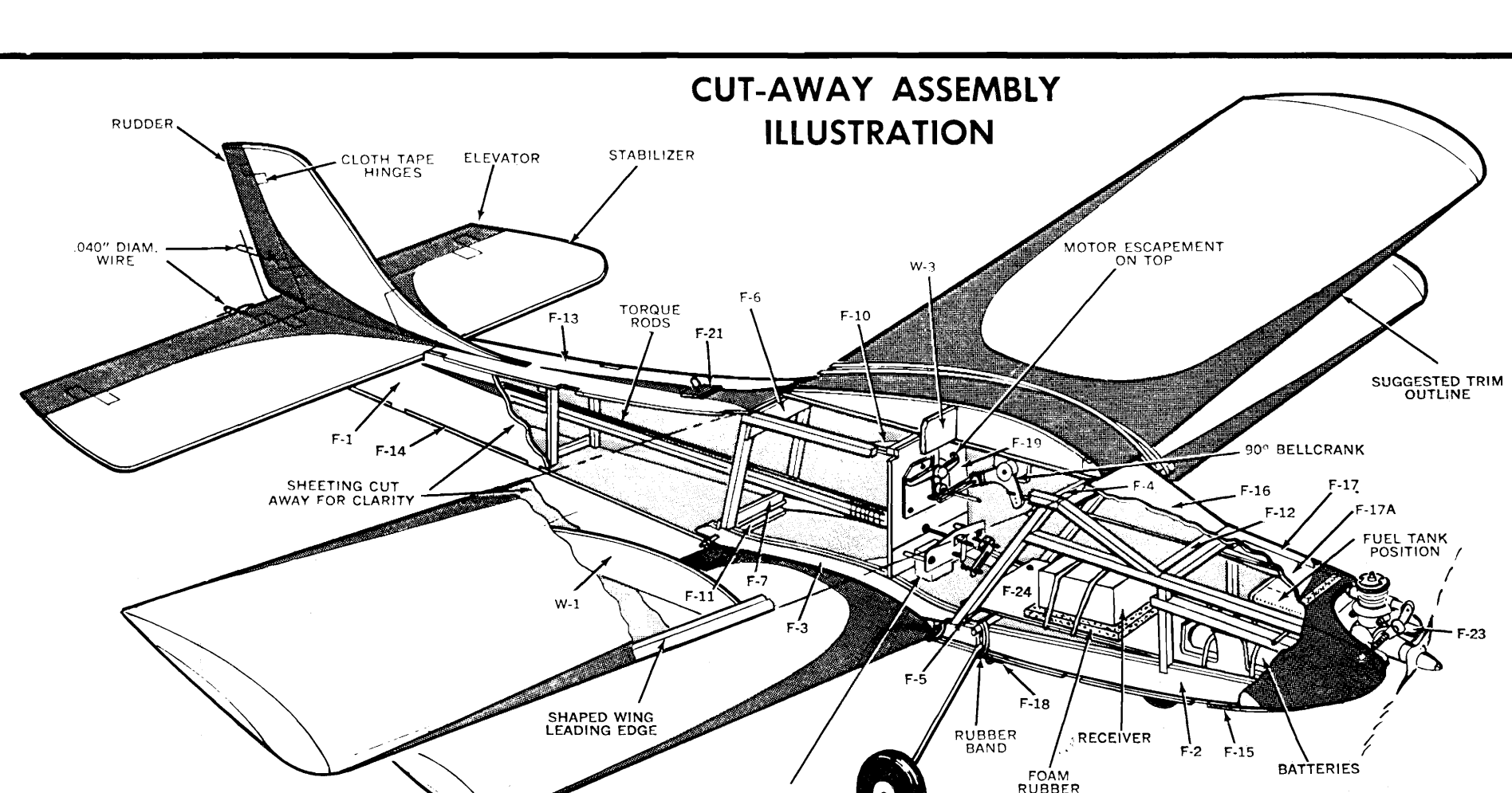
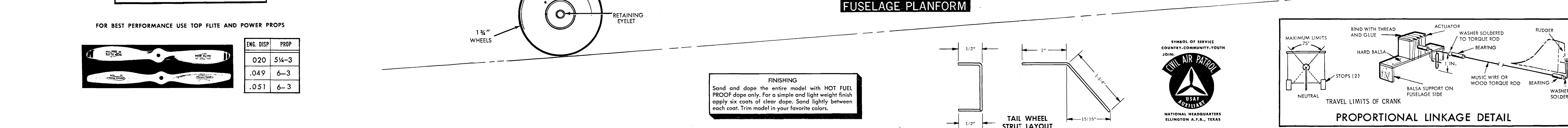
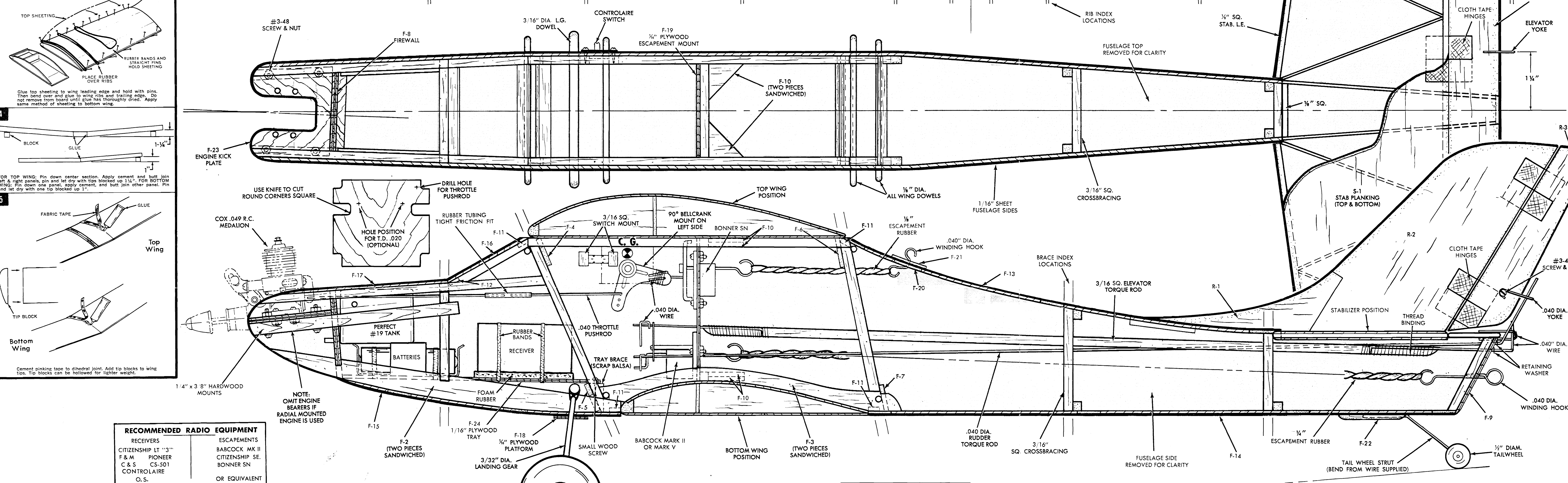
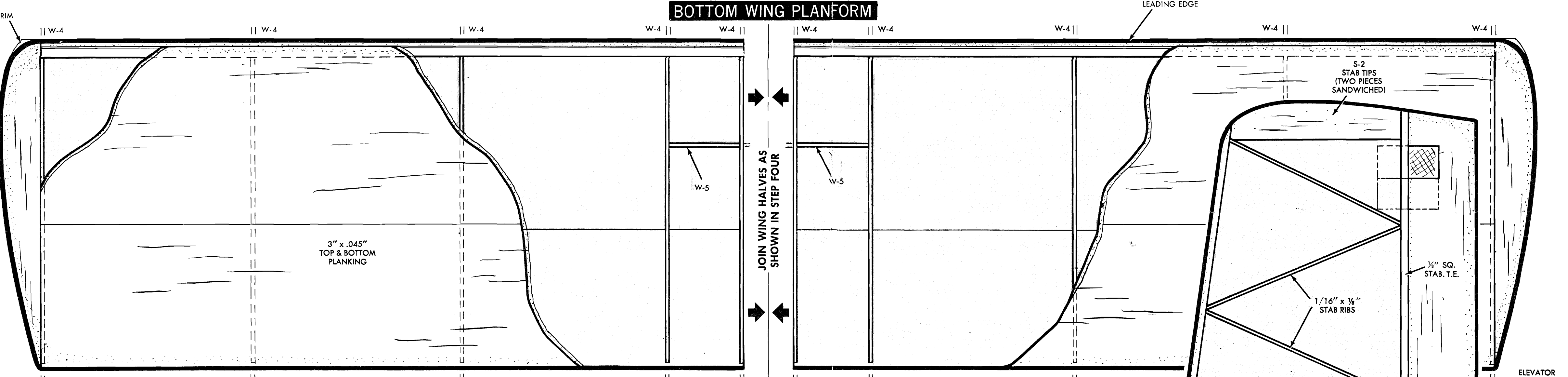
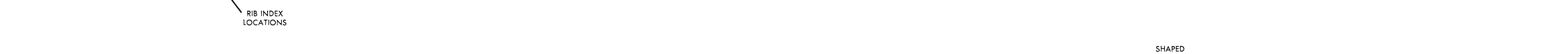
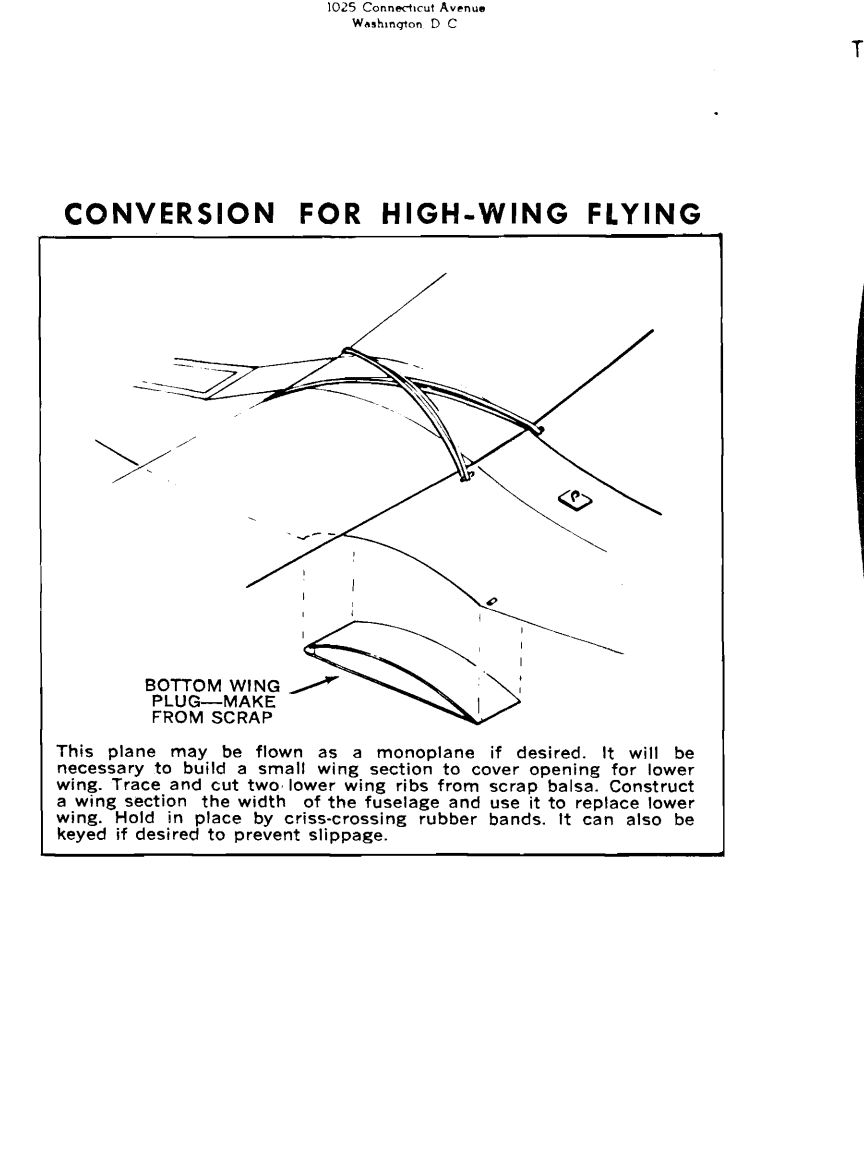

PRE-FLIGHT EQUIPMENT CHECKOUT FOR R/C COMPARACTS
Before flying your Top Flite R/C model, there are certain things you can do to assure success. Here they are:
1. At home
a. Following the radio manufacturer's instructions, check your transmitter and receiver batteries under load, to be sure the voltages are at safe operating strength.

HOW TO FLY TOP FLITE'S R/C COMPARACTS
One of the best features of Top Flite's small radio models is that, in addition to their ease of construction, they are easy to fly. If you go about it the right way, you can fly them with the same ease as you would a full-size model.
The small R/C model, weighing from 12 to 20 ounces, can be handled just like the full-size model. It is not too heavy to hold, and it is not too large to maneuver. It is also not too expensive to repair or replace.

STUNTS WITH TOP FLITE'S R/C COMPARACTS
Every R/C model pilot after he has learned the basic requirements of control - right turn, left turn, turning out of a stall, etc. - wants to do a little barrel roll and a few fancy stunts.
First, let's assume you are using a compound escapement - one command and hold gives right rudder, two commands and hold gives left rudder. This is the most common type of escapement used on R/C models.

LANDINGS
In the beginning the novice may find that landings occur rather far away from the transmitter. In time you will learn always to position the model in the air with respect to an intended landing spot so that regardless of the approach you can be recovered. A good way to do this is to land the model in a steep glide, with the wings level, and the rudder held in the position that will allow the model to be recovered in a steep glide.
Practice your timing and safety soon you'll be flying with the best of them!

TOP FLITE "Schoolgirl" 1/2A RC BIPLANE
DESIGNED FOR SINGLE CHANNEL USING THROTTLE, RUDDER AND ELEVATOR CONTROL...
Wing Area: 336 Sq. In.
Span: 32 1/4" x 24 1/4"
Length: 30"
Engine: .020 to .049
Designed By: Ken Willard
Produced By: Sid Axtell
Drawn & Illustrated By: J. W. Johnson
Professional Design: Jim Davis

Vertical text on the right edge of the page, likely a page number or reference code.