

FUSELAGE TOP VIEW

THE 1/32" Balsa TOP AND BOTTOM SHEETING IS REMOVED FOR CLARITY.

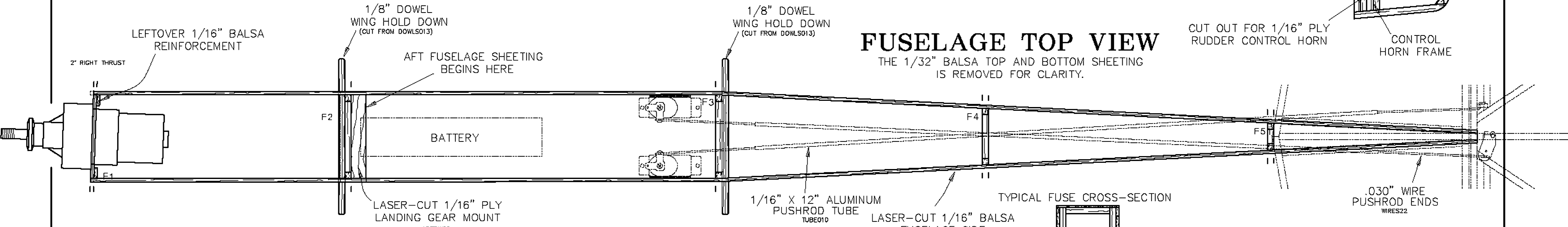

FUSELAGE SIDE VIEW

THE 1/16" Balsa SHEETING ON BOTH SIDES IS REMOVED FOR CLARITY.

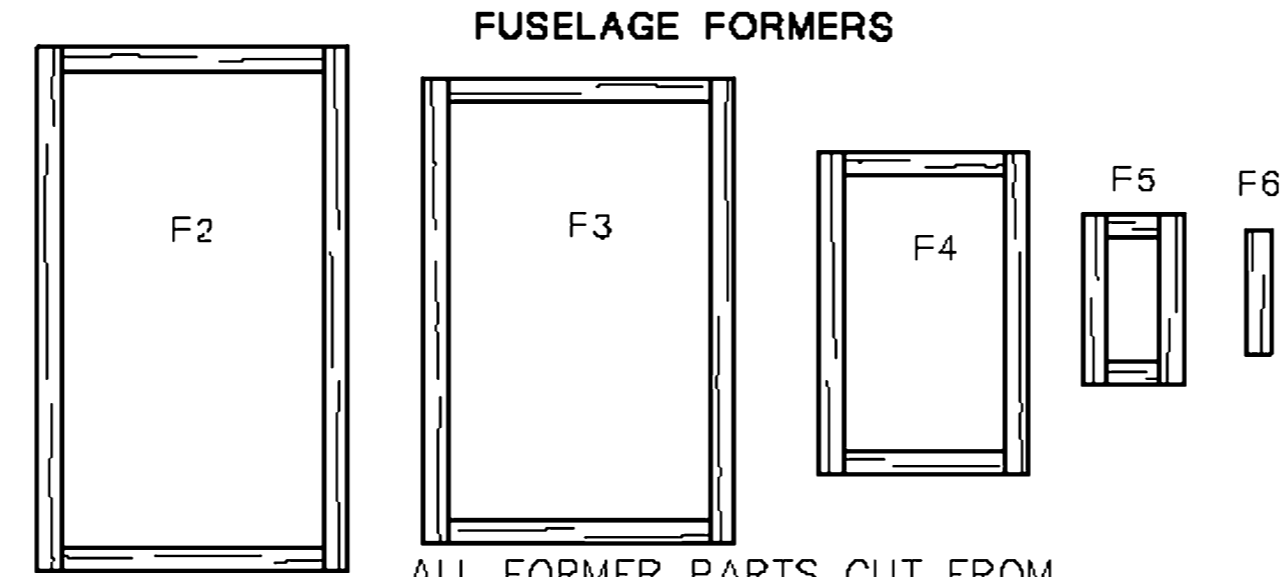
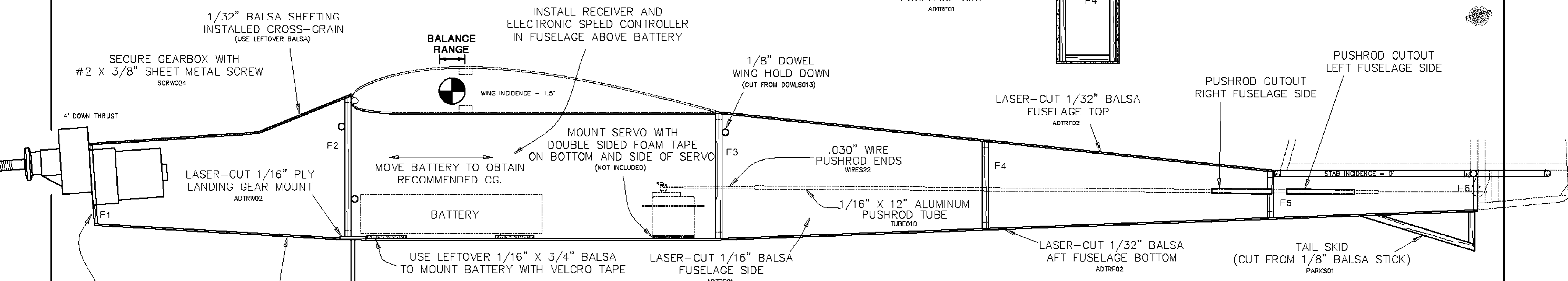

ALL COMMERCIAL RIGHTS RESERVED FUSELAGE PLAN NO: ADTRP02



DESIGNED BY: Ernest LeClair
 DRAWN BY: Ernest LeClair
 INSTRUCTIONS BY: Tim Lampe

QUESTIONS??
 e-mail us at
productsupport@greatplanes.com
 or call (217)398-8970
 Visit our Web Site at
www.greatplanes.com



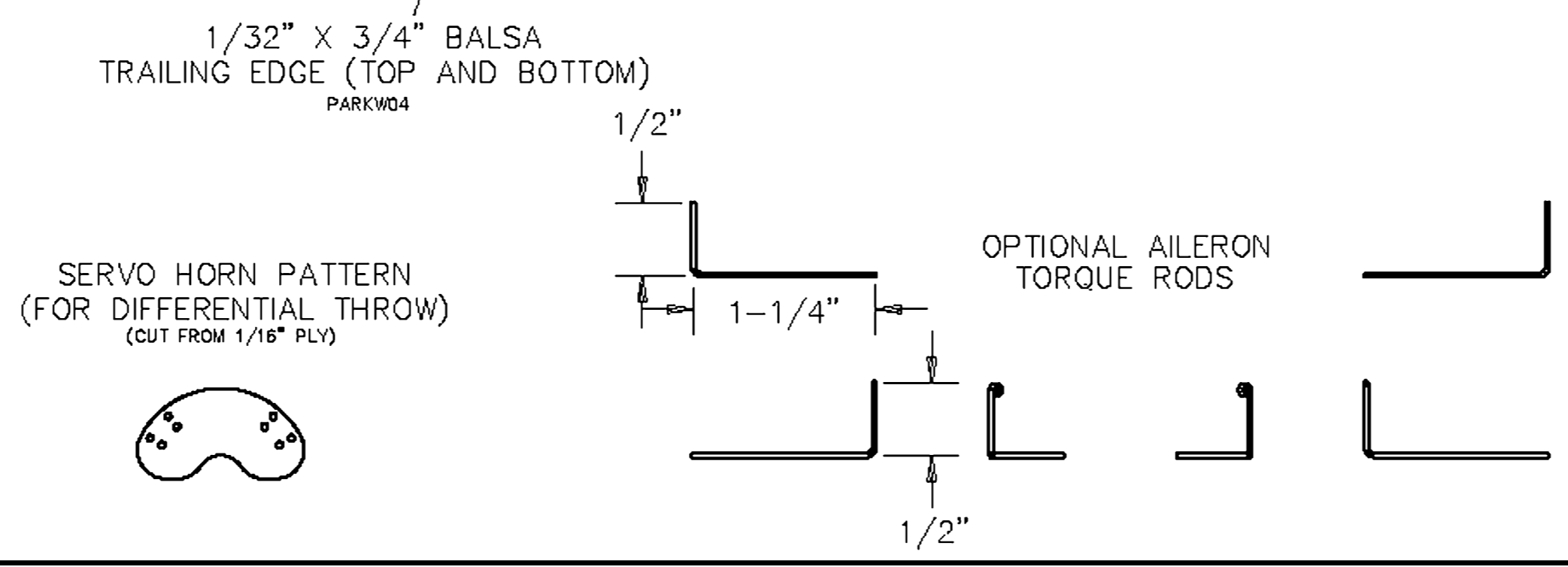
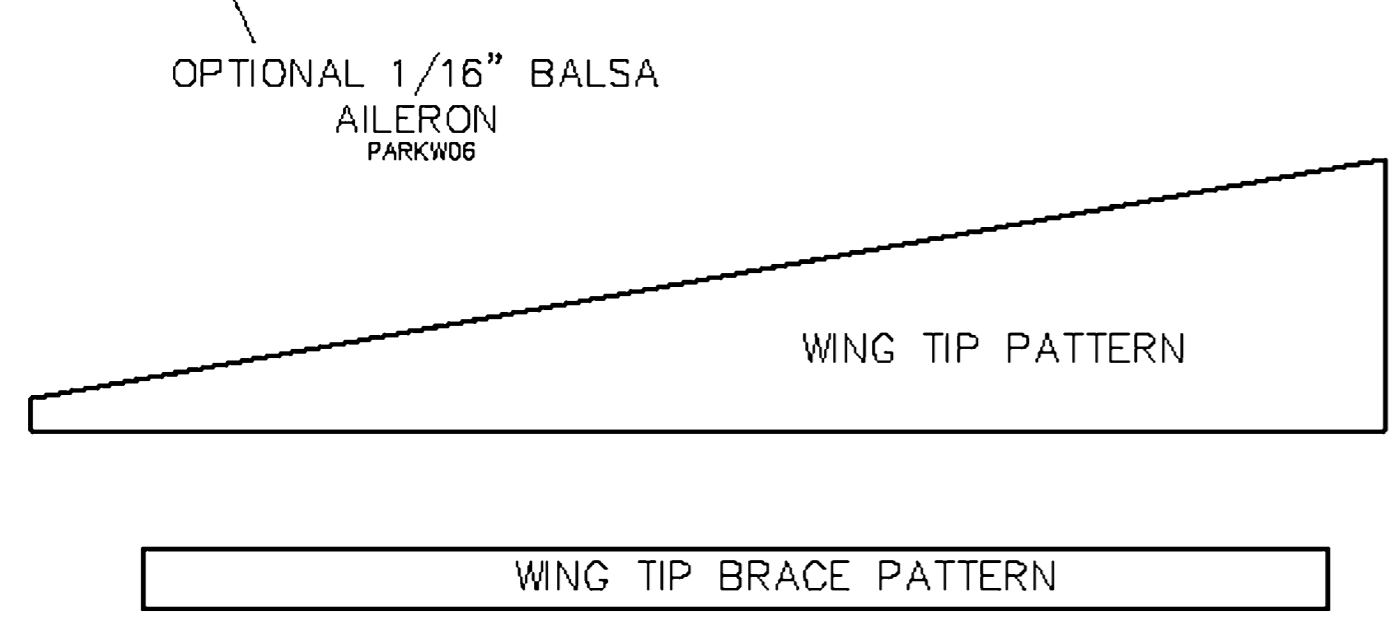
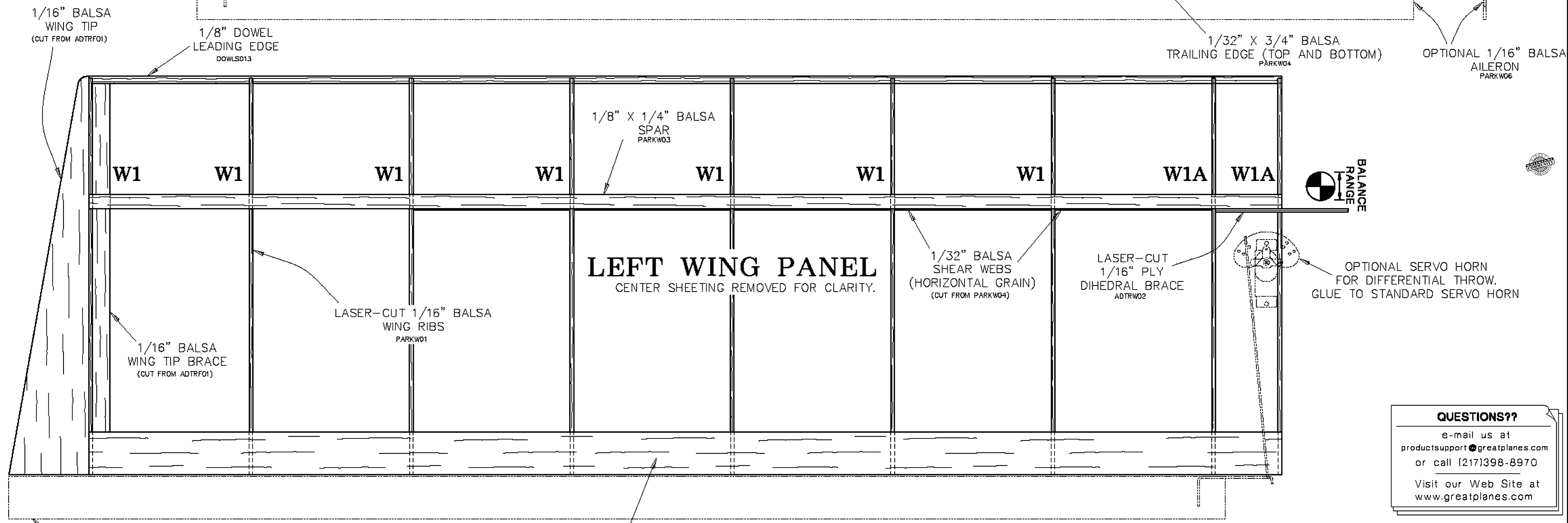
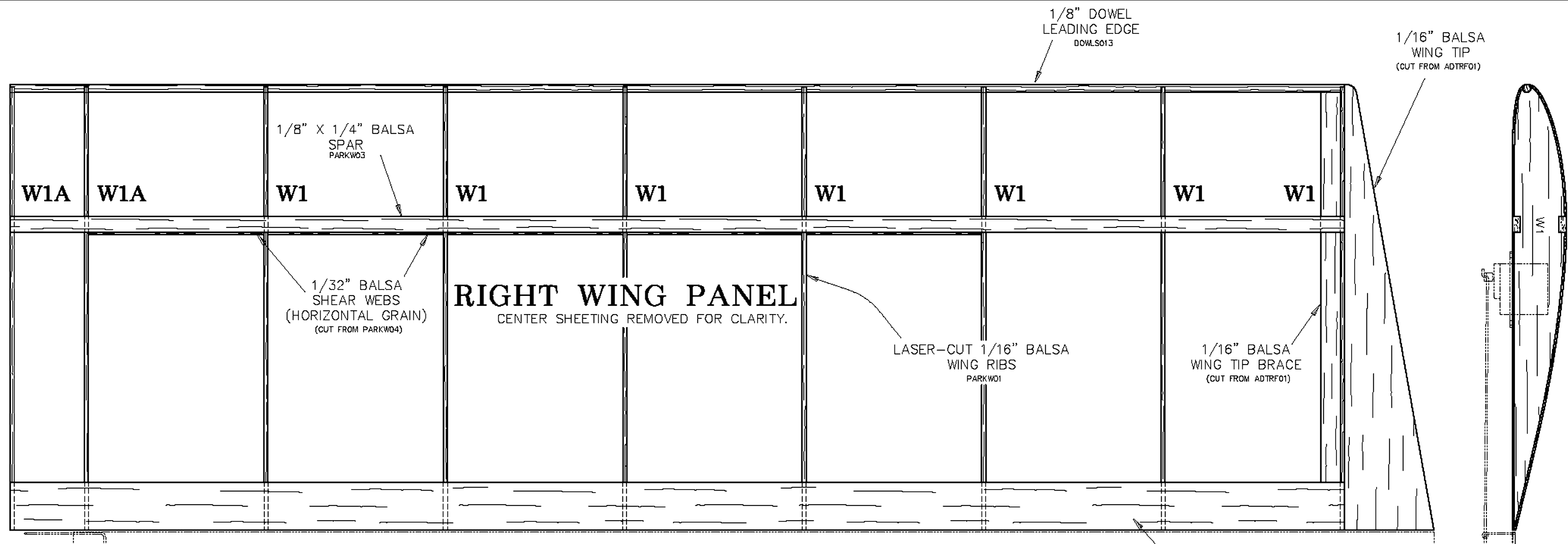

QUESTIONS??
 e-mail us at
 productsupport@greatplanes.com
 or call (217)398-8970
 Visit our Web Site at
 www.greatplanes.com

ALL COMMERCIAL RIGHTS RESERVED WING PLAN NO: ADTRP01

Tutor Trainer

DESIGNED AND DRAWN BY: Ernest LeClair
 INSTRUCTIONS BY: Tim Lampe

GREAT PLANES
 MODEL MANUFACTURING COMPANY

© 2000 P.O. Box 788 Urbana, Illinois 61803 (217) 398-8970