

FUSELAGE TOP VIEW
NOTE-ALL TOP FORMERS, STRINGERS AND SHEETING ARE OMITTED FOR CLARITY.

FUSELAGE SIDE VIEW
NOTE-ALL LEFT SIDE SHEETING IS OMITTED FOR CLARITY.

NOTE-ATTACH FOUR-CYCLE ENGINE MOUNT DIRECTLY TO FIREWALL. ENGINE SHOULD BE SIDE MOUNTED.

NOTE-ALL RAZOR CUT FORMERS ARE 3/32" Balsa

1/4" Balsa FIN AND RUDDER TIPS- MAKE FROM 1/4" X 3/4" X 20-3/4" Balsa. RUDDER BOTTOM IS MADE FROM THE SAME STOCK.

NYLON HORN ON RUDDER MUST GO OVER TAILWHEEL WIRE FOR Balsa SUPPORT

2 CYCLE ENGINE MOUNT AND ENGINE BOX

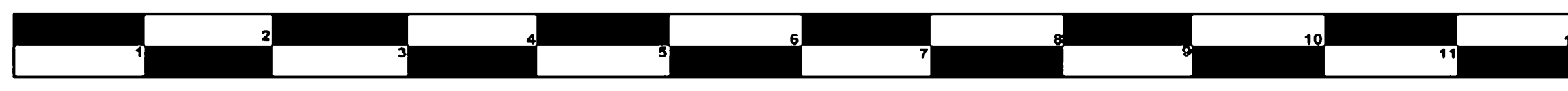

Use scale to check print size



WING TIP IS SHOWN SANDED WITH NO TOP SHEETING. SEE THE DRAWING BELOW FOR TOP SHEETING VIEW.

TOP WING C- ALL TOP SHEETING AND CAP STRIPS ARE OMITTED FOR CLARITY.

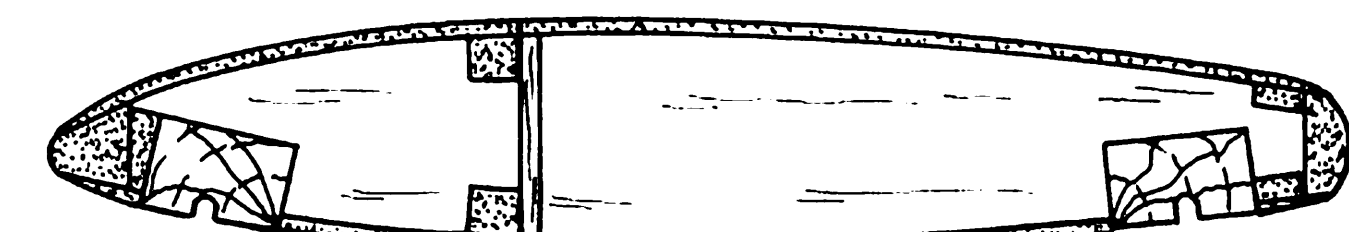

R2 RIB SECTION AT CENTER

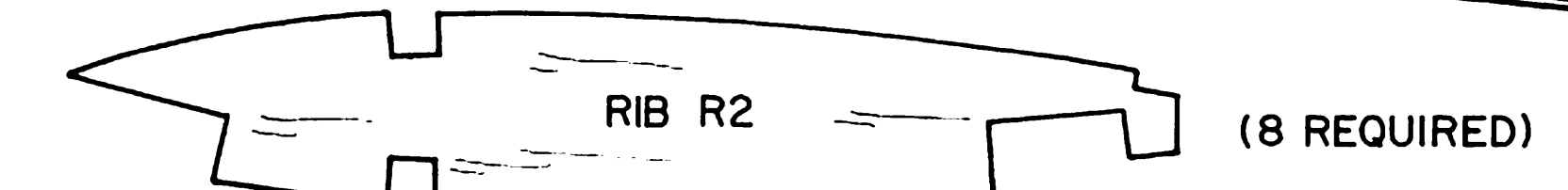

(8 REQUIRED)

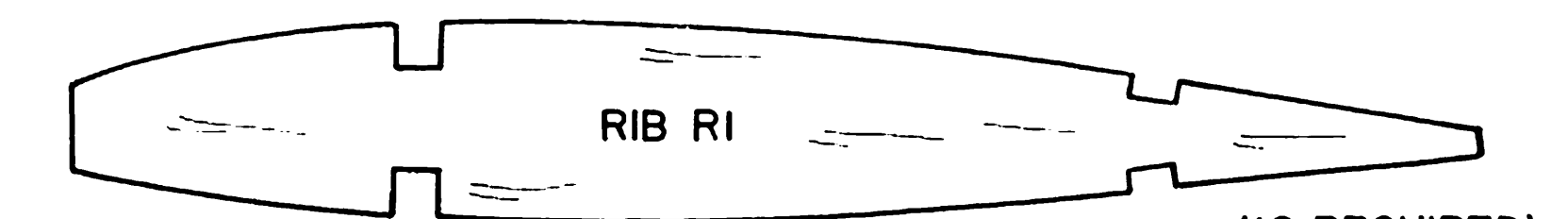

(16 REQUIRED)

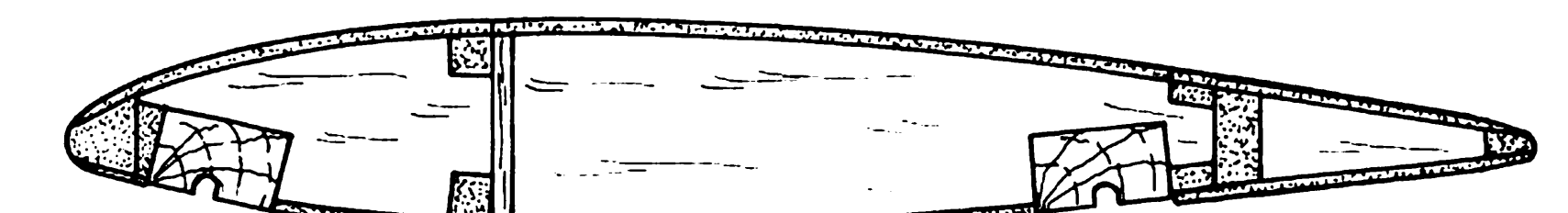

R2 RIB SECTION NEXT TO SCARF JOINT

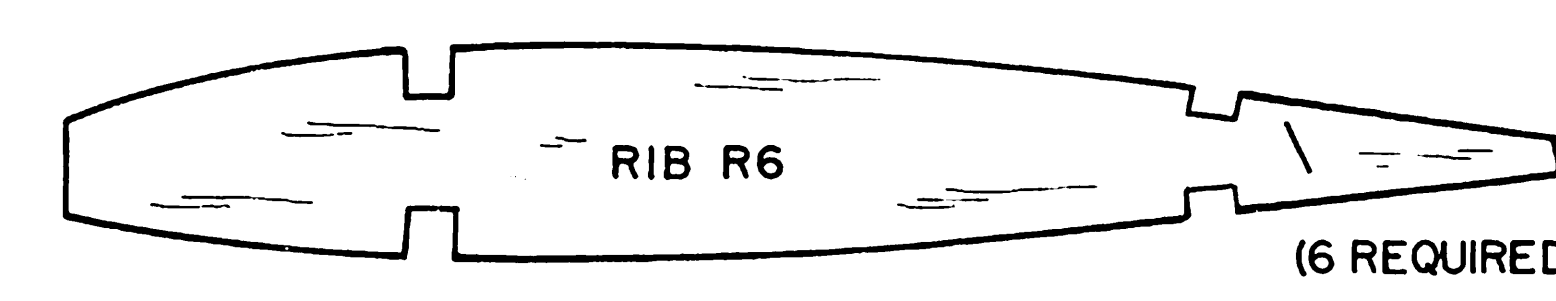

(6 REQUIRED)

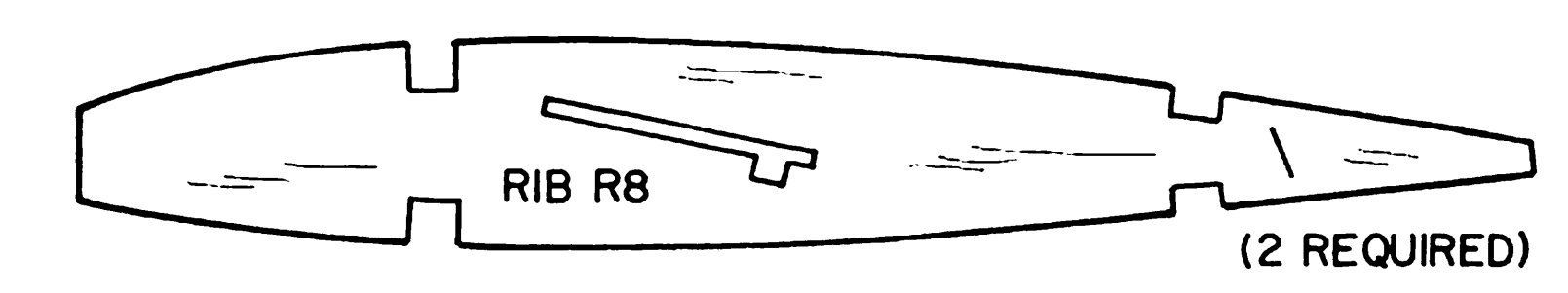

(2 REQUIRED)

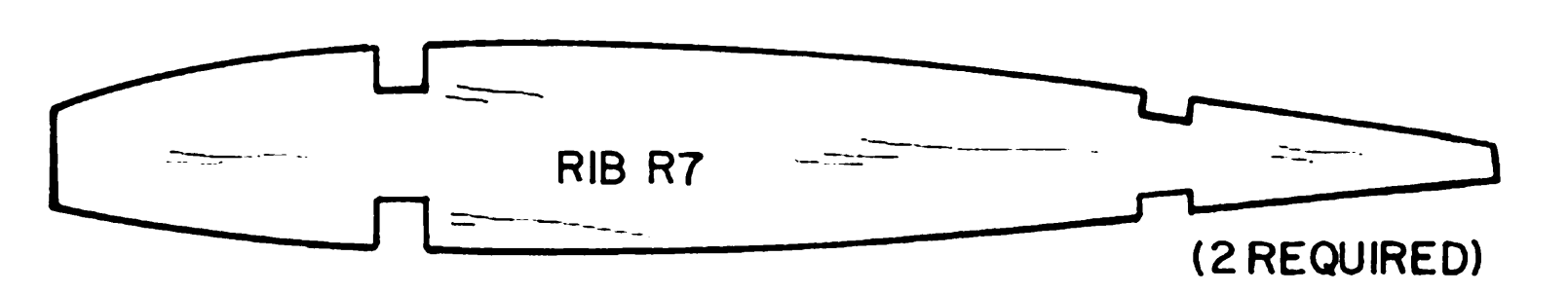

(2 REQUIRED)

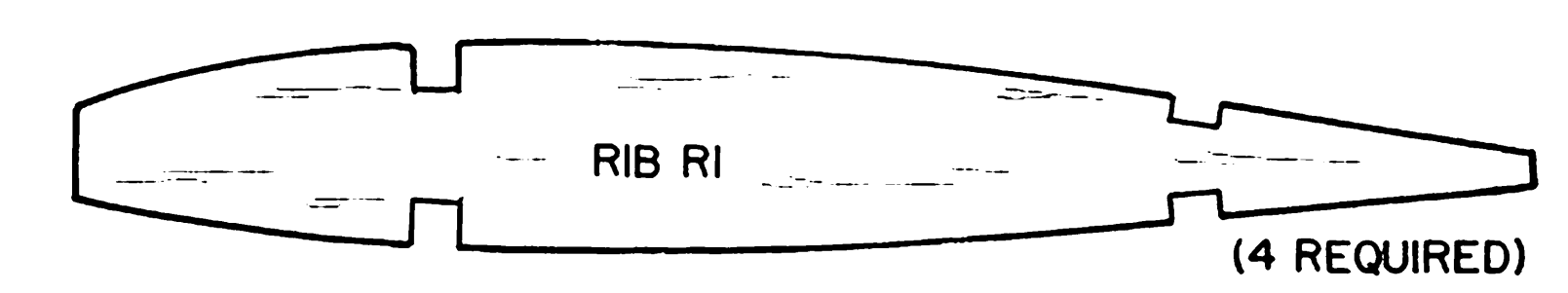

(4 REQUIRED)

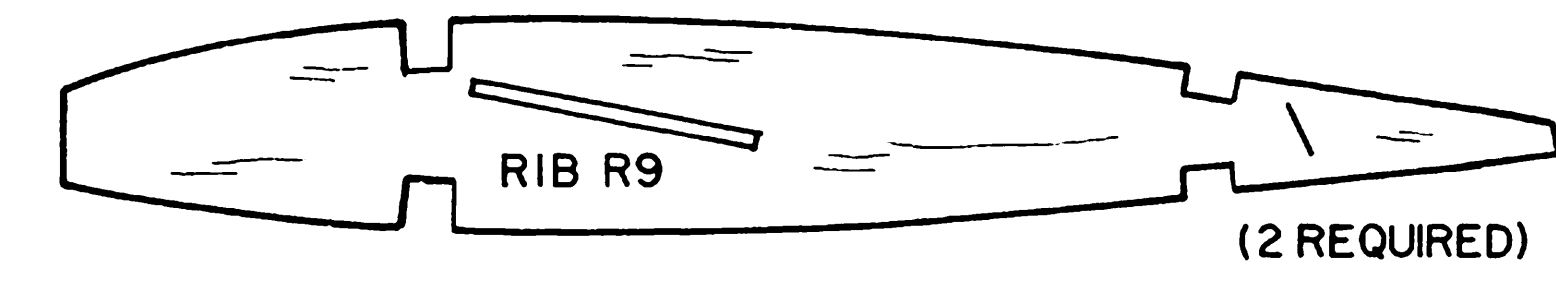

(2 REQUIRED)

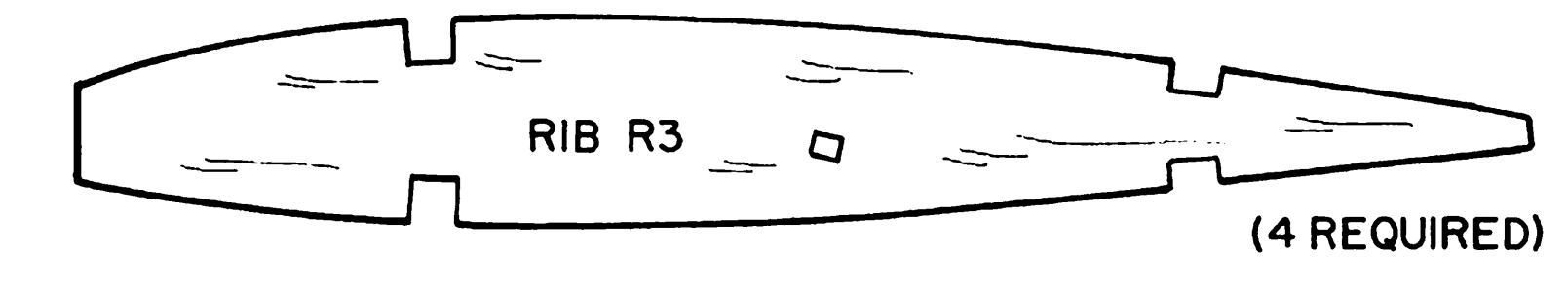

(4 REQUIRED)

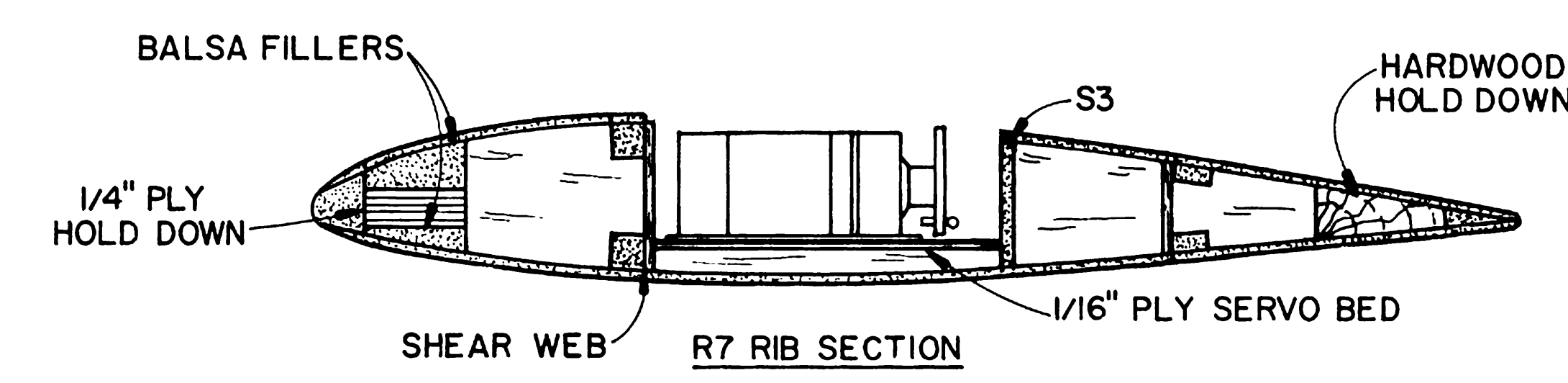

R7 RIB SECTION

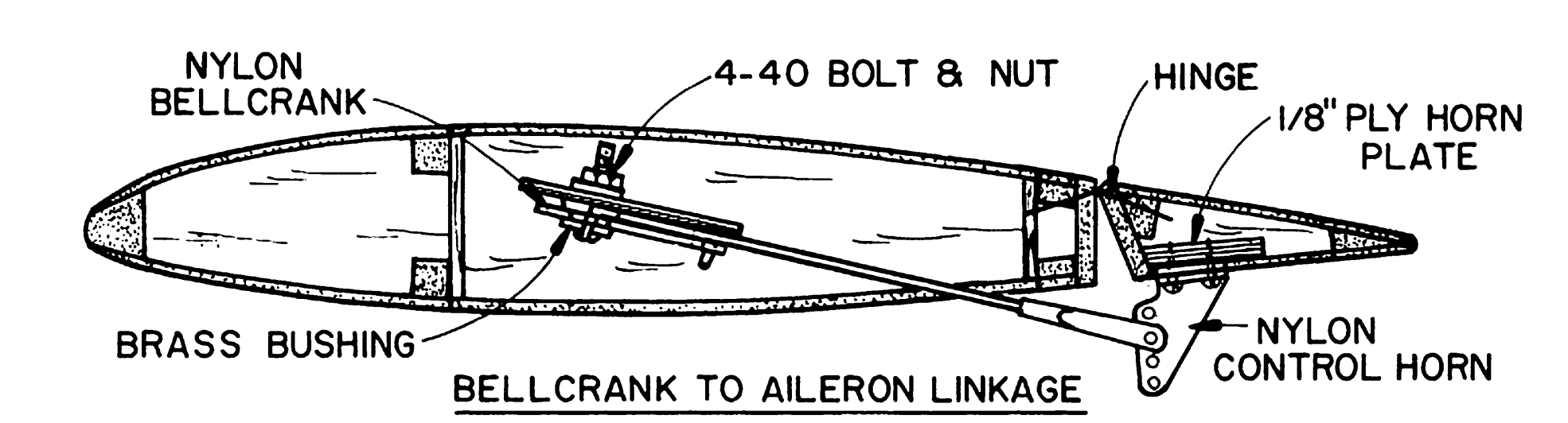

BELLCRANK TO AILERON LINKAGE

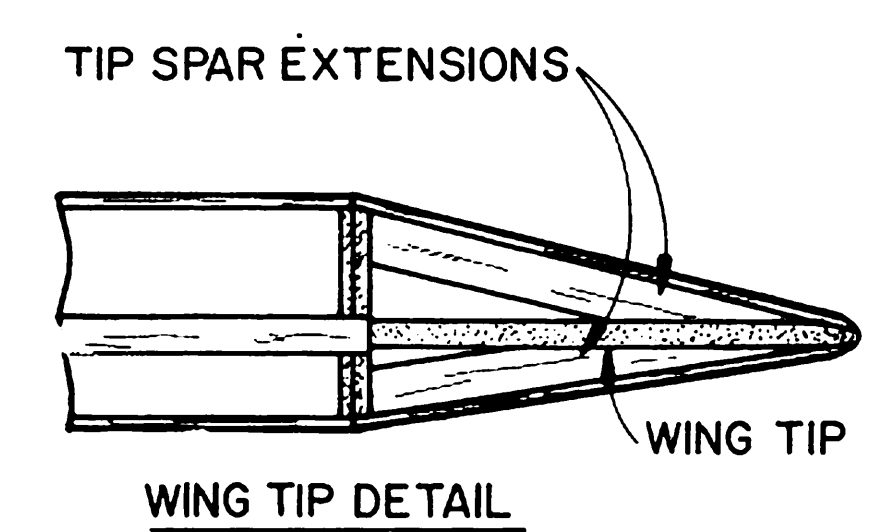

WING TIP DETAIL

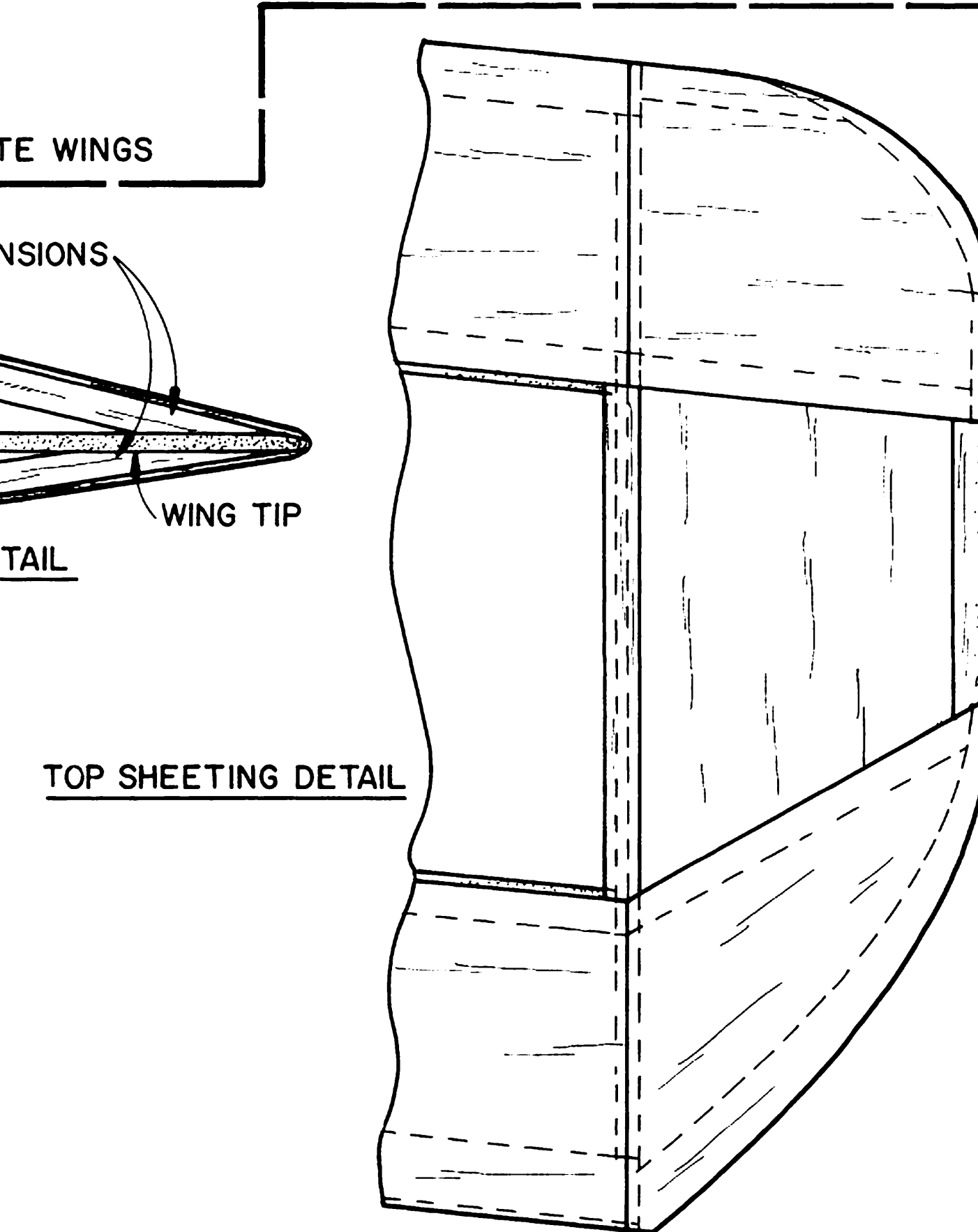

TOP SHEETING DETAIL



BOTTOM WING D ALL TOP SHEETING AND CAP STRIPS ARE OMITTED FOR CLARITY.

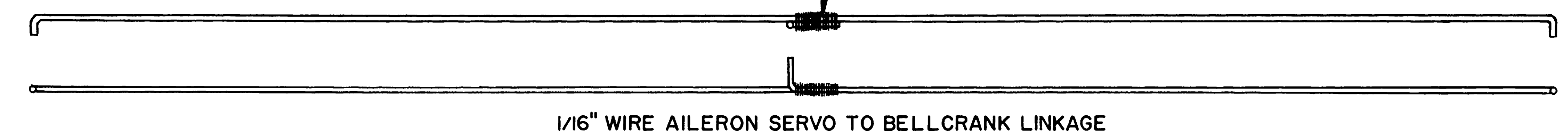

1/16\"/>

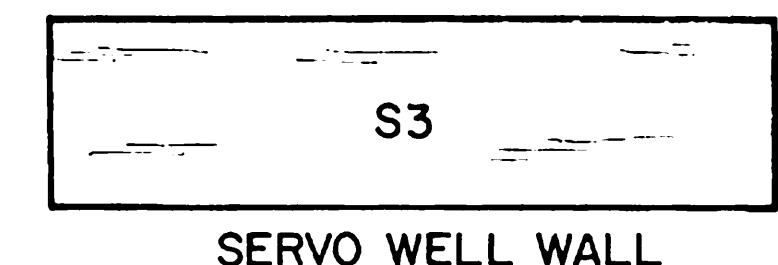

SERVO WELL WALL

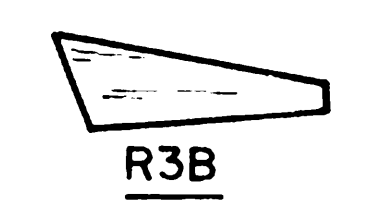

R3B

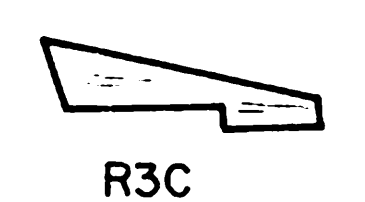

R3C

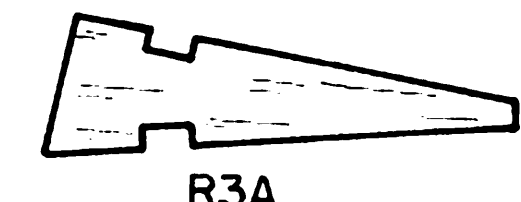

R3A

WING CONSTRUCTION

Name	Dihedral	Shape	Span
Top Wing A (short)	no	swept	48"
Bottom Wing B (short)	yes	straight	48"
Top Wing C (long)	no	swept	52-1/2"
Bottom Wing D (long)	no	swept	52-1/2"

The Super Aeromaster can be built with three different configurations. Decide now which one you will build. Configuration #1 has two short wings, Configuration #2 has one long and one short wing and Configuration #3 has two long wings. See the information on each wing here to help you decide which wings to build. Flight characteristics are similar so the choice can be based on the desired wing area and visual appearance.

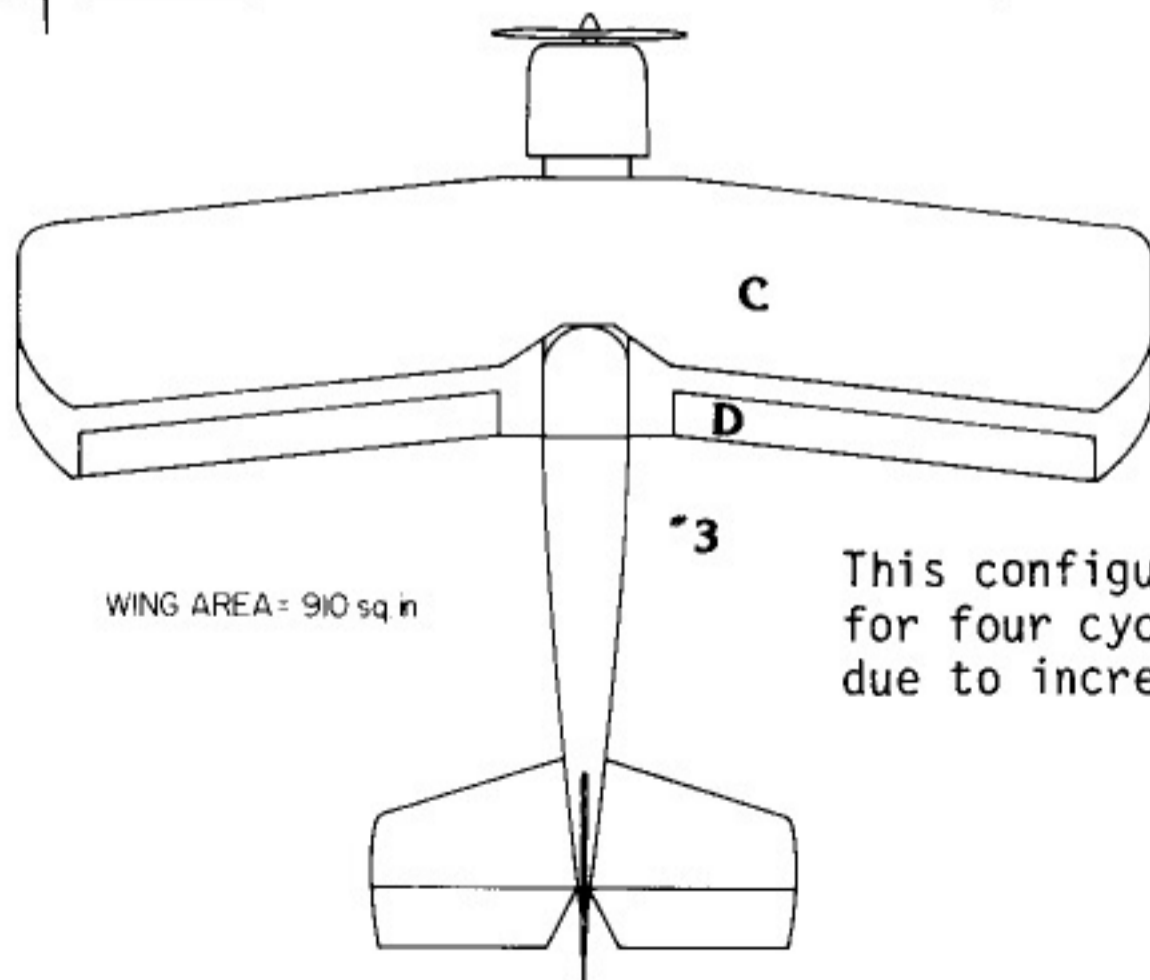
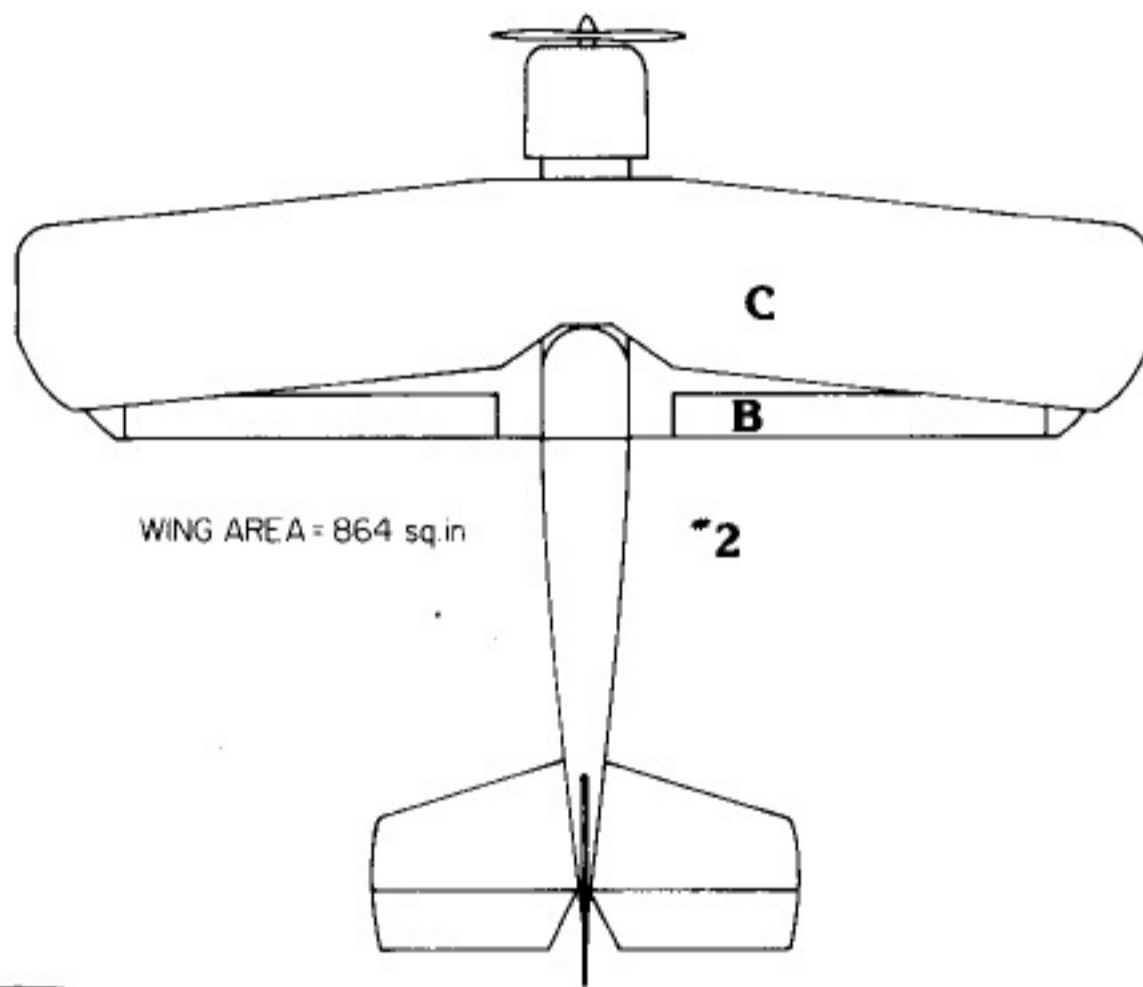
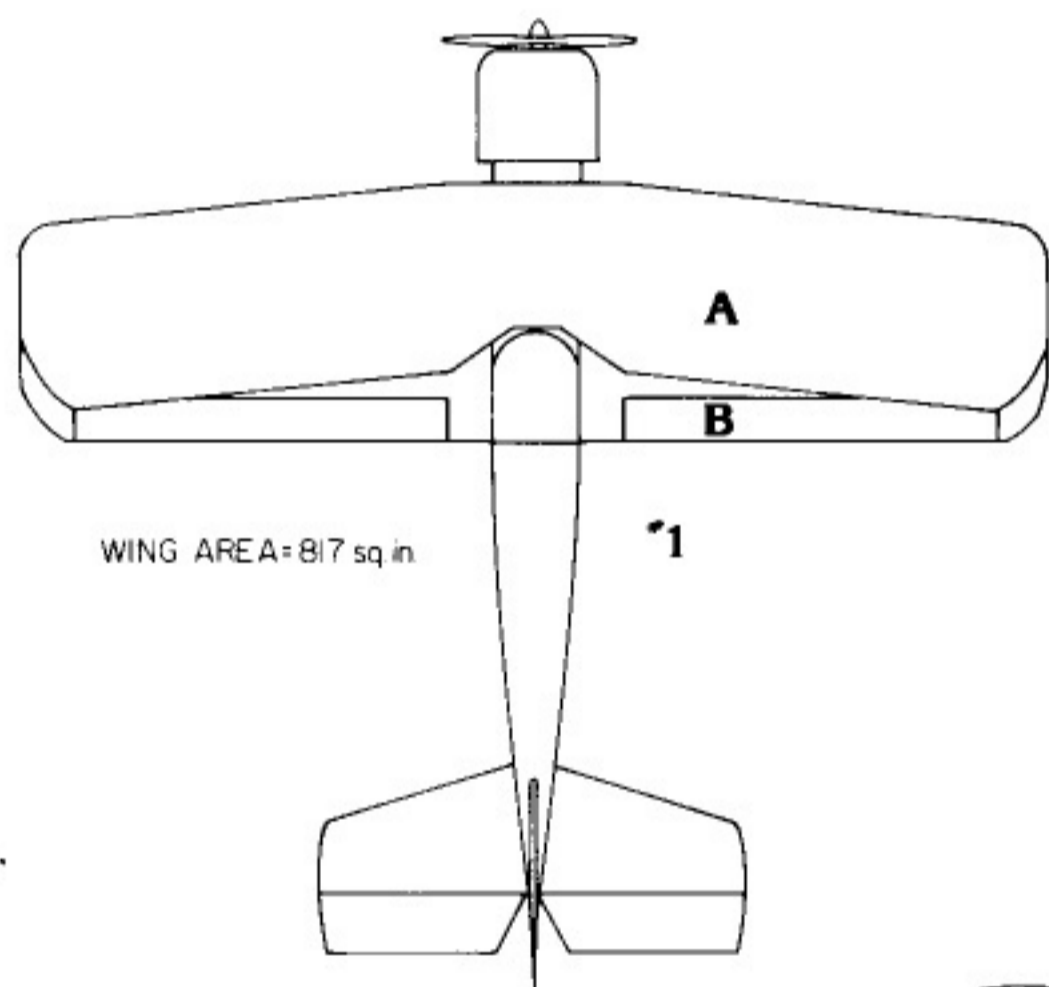

This configuration is suggested for four cycle engine installation due to increased flying weight.

Super Aeromaster Biplane

Photo Sheet

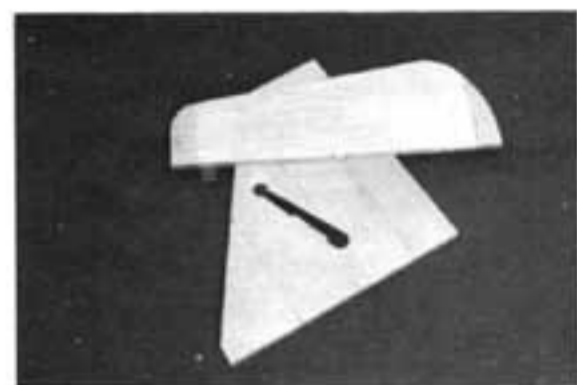

1

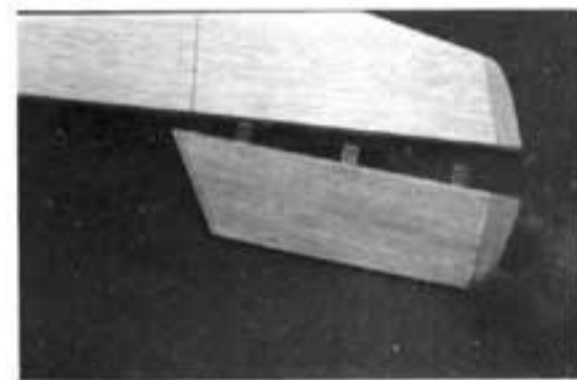

2

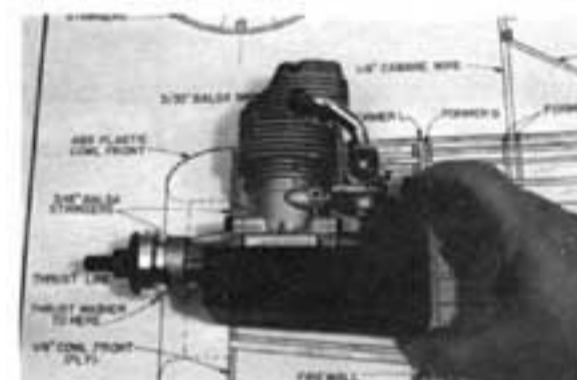

3

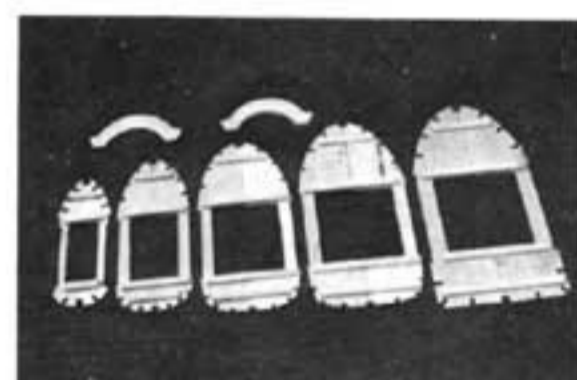

4

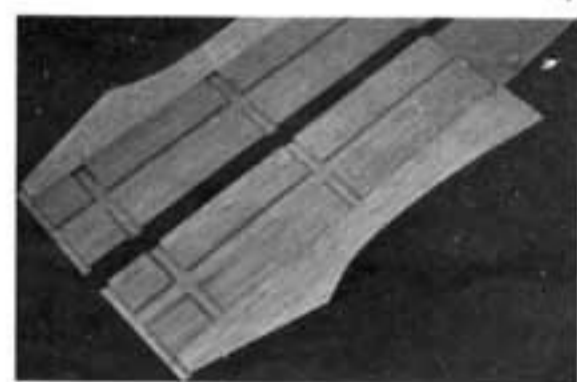

5

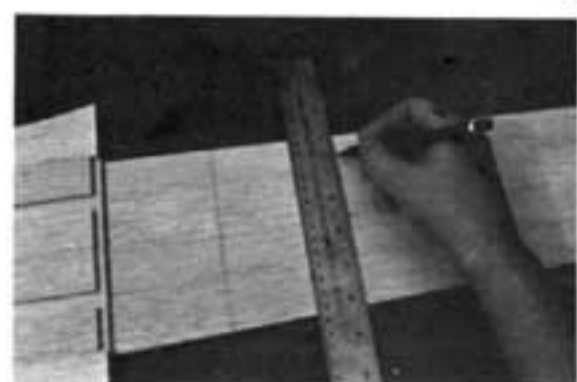

6

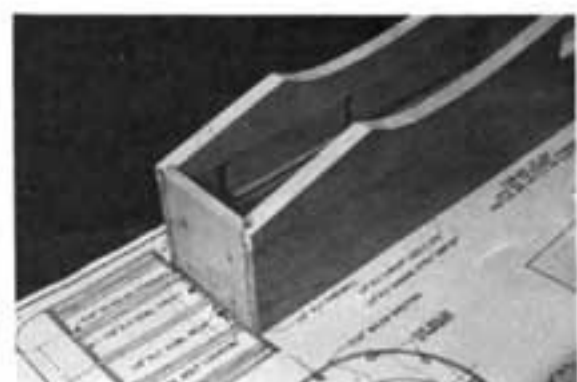

7

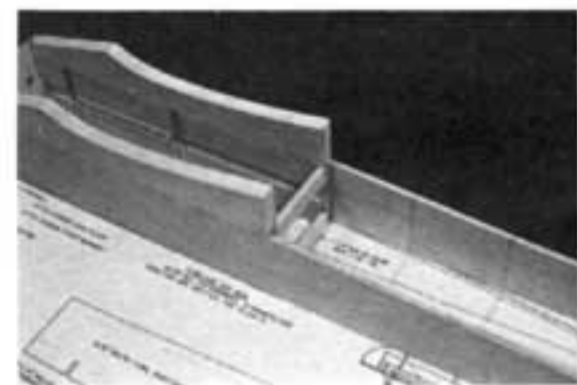

8

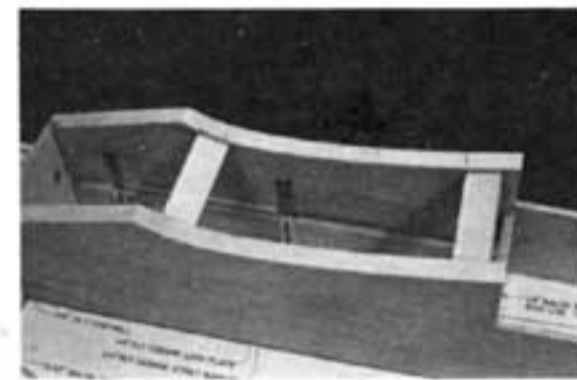

9



10



11



12

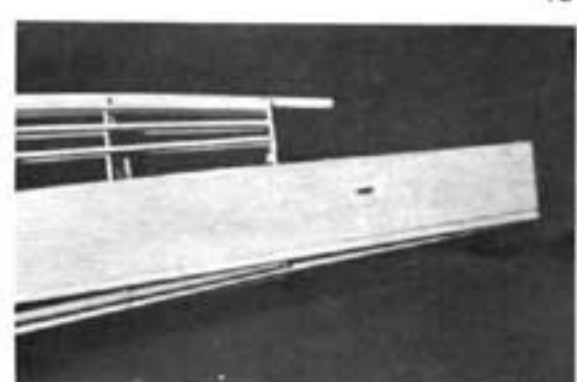

13

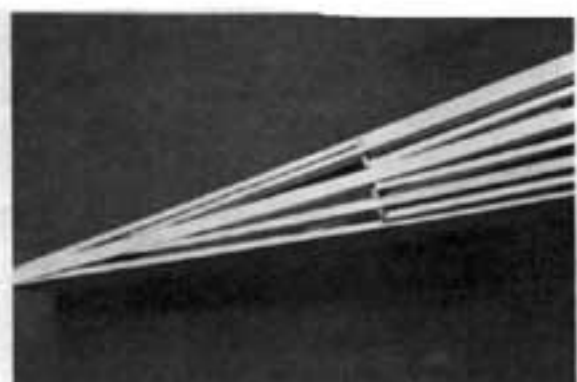

14

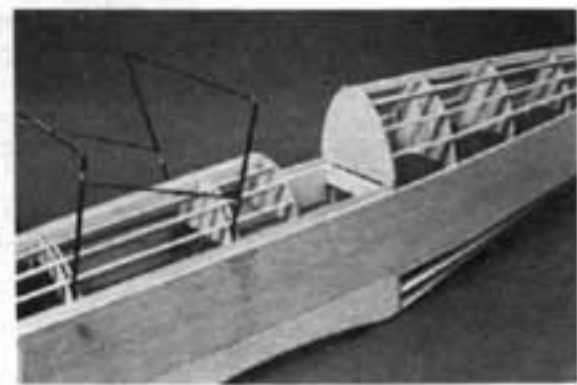

15

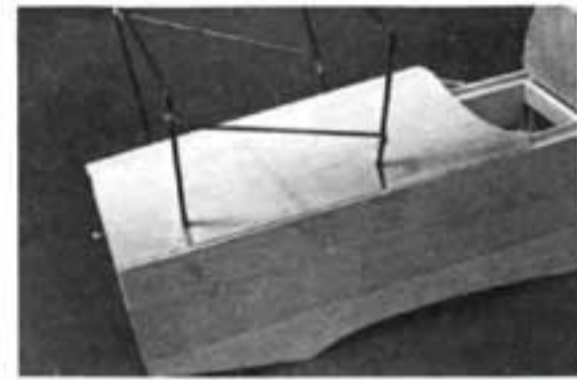

16

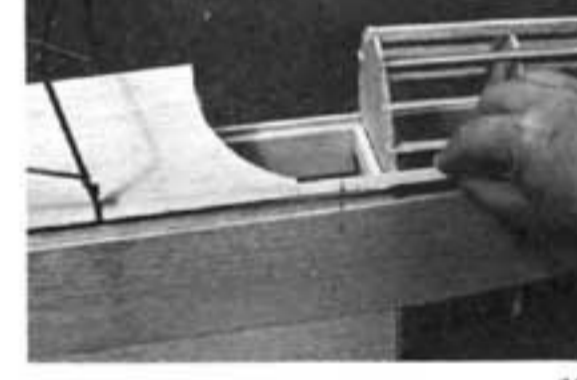

17



18



19

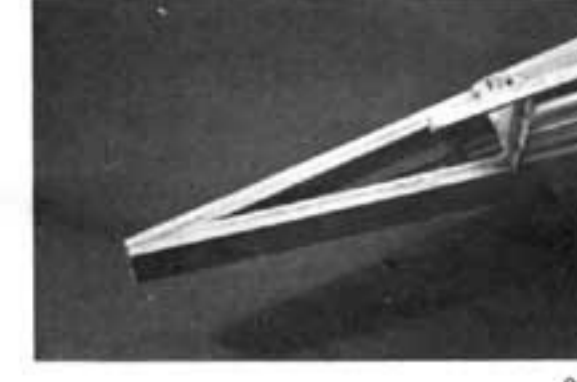

20



21

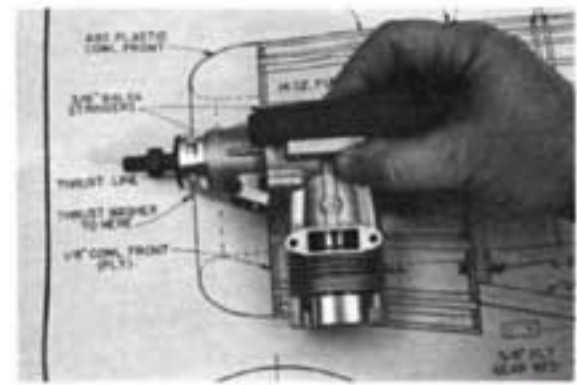

22

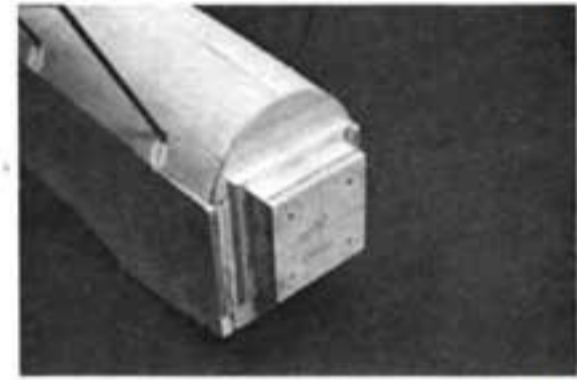

23

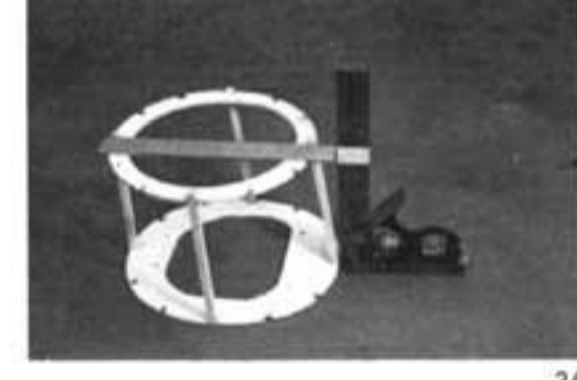

24



25

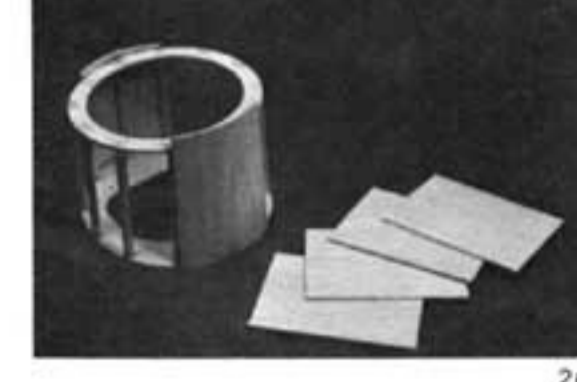

26



27



28



29

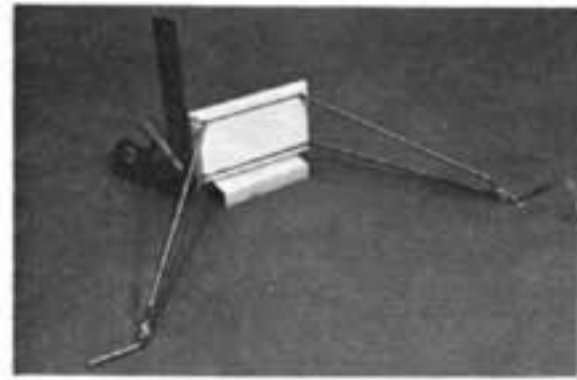

30

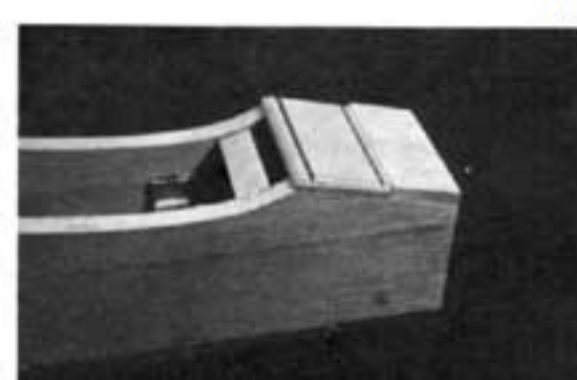

31

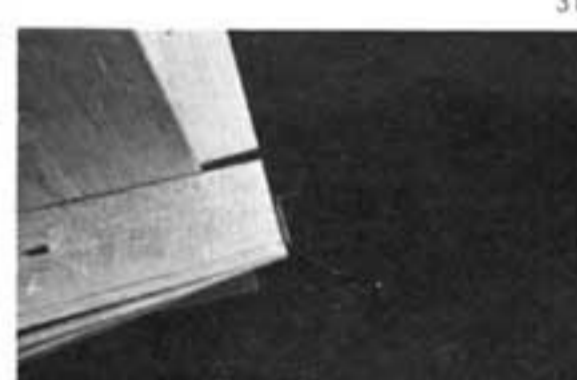

32

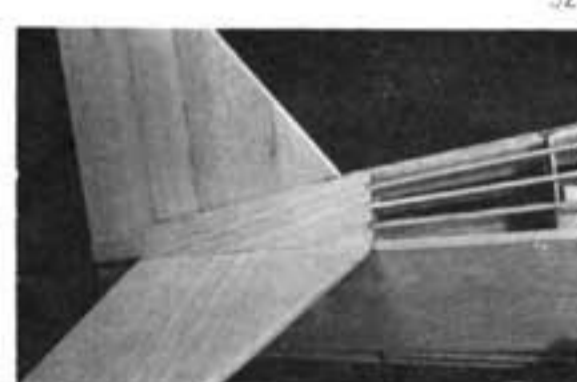

33

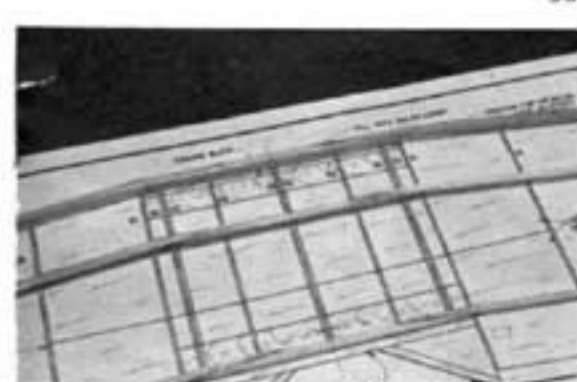

34

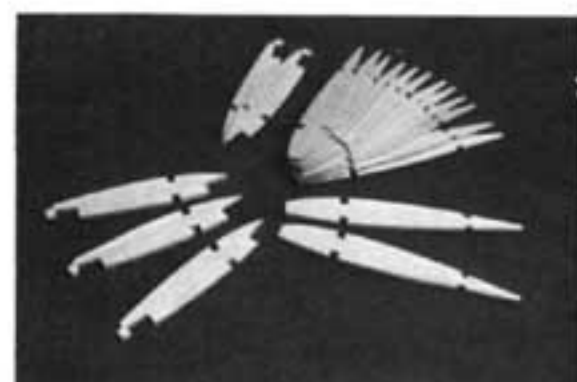

35

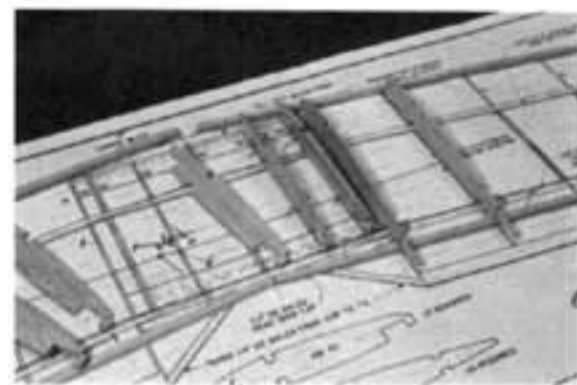

36

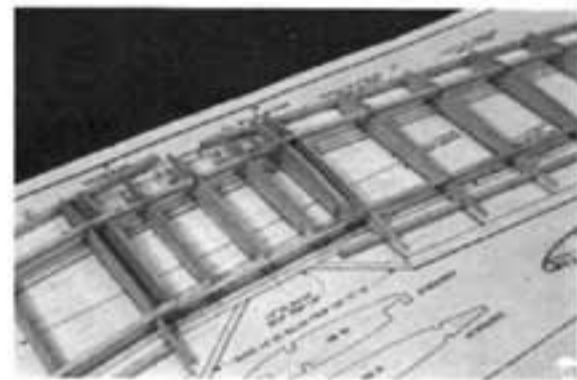

37

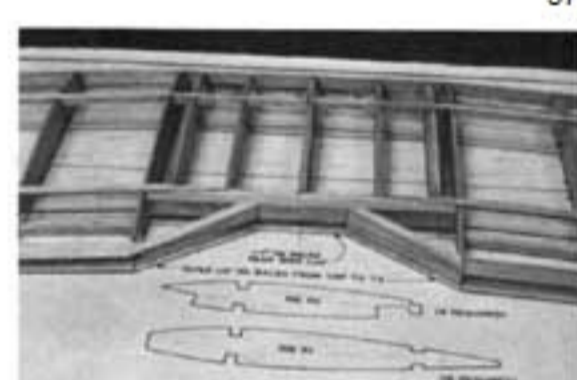

38



39

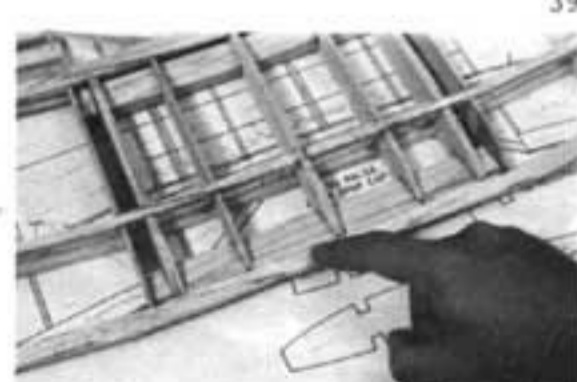

40



41



42



49



56



63

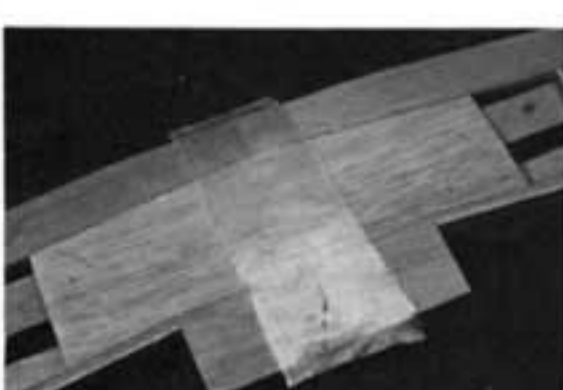

70



77



43



50



57

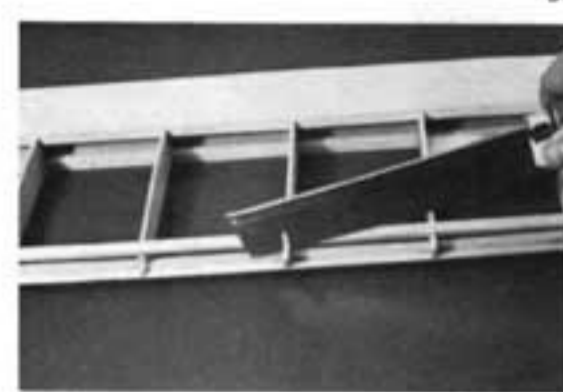

64



71



78



44



51

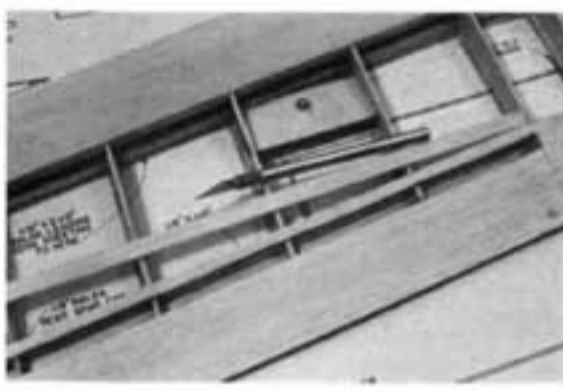

58

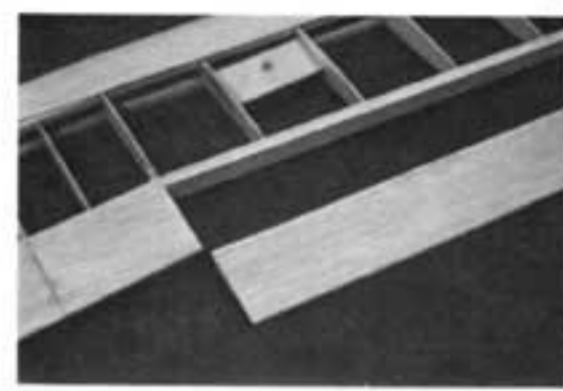

65



72



79

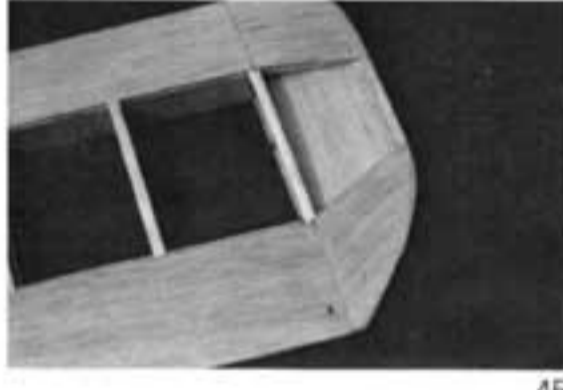

45

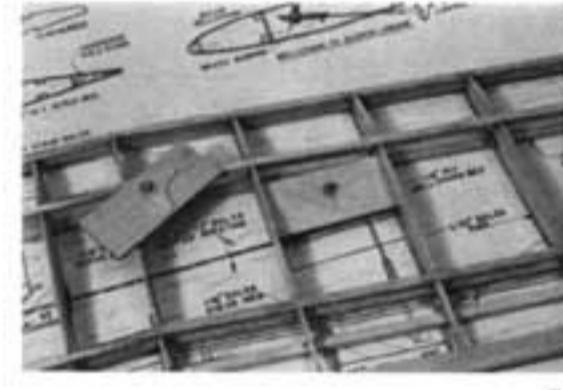

52

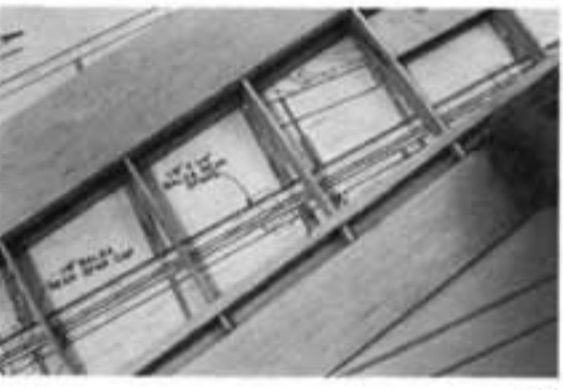

59

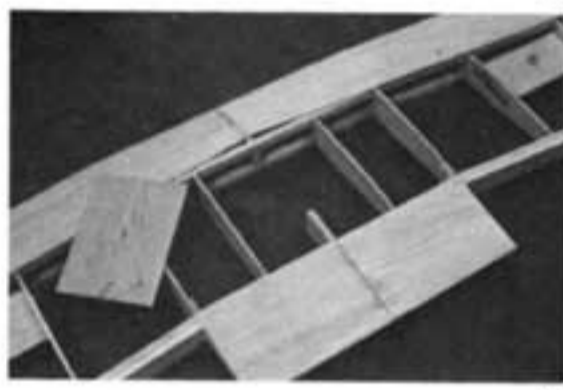

66

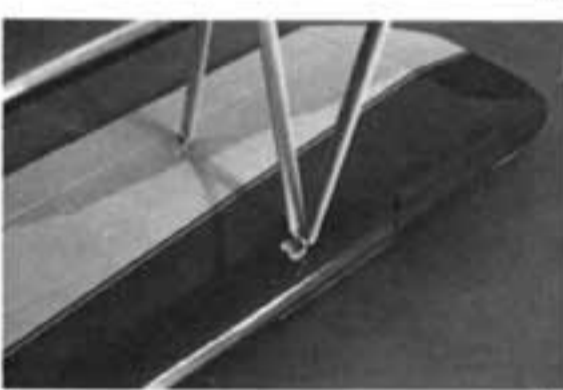

73

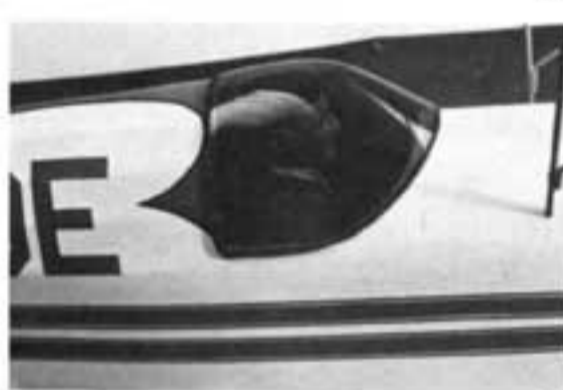

80



46

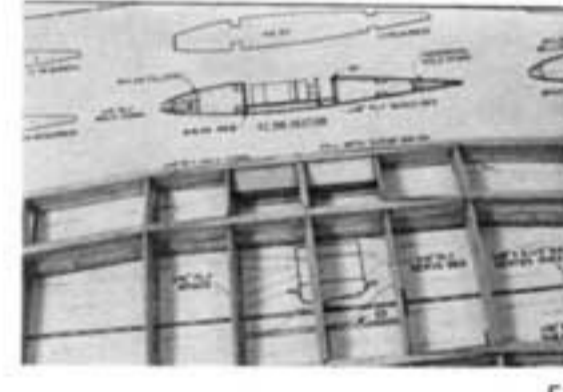

53

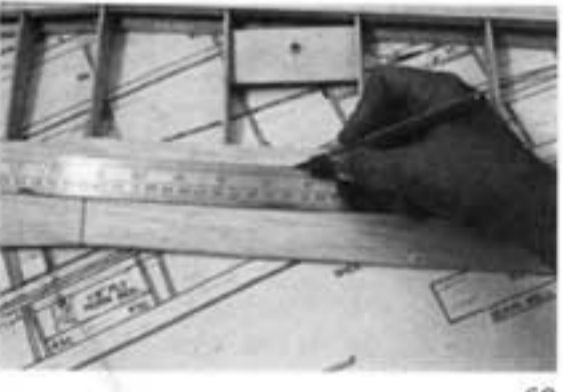

60

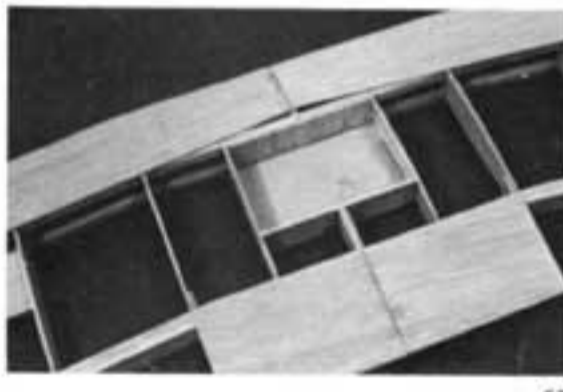

67



74

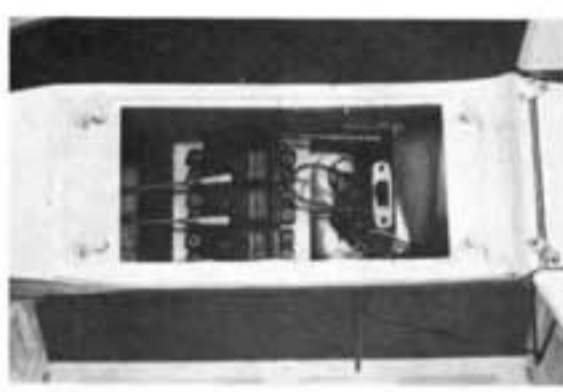

81



47

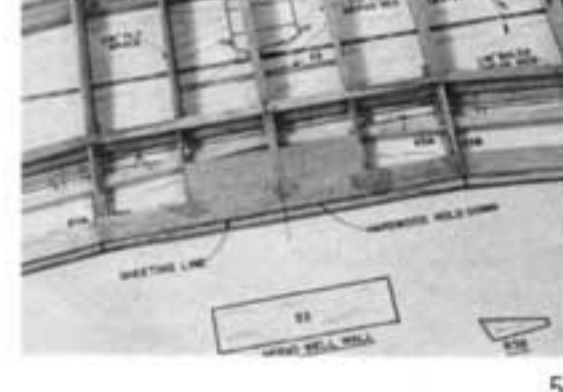

54



61



68



75

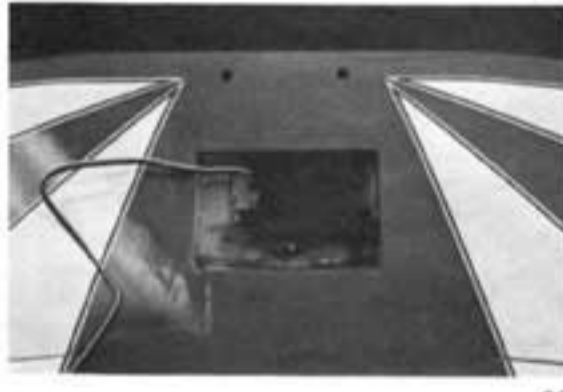

82



48

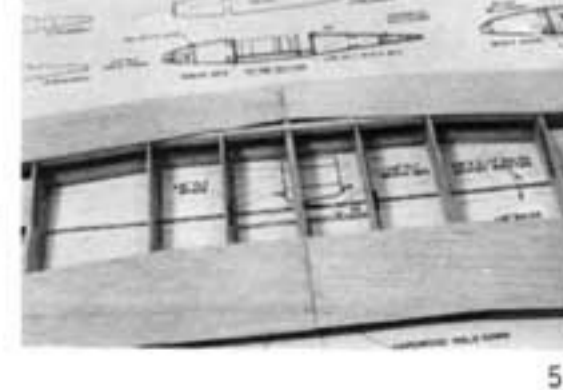

55



62



69



76



83

THROWS OF THE CONTROL SURFACES

Ailerons- 1/2" up and 1/2" down
Elevator- 3/4" up and 3/4" down
Rudder- 1-1/4" left and 1-1/4" right

The Aeromaster has exceptionally fine ground handling characteristics and does not easily ground loop. The Aeromaster is a very docile and easy to fly model that can also be tossed around and made to perform almost violently if desired. It has a very clean and semi-fast rate of flight speed and the speed is rather constant during maneuvers. The Aeromaster also has a fantastic high glide ratio both in a dead stick approach or low motor approach and has to be slowed down by inducing angle of attack as in a three point landing approach. The Aeromaster can be brought up much higher on angle of attack than just mentioned without stalling out if desired. Two wheel landings can be had after first slowing model down with angle of attack and then raising the tail just before the touchdown. If you have enough room such as at big contests, long, low angle of attack approaches can be made with either two or three point landings. The model is extremely stable during landing maneuvers and also very responsive to all control surfaces except rudder. The rudder is most effective during maneuvers such as wing overs, spins, knife edge flight, etc. but a little slower on most other maneuvers and actually you don't ever use the rudder except for these maneuvers or to steer the model on the ground...Ailerons are used more than anything for most maneuvers combined with elevator and motor control...On the Aeromaster, the rudder will only yaw the model and not bank it...Because the Aeromaster is proportioned like the large bi-planes, torque from the motor has to be considered especially during takeoffs and landings. If you gun the motor from a standstill or when coming in very slowly the airplane will tend to bank to the left. It therefore is very important to slowly advance the motor speed on takeoff and landing. The best and most controllable takeoffs are to slowly roll the model on three wheels, raise the tail, advance the throttle slowly to full and away you go. From here on its all yours. Good flying."