

TOP VIEW OF FUSELAGE
TOP AND BOTTOM SHEETING AND STRINGERS REMOVED FOR CLARITY

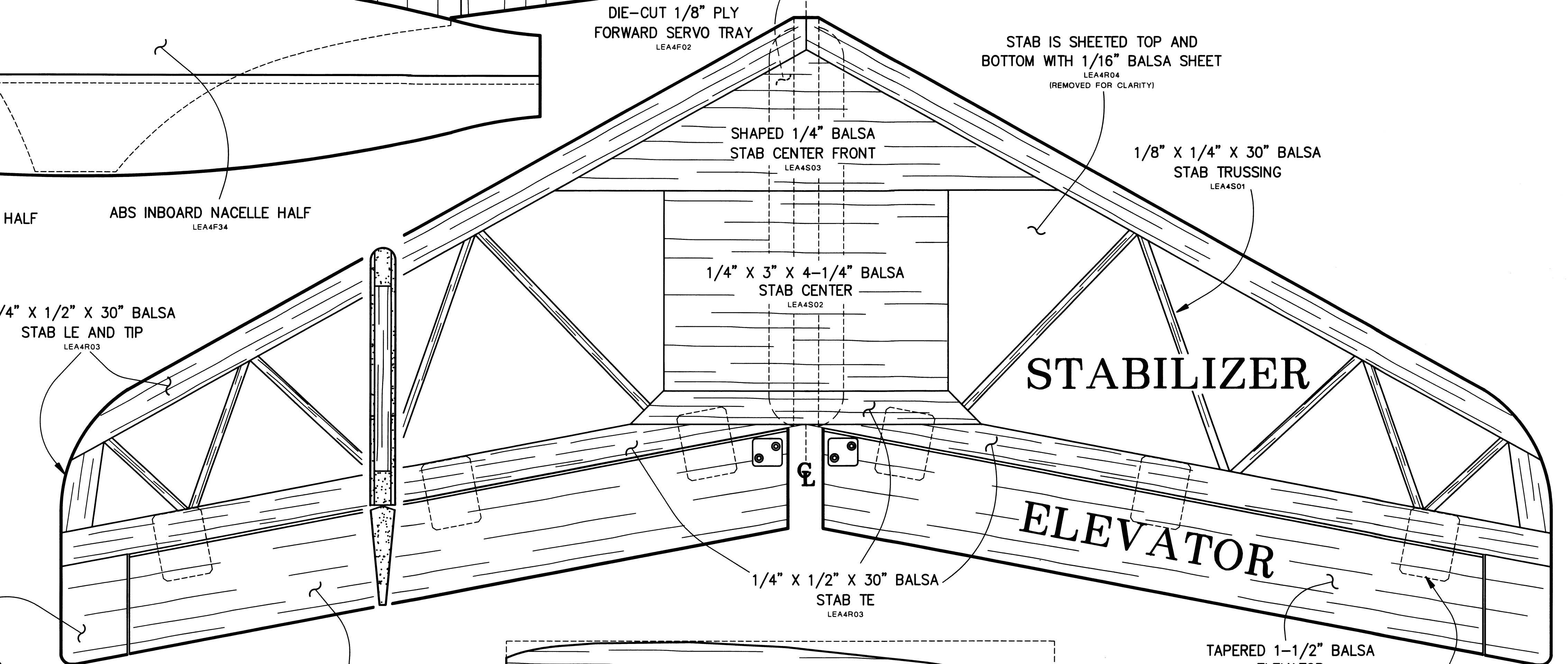

RADIO COMPARTMENT BOTTOM VIEW
LOOKING THROUGH THE HATCH



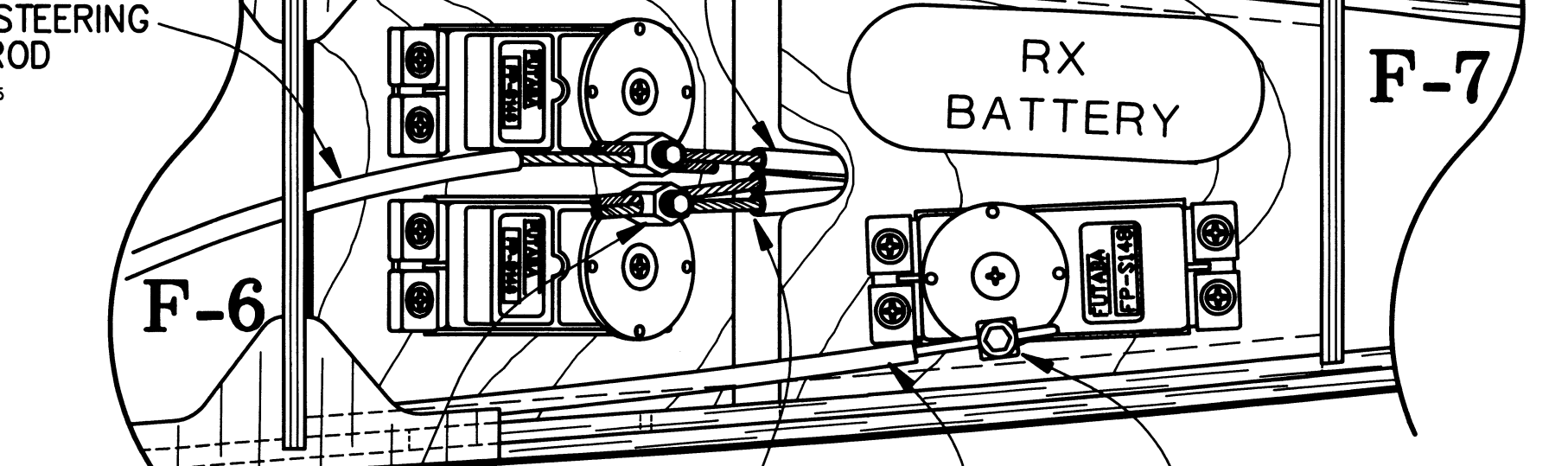

LEFT SIDE VIEW OF FUSELAGE
LEFT SIDE SHEETING, DOUBLERS AND STRINGERS REMOVED FOR CLARITY



FUSELAGE PLAN
PLAN NO. LEA4P01

Learjet .40

DESIGNED BY: JIM FELDMANN
DRAWN BY: JIM FELDMANN & CRAIG GOLEMA
KIT ENGINEERING BY: CRAIG GOLEMA
INSTRUCTIONS BY: ROB TALBOT-JONES

ALL COMMERCIAL RIGHTS RESERVED © 1995 P.O. Box 788 Urbana, Illinois 61801 (217) 398-8870

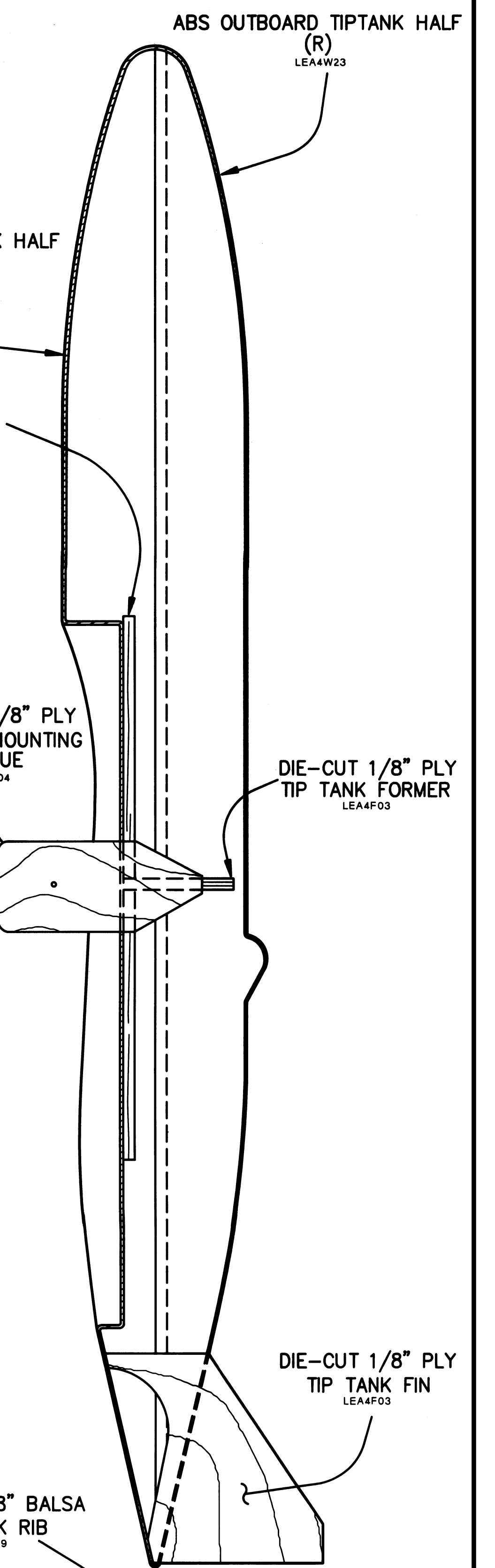
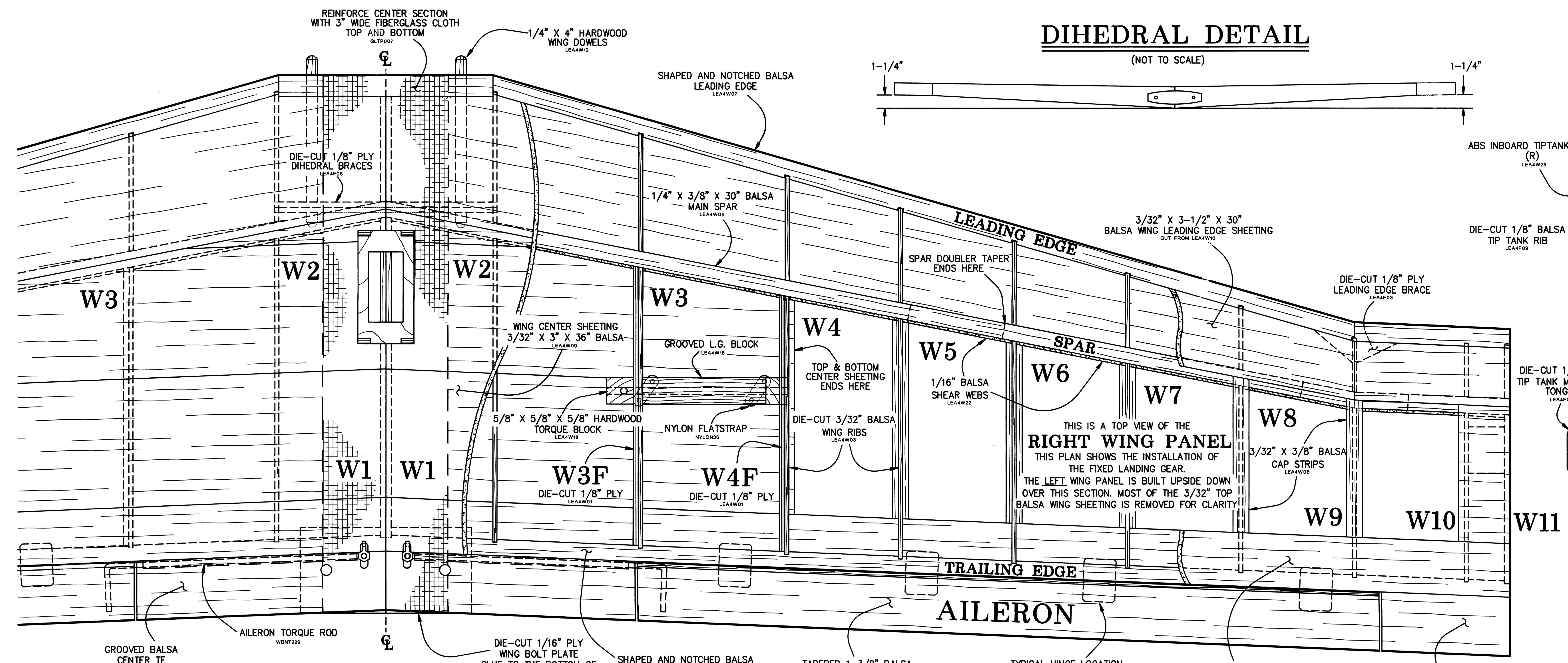

RETRACT INSTALLATION DETAIL
RETRACTS ARE OPTIONAL

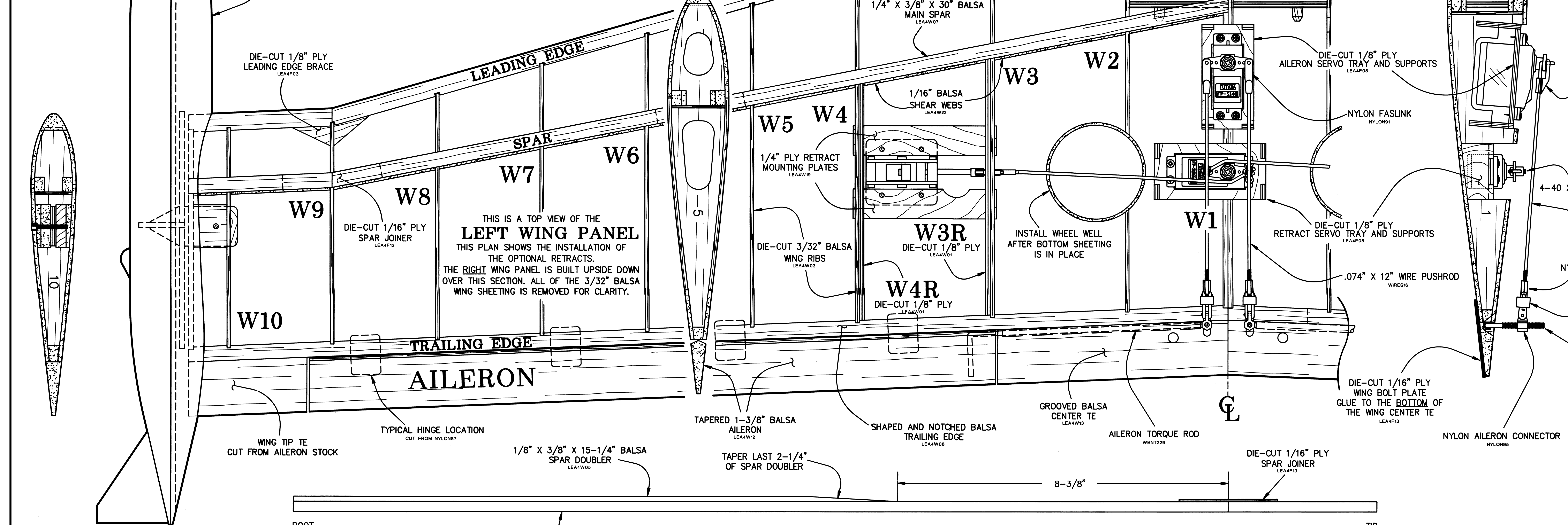
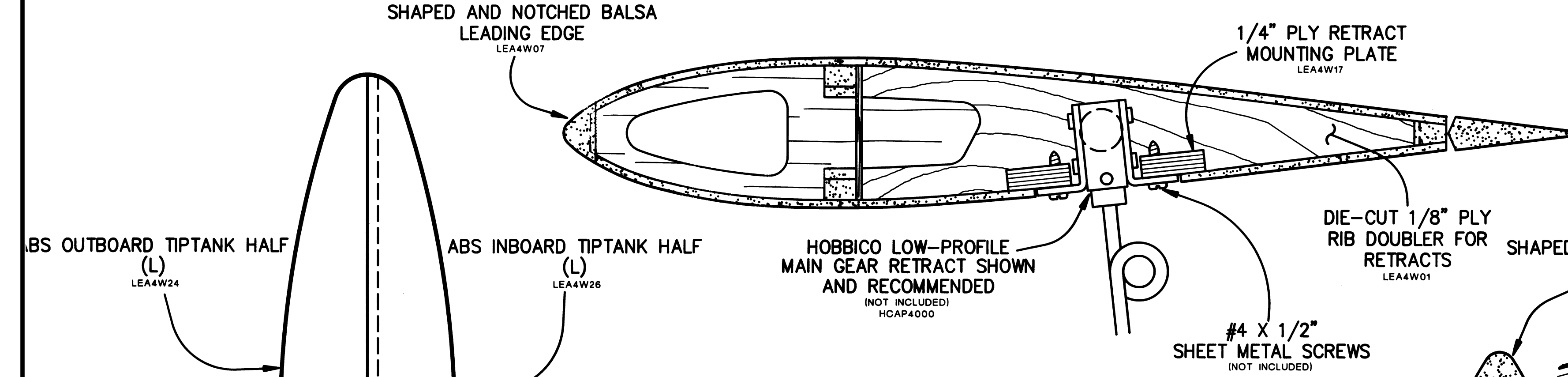

FIXED GEAR DETAIL

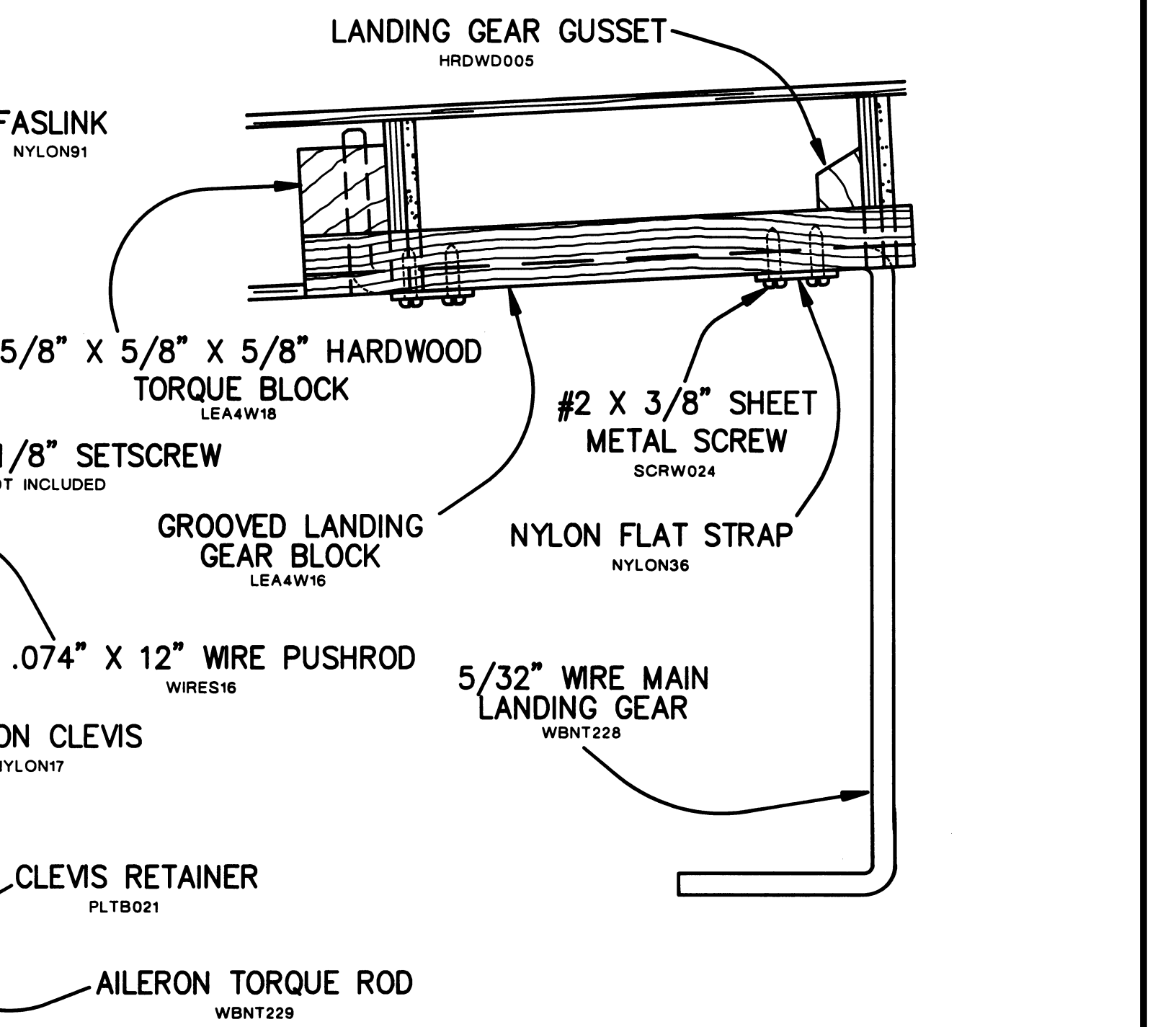

WING PLAN PLAN NO. LEA4P02

Learjet .40

DESIGNED BY: JIM FELDMANN
DRAWN BY: JIM FELDMANN & CRAIG GOLEMA
KIT ENGINEERING BY: CRAIG GOLEMA
INSTRUCTIONS BY: ROB TALBOT-JONES

