

Note: Templates in this section have been modified to facilitate CNC/CAM fabrication. All airfoils and curves have been rendered with arc segments to minimize translation errors of the DXF file. All entities have been placed on a single layer.

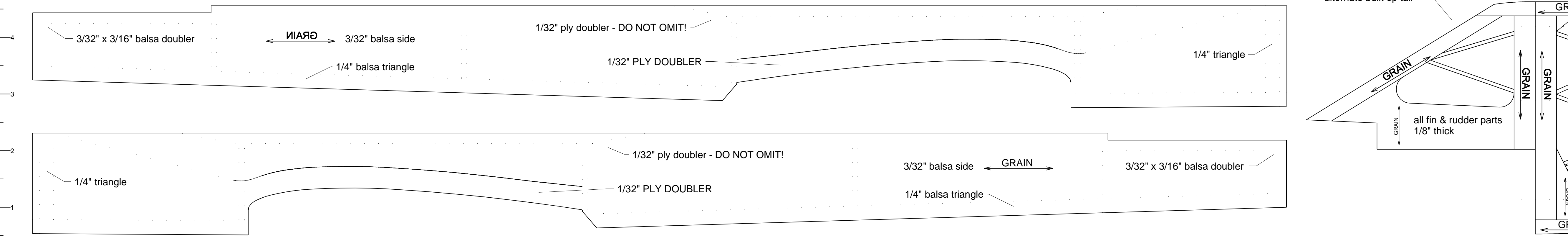
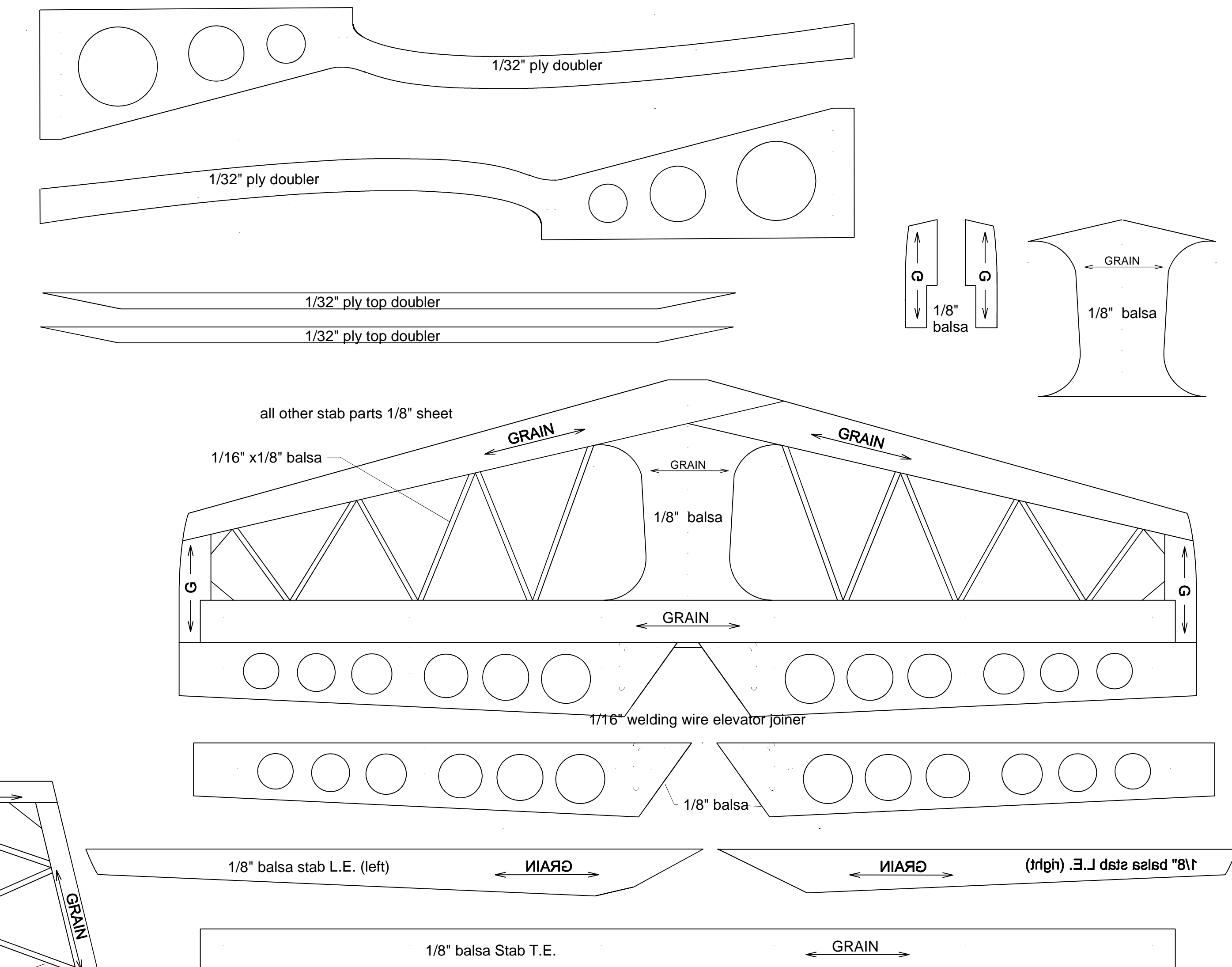
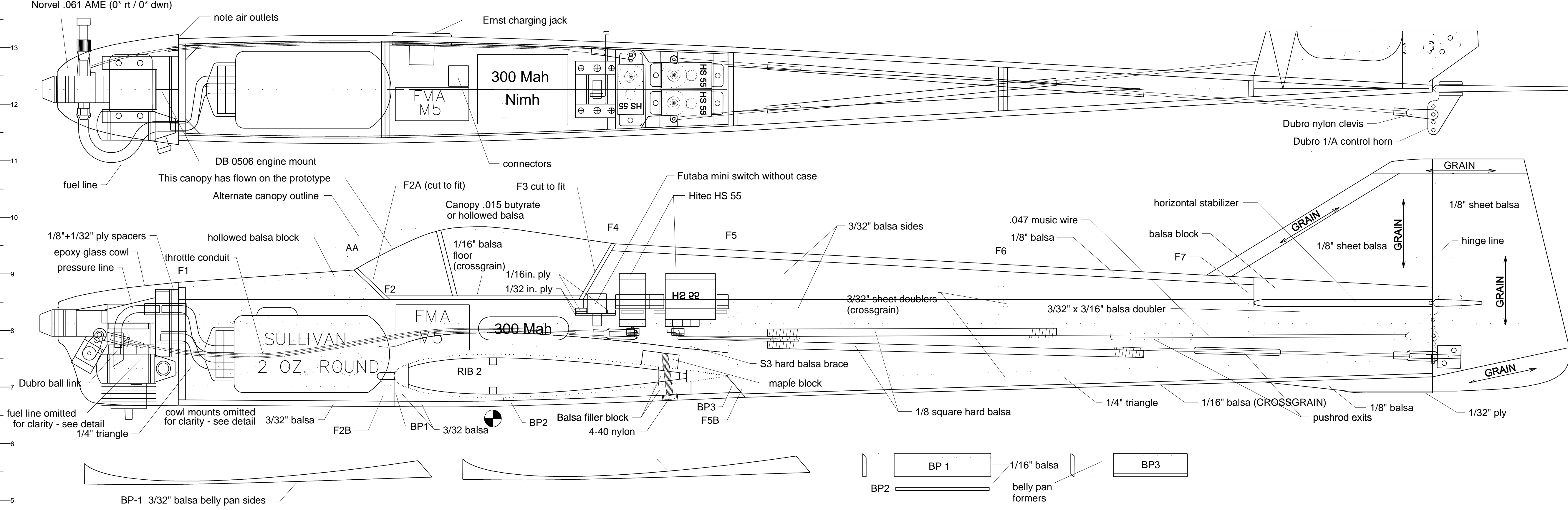
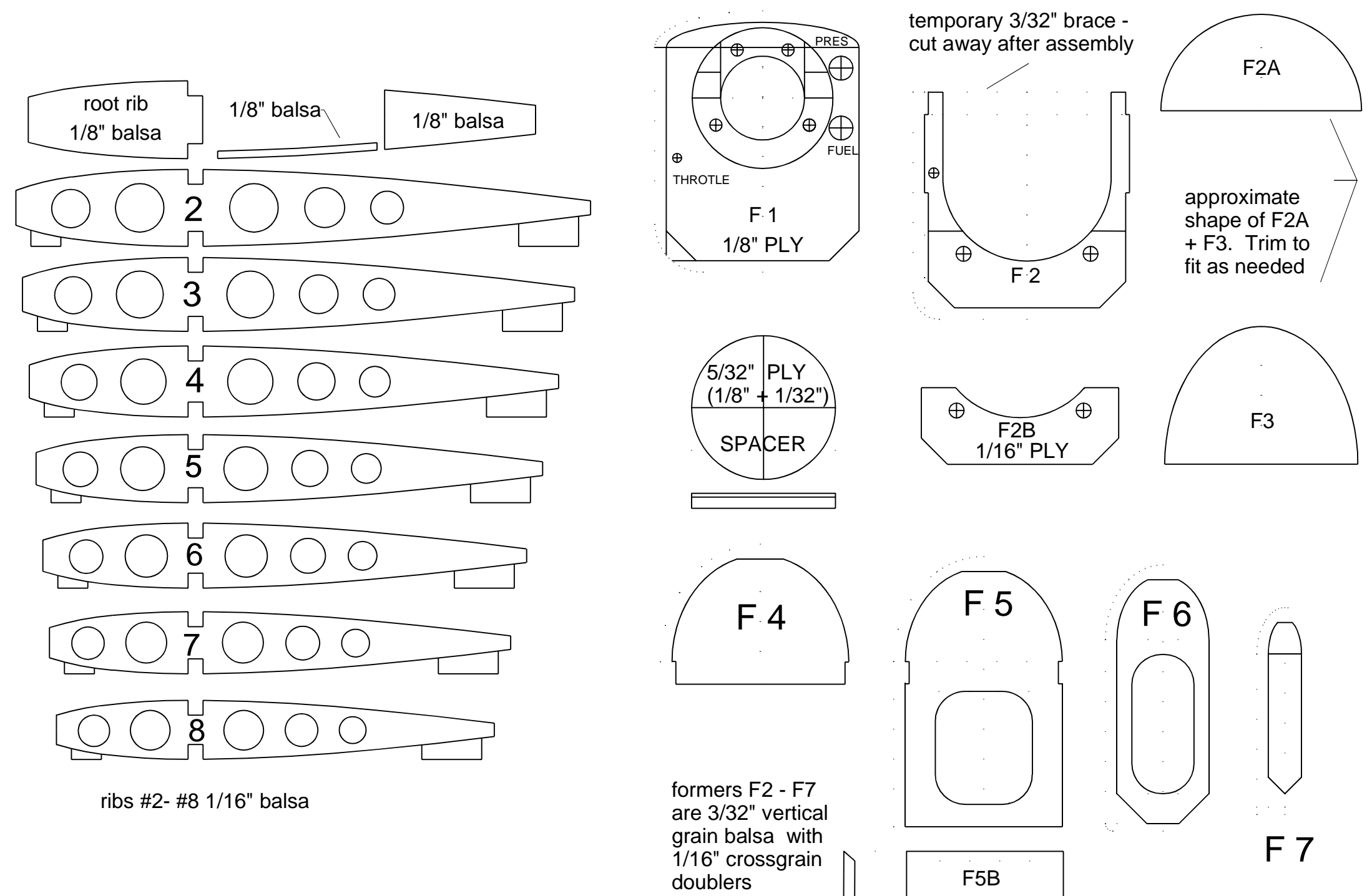
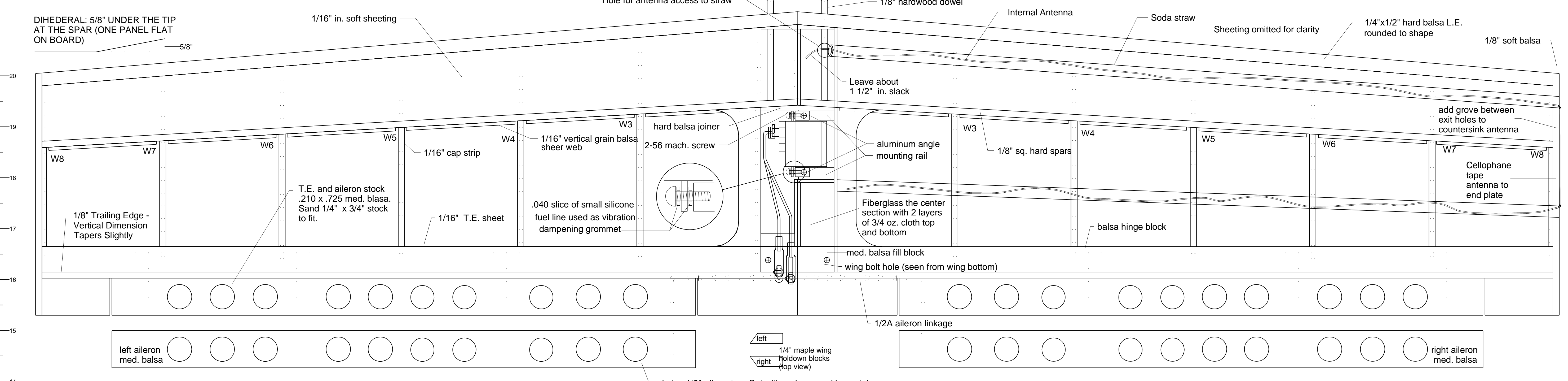
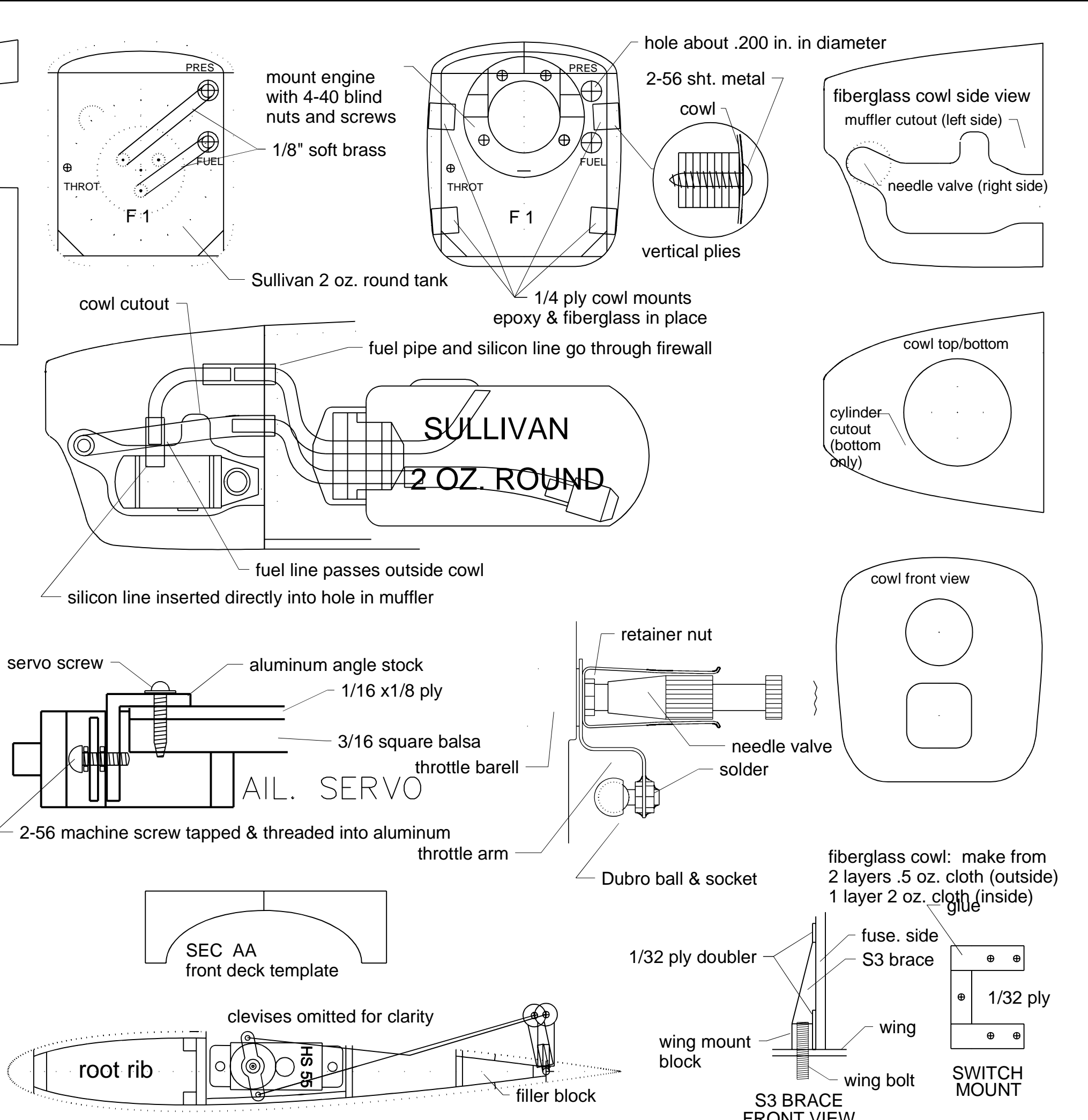

CG: On spar  
 Ailerons: +/- 1/8"  
 Elevator: +1/4" / -5/16"  
 Rudder: +/- 1/16"  
 Airfoil: NACA 0013  
 Engine: Norvel .061 AME  
 Engine Thrust: 0/0  
 Propeller: APC 5.75 x 3  
 Receiver: FMA M5  
 Servos: Hitec HS-55 (4)  
 Battery: 300 mAh NiMH

Lightness is next to verticalness!

All balsa is 4-6 lb. contest grade wood.  
 All plywood is aircraft grade birch plywood.  
 Accuracy of construction and the use of the best possible materials are the keys to the performance of this aircraft. Make every effort possible to build the aircraft straight and to minimize the all up weight of the aircraft. All control surfaces must be fully gap sealed to help reduce the chance of flutter and to allow for proper flight trimming of the model. Ensure that the C.G. and control throws are set as indicated for the first flight.  
 The Author may be contacted via Email at [fain@brightdsi.net](mailto:fain@brightdsi.net)  
 An archive of digital photos is available upon request.

Hack Aero  
 PROTOTYPE  
 DAVE RICE  
 ENGINEER  
 MOUSE DRIVER  
 WHO NEEDS IT?  
 DATE: 06/03  
 DWG NUMBER: 0003 OF LOTS  
 BUILD IT LIGHT!  
 SHEET 1 OF 1