

FRONT STRUT	3/16 X 3/8
REAR STRUT	3/16 X 3/8
VERTICAL STRUTS	2 EA 3/16 X 3/8
CROSS STRUT	3/16 X 3/8
<div style="display: flex; justify-content: space-between; width: 100%;"> 2 9/16 3 3/4 </div>	
<div style="display: flex; justify-content: space-between; width: 100%;"> 19 3/4 20 1/32 </div>	

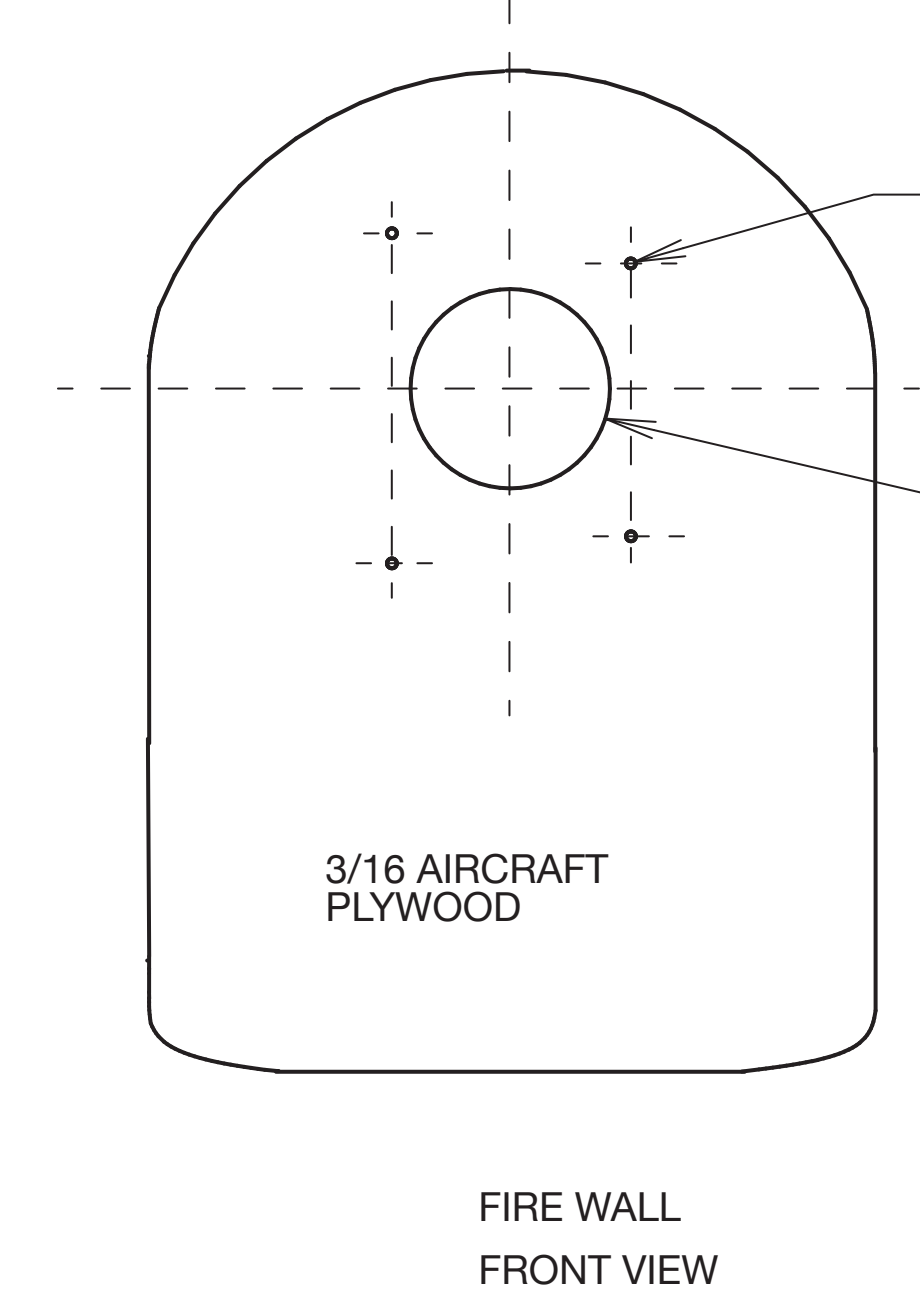

DRILL NO. 28 FOUR PLACES
INSTALL 6-32 CAPTIVE NUTS
PATTERN IS FOR J-TEC J-48
ALUMINUM ENGINE MOUNT
DRILL 1.0 IN DIA.
FOR FUEL TANK STOPPER

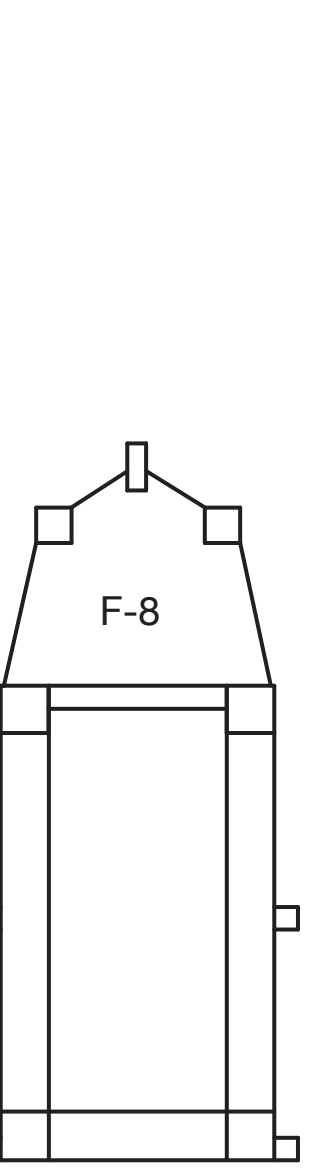
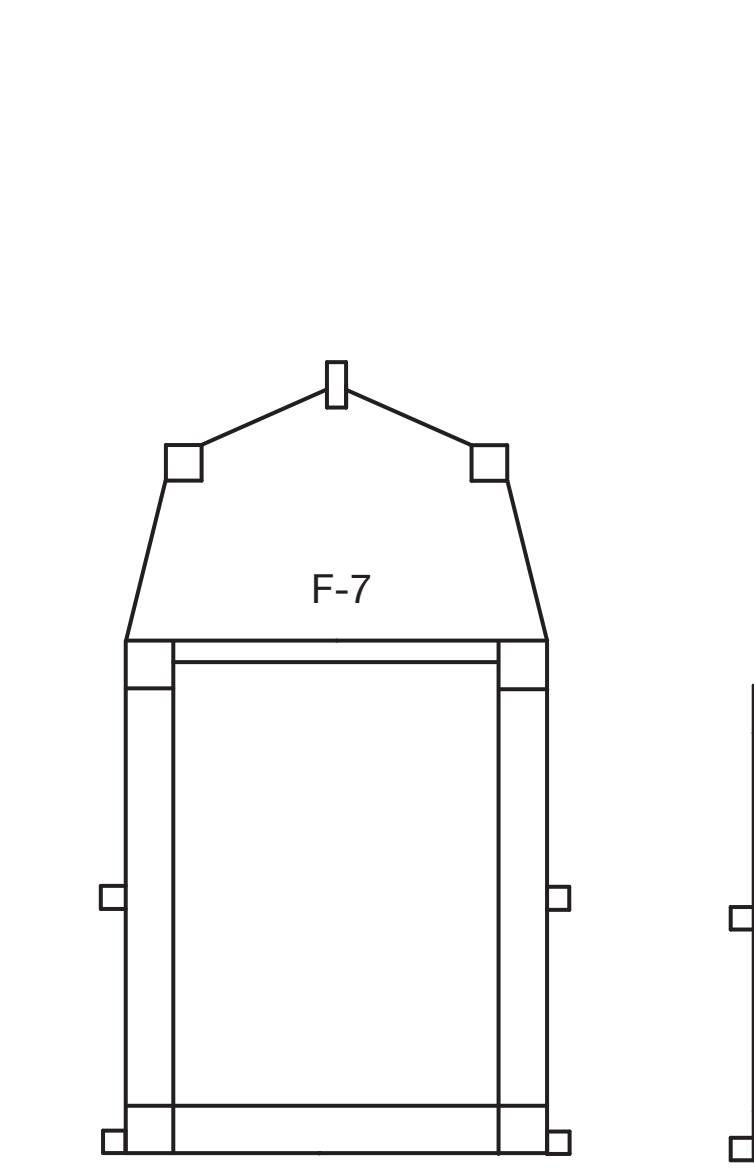
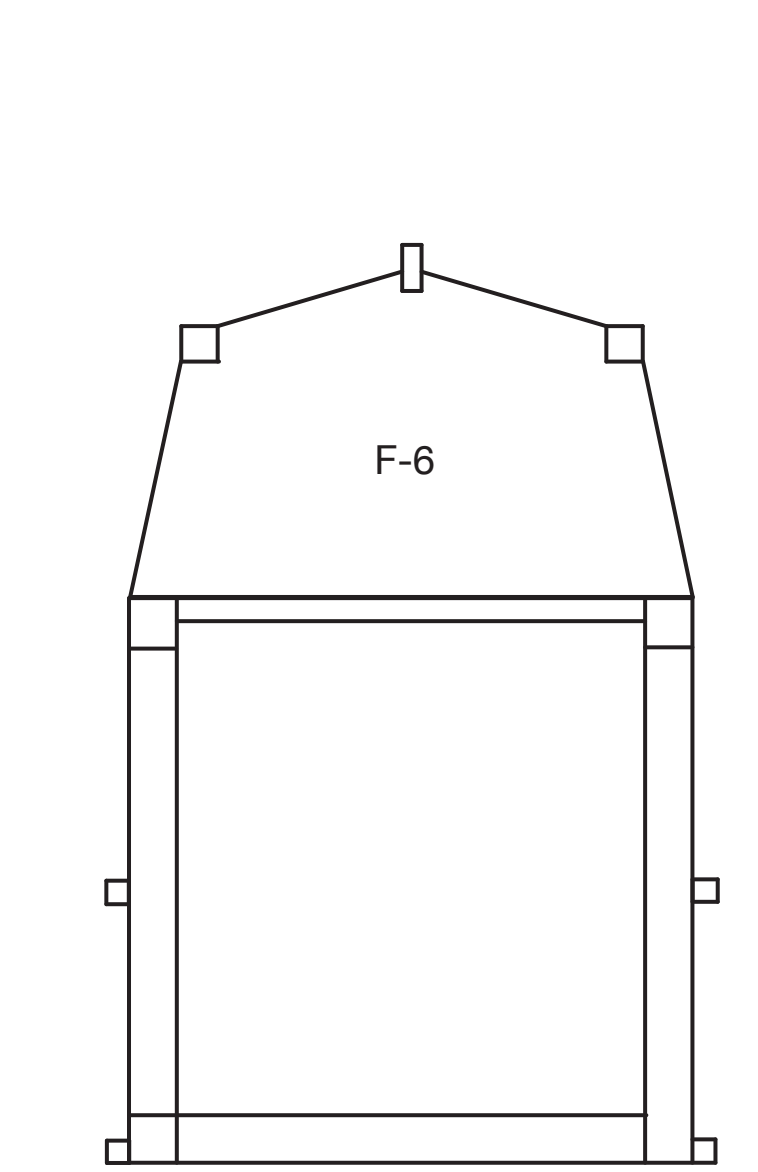
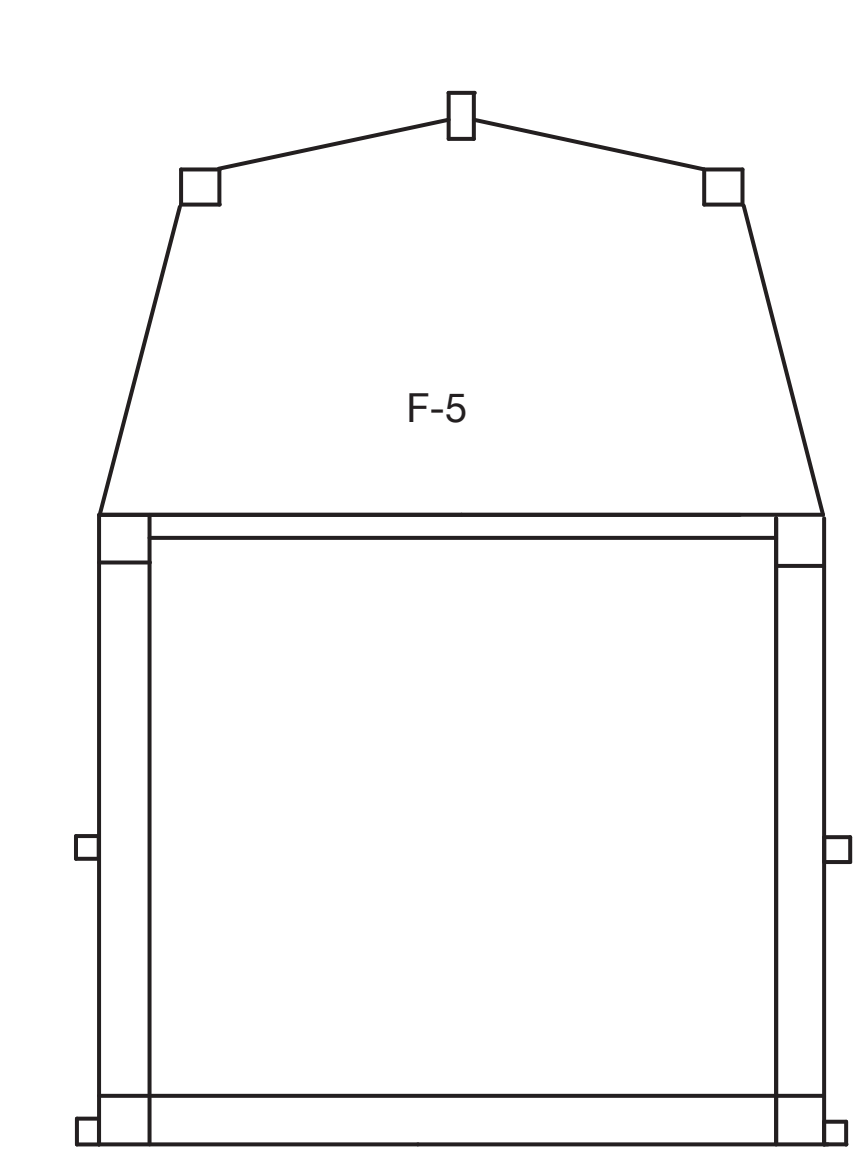
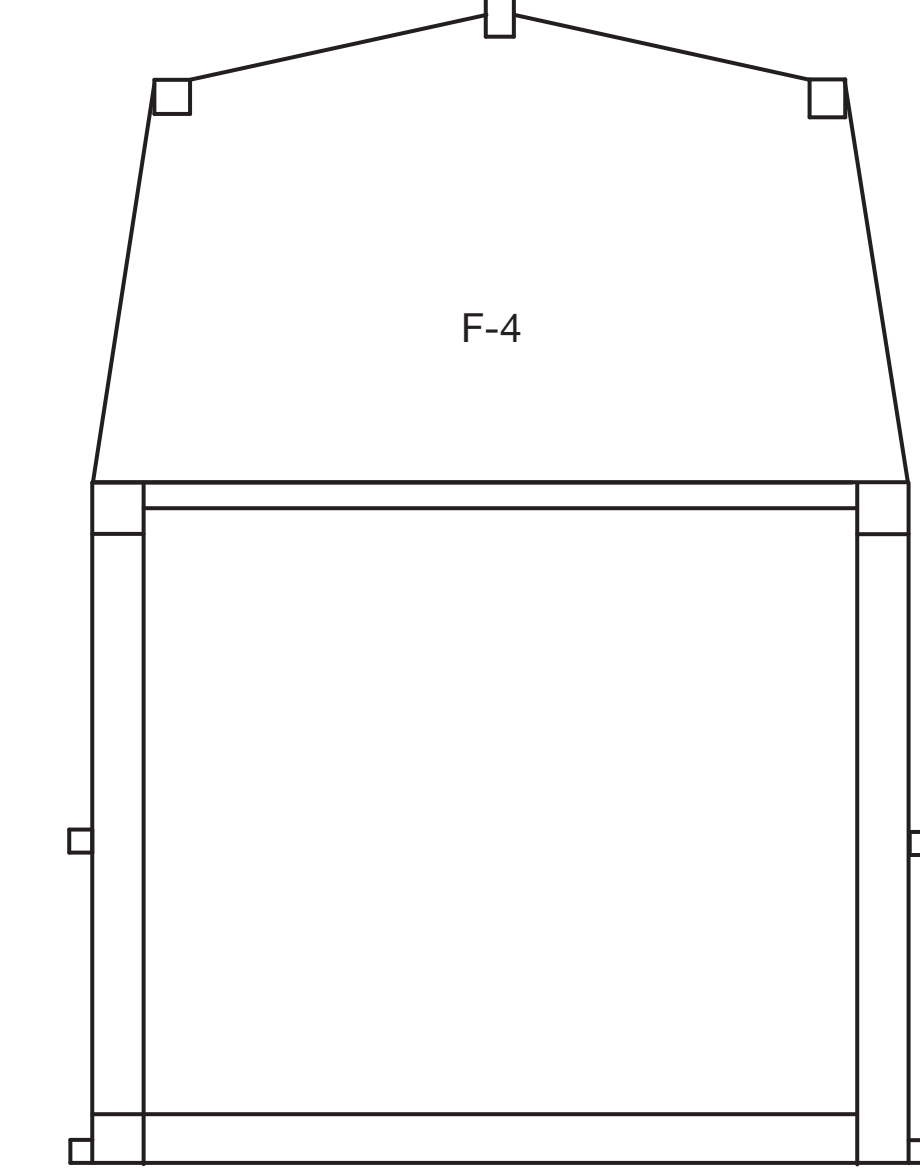
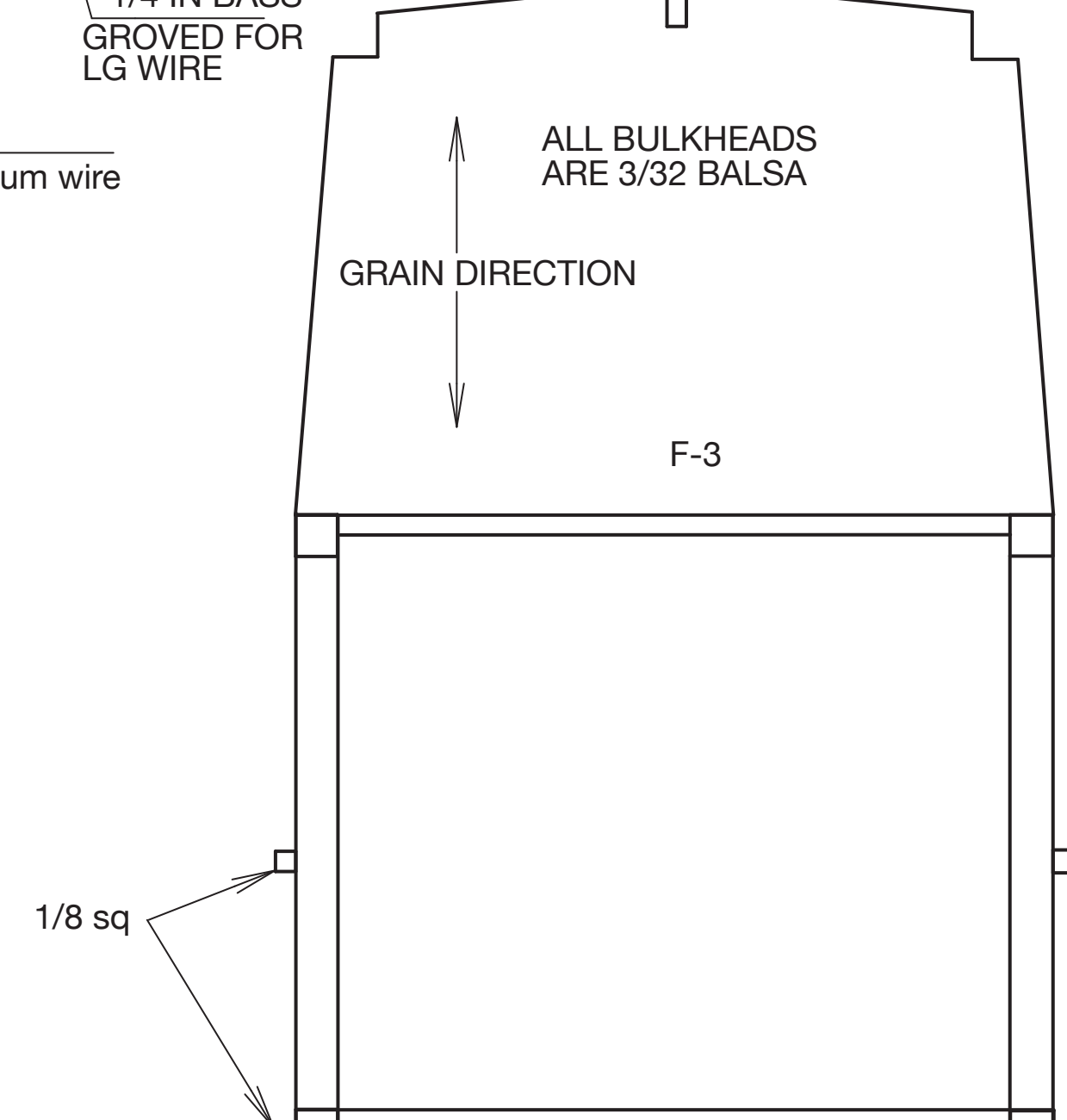
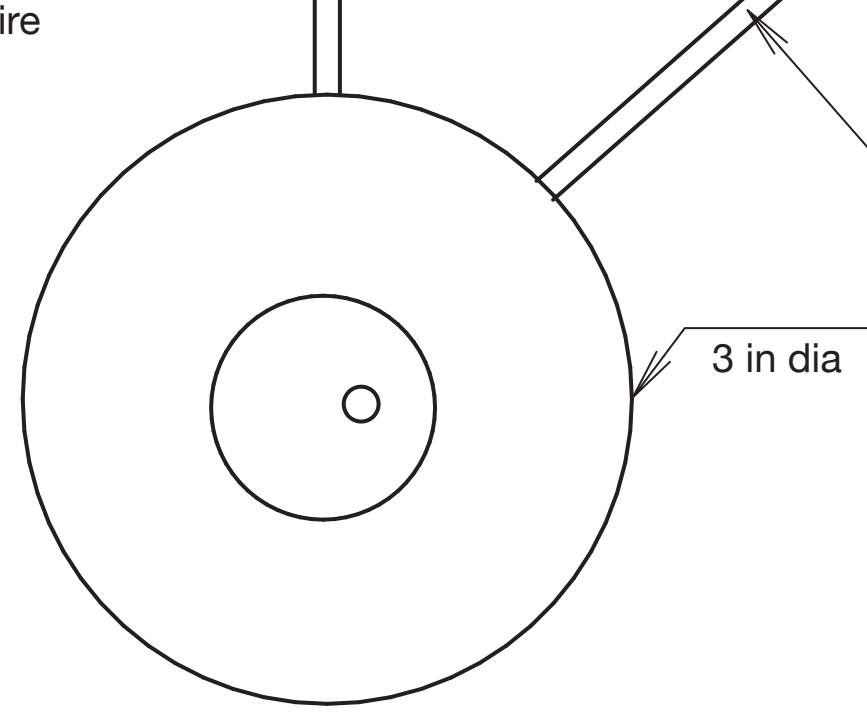
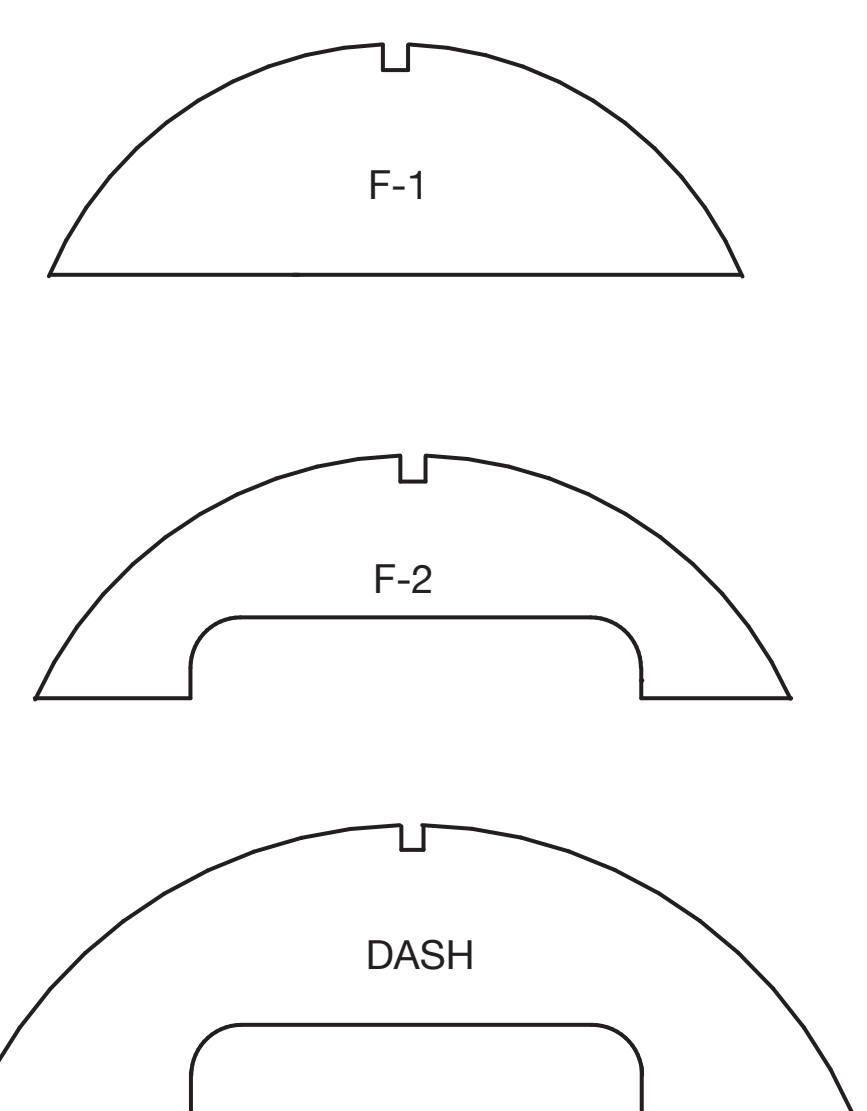
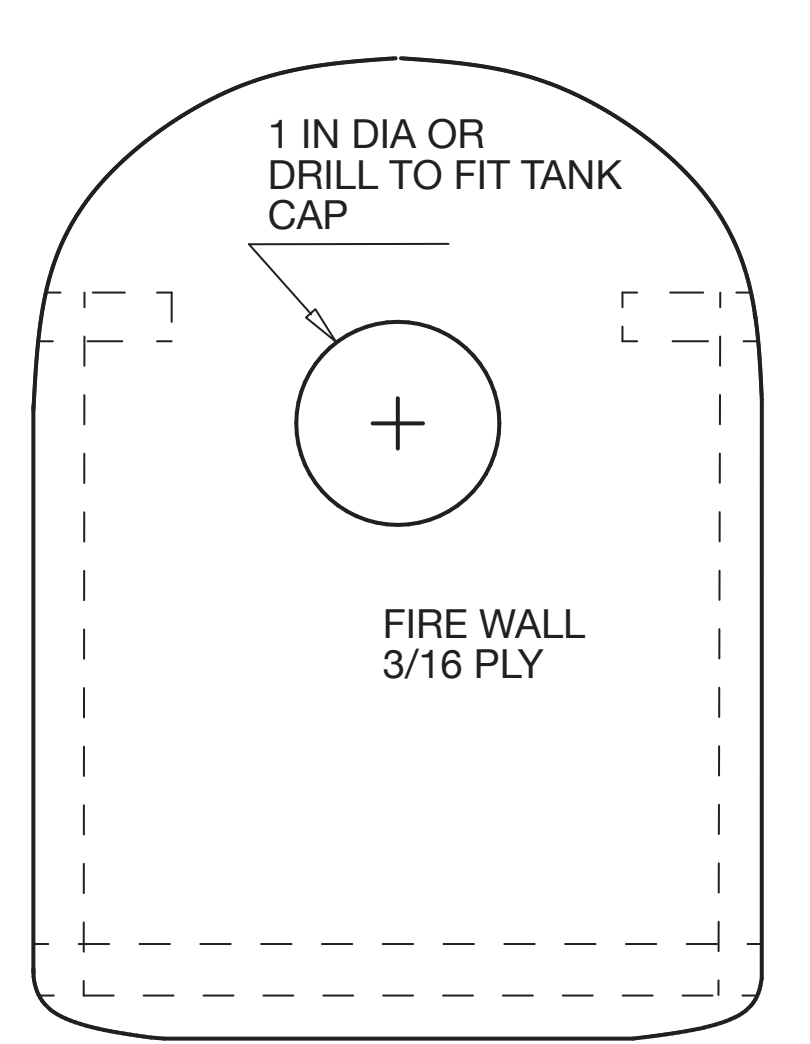

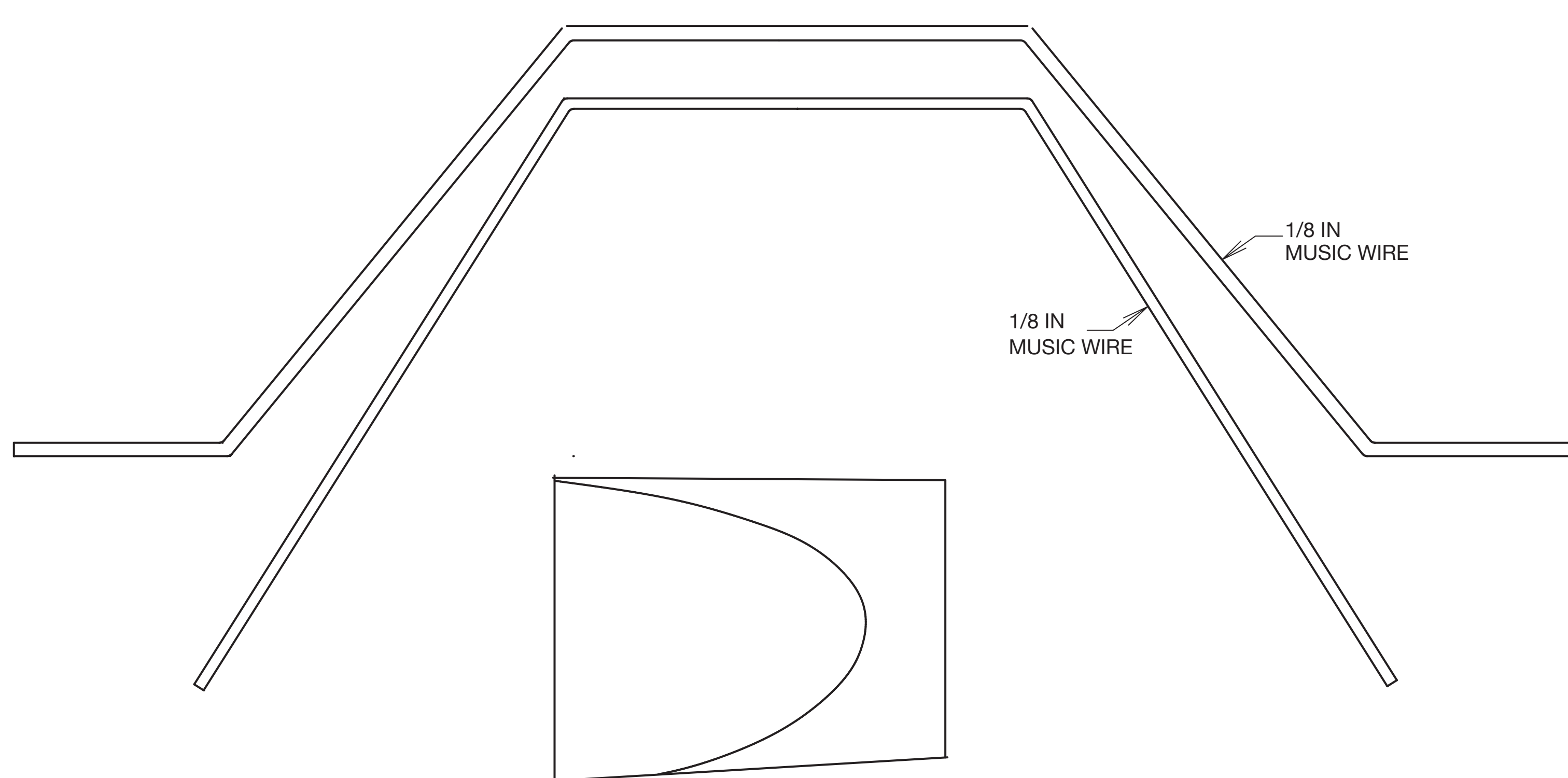
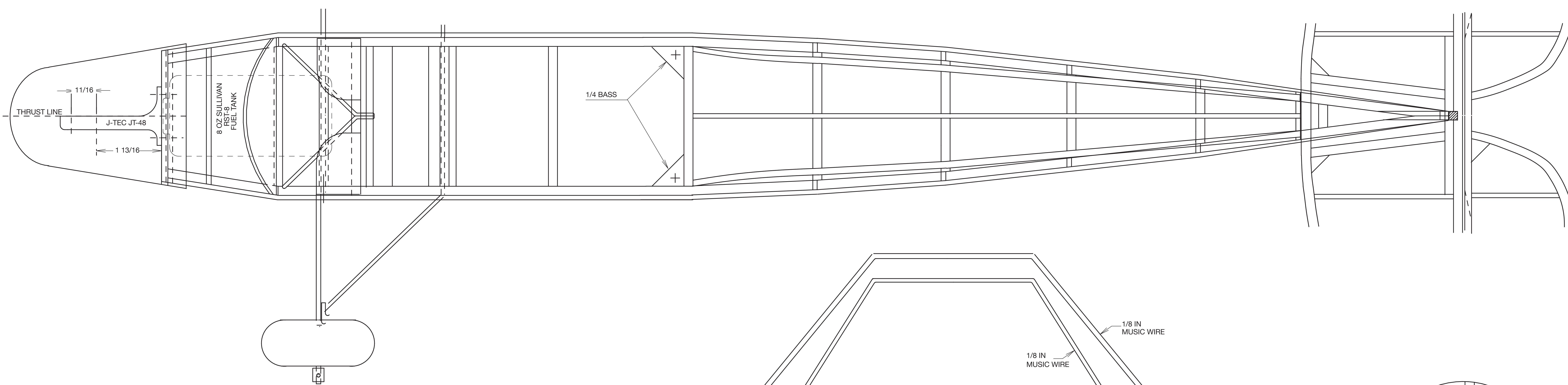