

VISTA LATO
INFERIORE

SEZIONE DERIVA
TIPICO

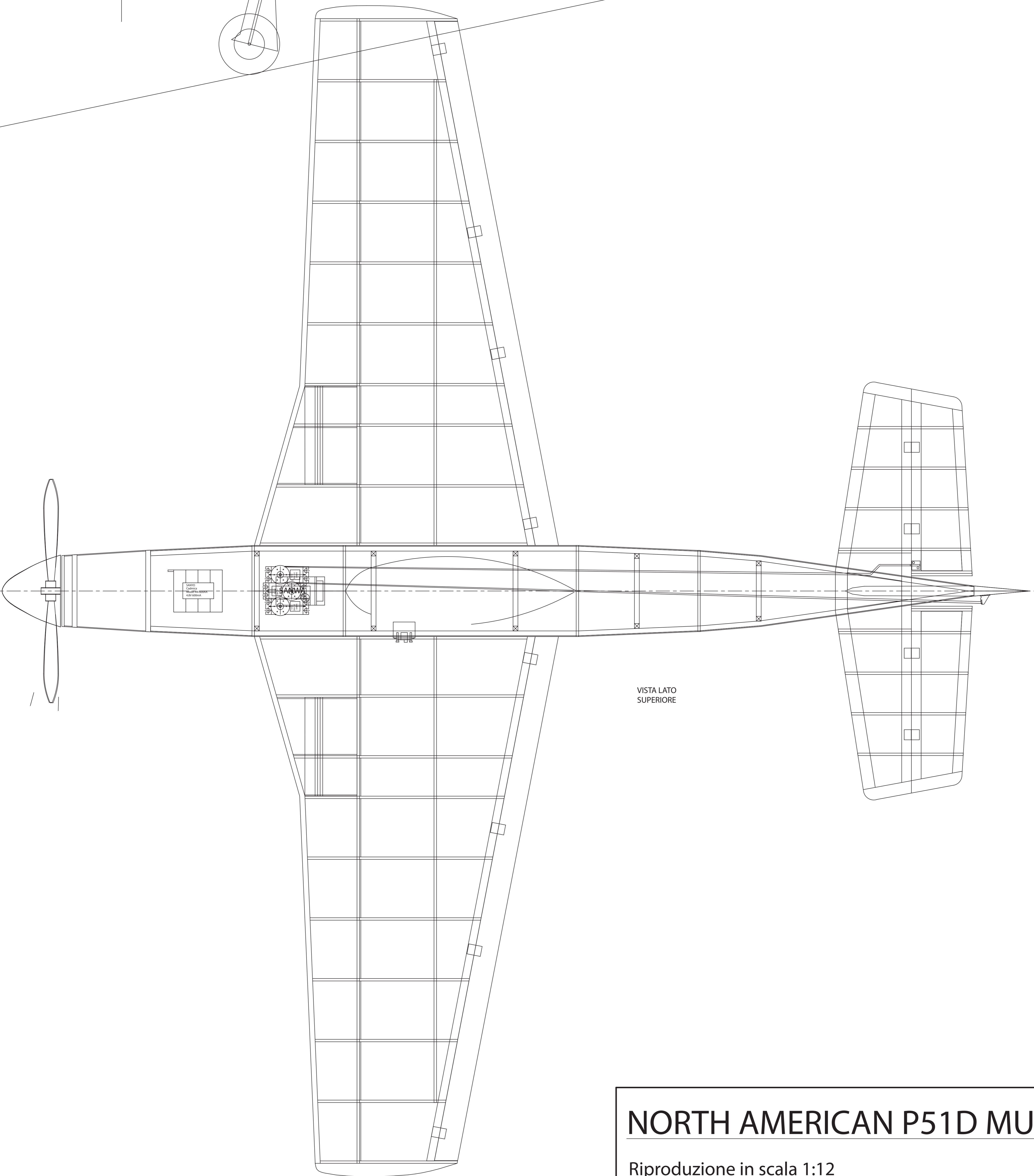
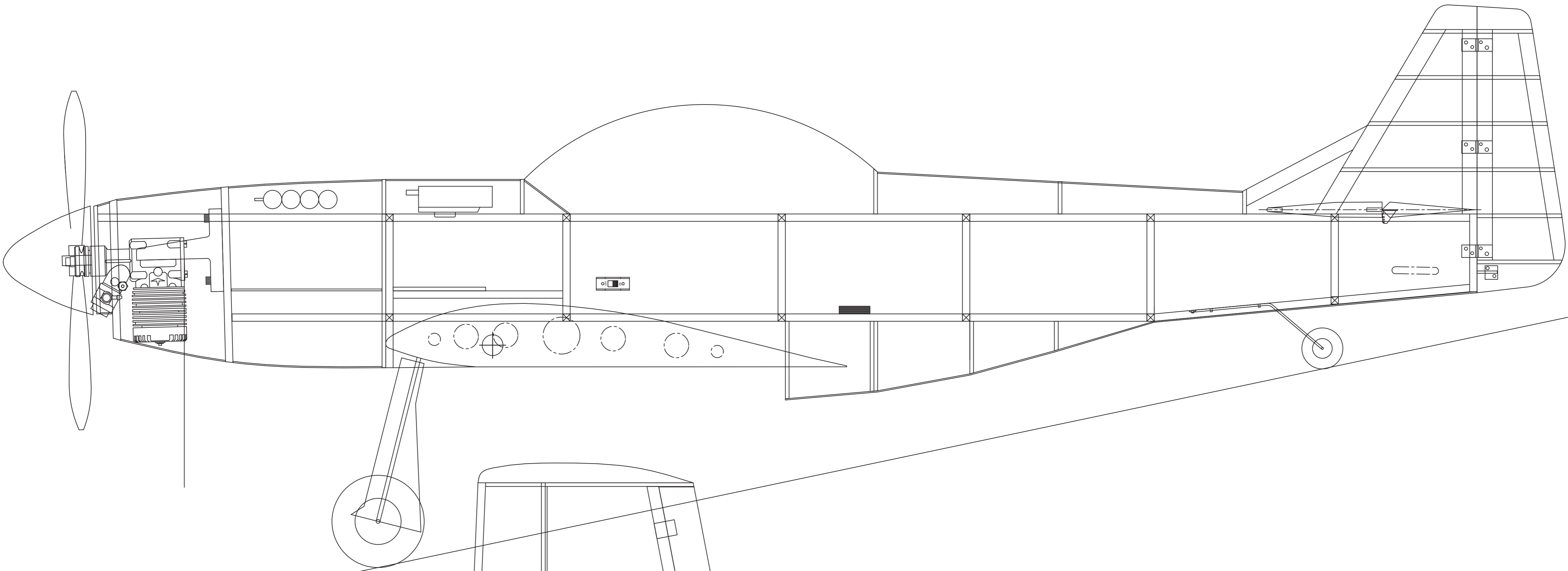
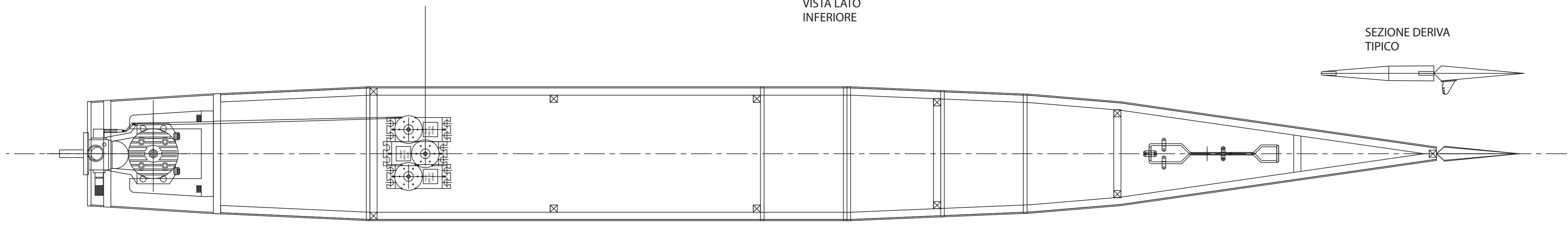

VISTA LATO
SUPERIORE

NORTH AMERICAN P51D MUSTANG

Riproduzione in scala 1:12

Foglio 1 di 3

Disegnato da: P.Pastorino il 21.12.99



Incollare e sagomare per formare l'estremità

SEZ. A-A

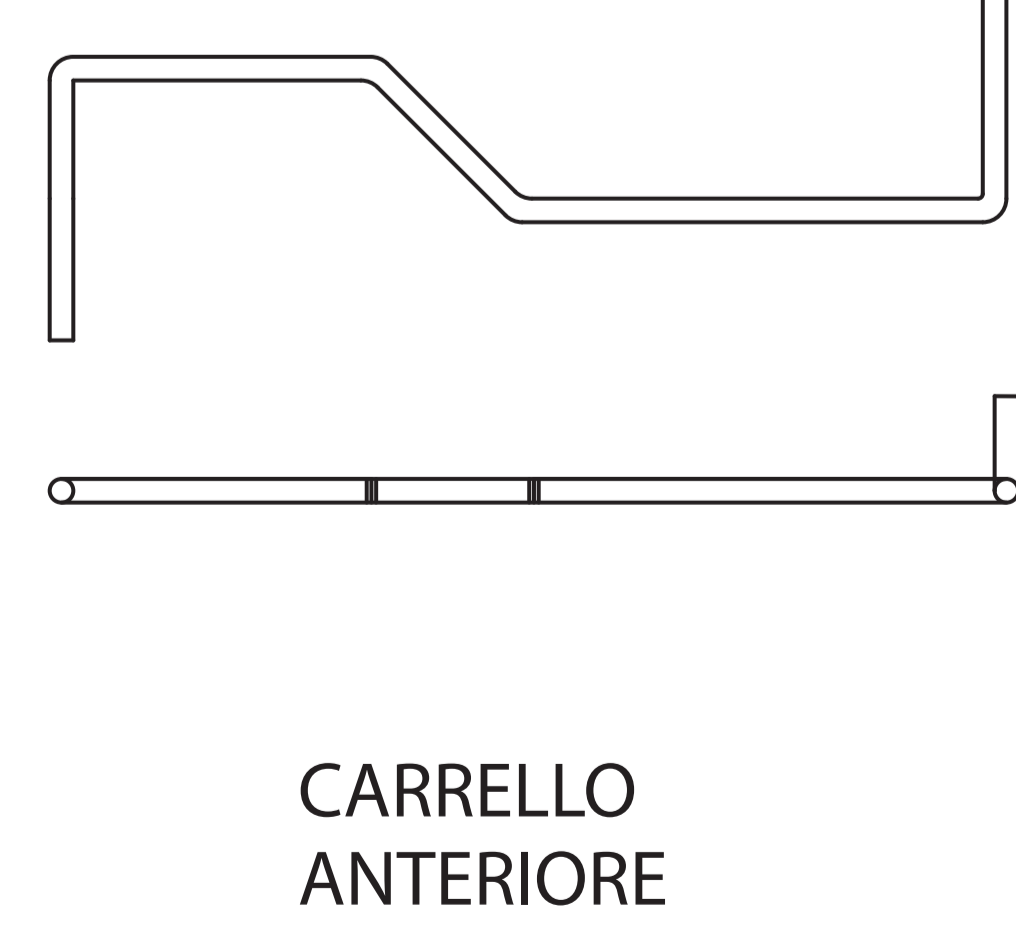
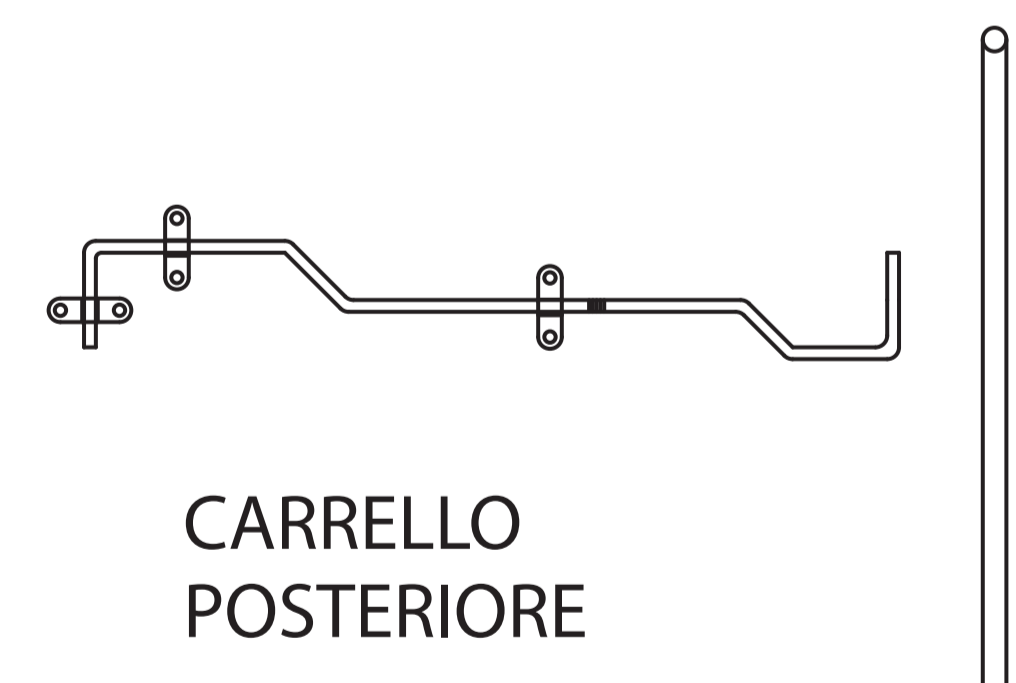
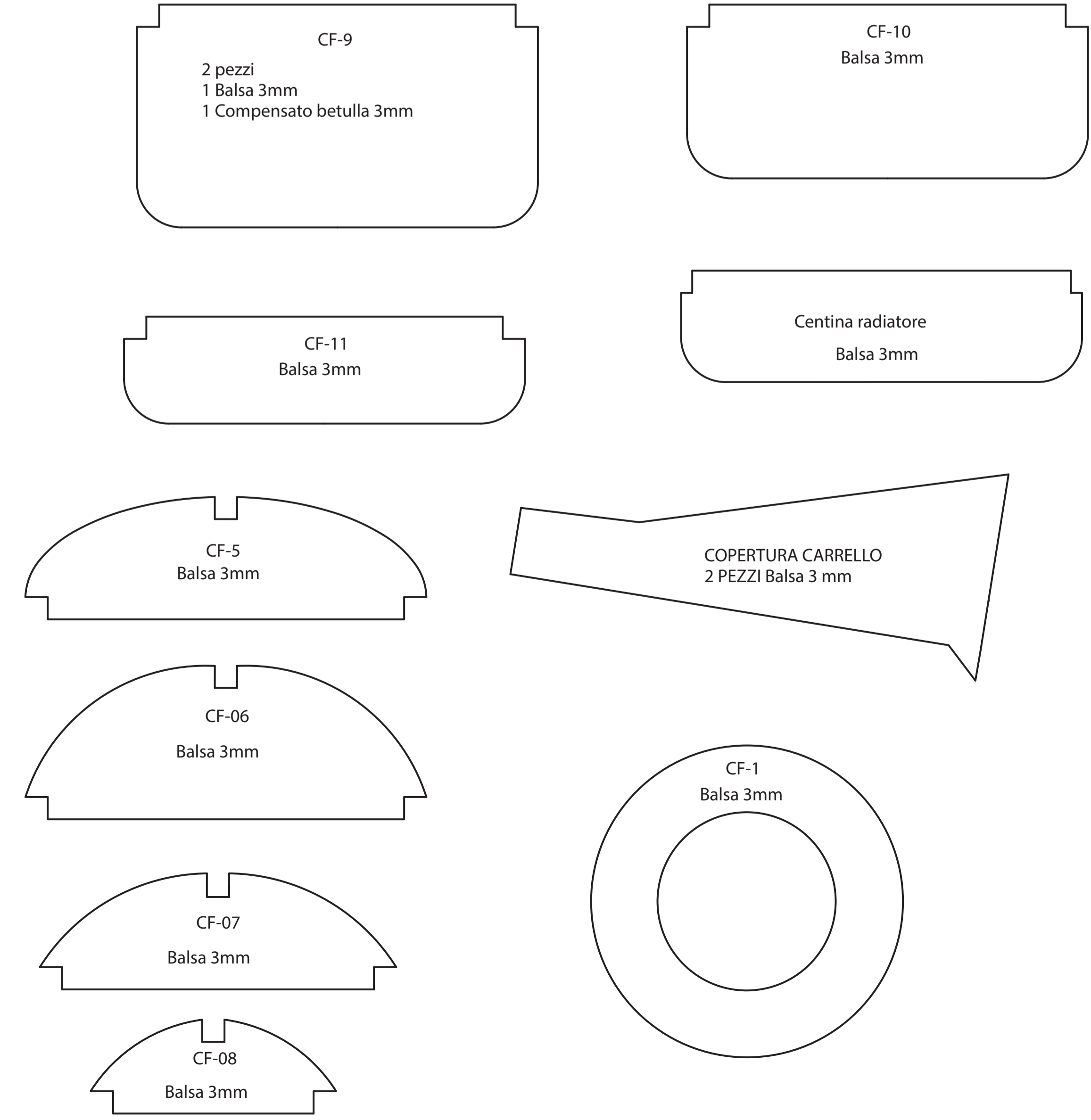

UNIONE ALI
VISTA LATERALE

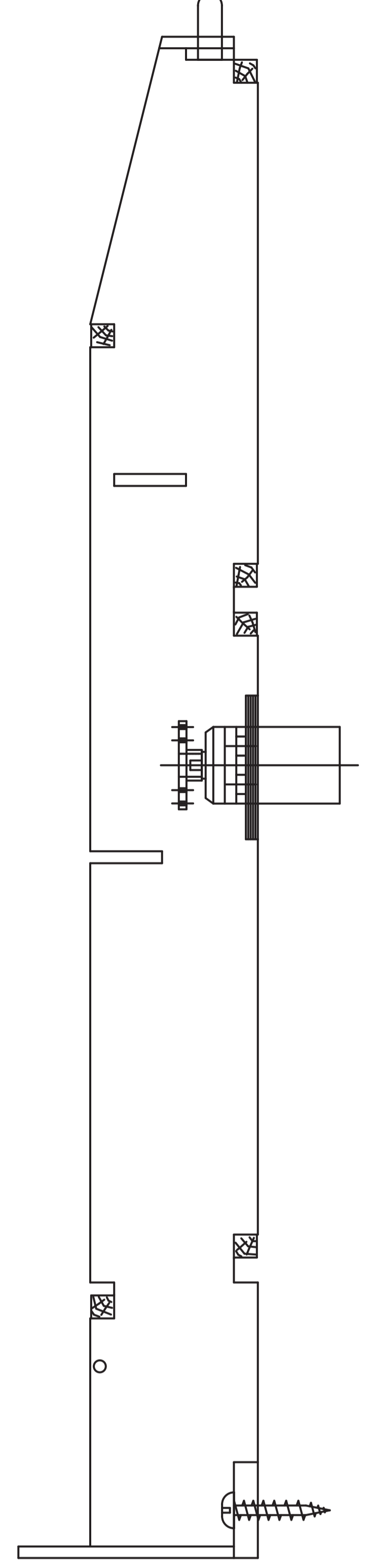

UNIONE ALI
VISTA SUPERIORE

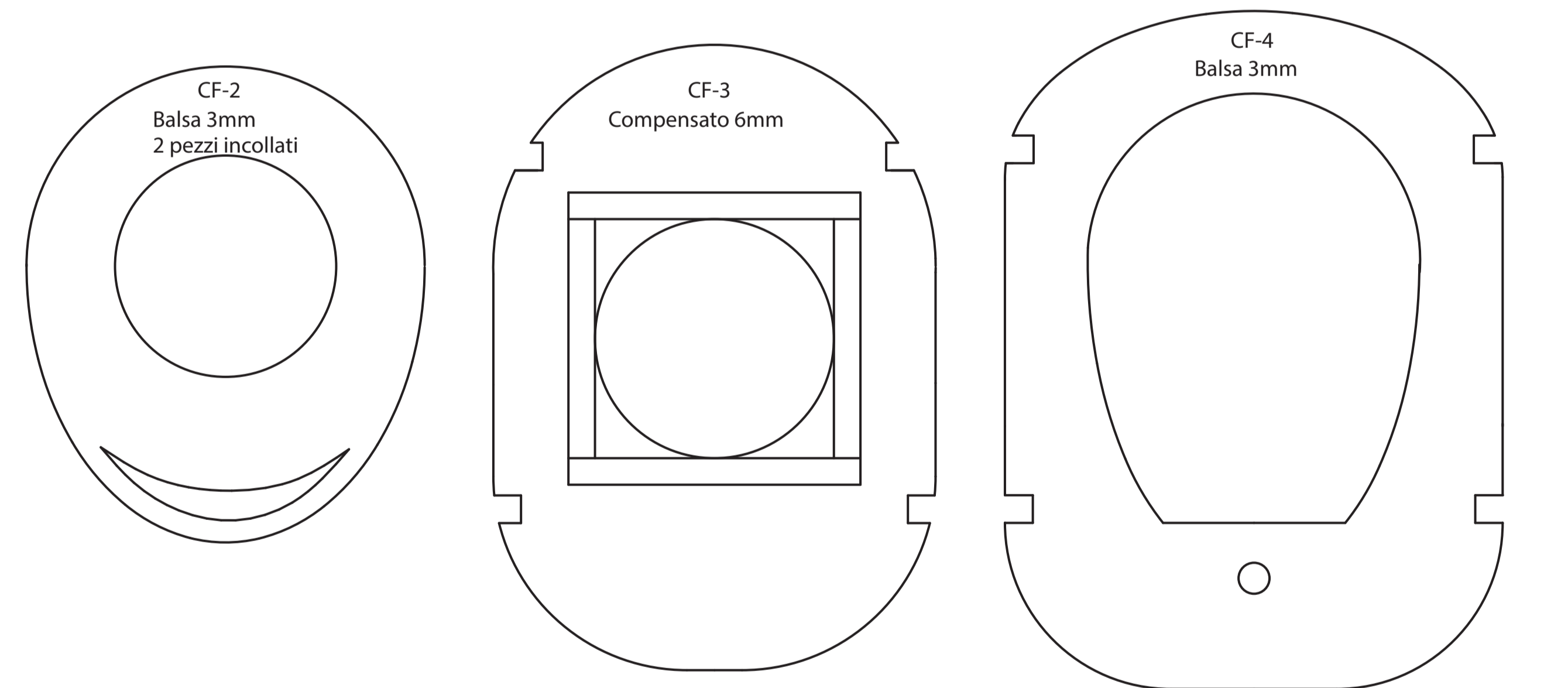
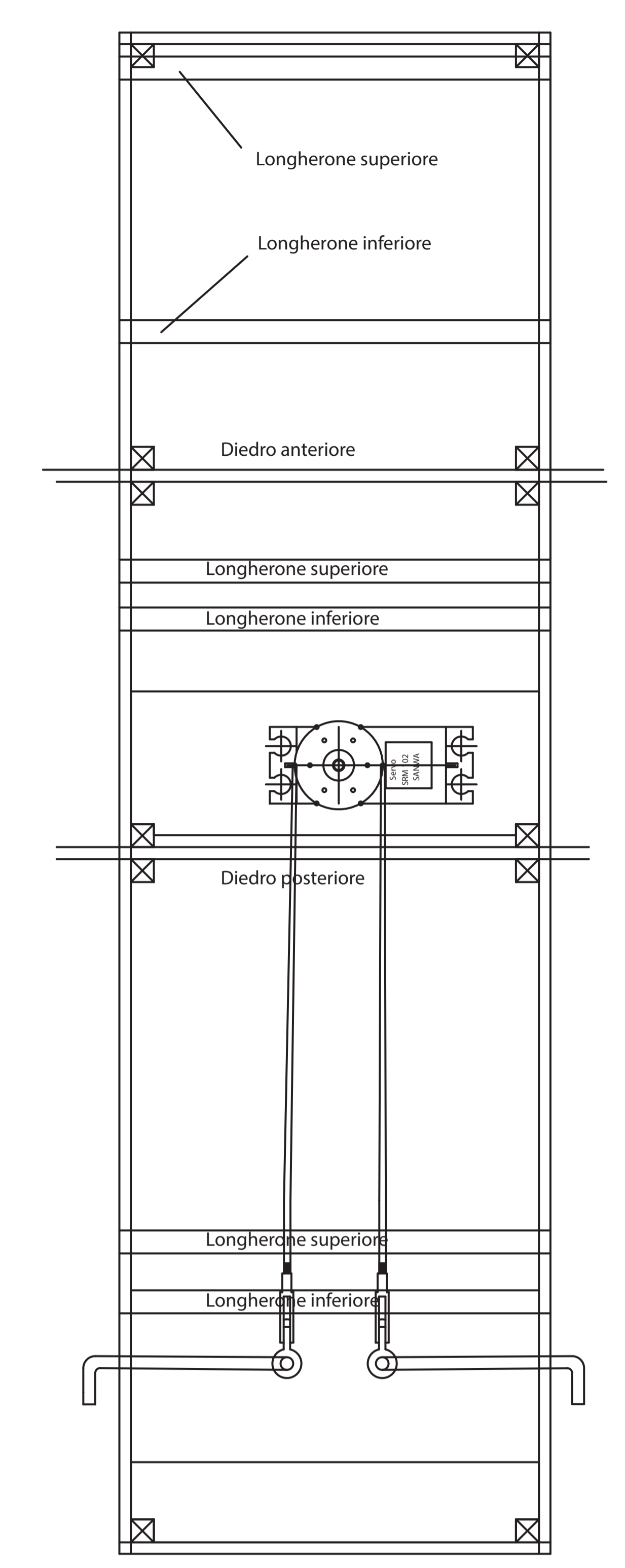

NORTH AMERICAN P51D MUSTANG

Riproduzione in scala 1:12

Foglio 2 di 3

Disegnato da: P.Pastorino il 21.12.99

ASSIEME CENTINA - TIPICO

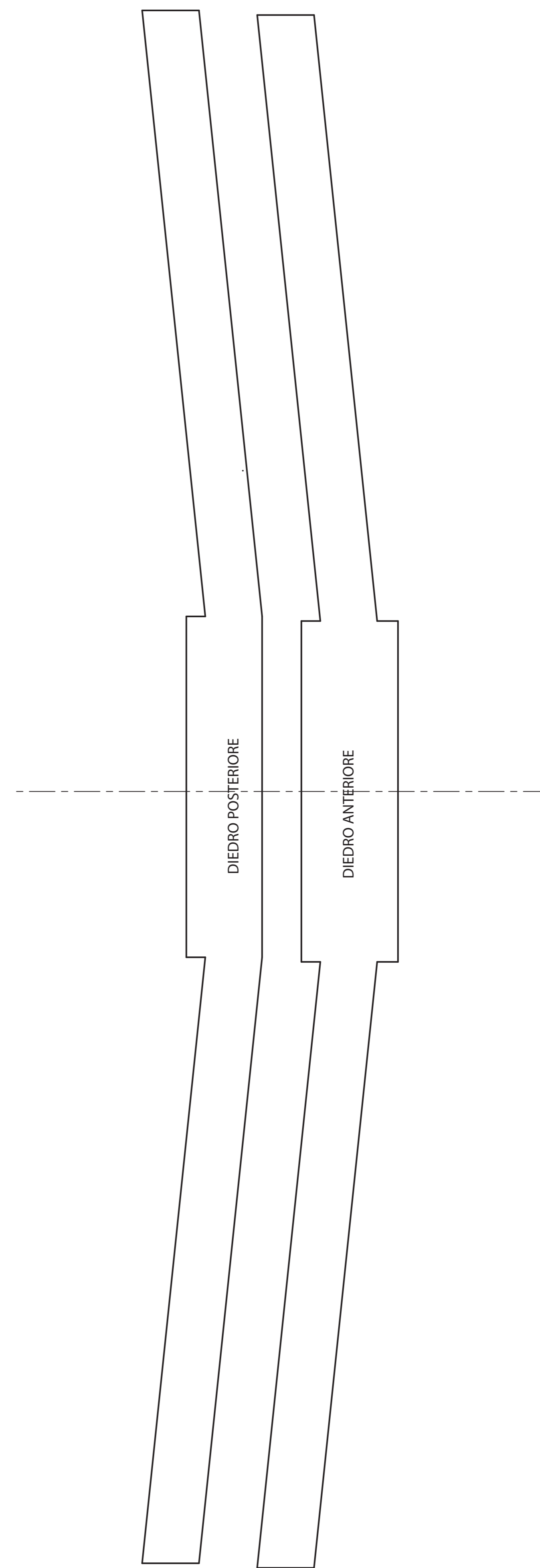
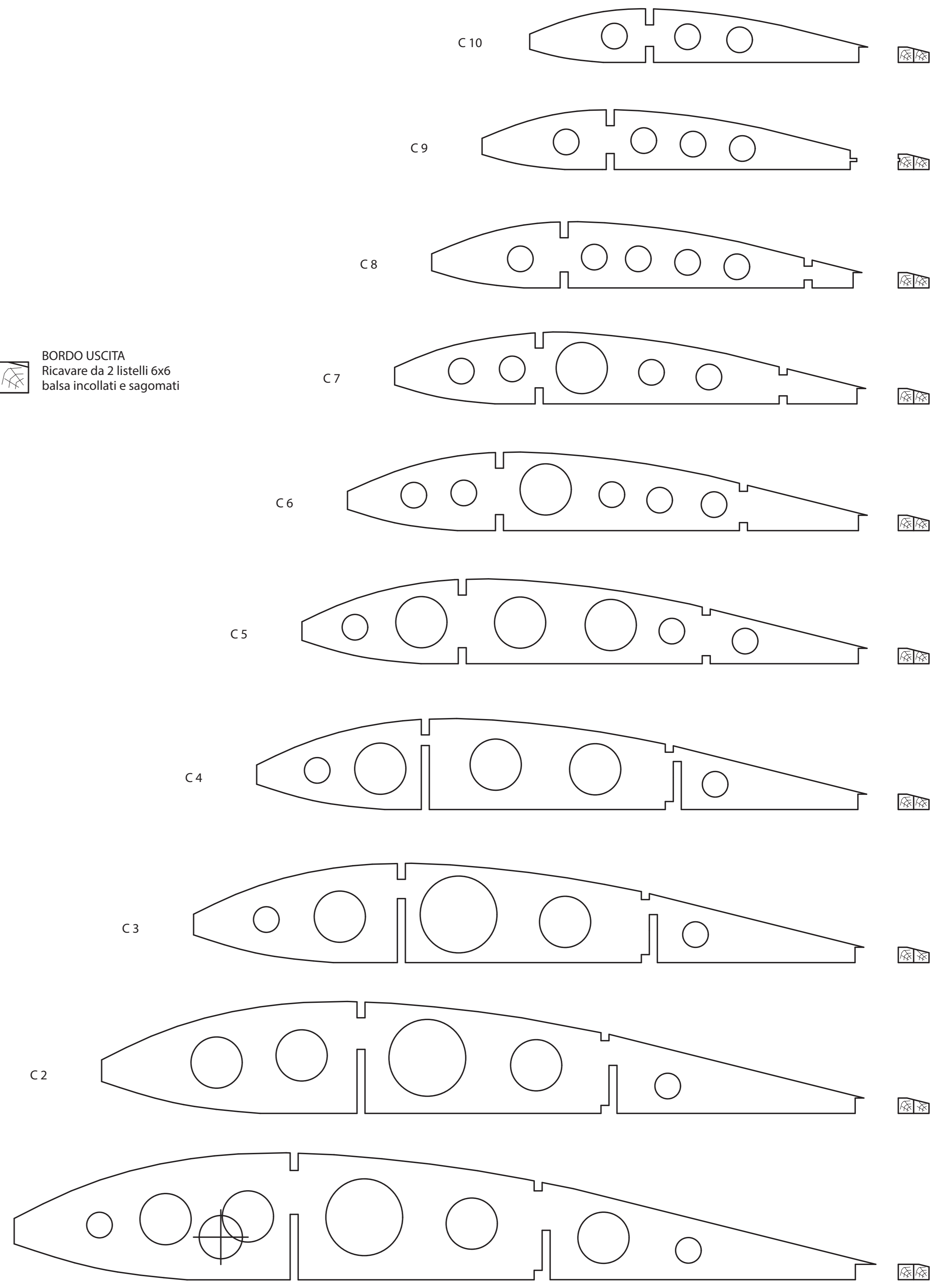
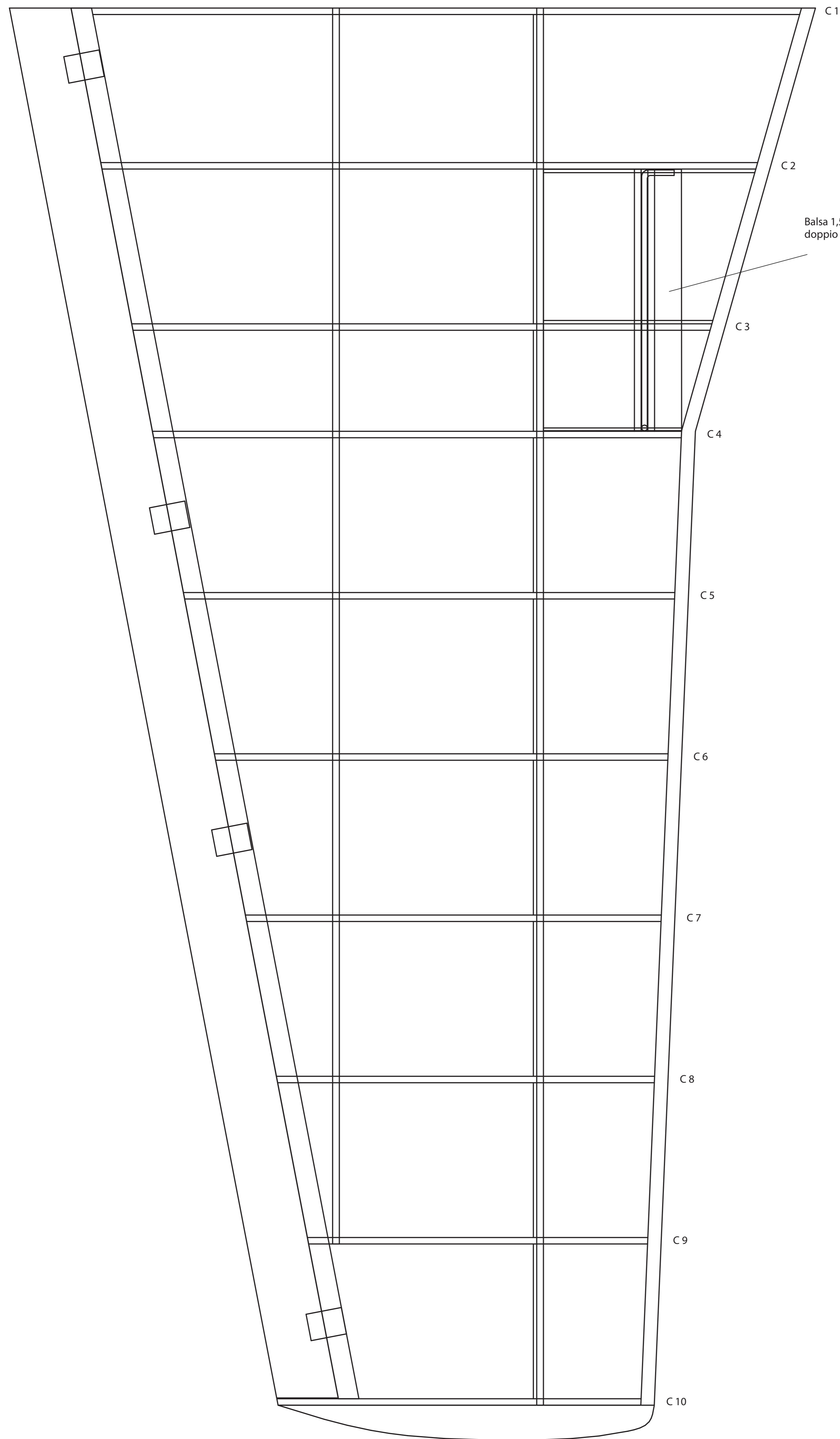
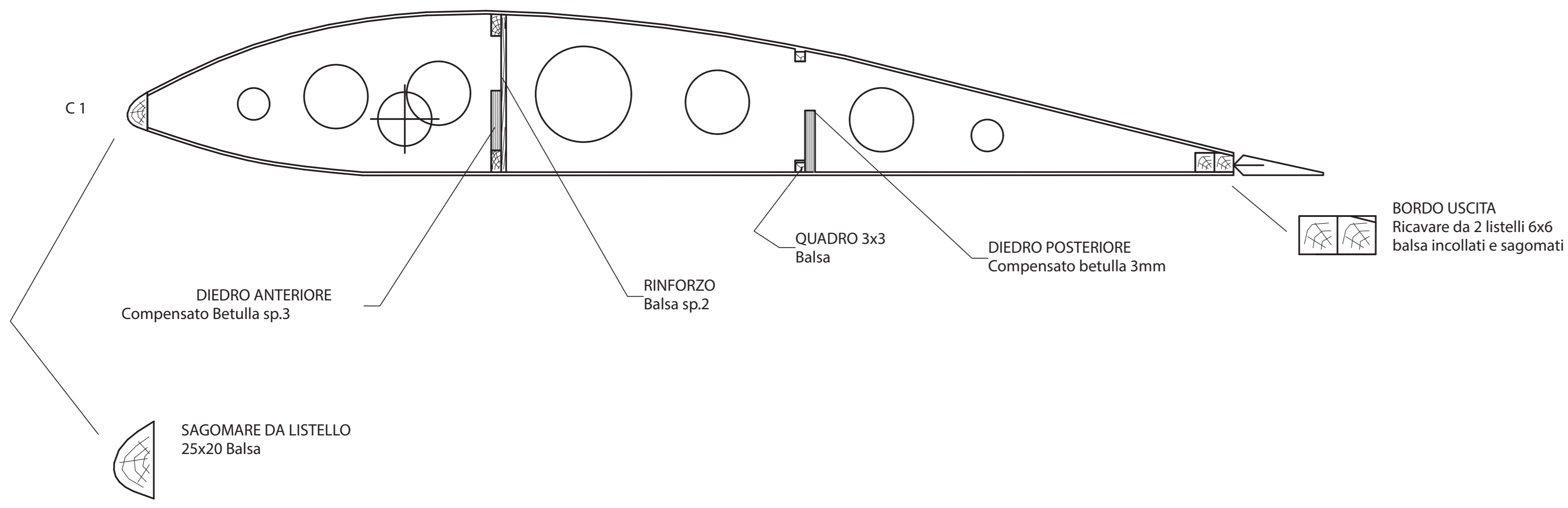

NORTH AMERICAN P51D MUSTANG

Riproduzione in scala 1:12

Foglio 3 di 3

Disegnato da: P.Pastorino il 21.12.99