

Elevator Cross Section - Typical

1" Right

Cut Out for Head Clearance

Upper Servo Tray

BOTTOM VIEW

TOP VIEW

Glue and Sand 1/4" scrap to form Tip

Tail Gear Template

Glue and Sand 1/4" scrap to form Tip

Glue and Sand 1/4" scrap to form Bottom

Form Cowling with 1/8X 1/4 Planking

1" Down

.60 Engine Shown

1/8" Light Ply

C.G.

Wing Hold Down Plate (2 - 1/8" light ply stacked)

1" Diam. Wheel

3" Diam. Wheel

L.G. Door Template 1/8" Ply

P-51-B PONY

Designed and Drawn by Norman E. Meyers

Wing Span 57 3/4 in. Length 50 3/4 in. Weight 6.2 lbs. Engine .40 to .61

These plans are offered free of any charge. No commercial use without written consent of the designer.

Fuselage

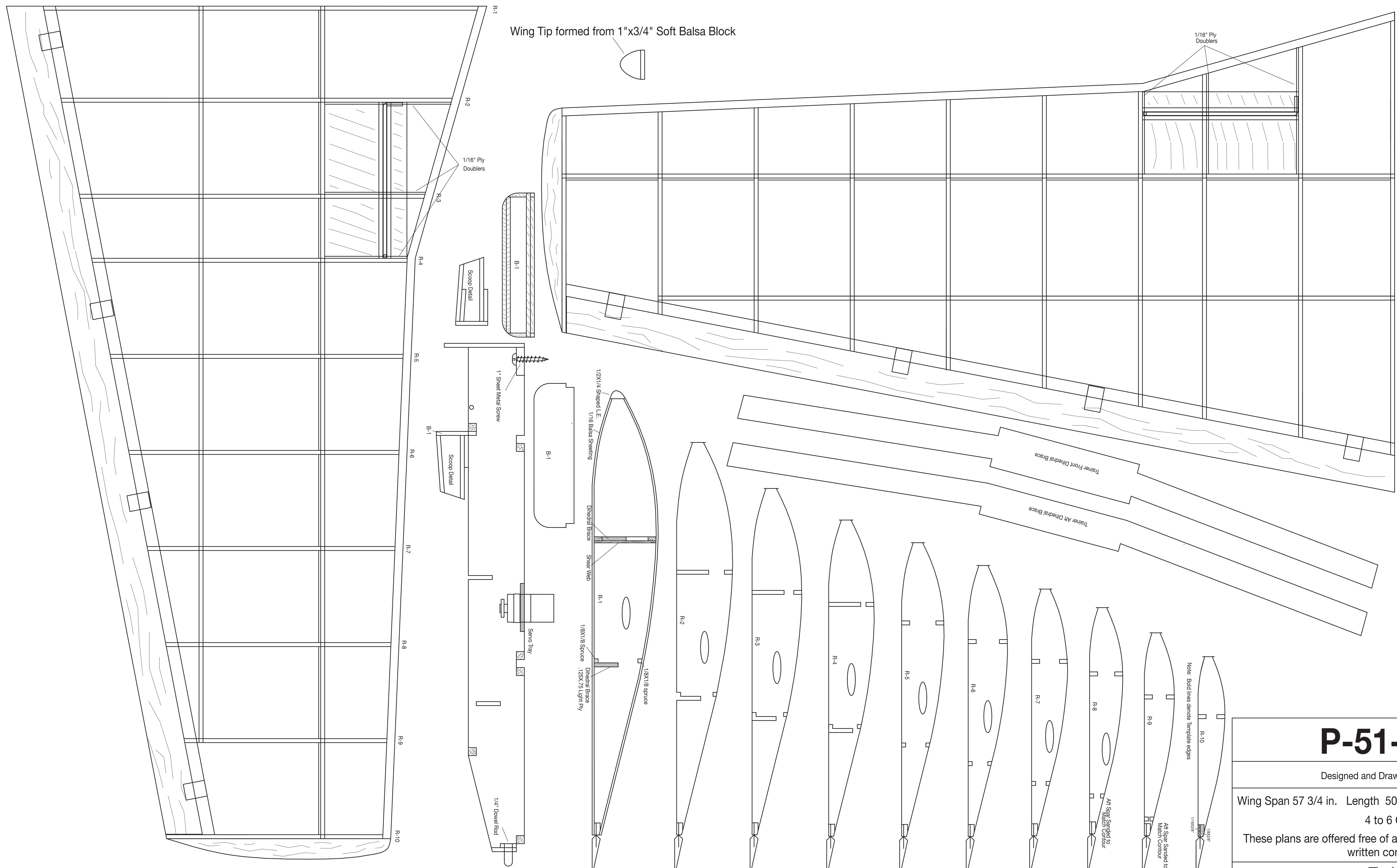

Wing Tip formed from 1"x3/4" Soft Balsa Block

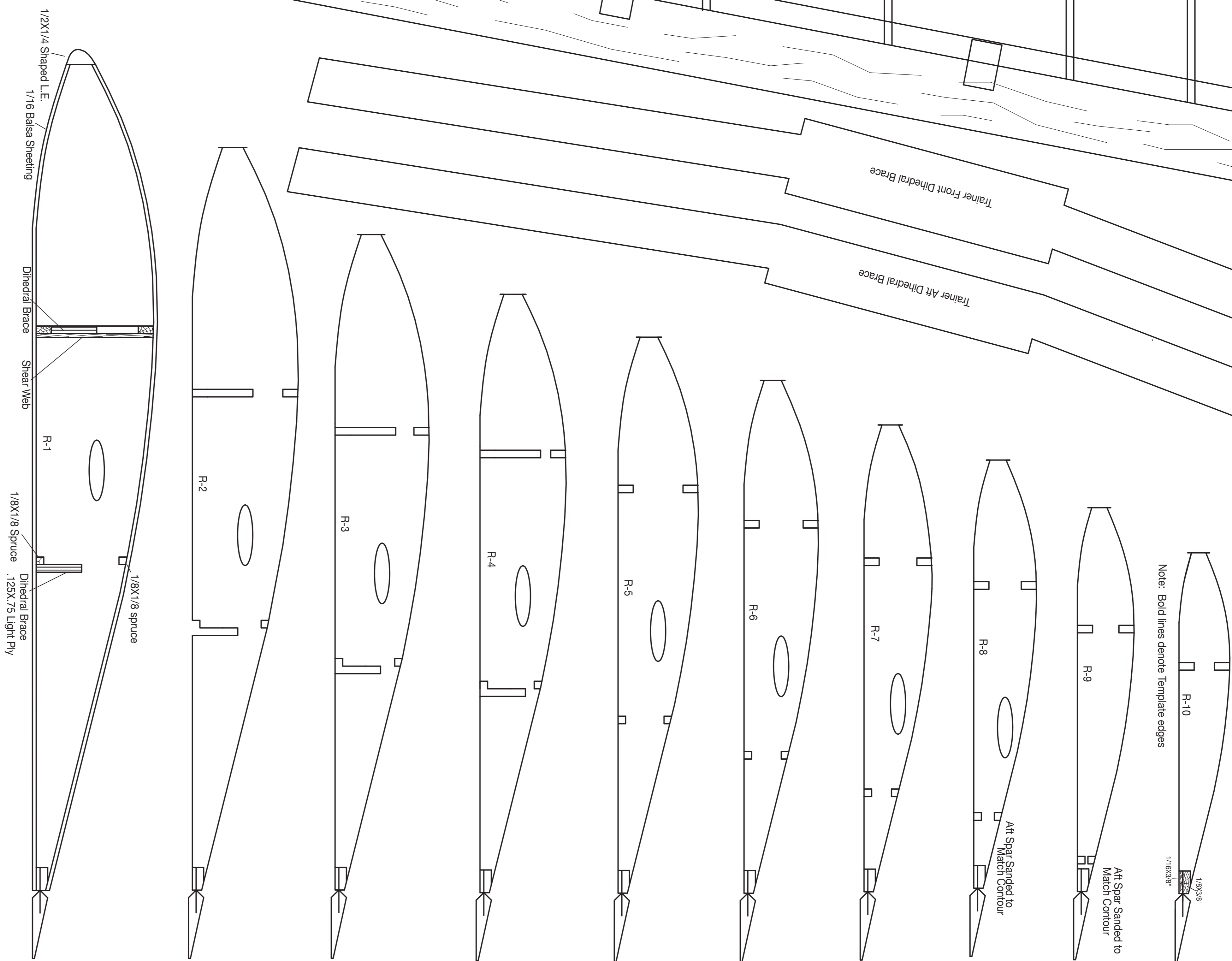
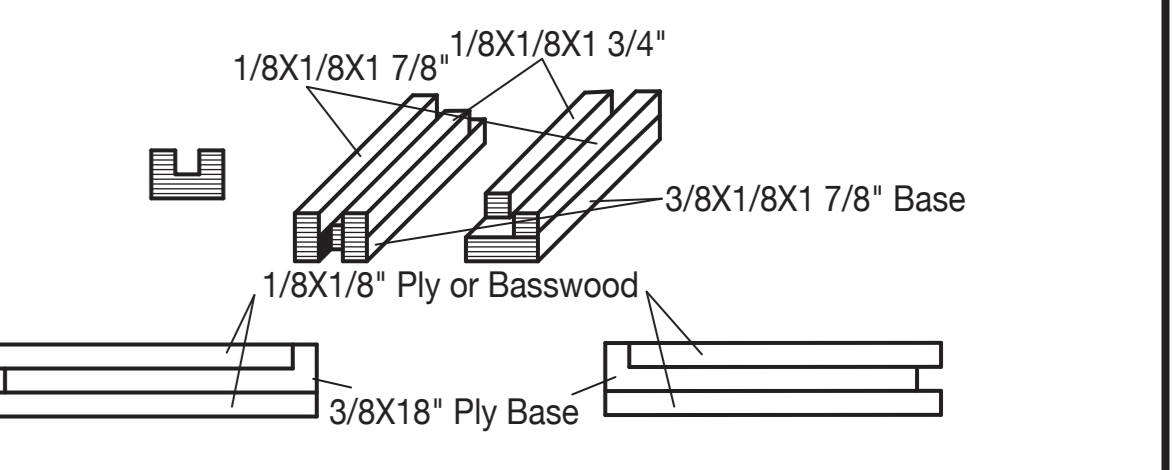
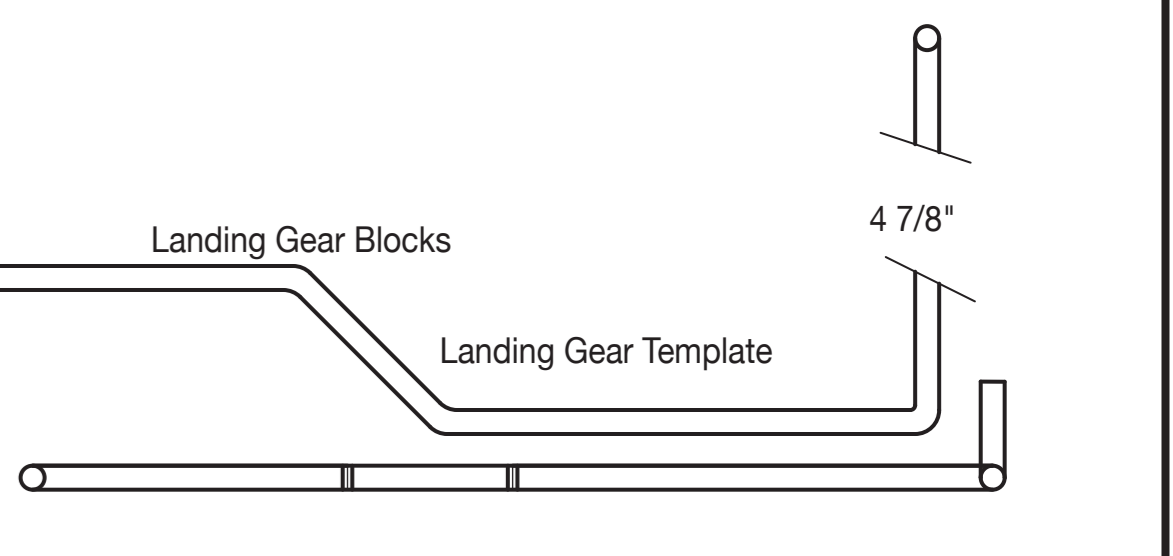
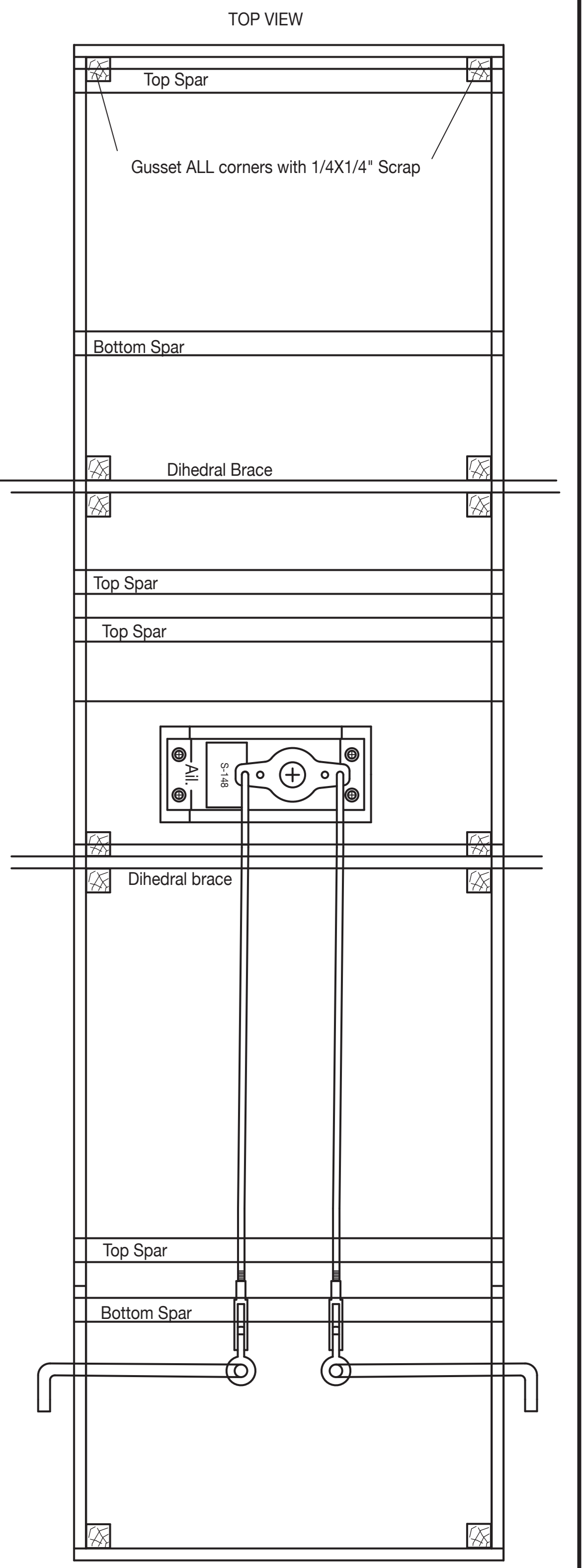

Note: Bold lines denote template edges
 At Spar Sanded to Match Contour
 At Spar Sanded to Match Contour

P-51-B PONY

Designed and Drawn by Norman E. Meyers

Wing Span 57 3/4 in. Length 50 3/4 in. Weight 6.2 lbs. Engine .40 to .61

4 to 6 Channel System

These plans are offered free of any charge. No commercial use without
written consent of the designer.

Trainer Wing