

Add long tabs to bottom of ribs.
 Use these to rest the trailing edge on when gluing up.
 This helps support and align the trailing edge.
 When dry and removed from board, trim off tab.
 Add these to remaining ribs.

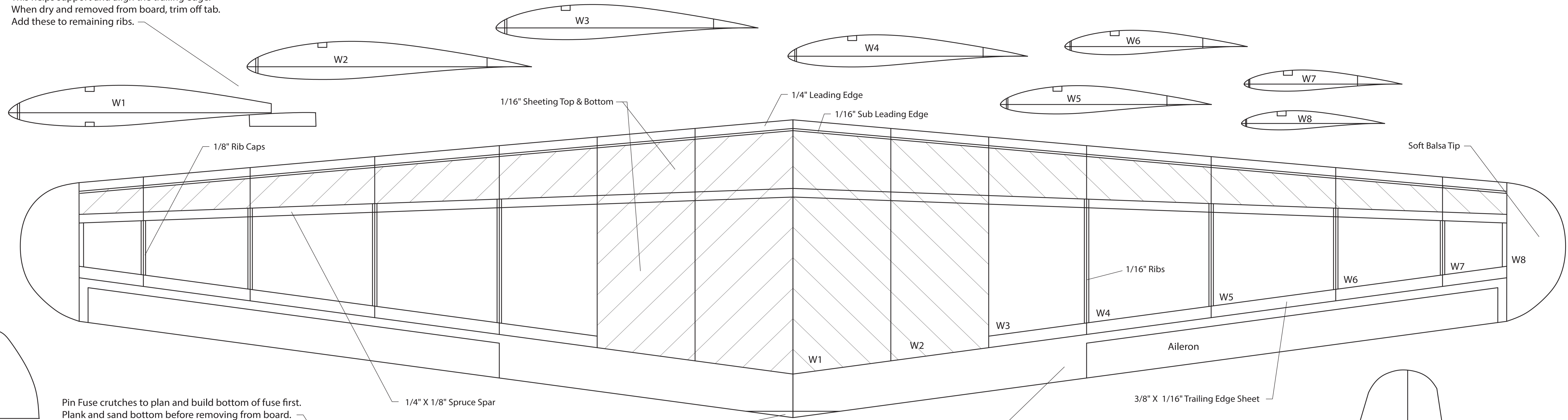

Pin Fuse crutches to plan and build bottom of fuse first.
 Plank and sand bottom before removing from board.

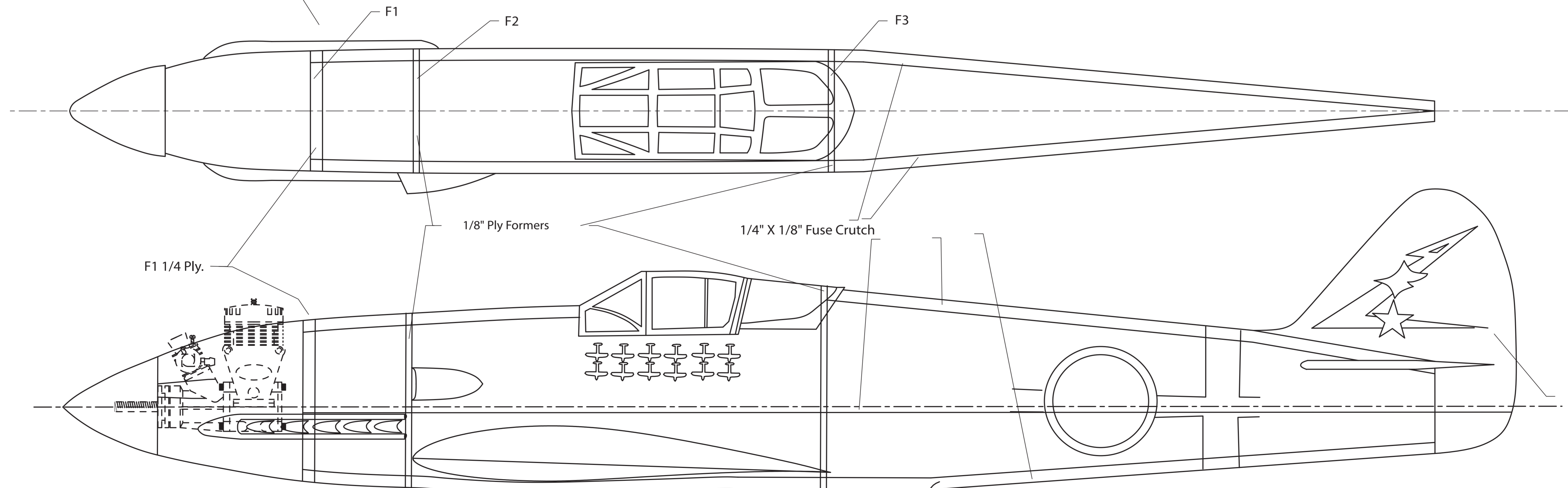
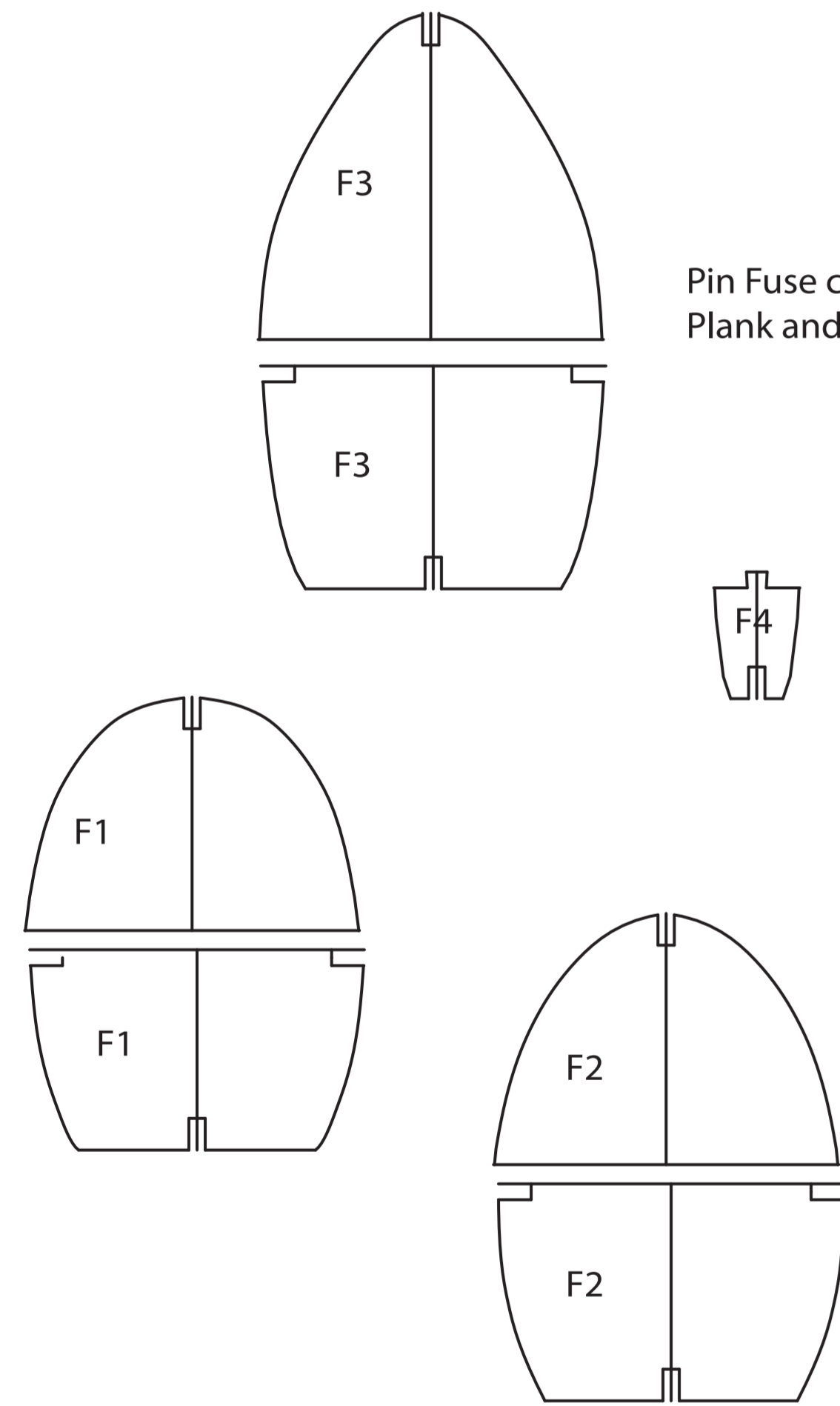

Sheet Fuselage with 1/16" balsa

Fuse Crutches cut from plan and paste to 1/8" board to cut out and pin to building board.

Kawasaki Ki 61 Hien
 Designed for RCCA 2610 rules
 Wing Span 43 3/8"
 Wing Area 260 sq. in. approx.
 Engine .15 - .26

Drawn by Nels Hogberg
 dhogberg@aol.com