

RIBS

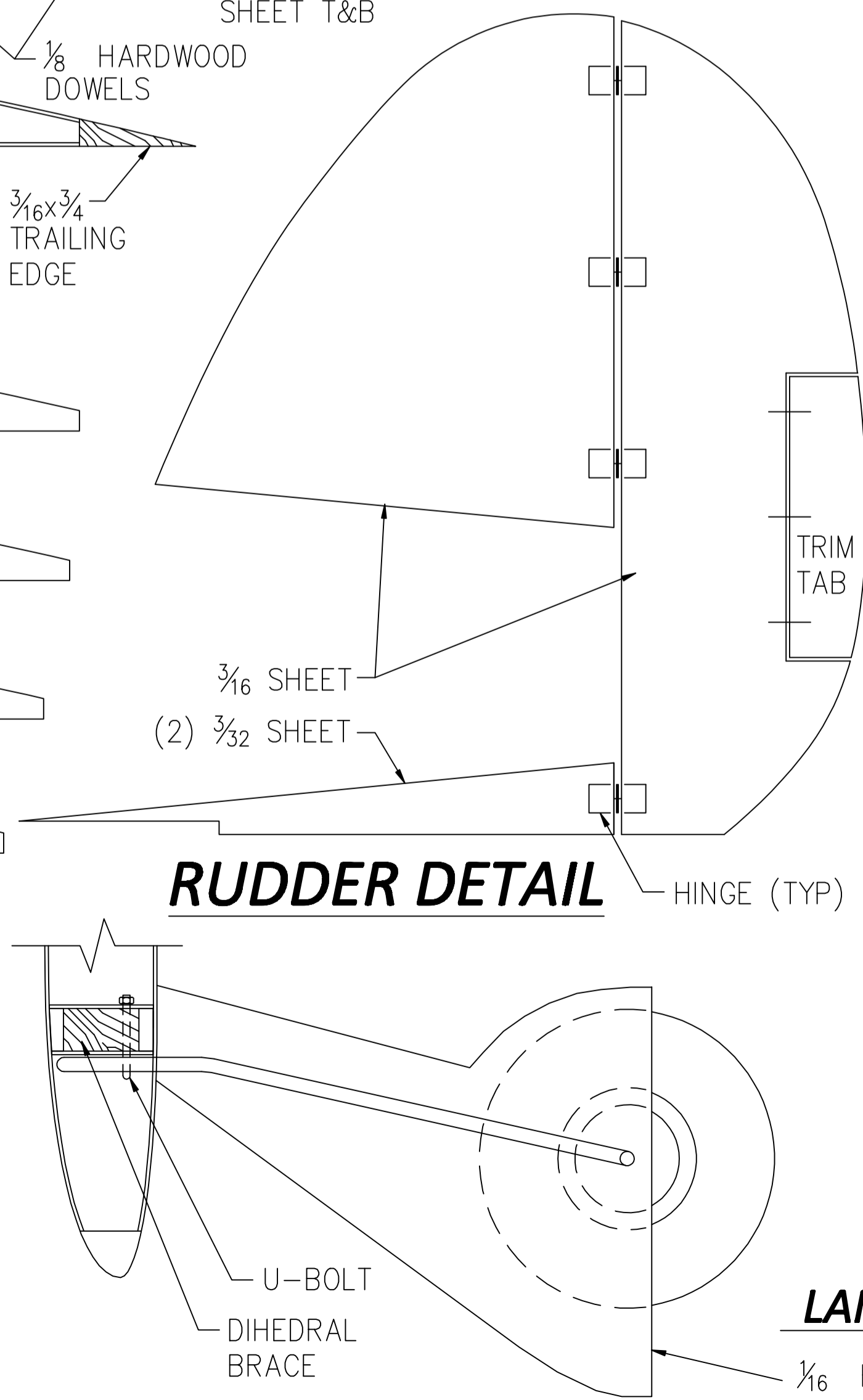

RUDDER DETAIL

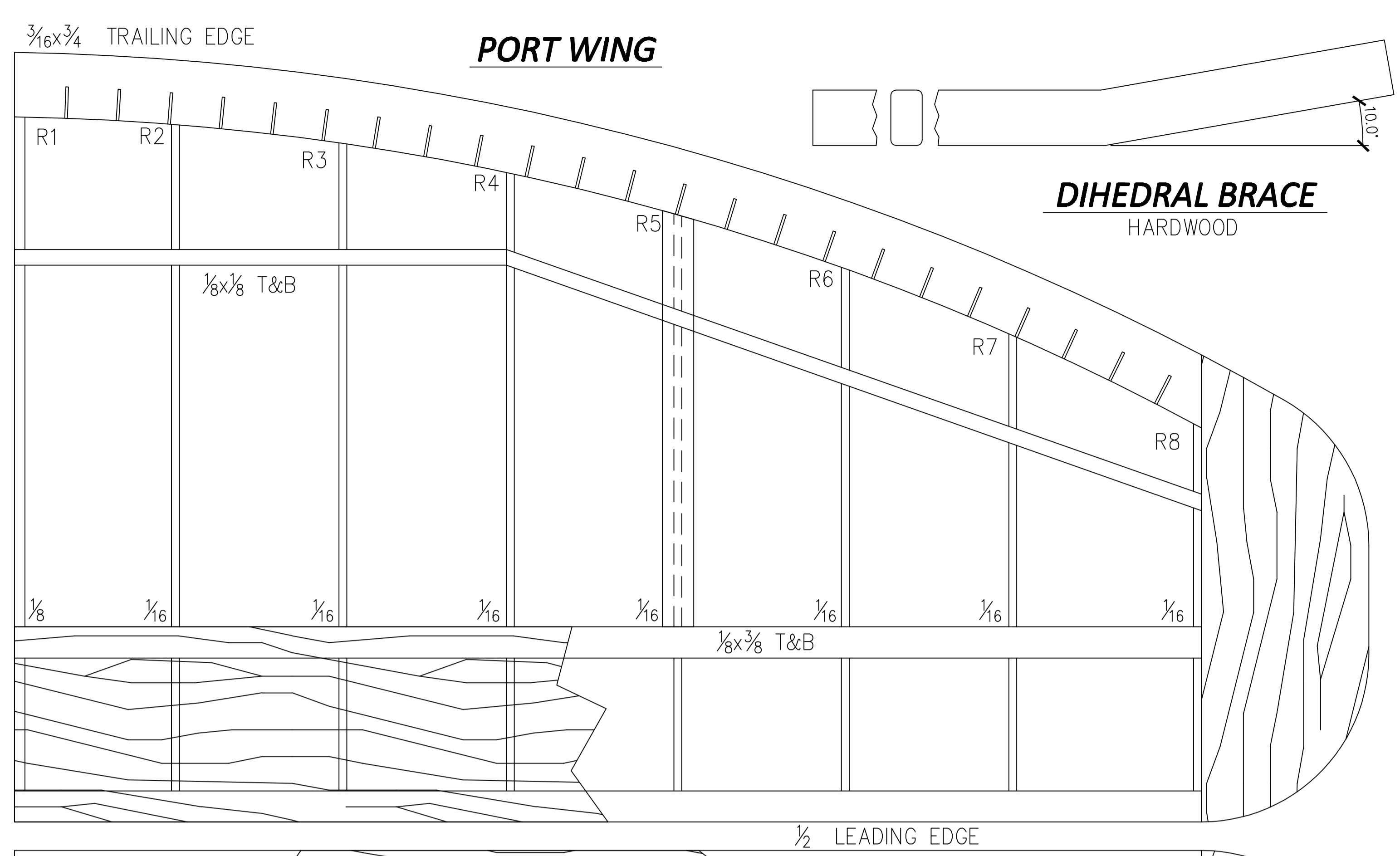

DIHEDRAL BRACE
HARDWOOD

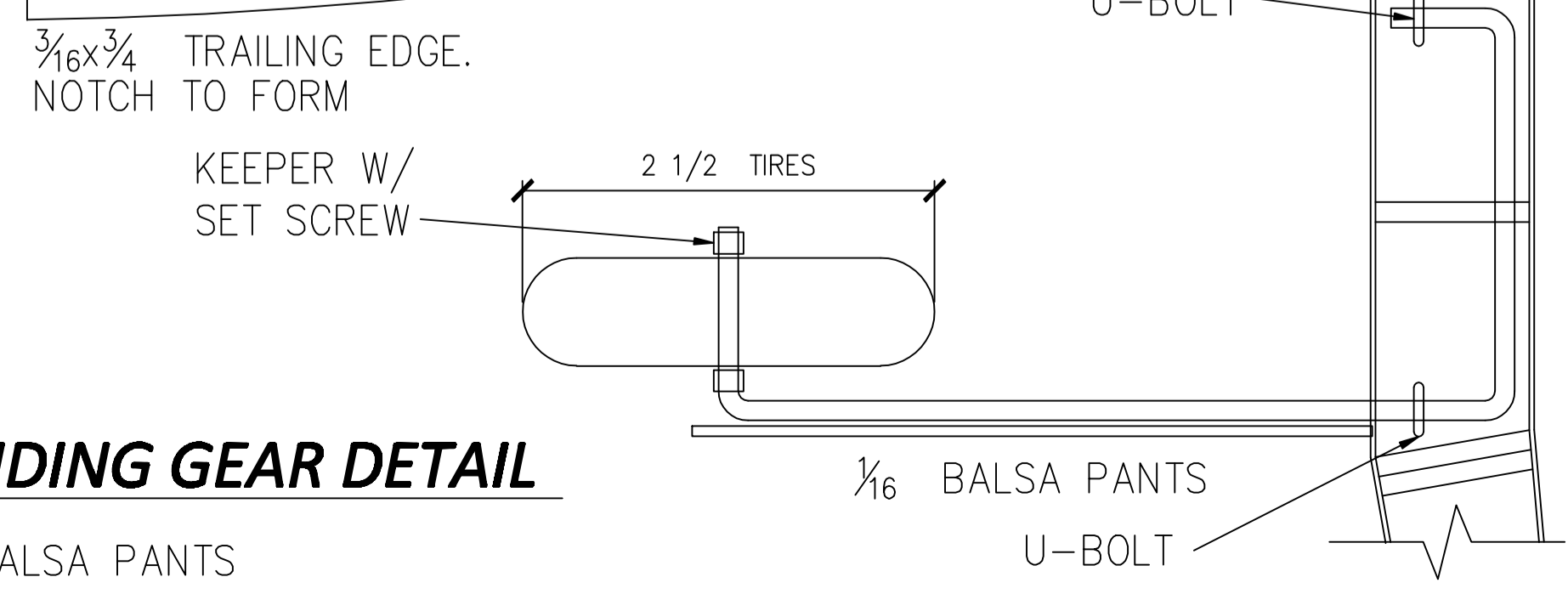
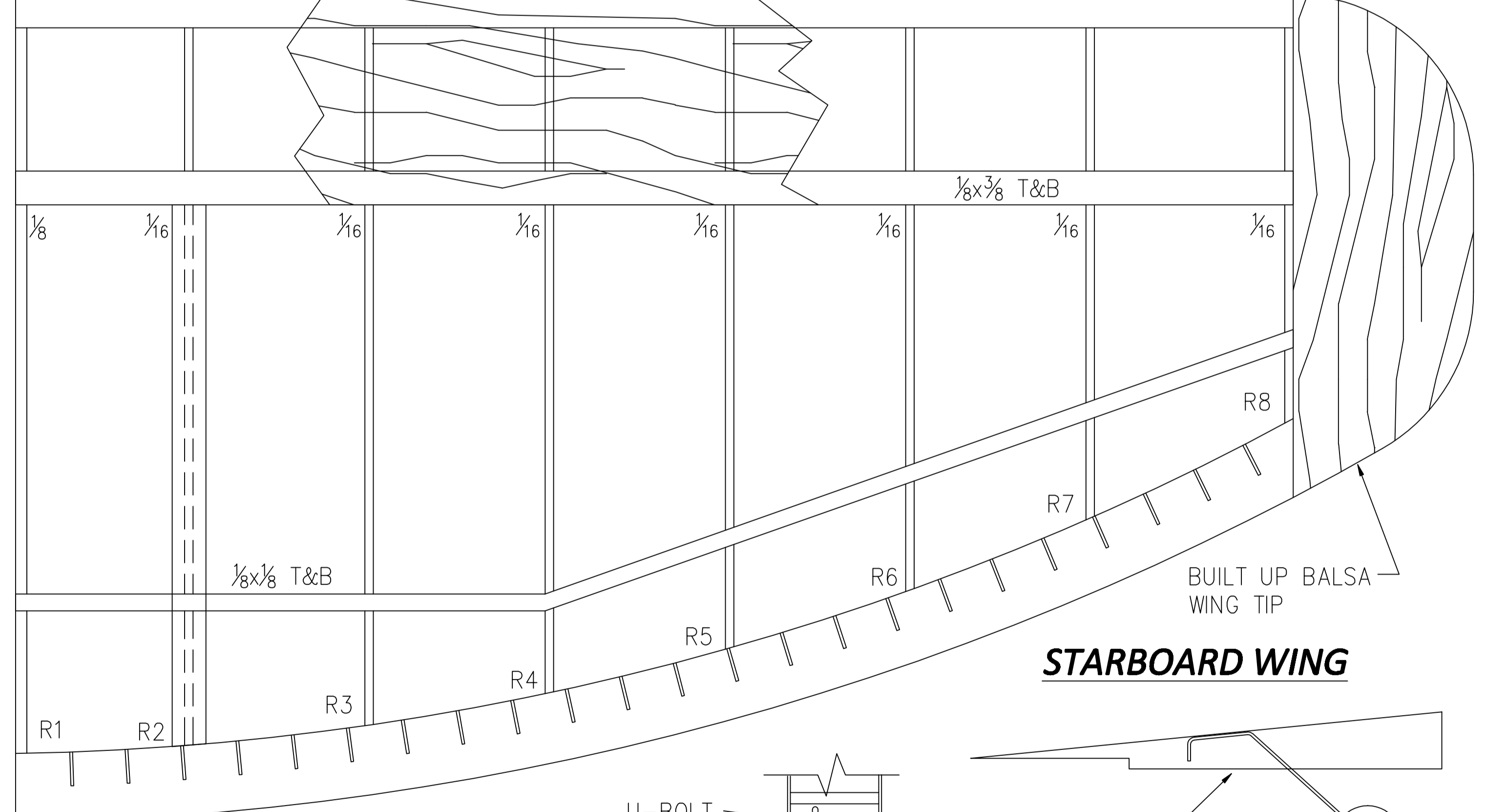

LANDING GEAR DETAIL

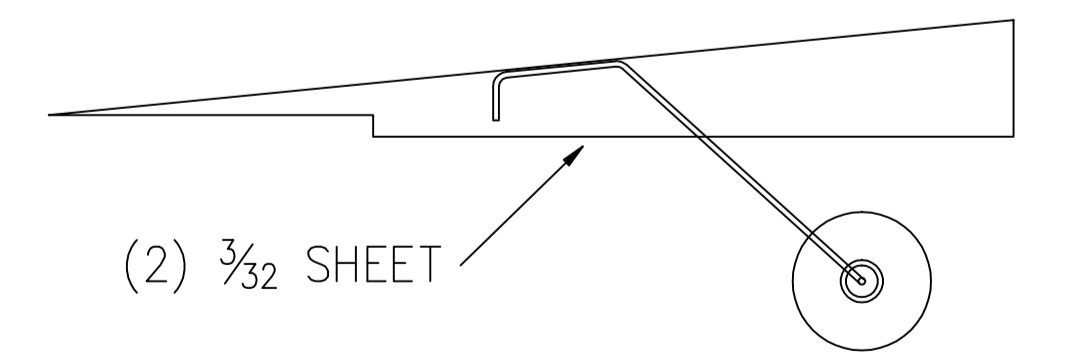

TAIL WHEEL DETAIL

Hawker Tempest Mk-1
WING DETAILS
 Wing Span - 48
 Wing Area - 387 sq in
 Length - 35
 Est. Weight 30 oz - Wing Loading - 11.1 oz/sq ft
 Adapted by - Old Pilot

Hawker Tempest Mk-1

3-VIEW

Wing Span - 48
Wing Area - 387 sq in
Length - 35
Est Weight - 30 oz Wing Loading = 11.1 oz/ft²
Adapted by Old Pilot Page 3 of 3

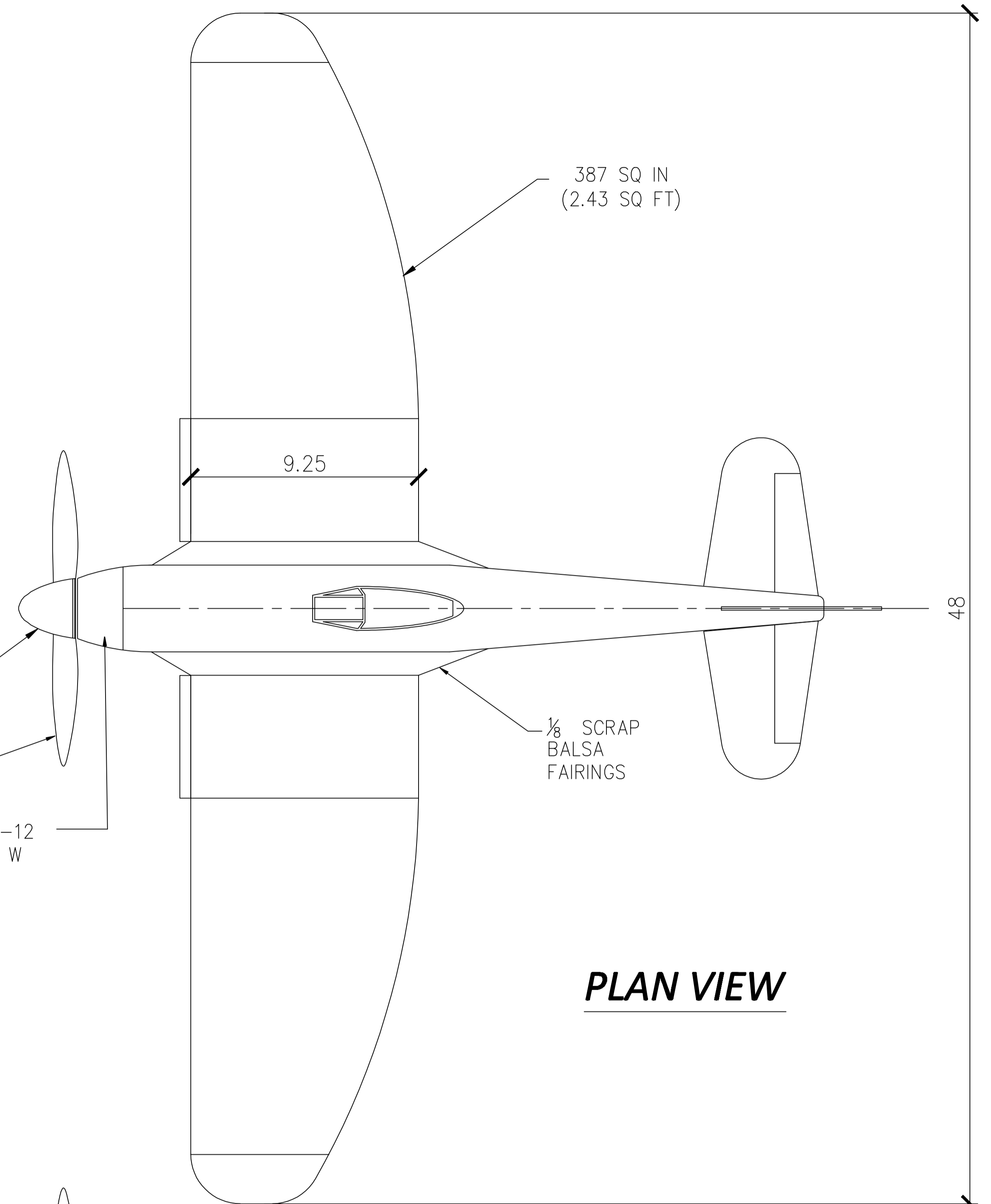
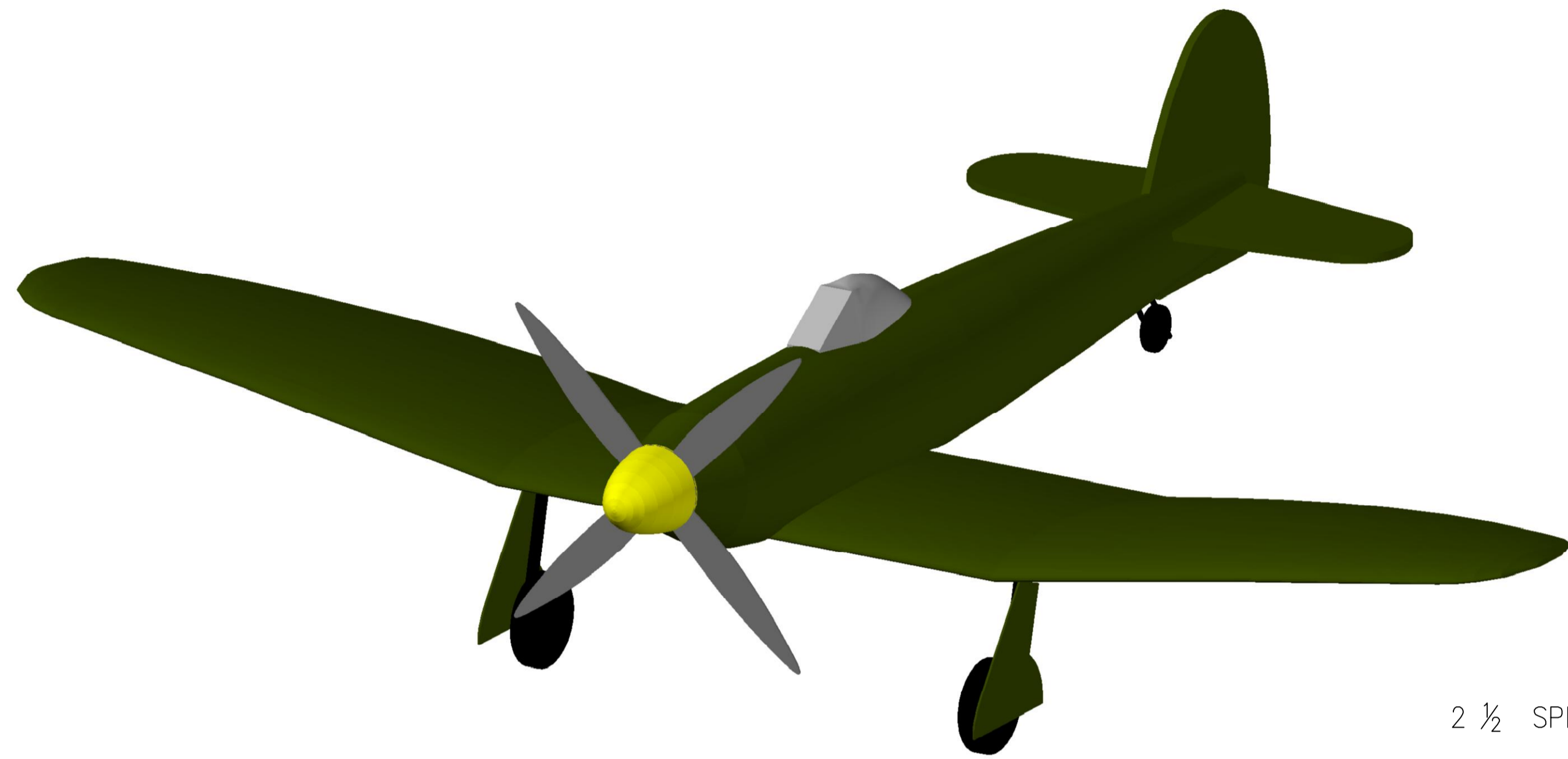

PLAN VIEW

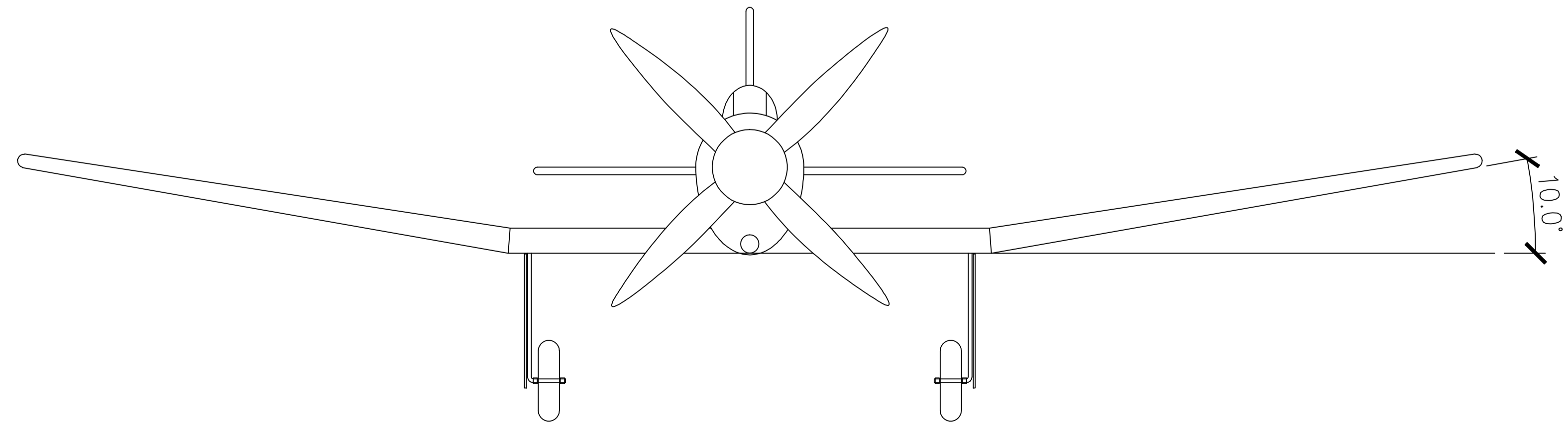

FRONT VIEW

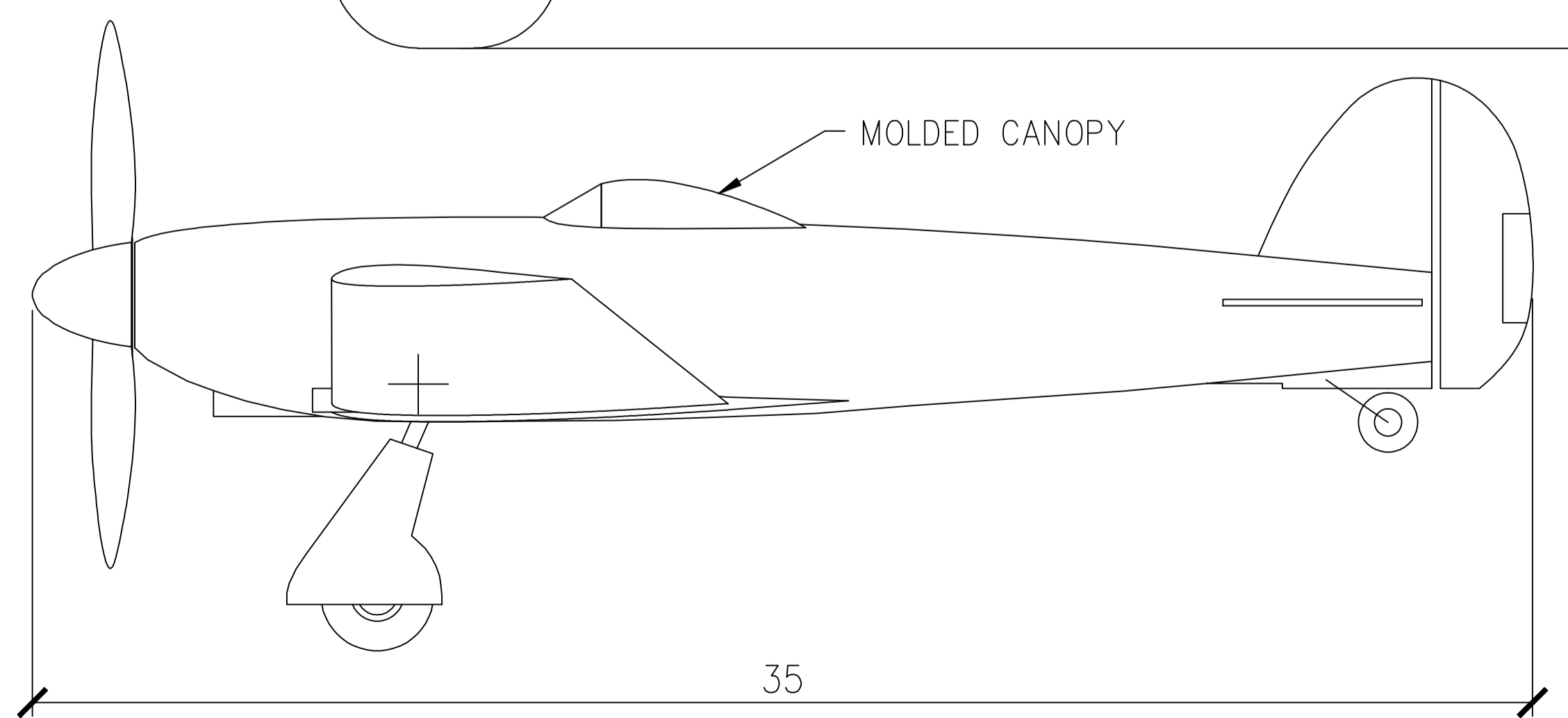

SIDE VIEW

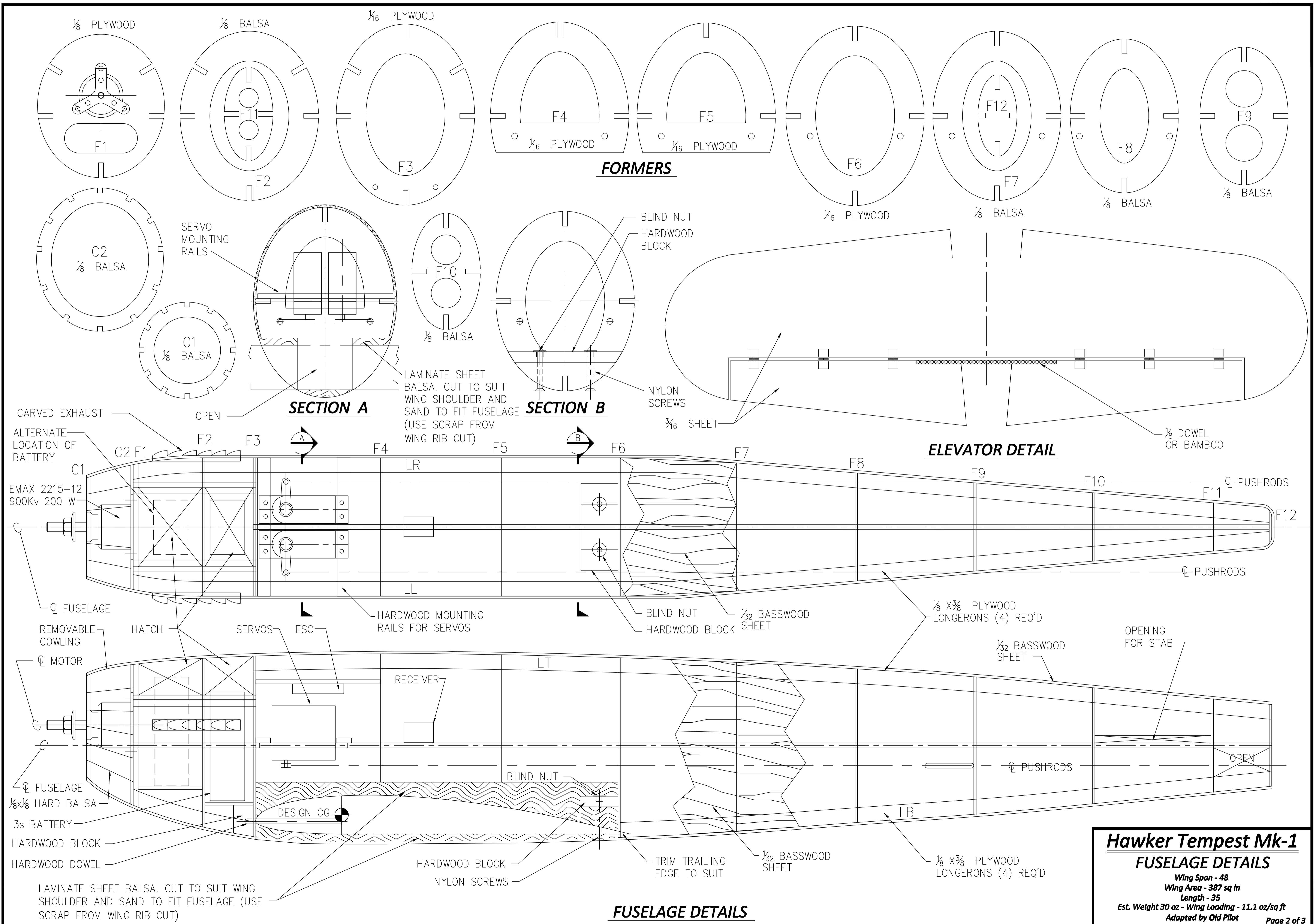

FORMERS

SECTION A

SECTION B

ELEVATOR DETAIL

FUSELAGE DETAILS

Hawker Tempest Mk-1
FUSELAGE DETAILS
 Wing Span - 48
 Wing Area - 387 sq in
 Length - 35
 Est. Weight 30 oz - Wing Loading - 11.1 oz/sq ft
 Adapted by Old Pilot Page 2 of 3

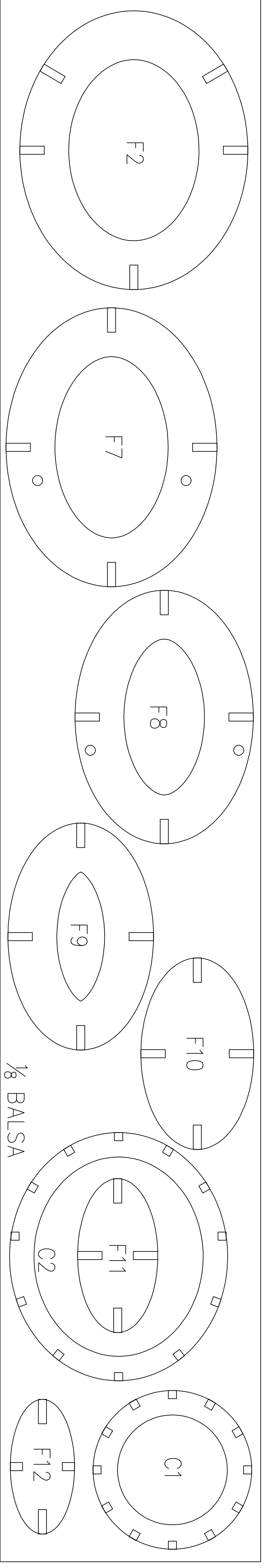
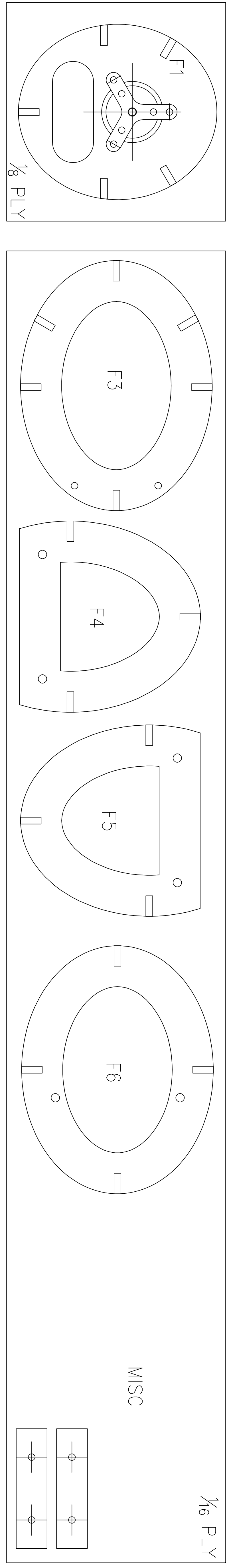
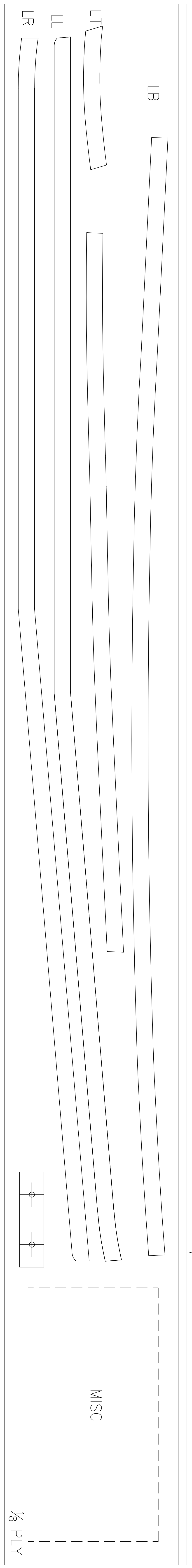
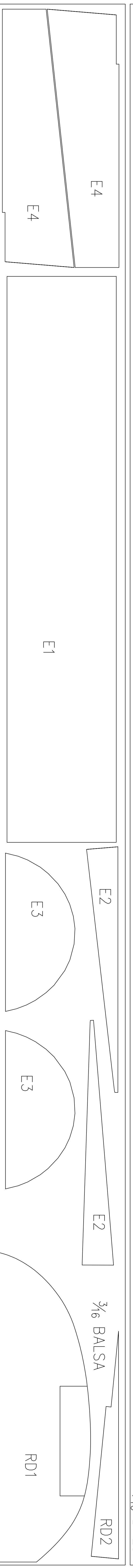
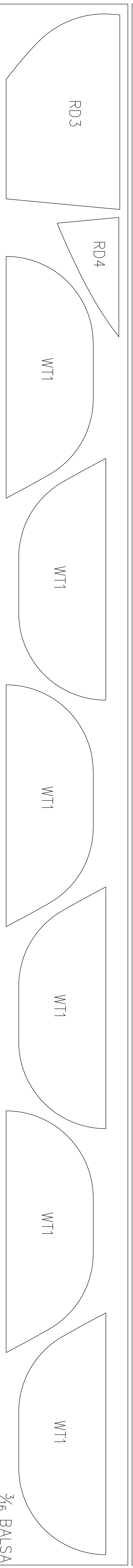
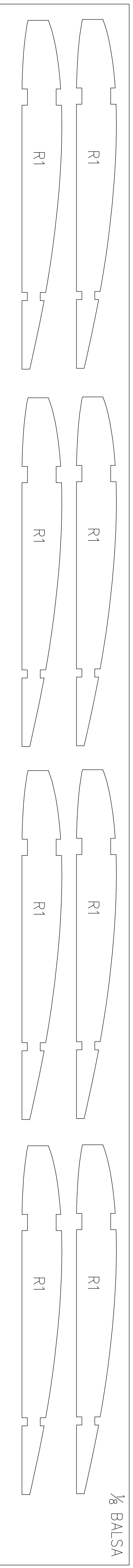
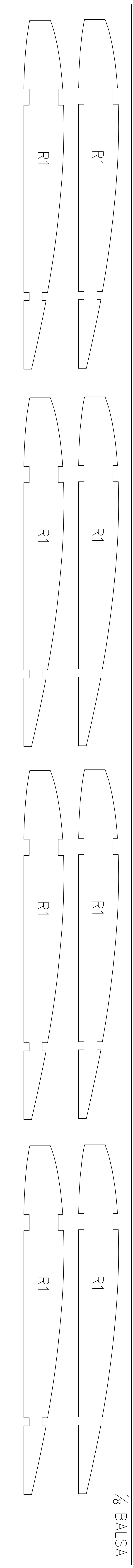
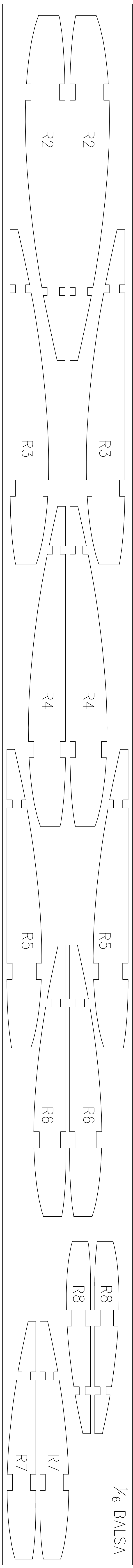

Hawker Tempest Mk-1

PRINTWOOD

Wing Span - 48
 Wing Area - 387 sq in
 Length - 35
 Est. Weight 30 oz - Wing Loading - 11.1 oz/sq ft
 Adapted by Old Pilot
 Page 2 of 3