

Aigoual

Pag. 1 Maqueta escala 1/6, diseño original de B. Perrier en base a planos del Fauvel AV221- Redibujado por Daniel Gomez

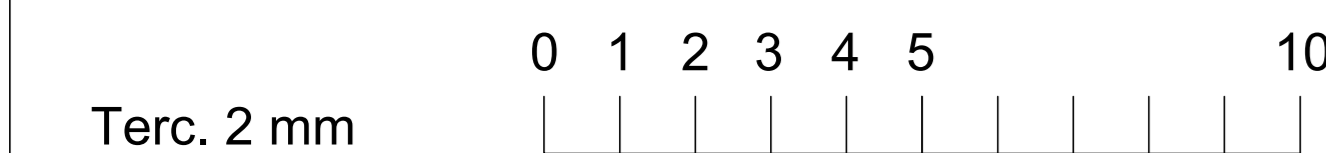

Terc. 2 mm

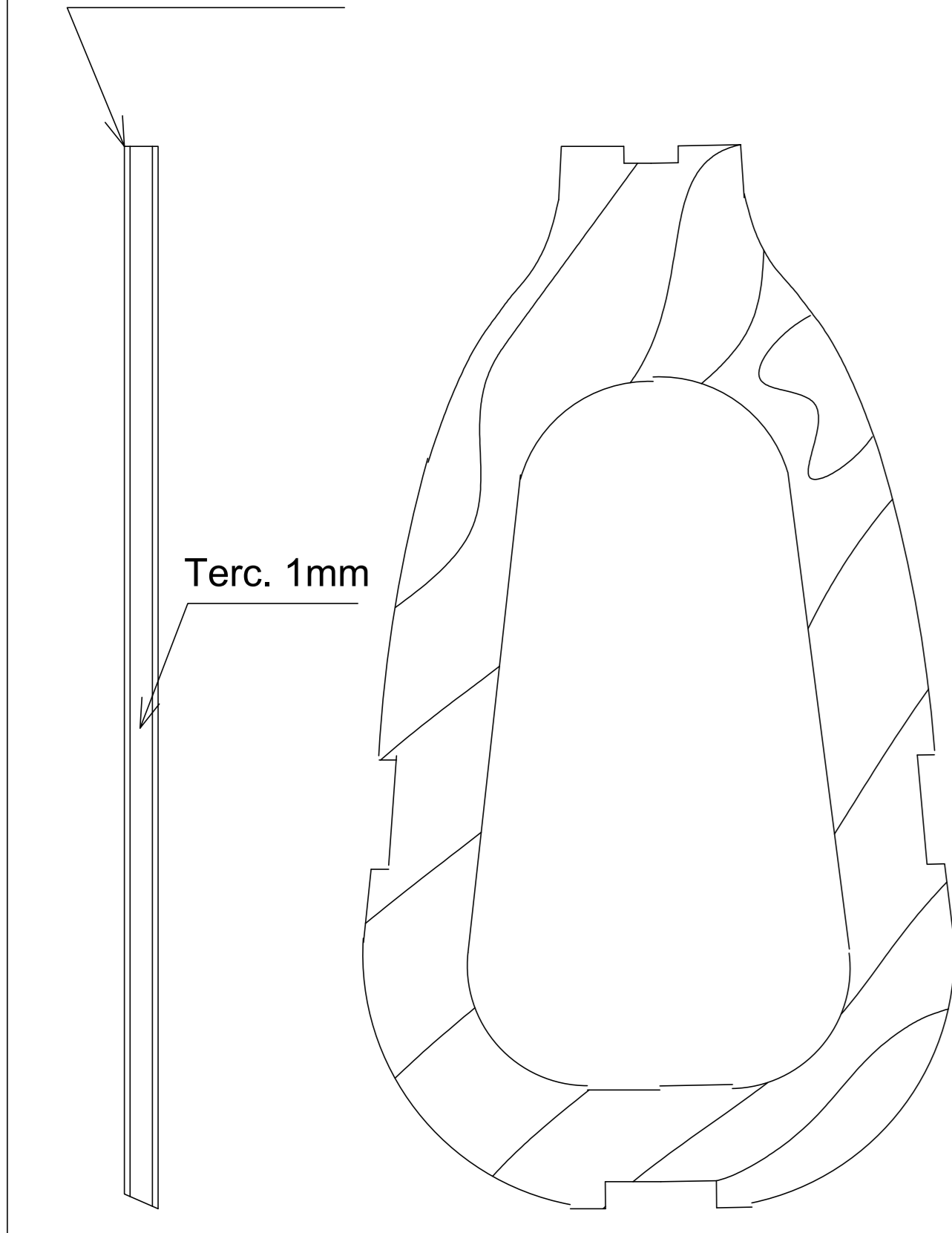

Cuaderna #11

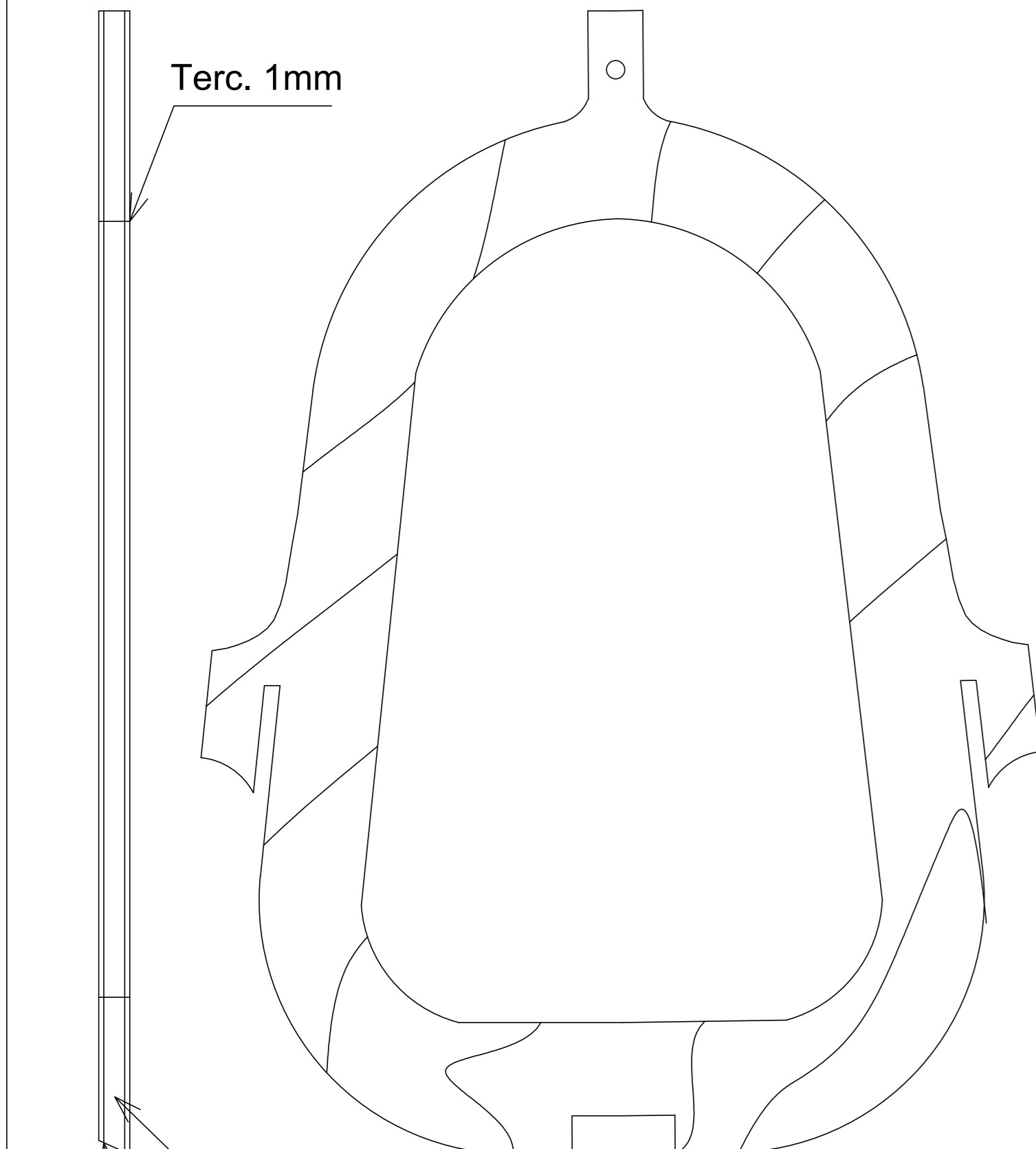

Cuaderna #10

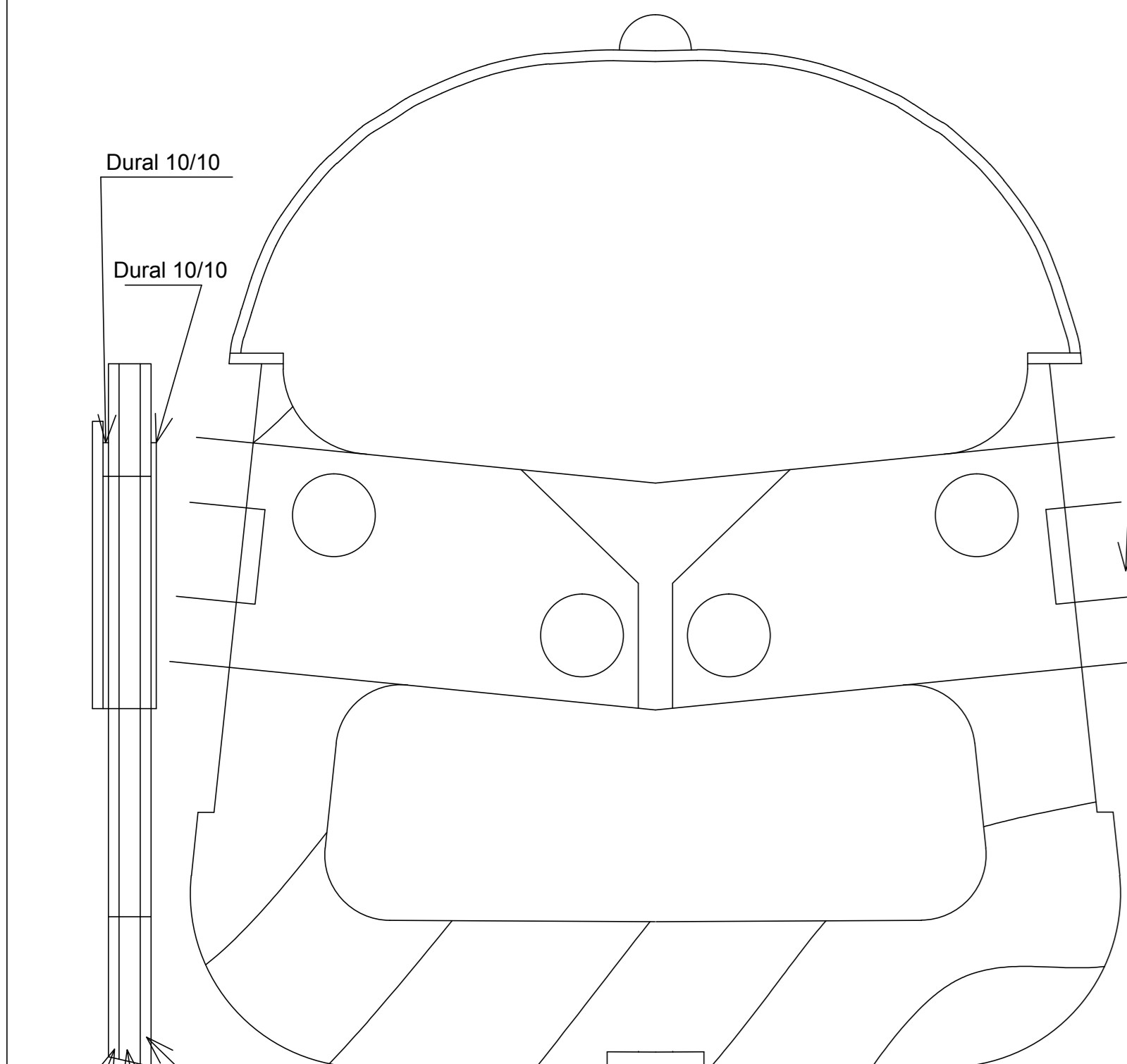

Cuaderna #7

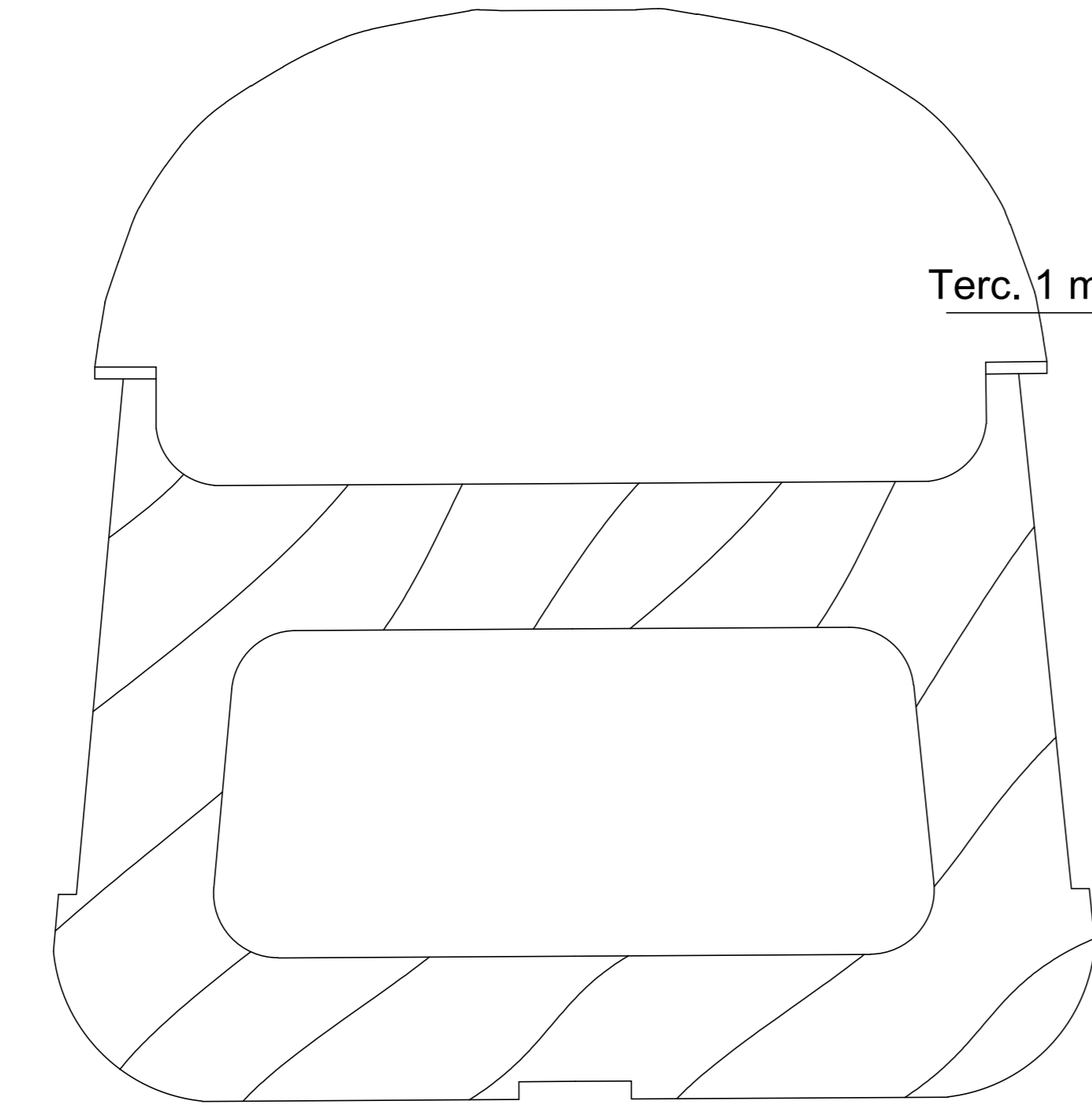

Cuaderna #5

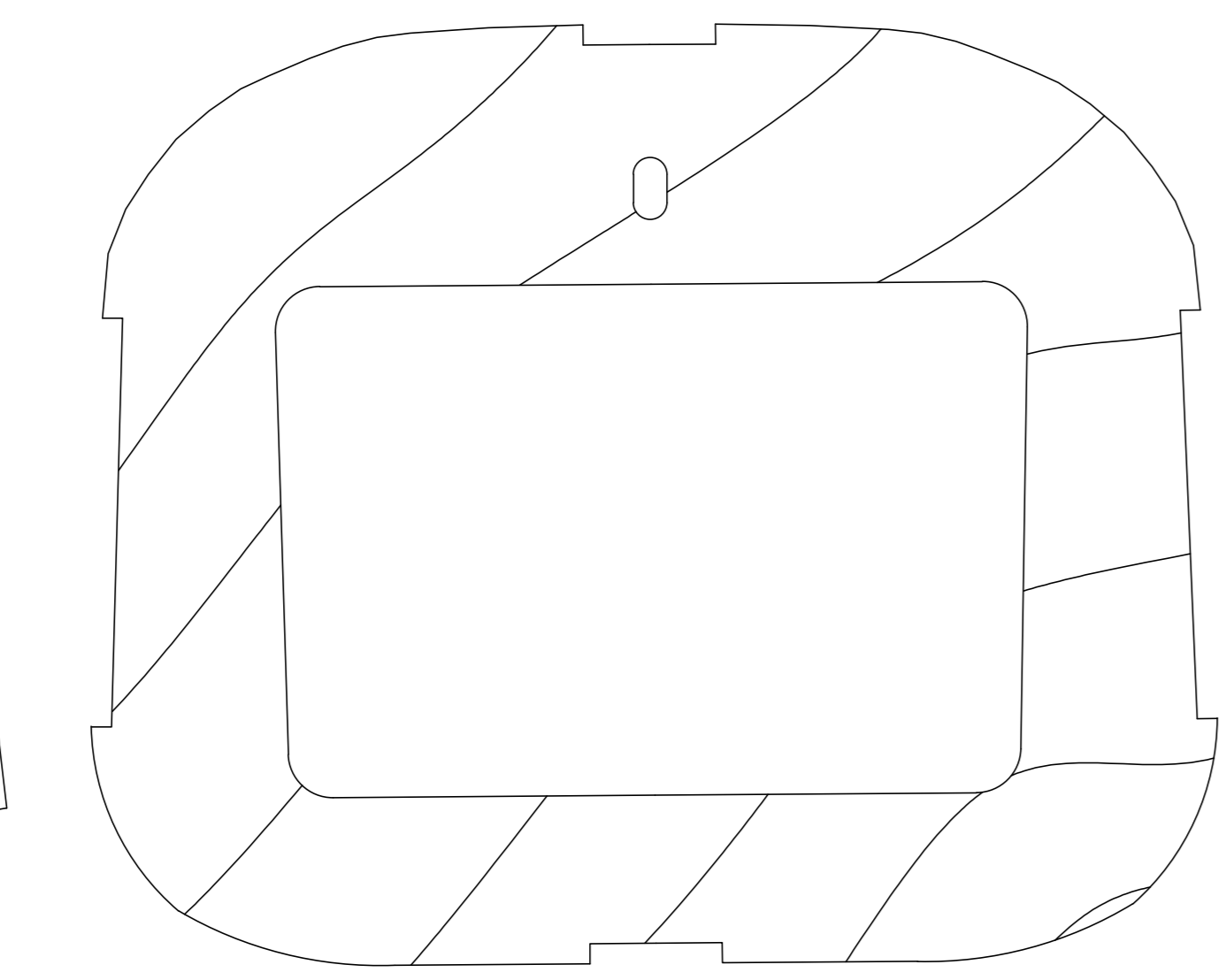

Cuaderna #3

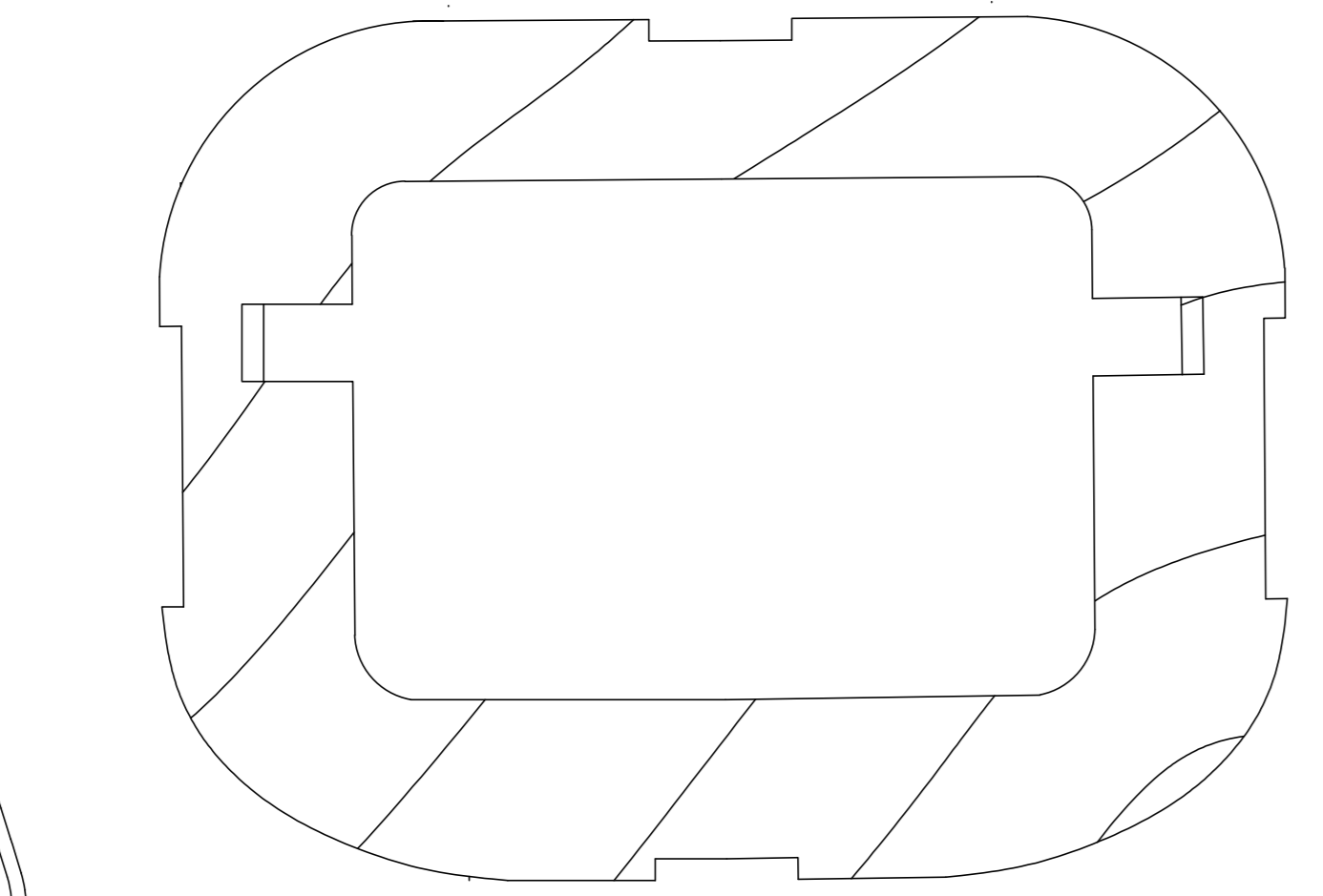

Cuaderna #2

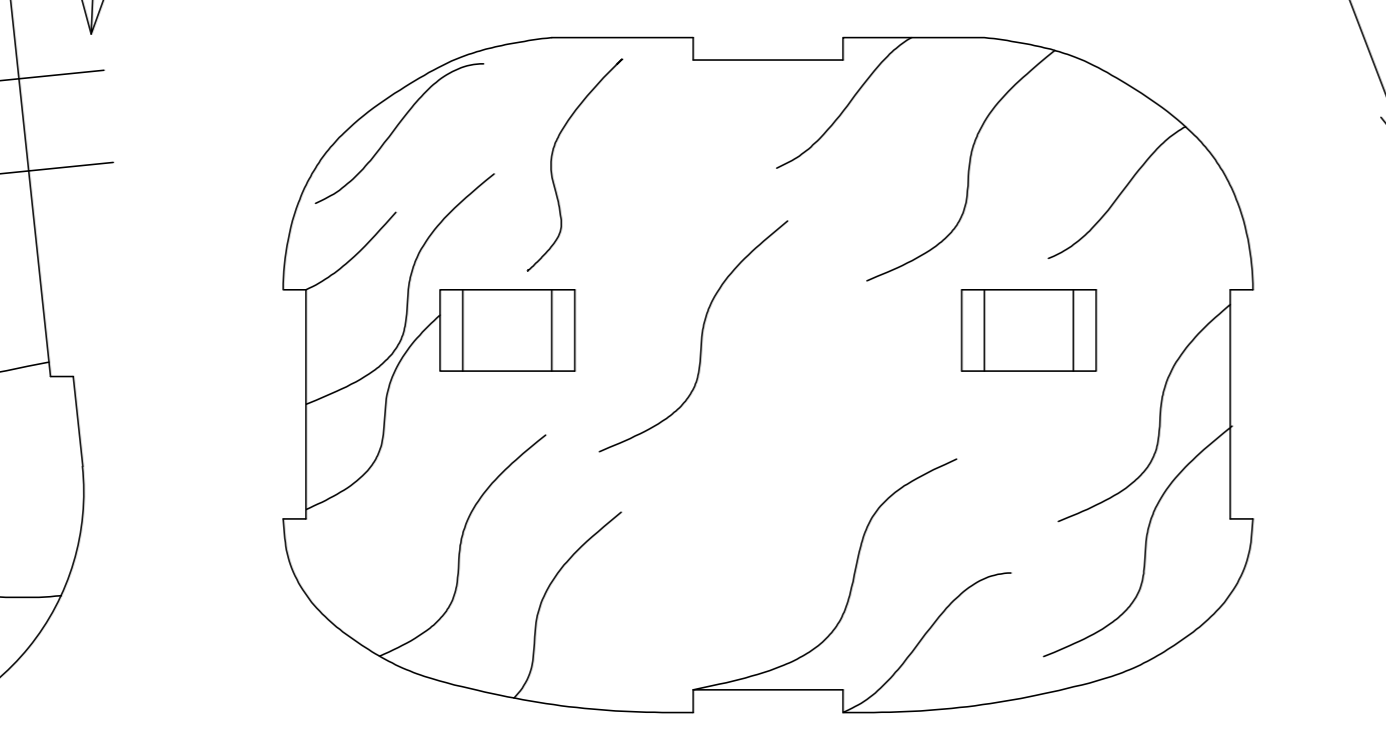

Cuaderna #1

Variante del tren de aterrizaje (Dural 20/10)

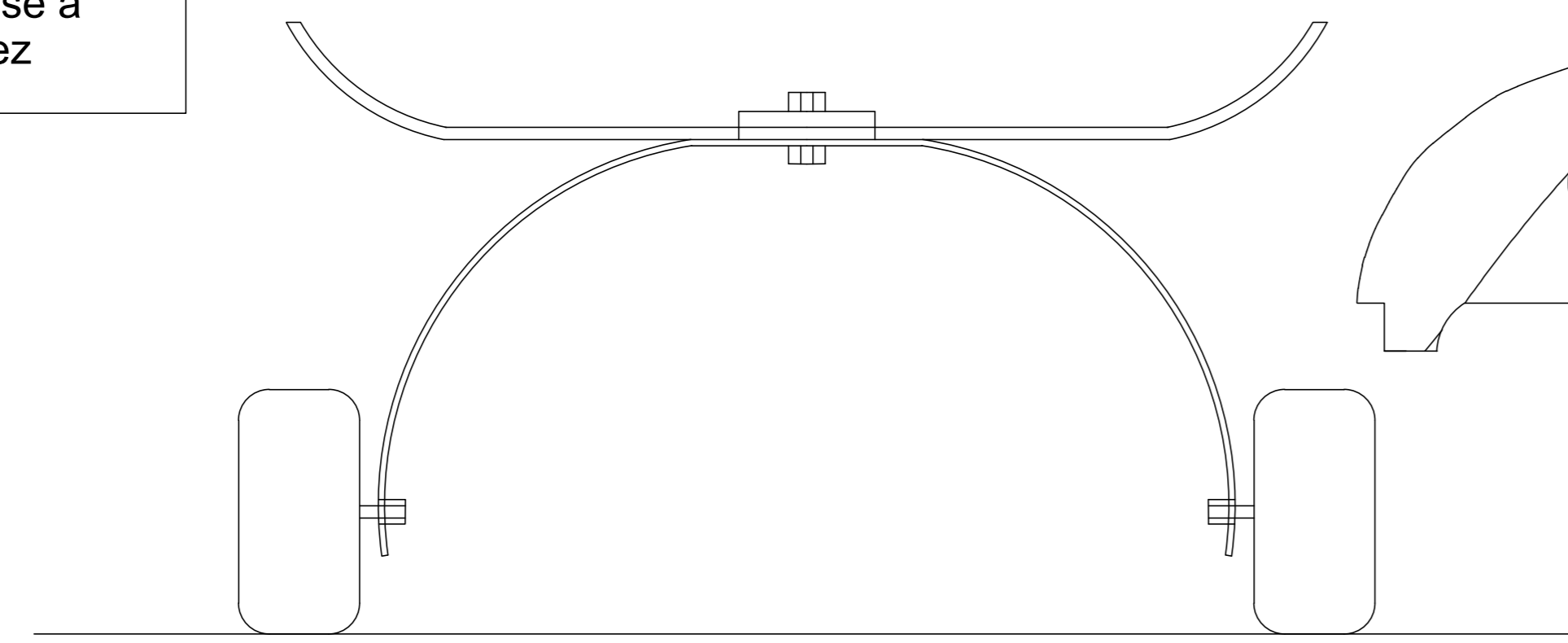

Cuaderna #4

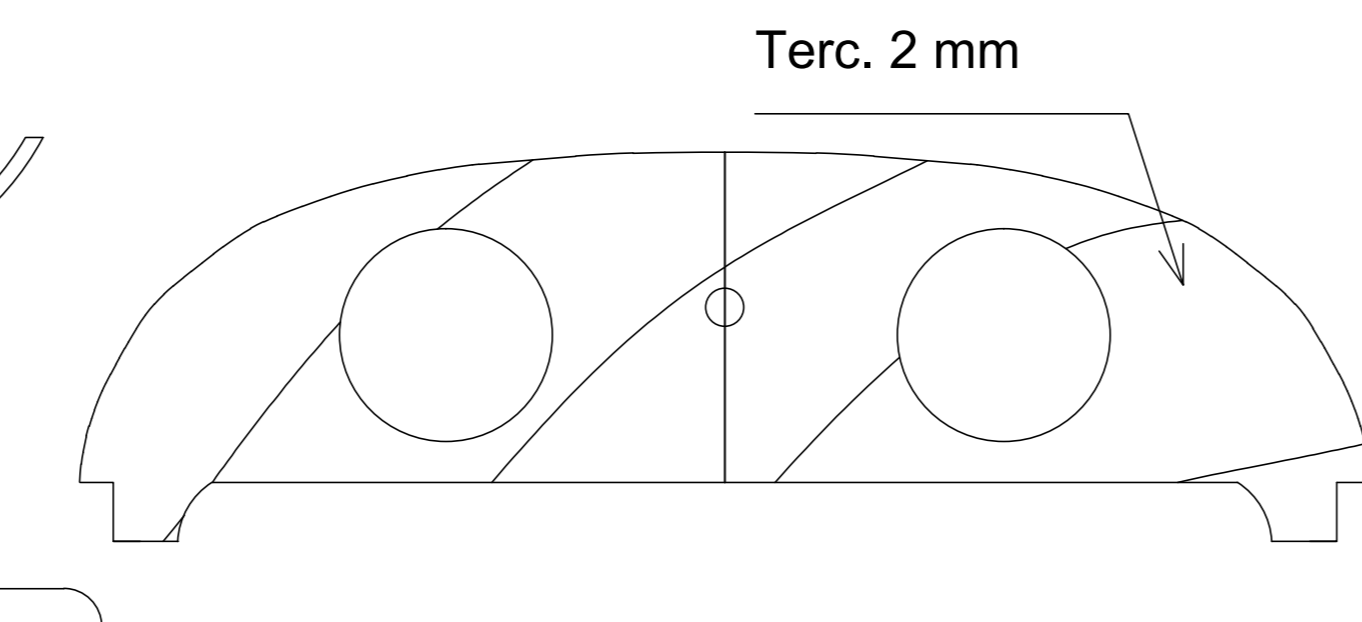

Cuaderna #6

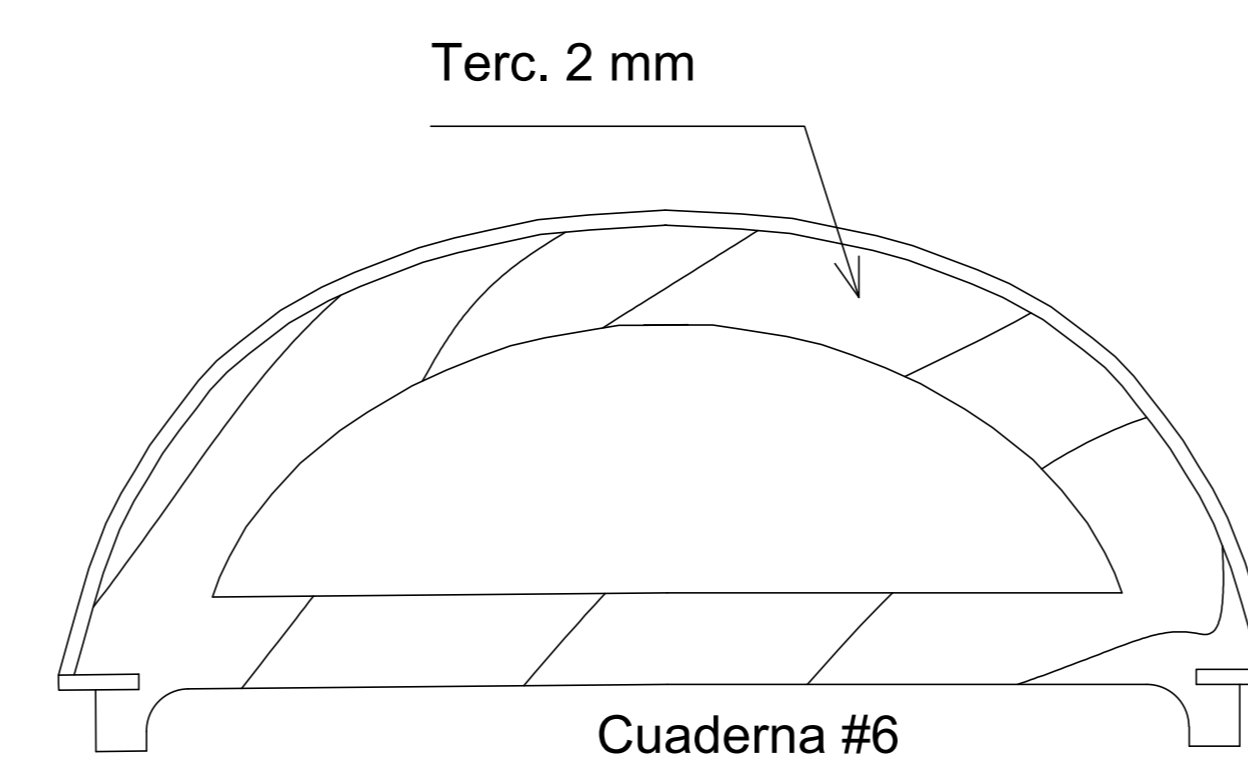

Cuaderna #8

Balsa 2 mm

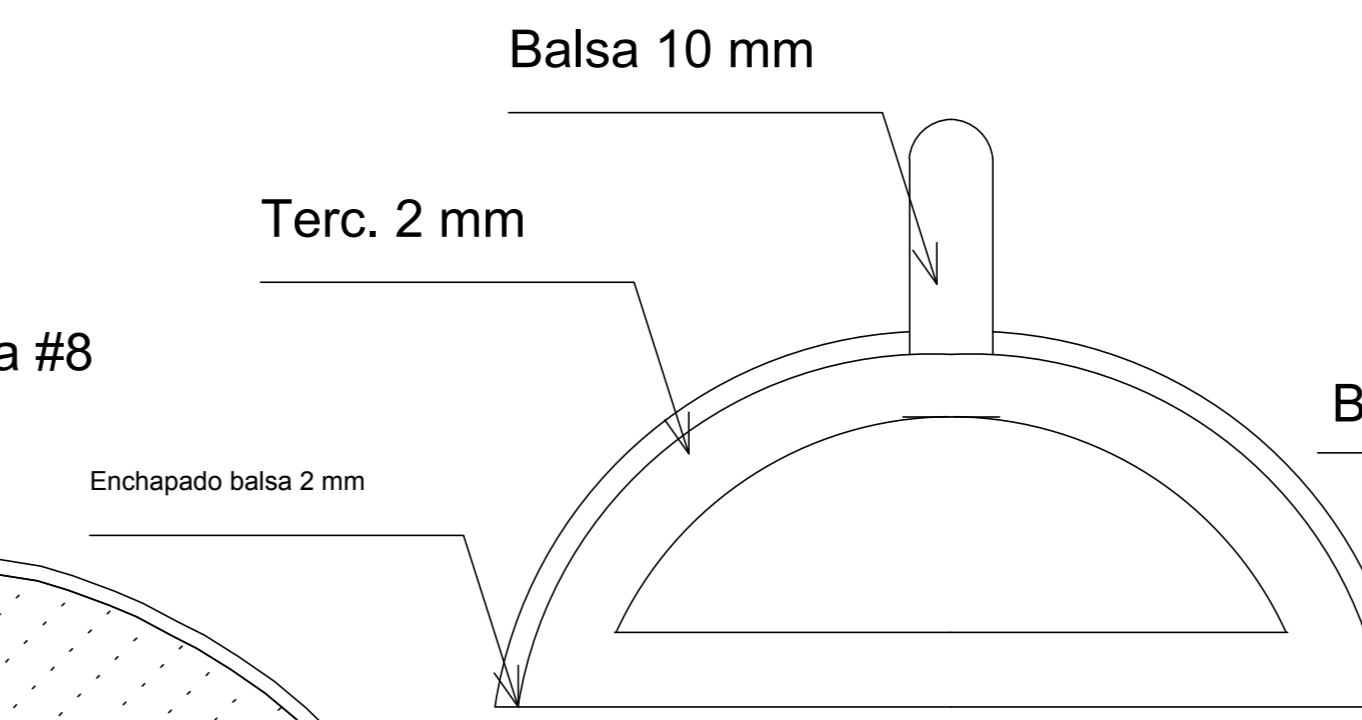

Cuaderna #9

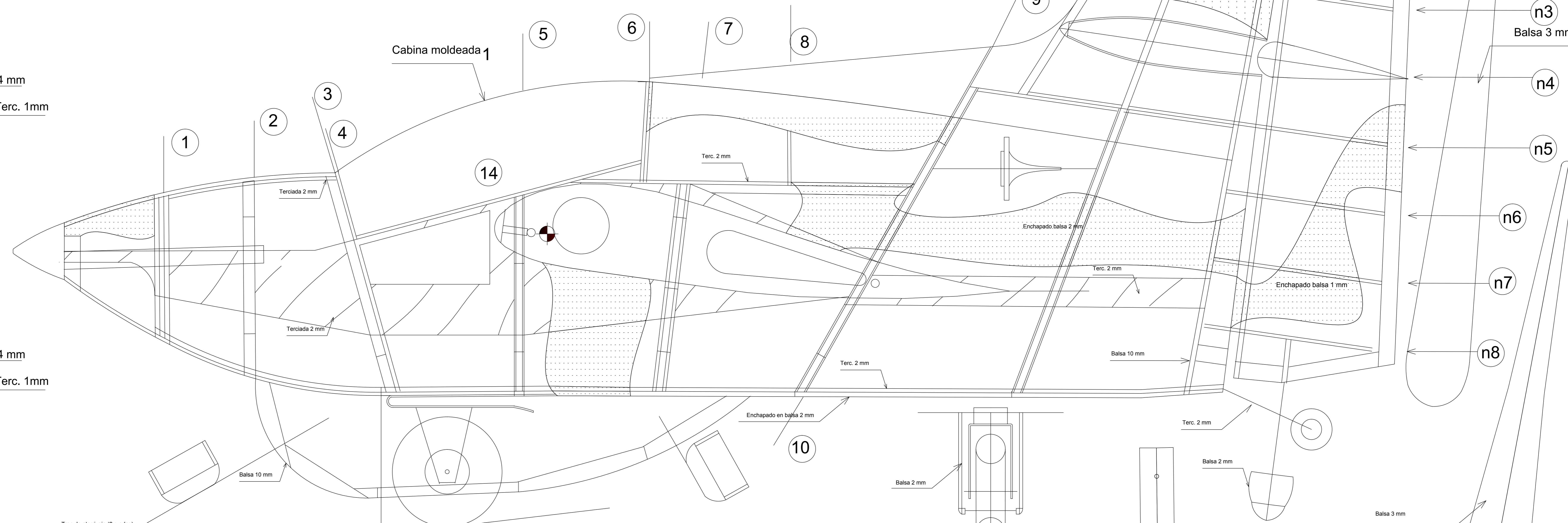

Cabina moldeada 1

15

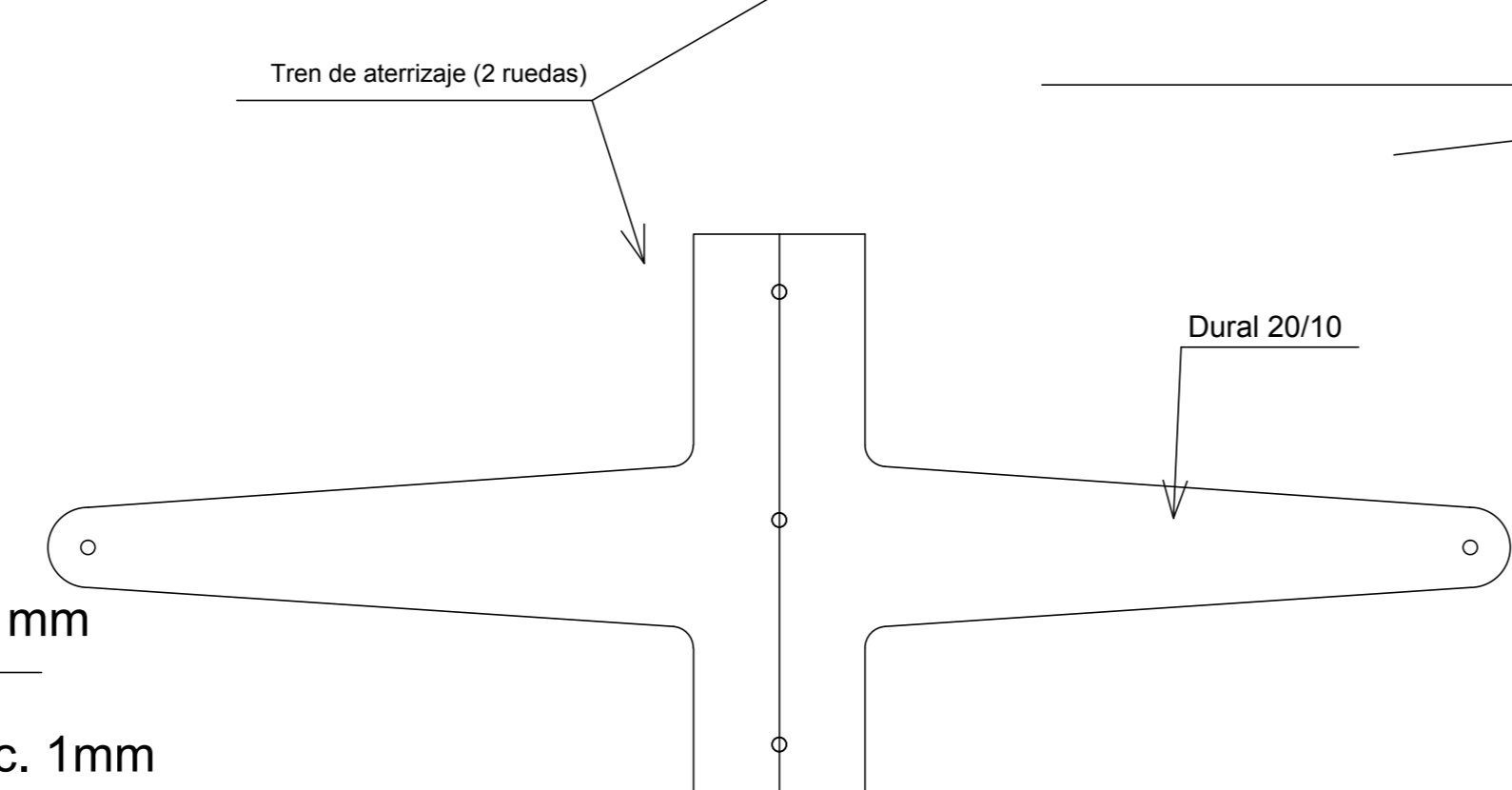

Tren de aterrizaje (2 ruedas)

Dural 20/10

Madera dura 10 mm

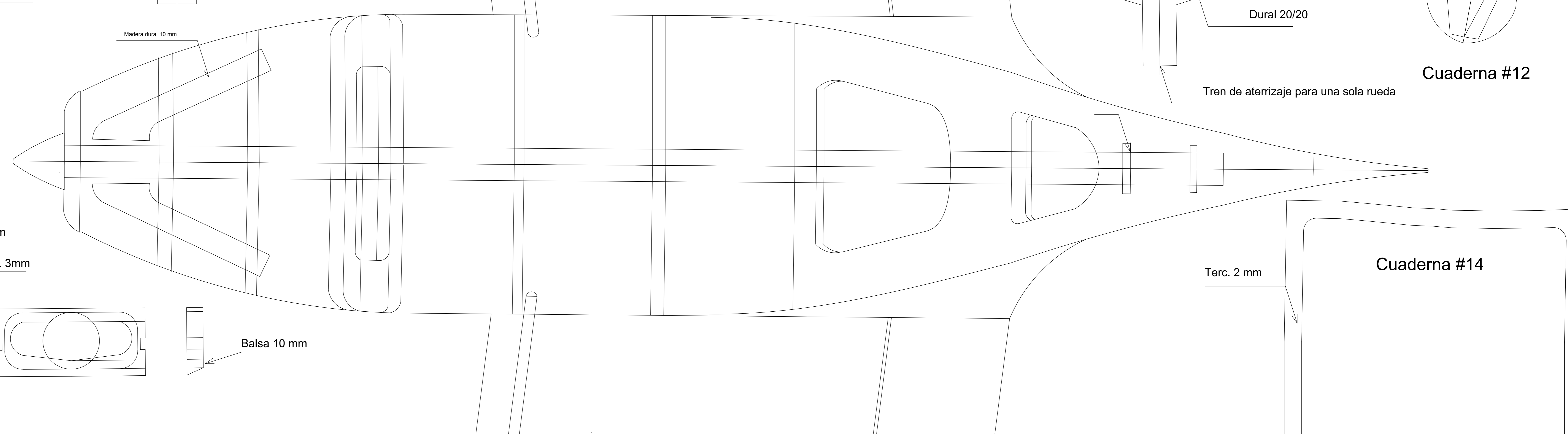

Cuaderna #12

Cuaderna #13

Cuaderna #14

Terc. 2 mm

2.5 mm para tornillo M2

Dural 20/20

Tren de aterrizaje para una sola rueda

Línea de pliegue

2.5 mm para tornillo M2

Dural 20/20

Tren de aterrizaje para una sola rueda

Terc. 2 mm

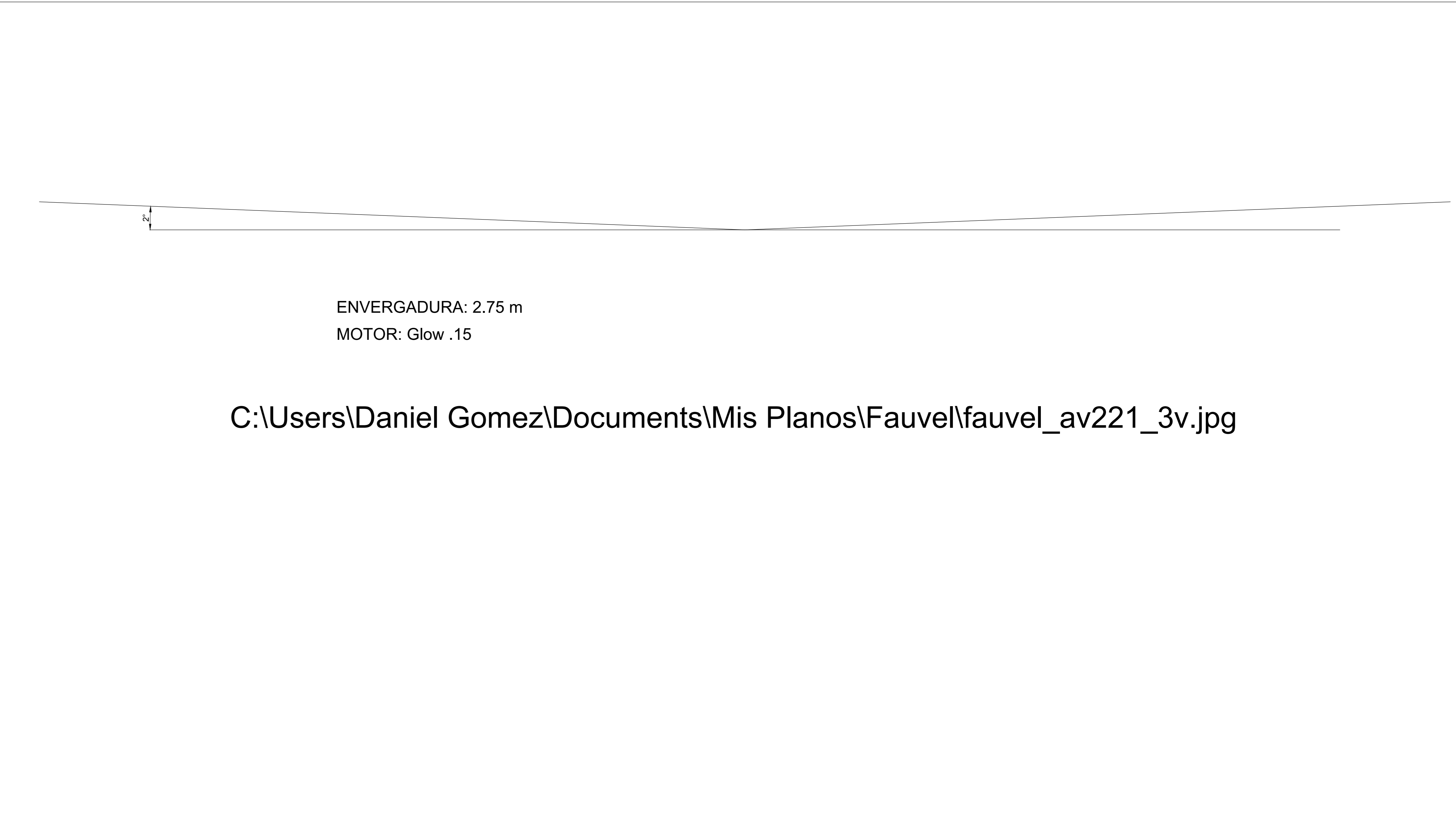


CONSTRUCCION DEL ALA

Aigoual