

Fond arrière fuselage
balsa 15/10

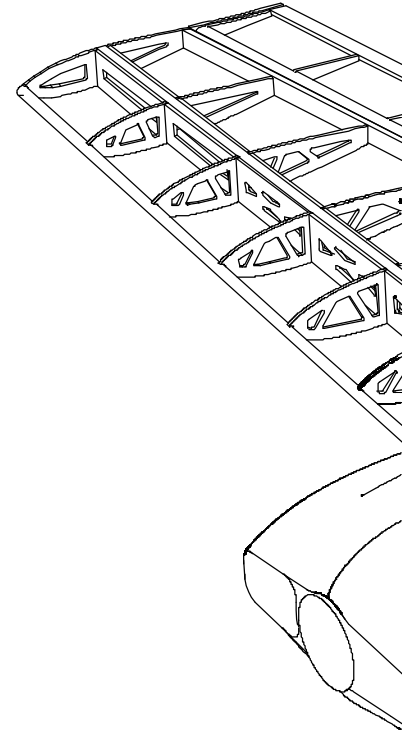

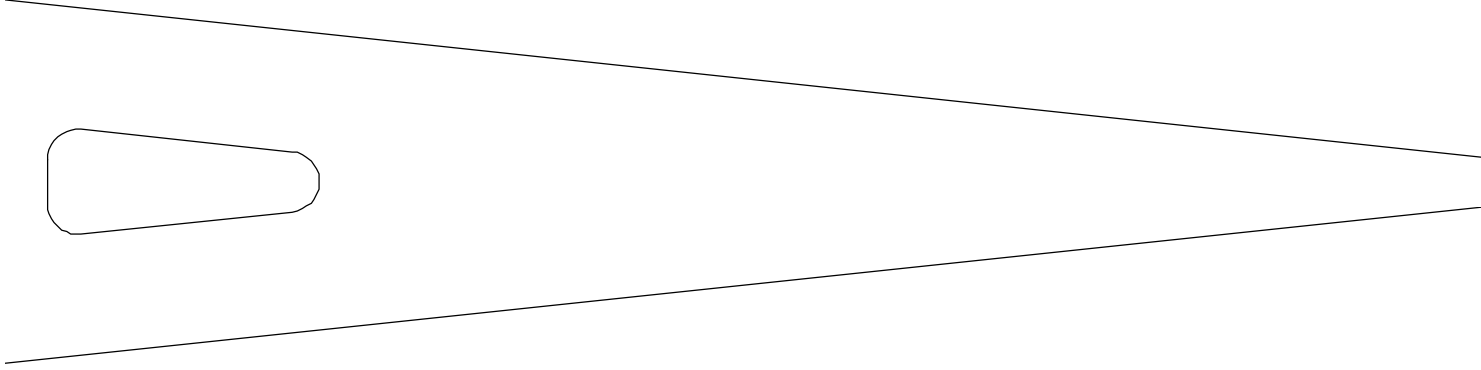

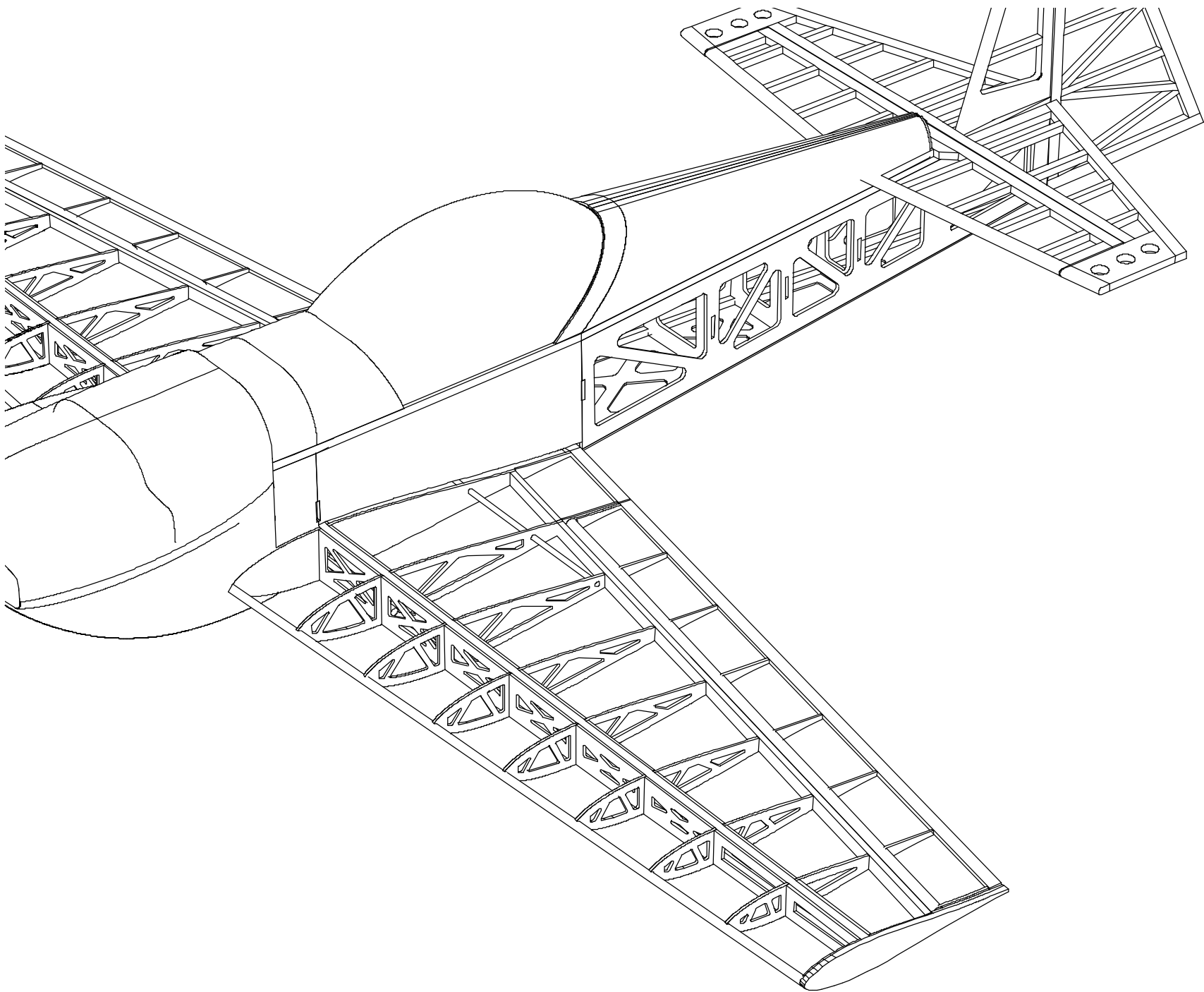
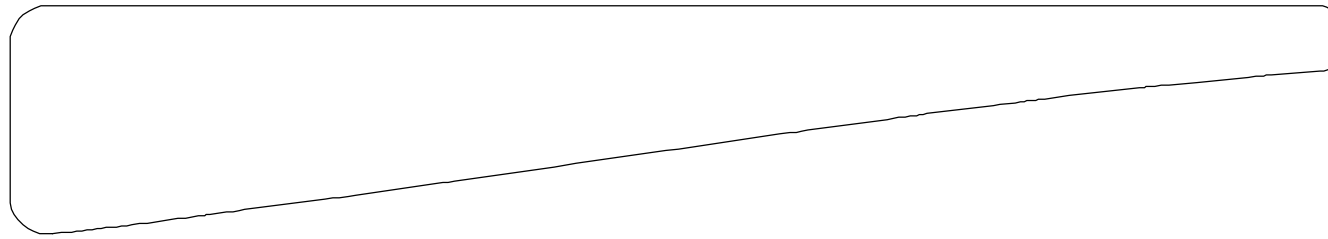

Renfort milieu fuselage
ctp 15/10 ou 20/10

Cap 232 semi maquette

Envergure: 127 cm
Surface ailaire: 30 dm²
Charge ailaire: 70g/dm²
Masse: 1800 - 2000 g
Moteur: thermique Classe 40 ou électrique

Plan fuselage

Echelle: 1/1

Année: 2003

Conception & Dessin: Jean-françois Thier

Contact: <http://www.aerosquare.com>

copyright © 2003 J-F Thier. Toute utilisation commerciale strictement interdite sans accord préalable

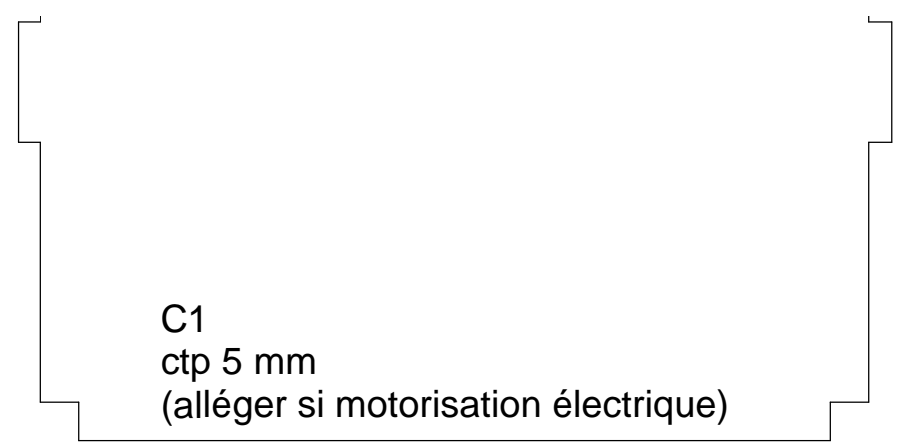

C1
ctp 5 mm
(alléger si motorisation électrique)

The drawing shows a rectangular component with a stepped profile. It has a wider top section and a narrower bottom section. The top corners are rounded. There are small rectangular protrusions on the top and bottom edges, centered horizontally.

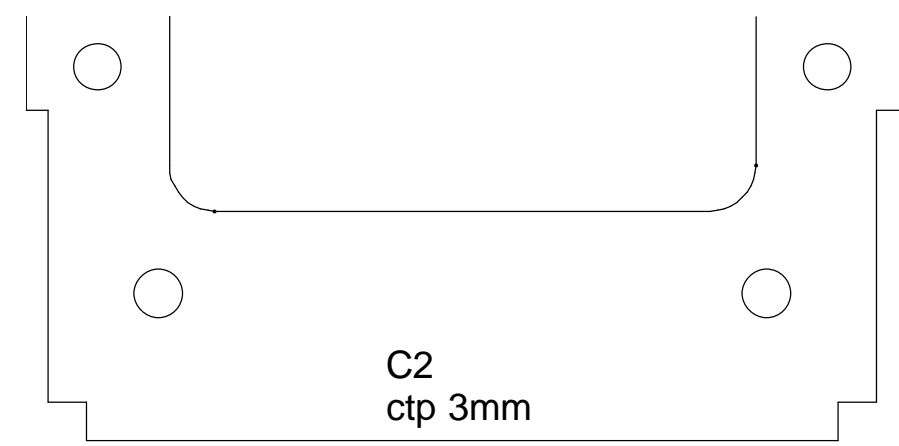

C2
ctp 3mm

The drawing shows a rectangular component with a stepped profile, similar to C1 but with a different width. It features four circular holes, two on the top edge and two on the bottom edge, arranged in a 2x2 grid. The top corners are rounded.

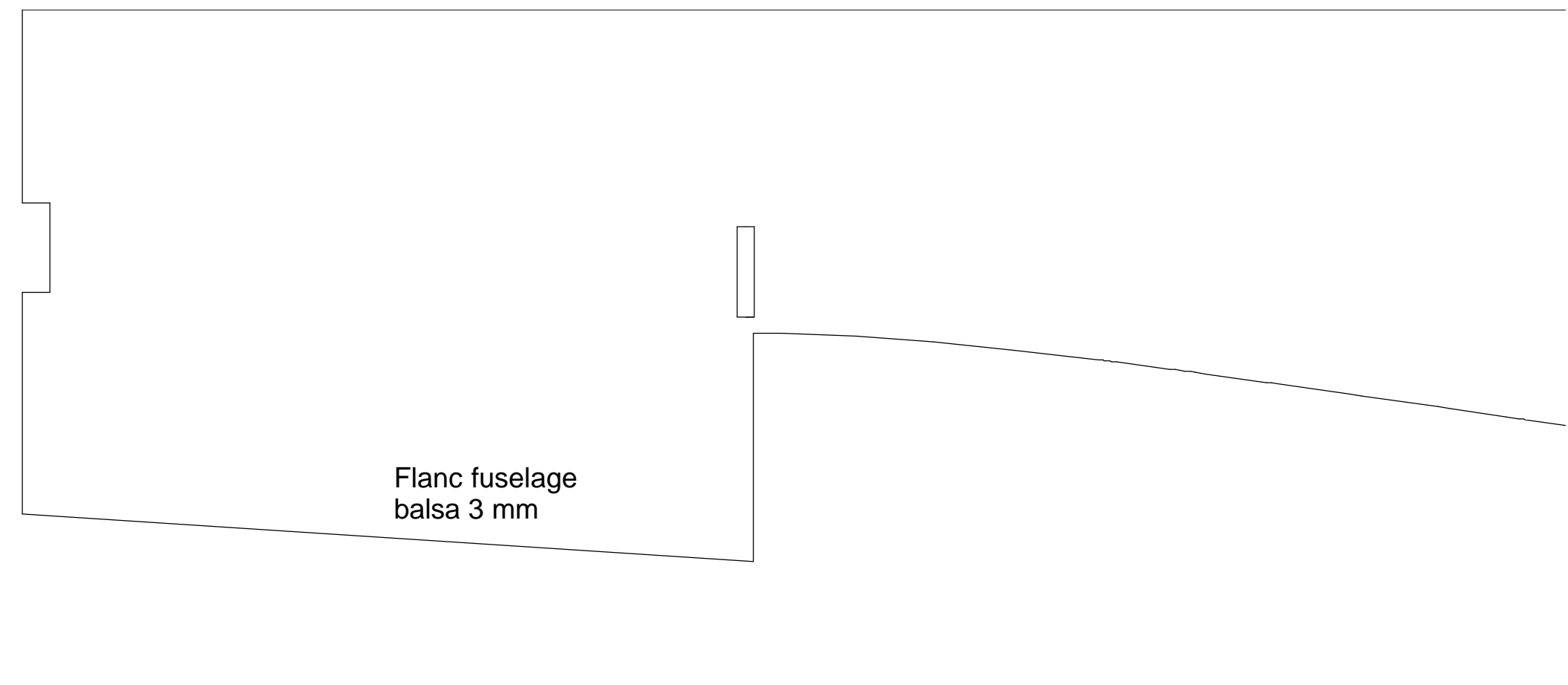

Flanc fuselage
balsa 3 mm

The drawing shows a large, trapezoidal component representing the fuselage side. The top edge is horizontal, and the bottom edge is slightly angled downwards from left to right. On the left side, there are two rectangular protrusions of different heights. On the right side, there is a vertical rectangular slot. A thin vertical line is drawn to the right of the main component, extending from the top edge to the bottom edge.

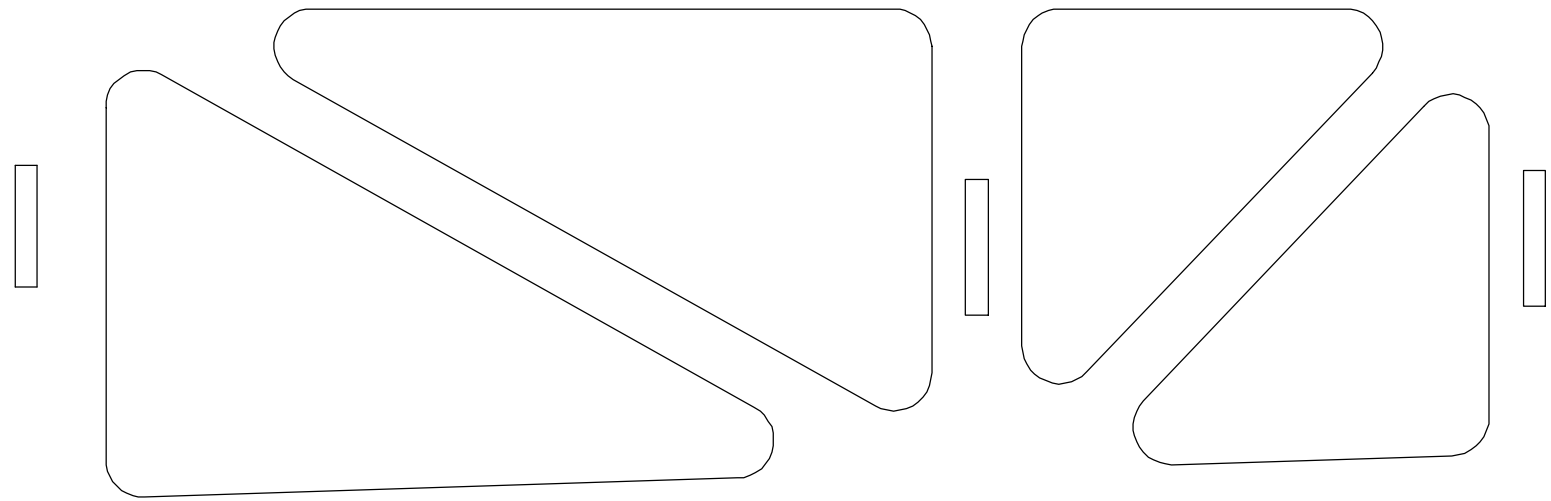
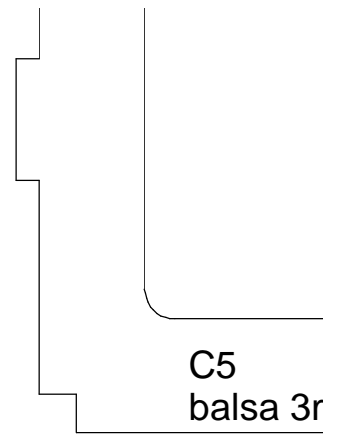
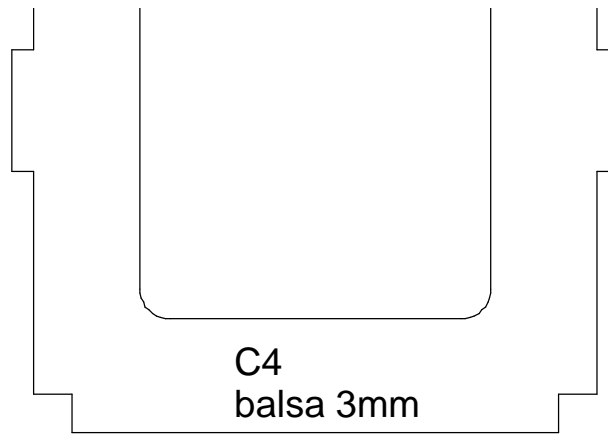

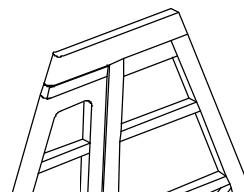
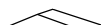
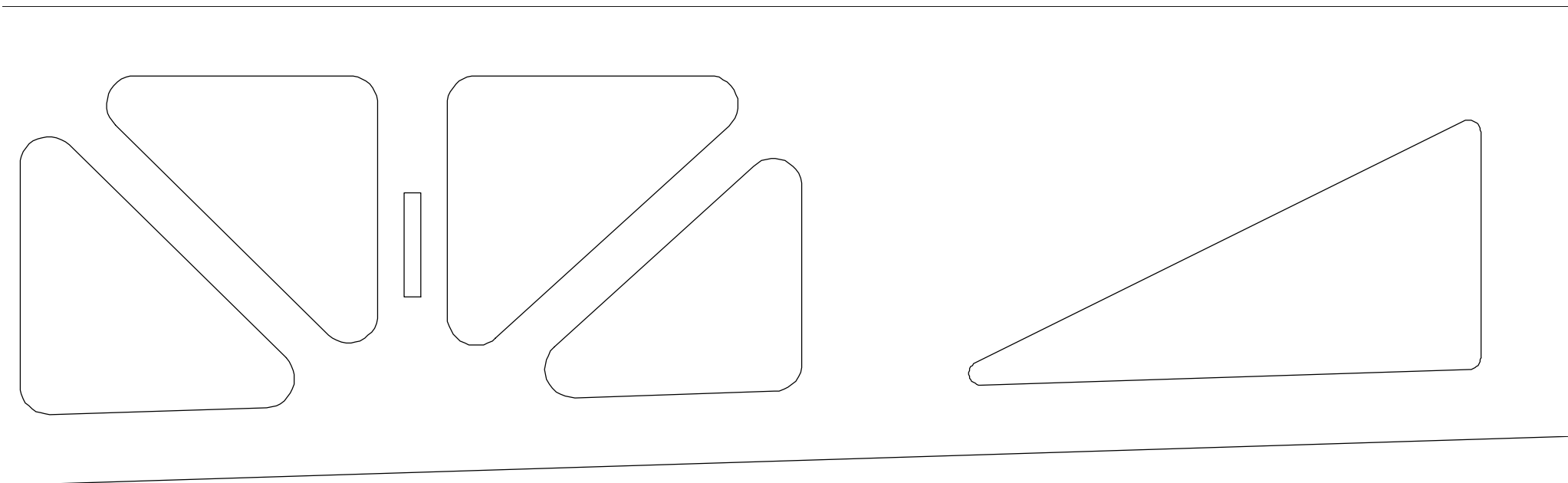
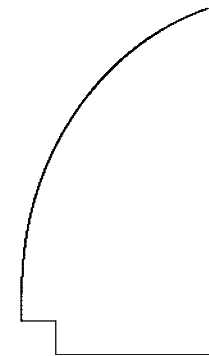
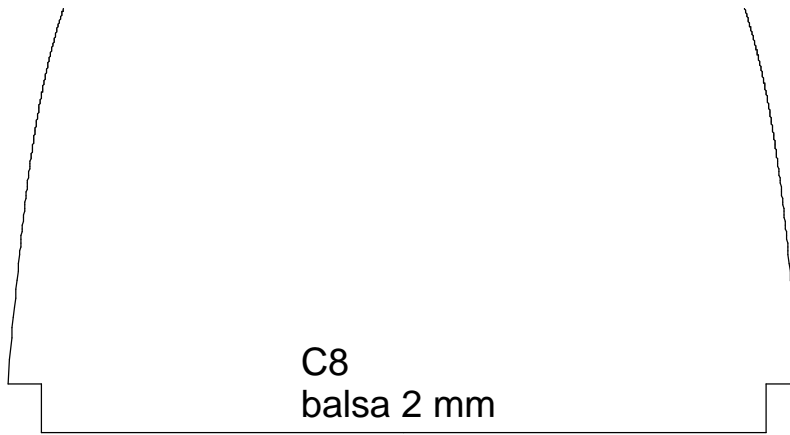
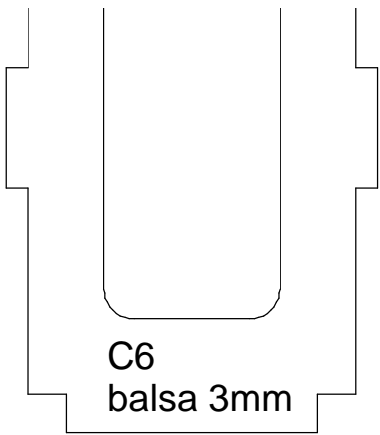
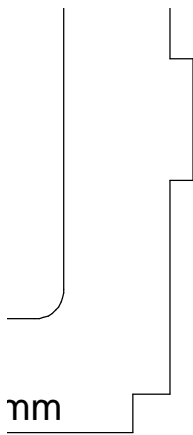

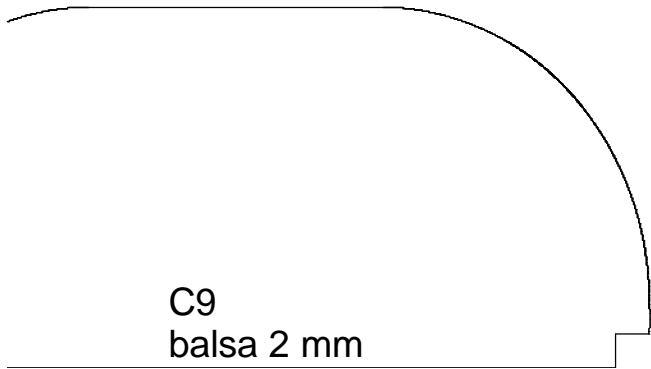

C9
balsa 2 mm

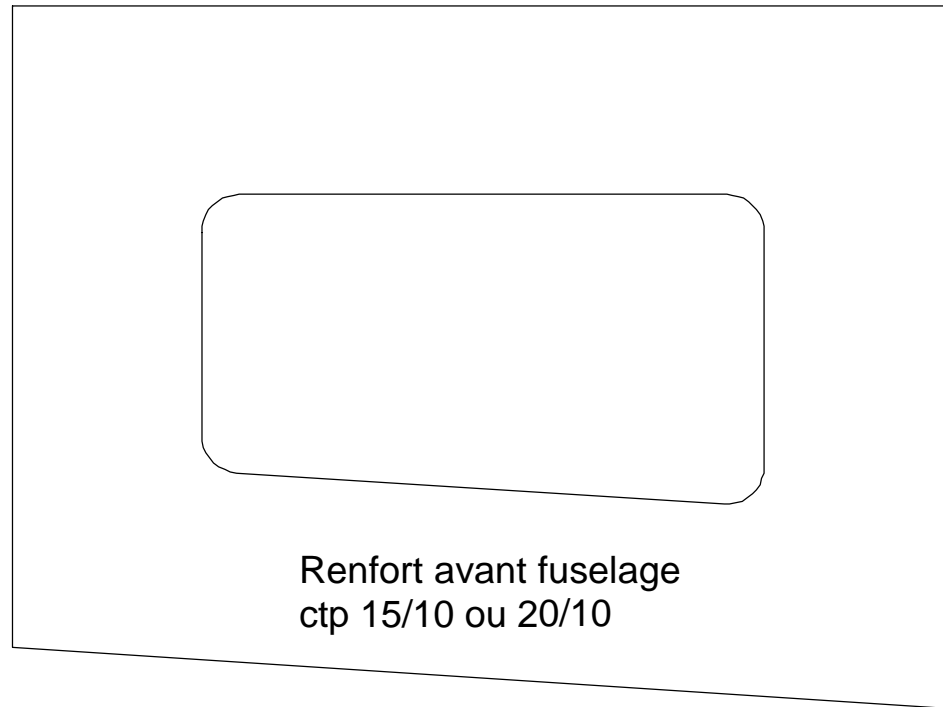

Renfort avant fuselage
ctp 15/10 ou 20/10

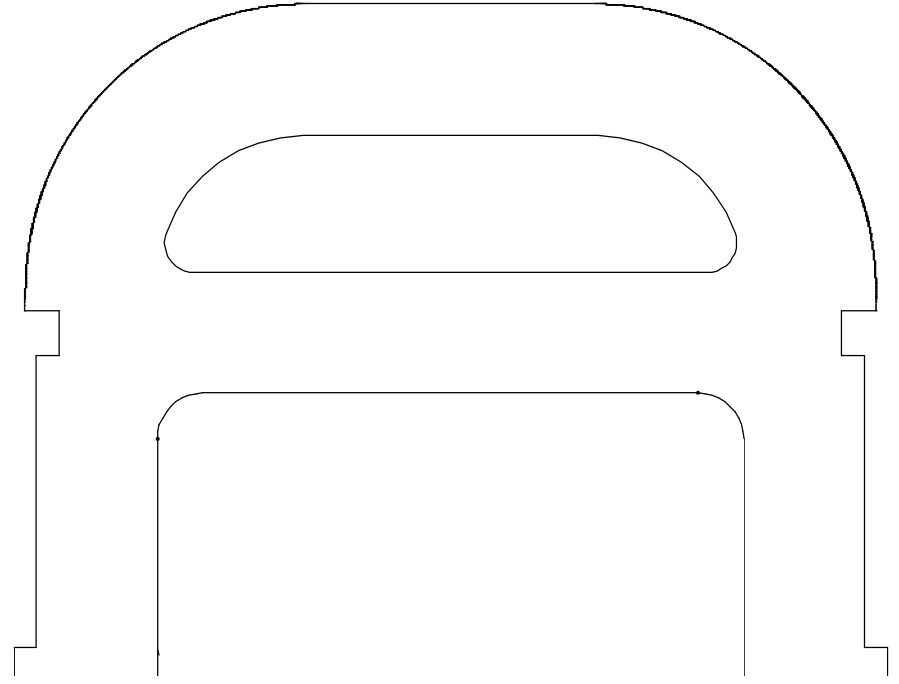
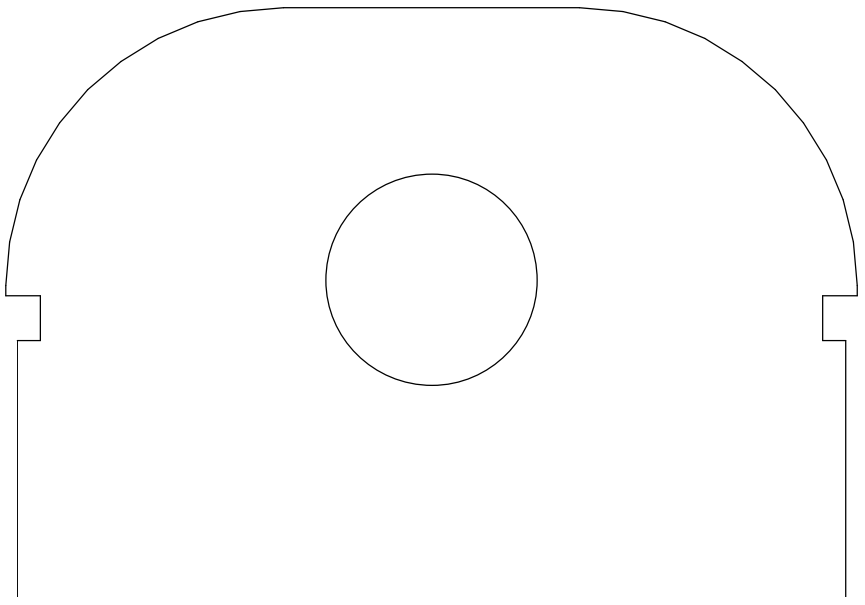
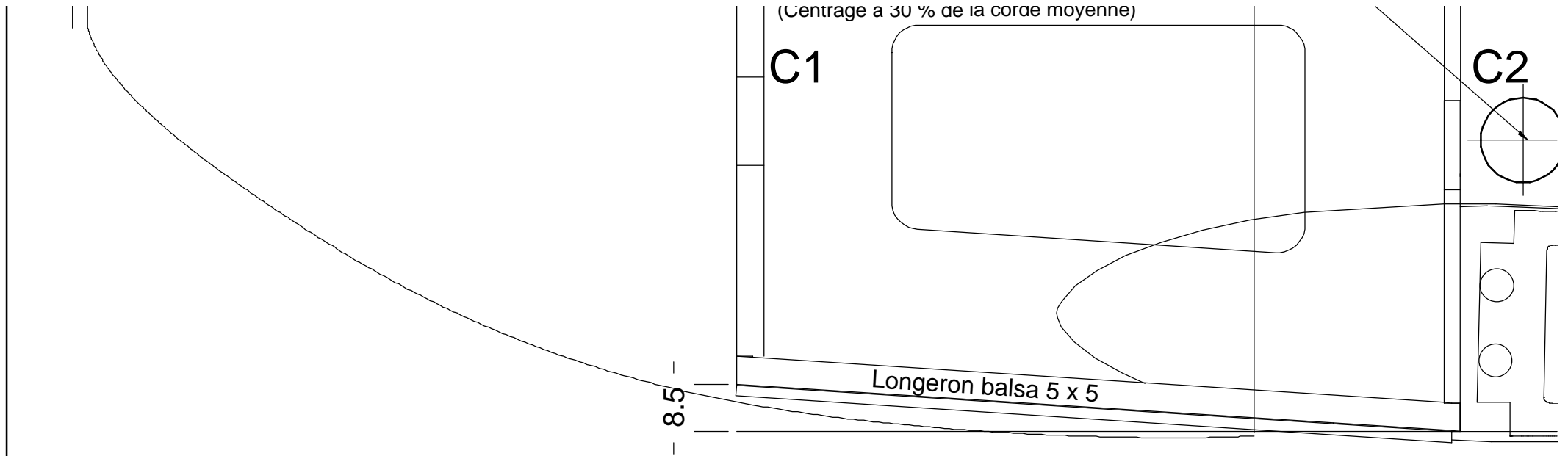

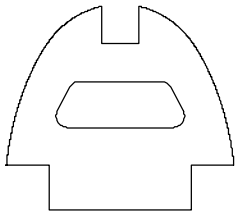
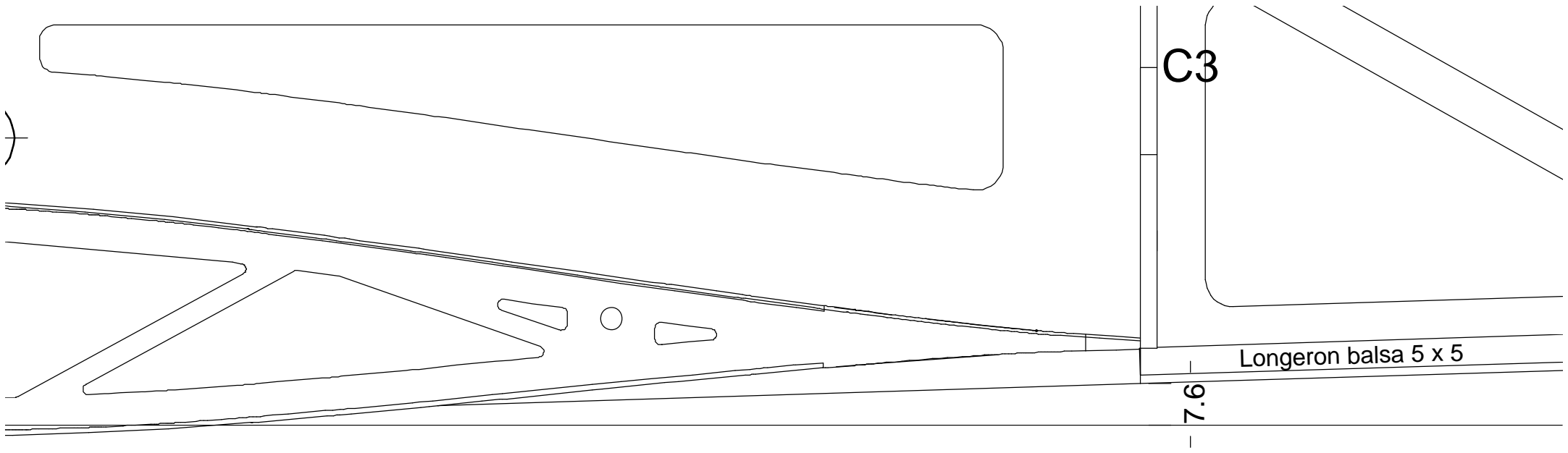

C7
balsa 3mm

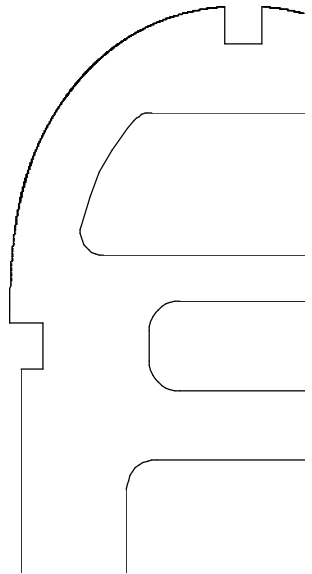
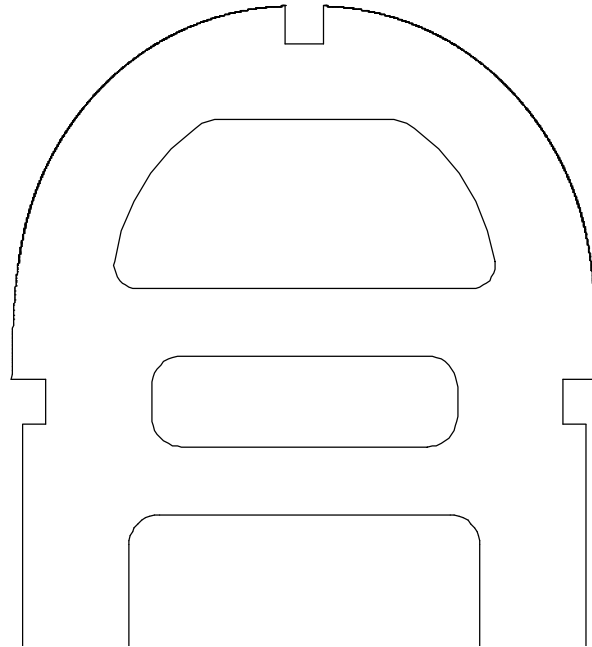
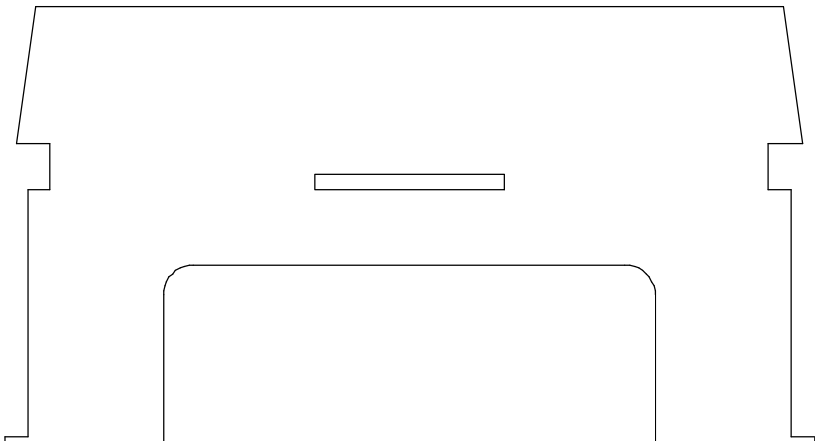

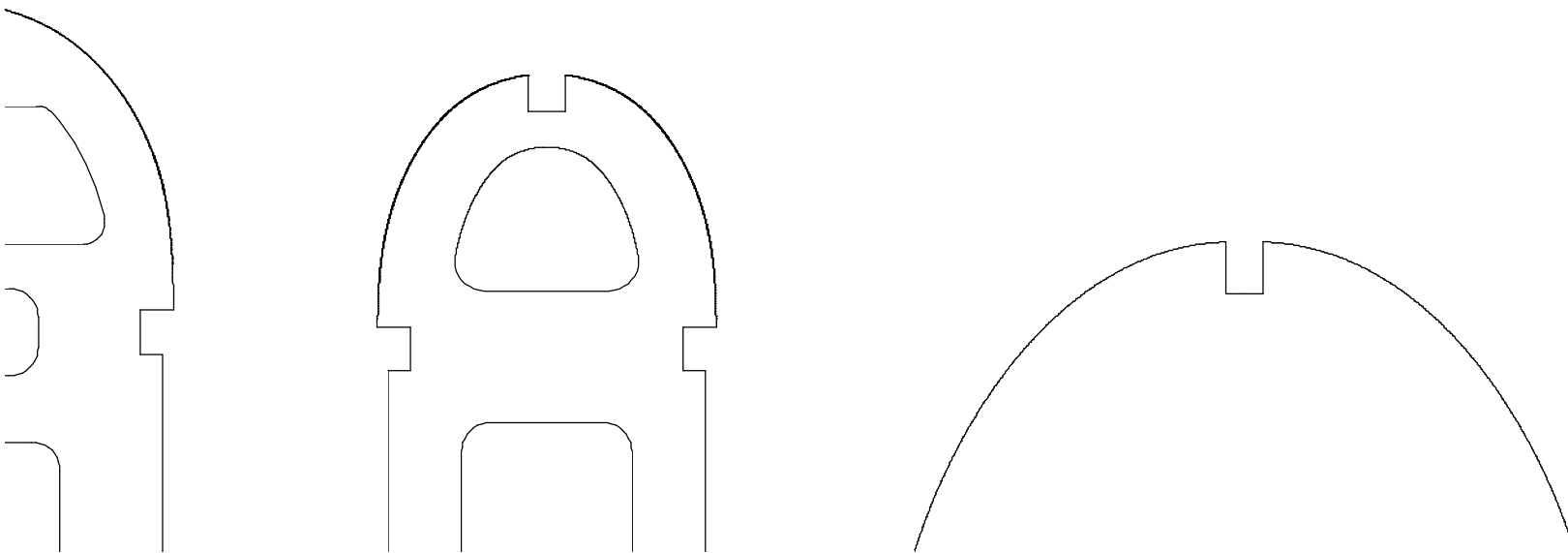
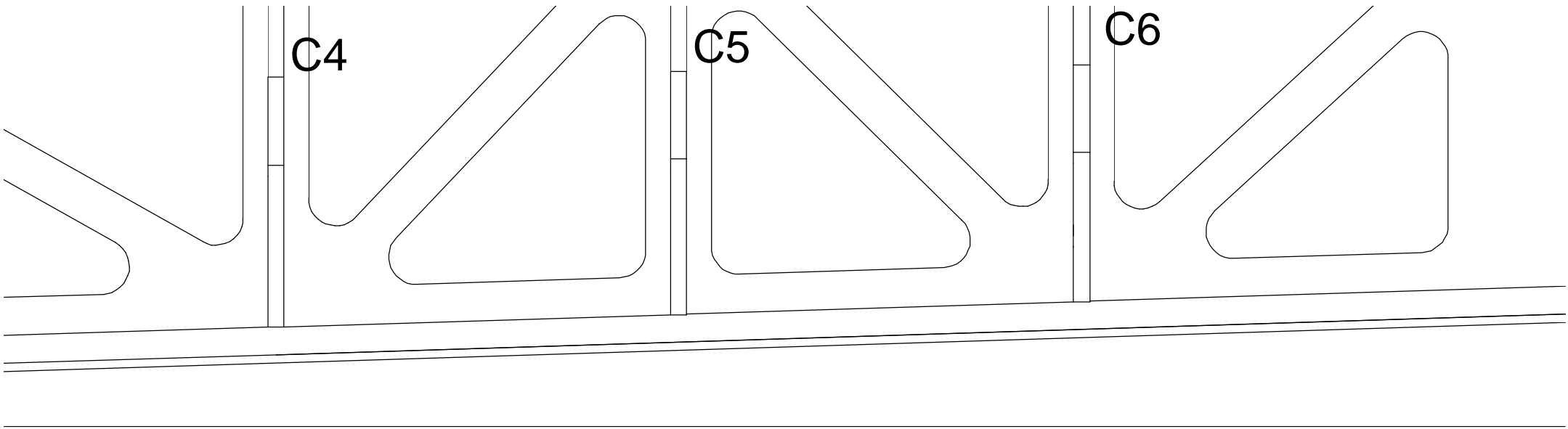

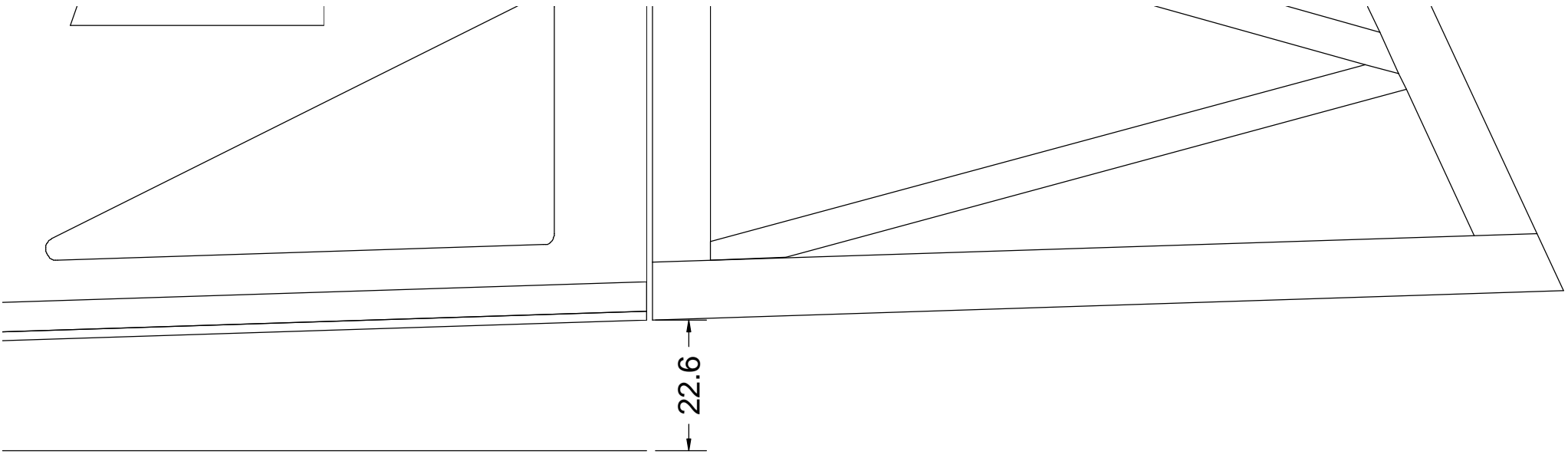

22.6

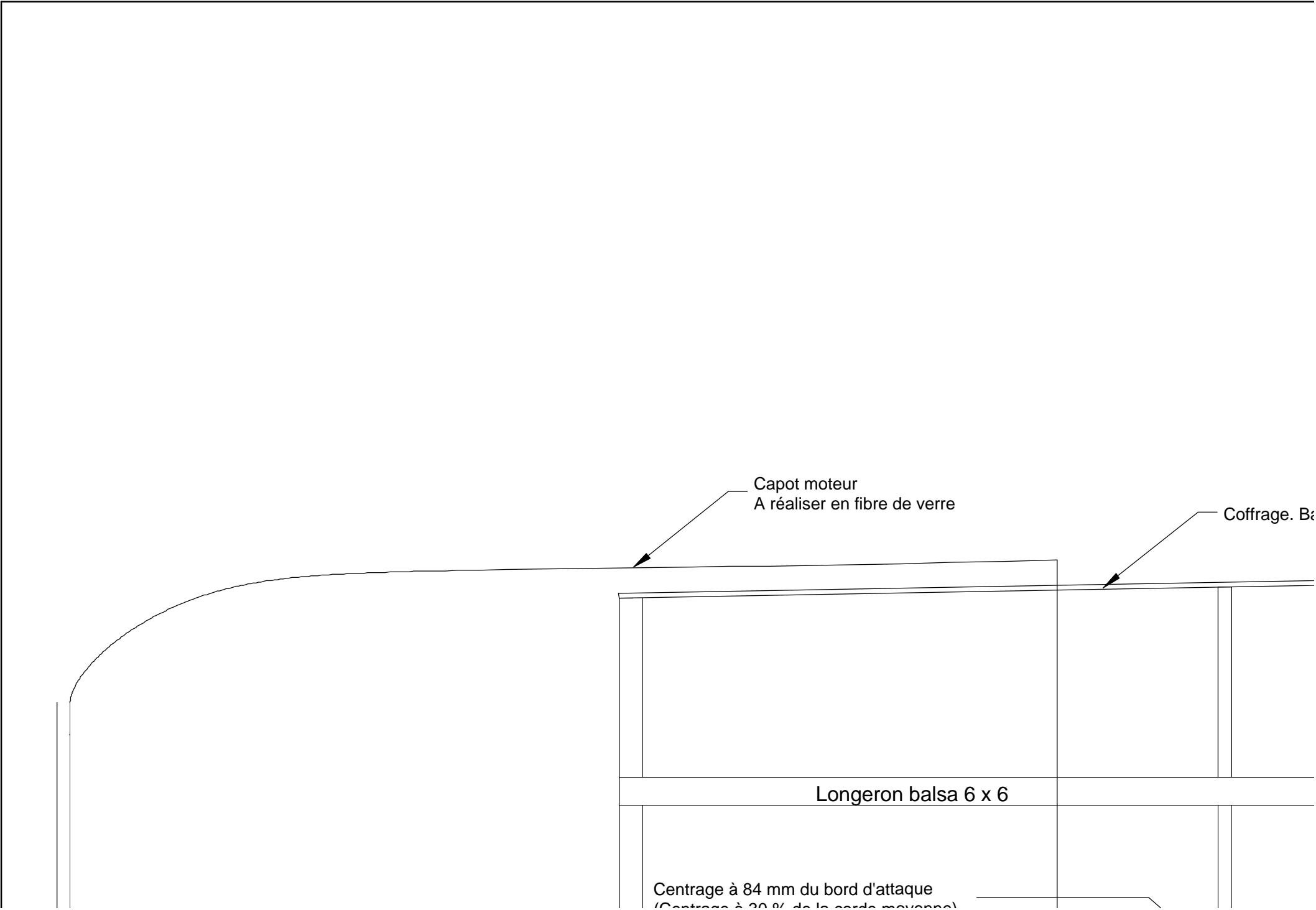

alsa roulé 15/10

C9

Verrière thermoformée

C8

Longeron b

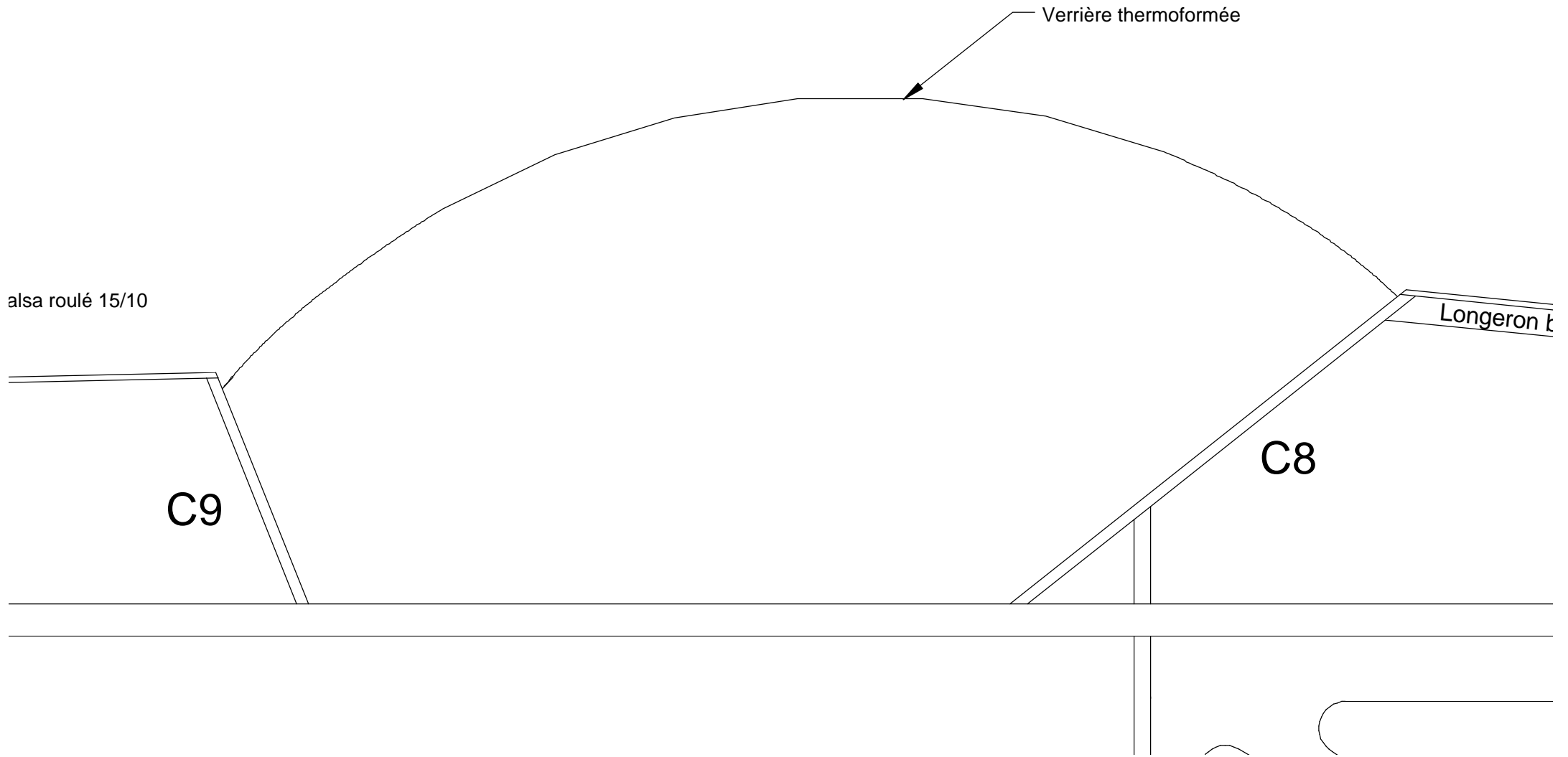

Coffrage. Balsa roulé 15/10

balsa 5 x 5

C7

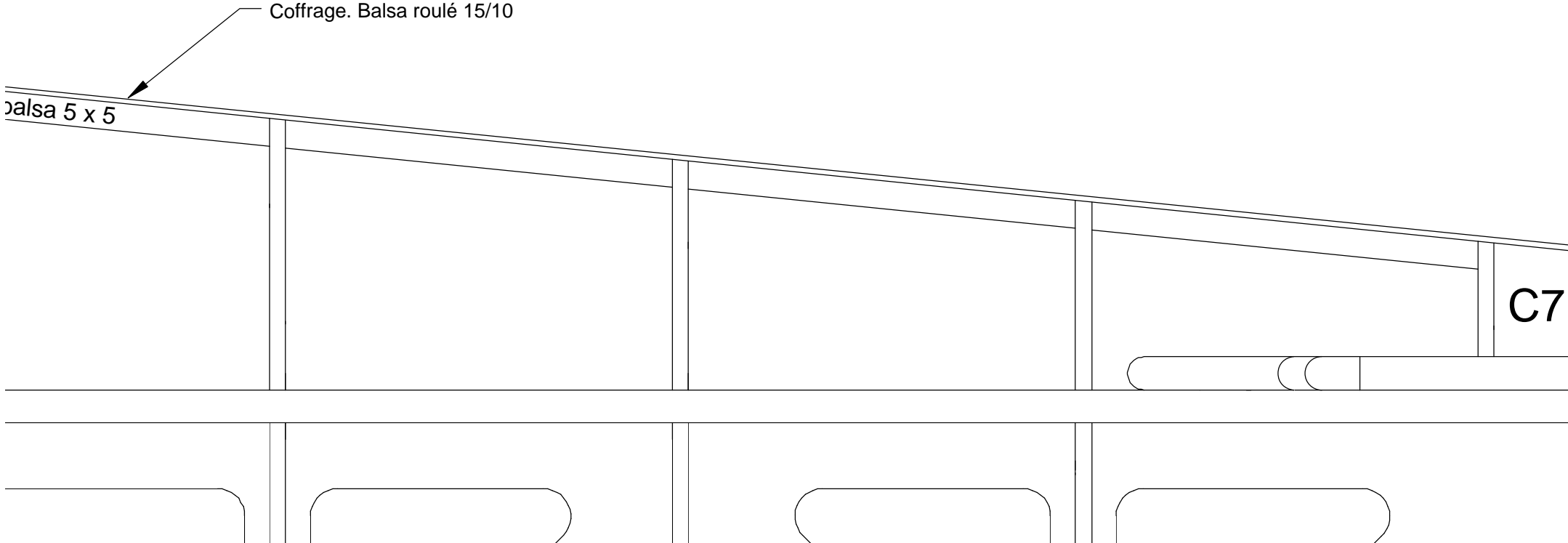

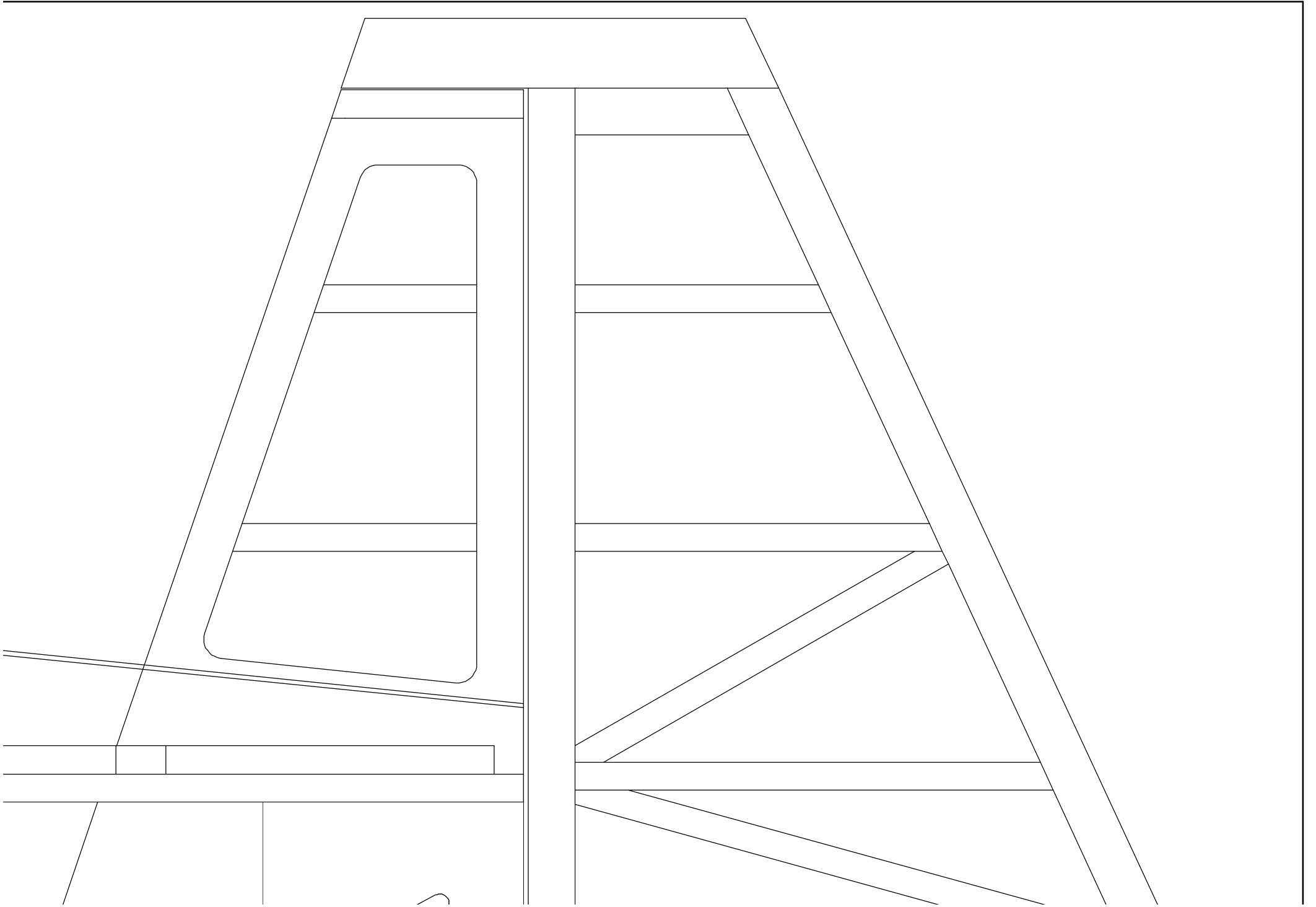

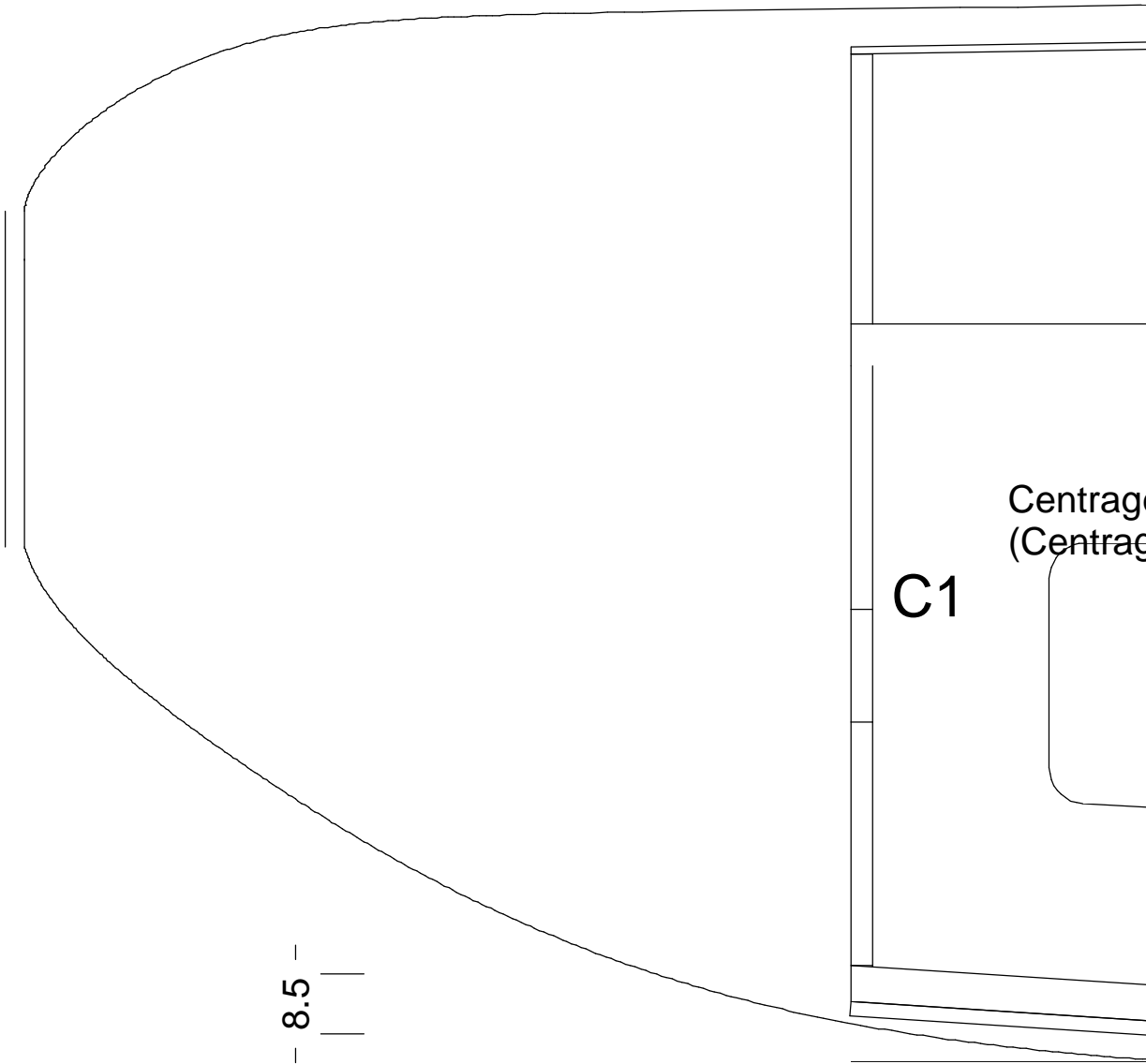

- 8.5 -

C1

Centragi
(Centragi)

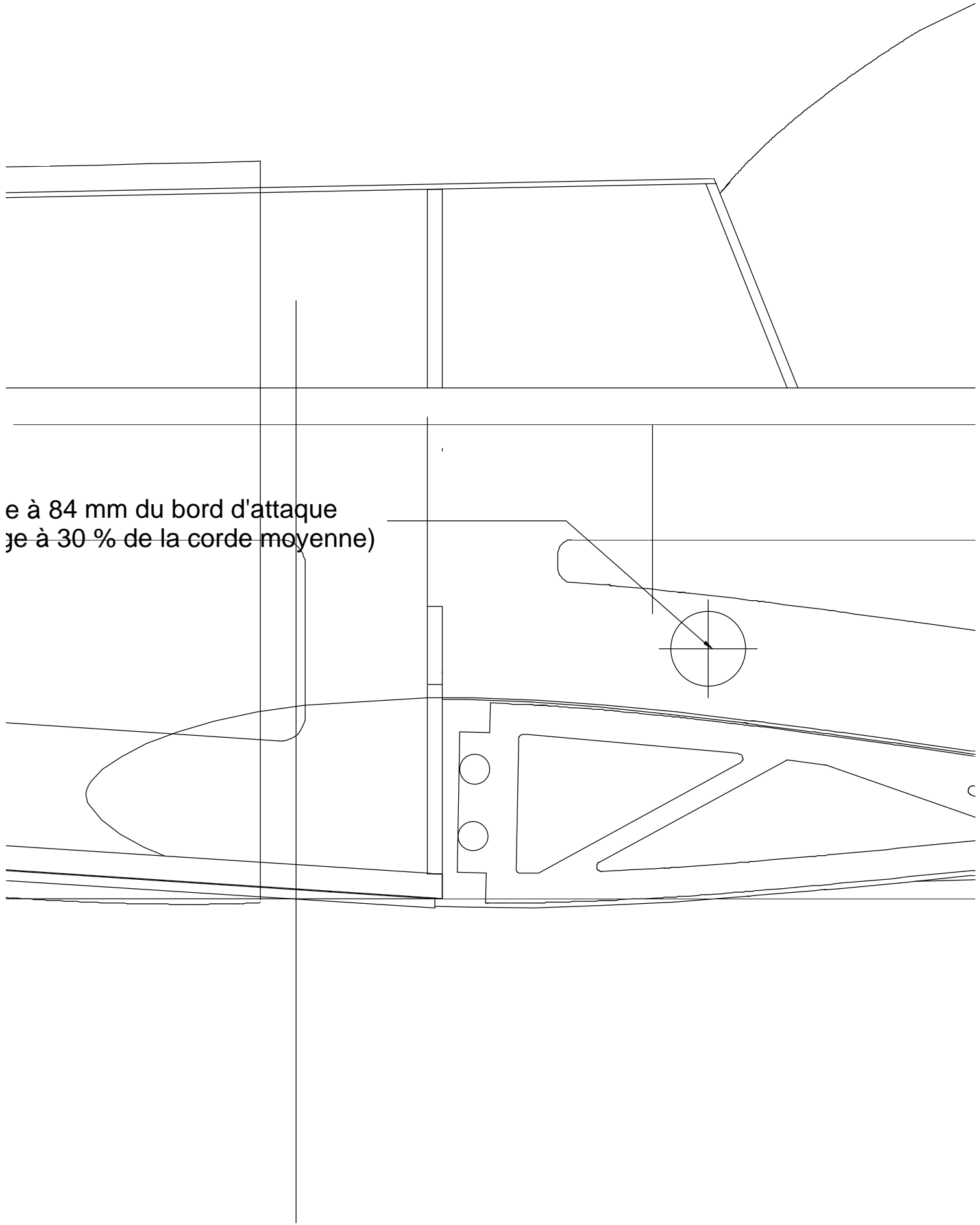

e à 84 mm du bord d'attaque
je à 30 % de la corde moyenne)

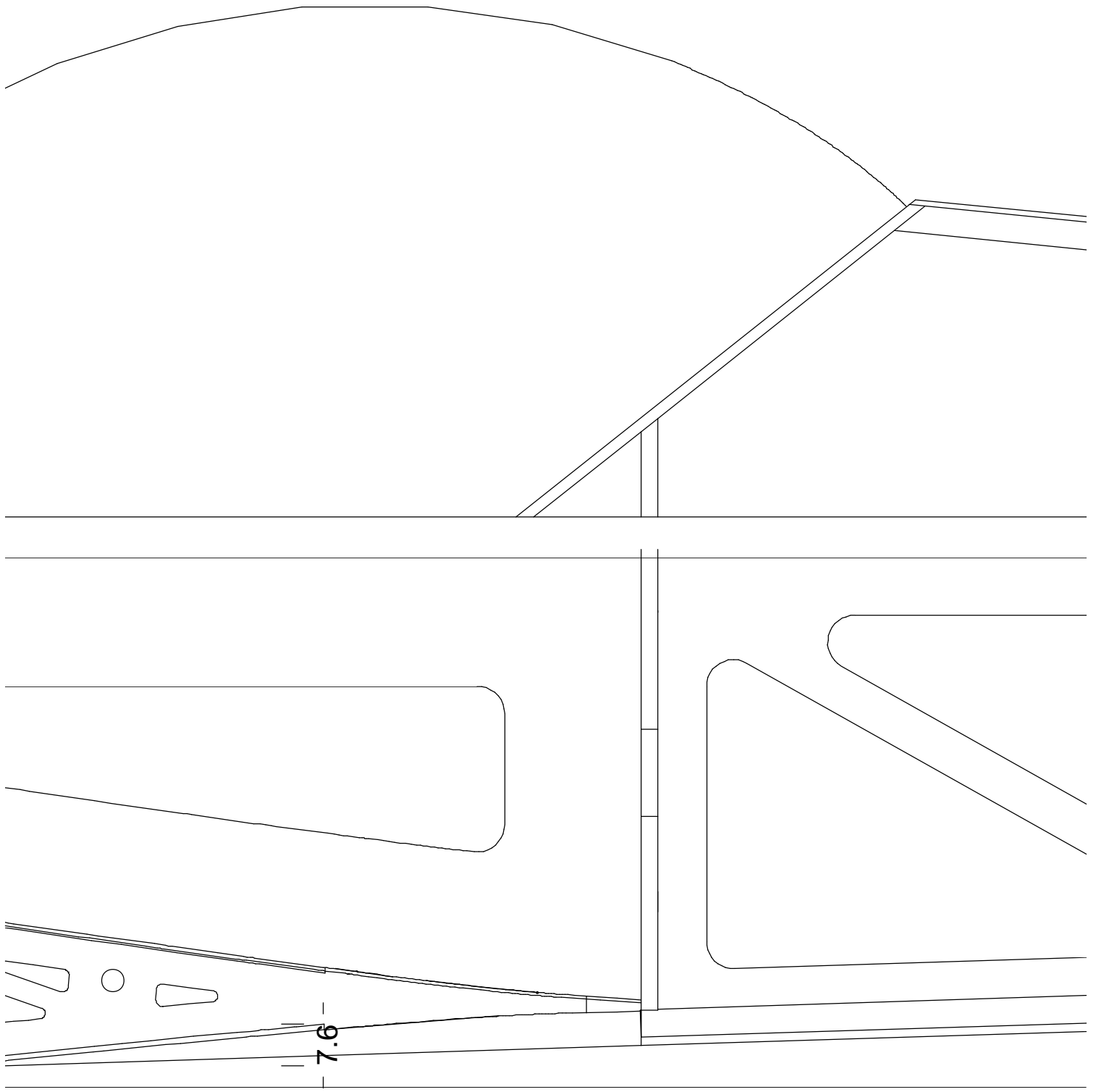

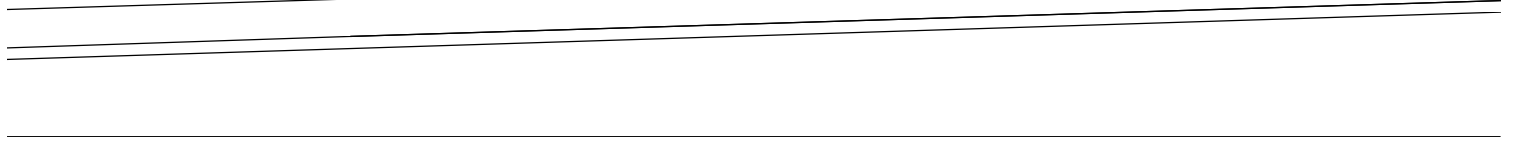
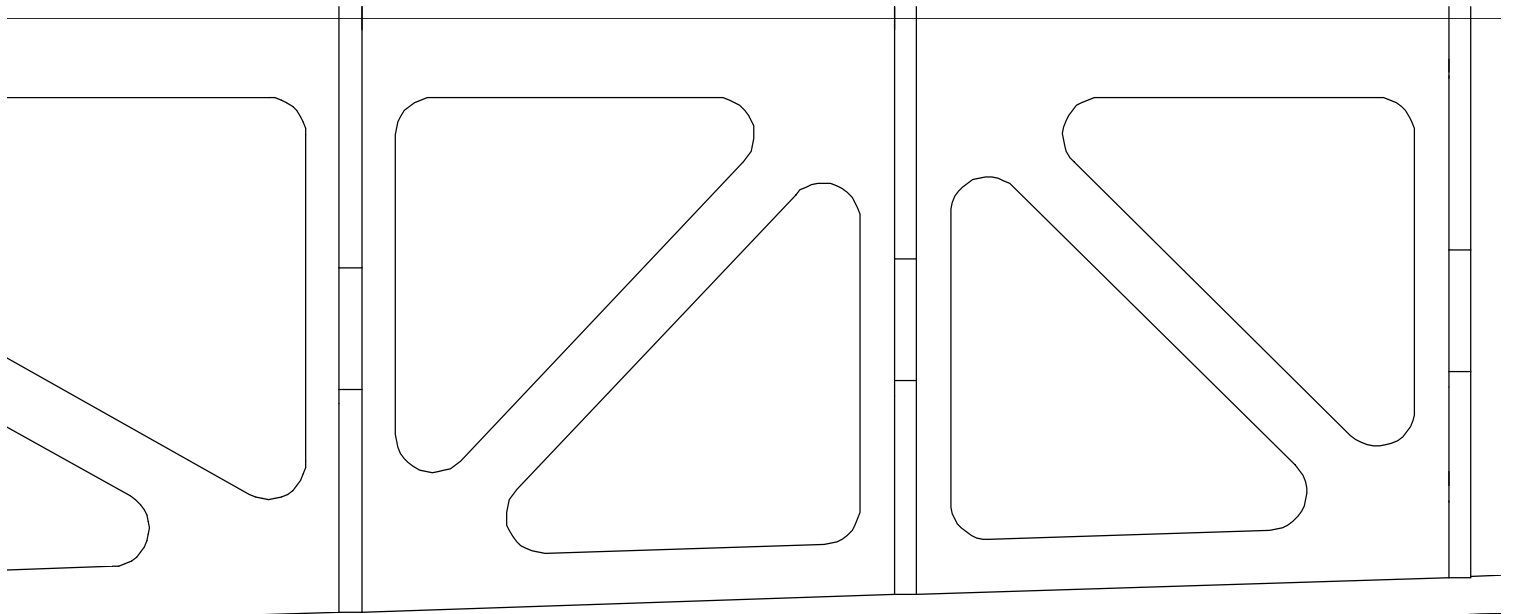
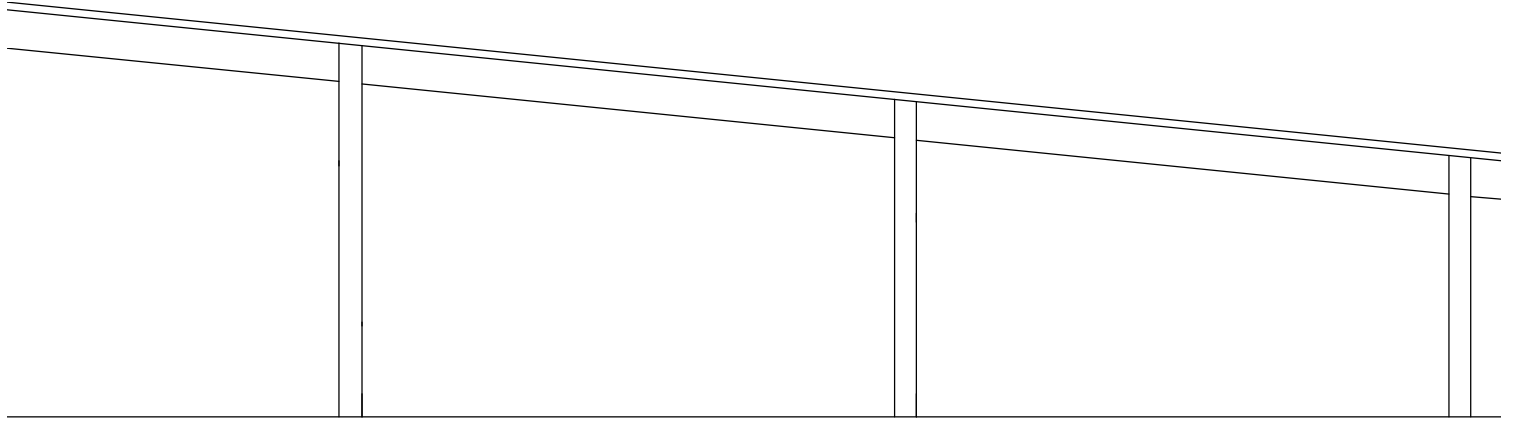

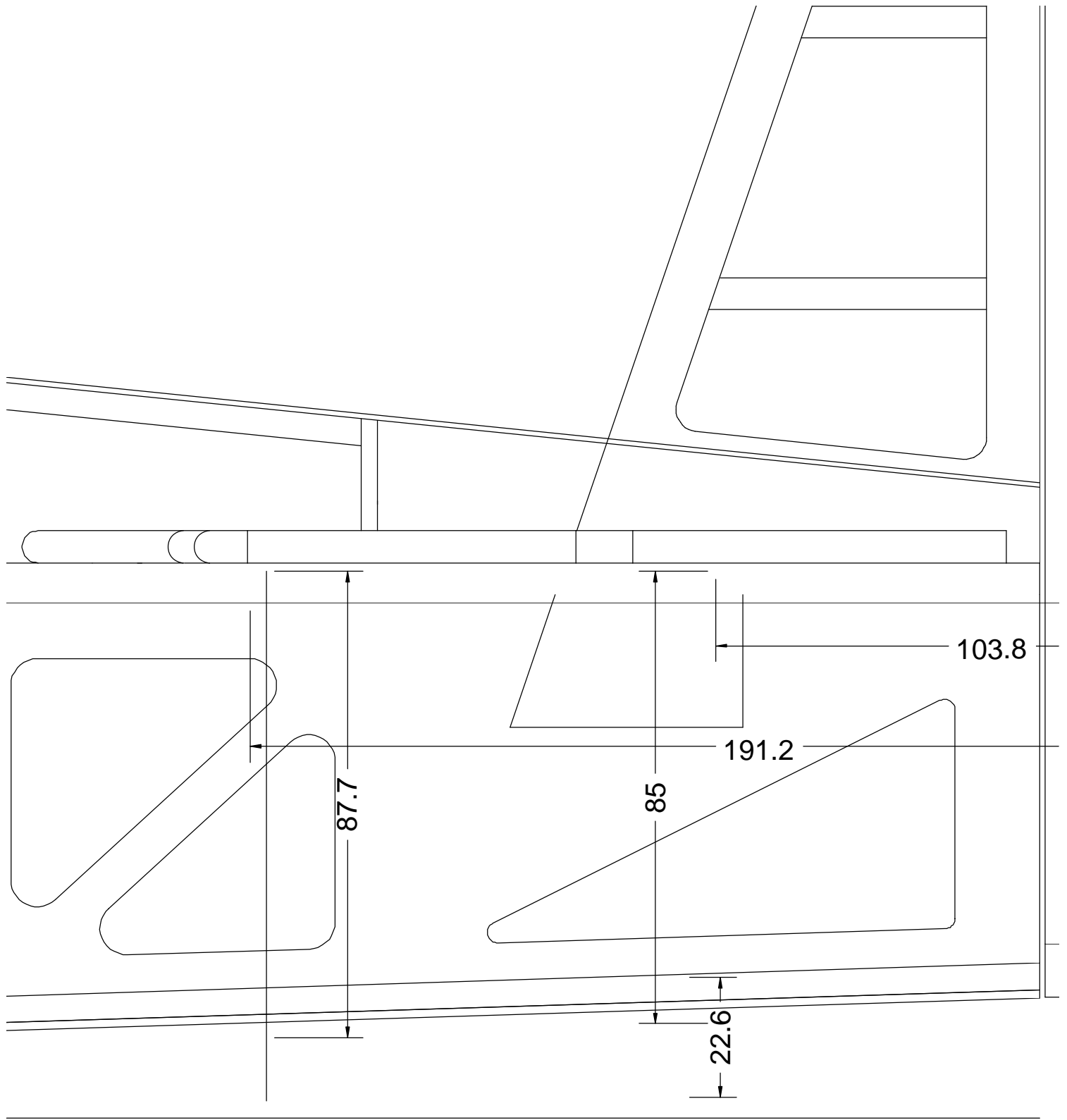

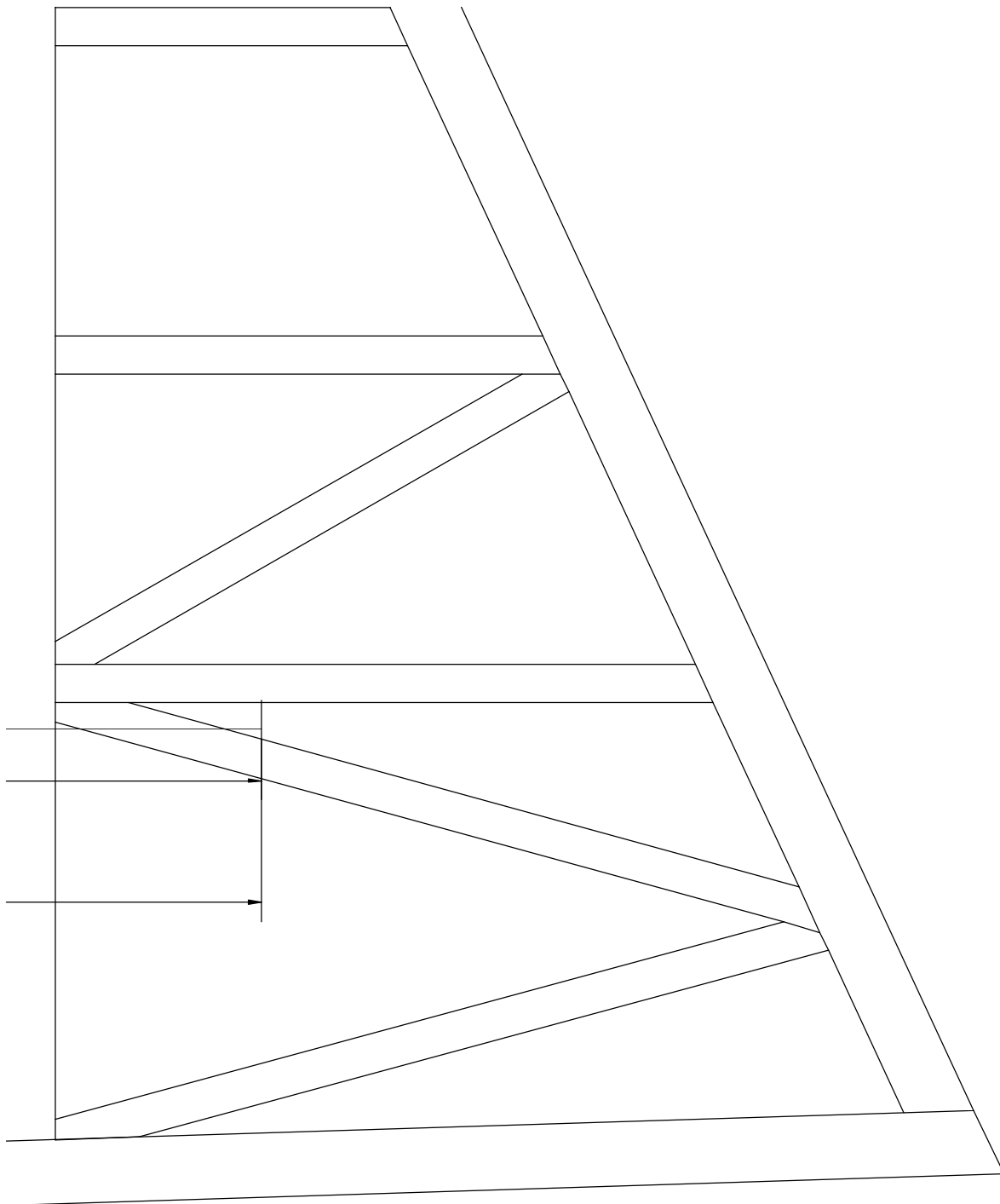

Cap 232 semi maquette

Envergure: 127 cm
Surface ailaire: 30 dm²
Charge ailaire: 70g/dm²
Masse: 1800 - 2000 g
Moteur: Thermique classe 40 ou électrique

Vues fuselage

Echelle: 1/1

Année: 2003

Conception & Dessin: Jean-françois Thier

Contact: <http://www.aerosquare.com>

copyright © 2003 J-F Thier. Toute utilisation commerciale strictement interdite sans accord préalable

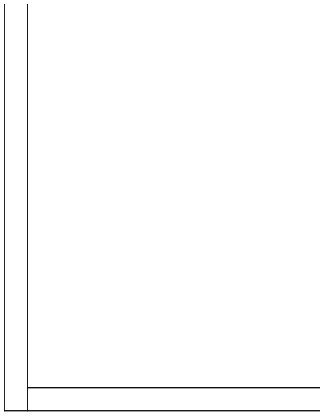

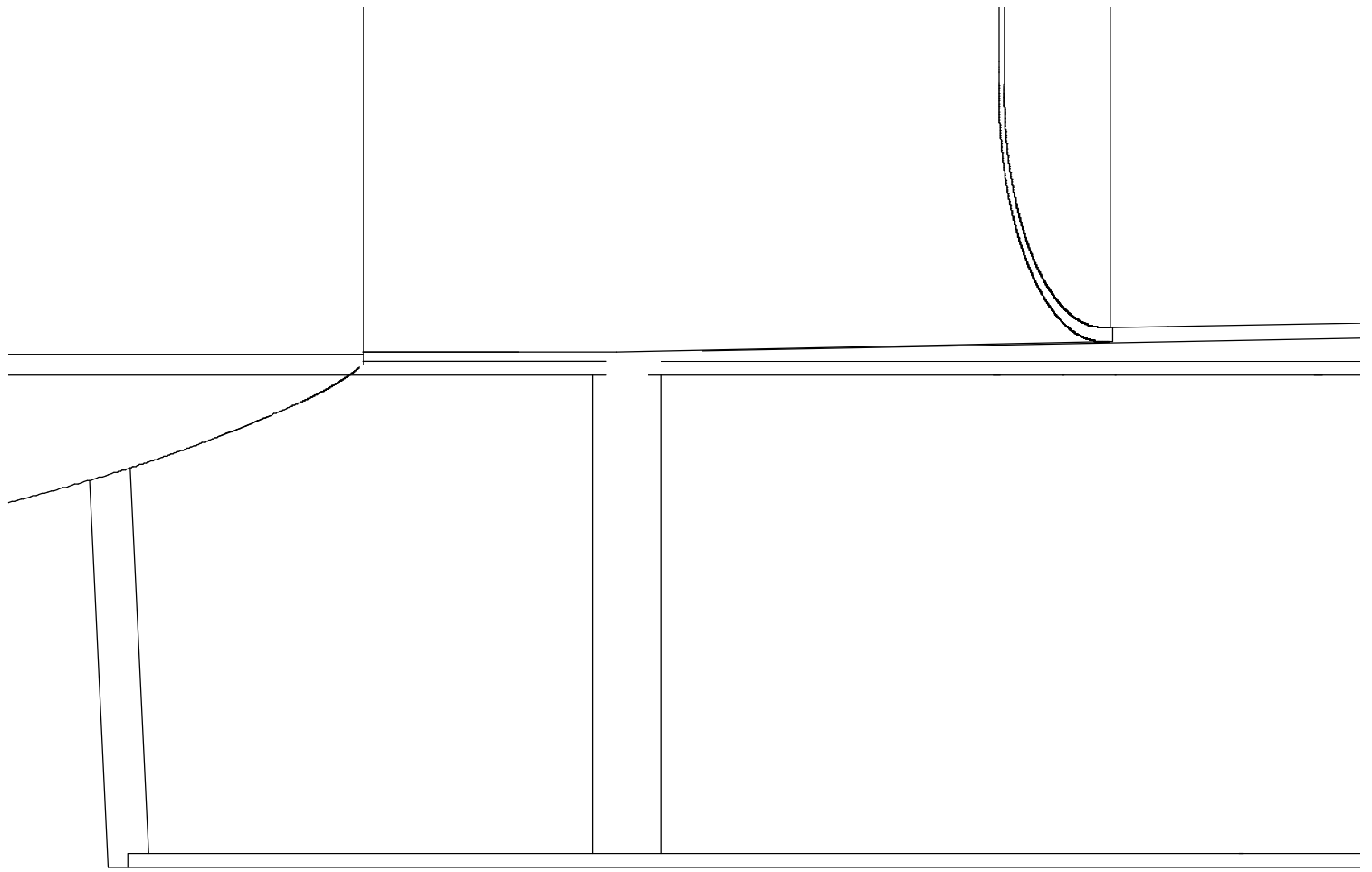

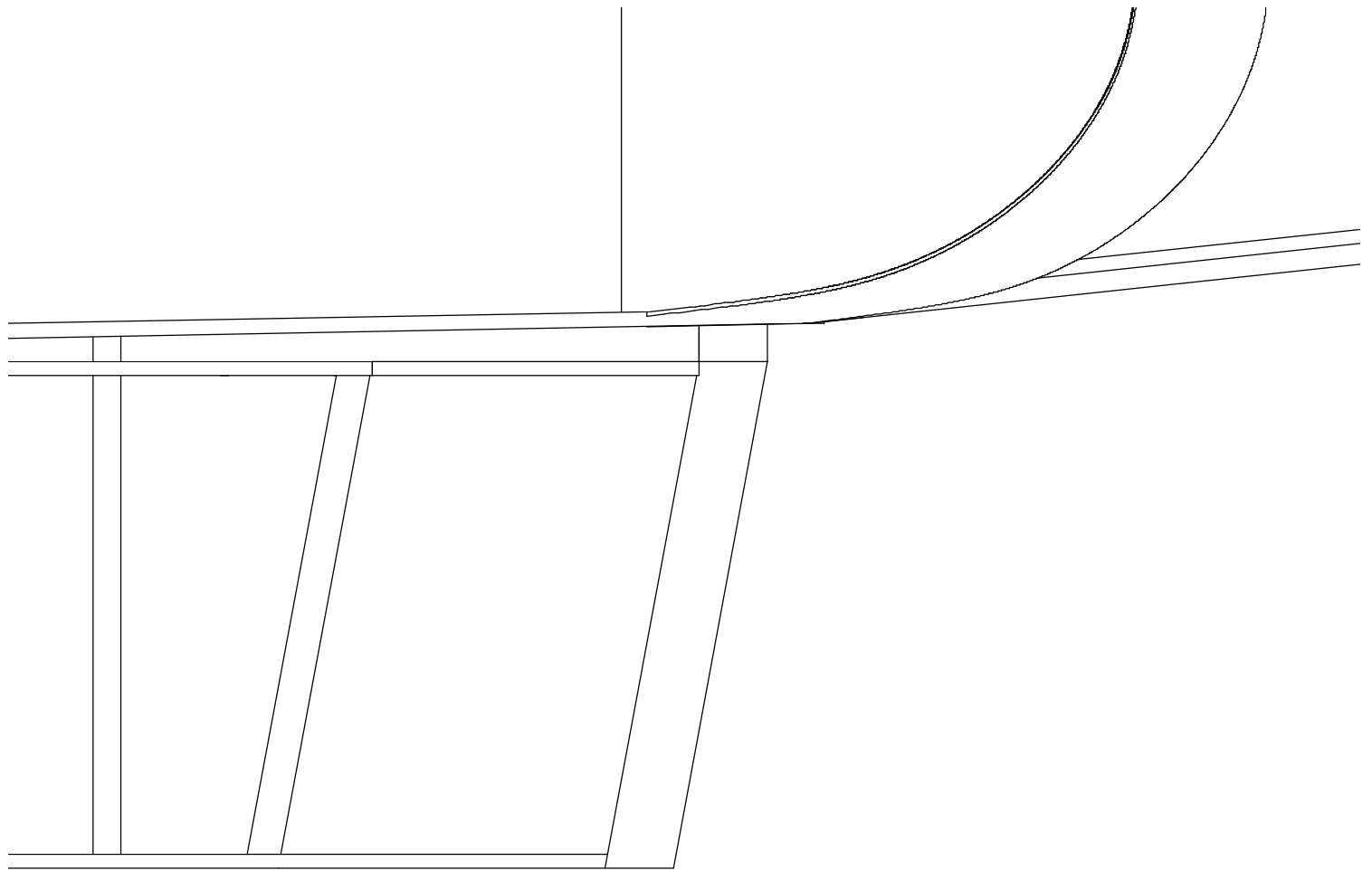

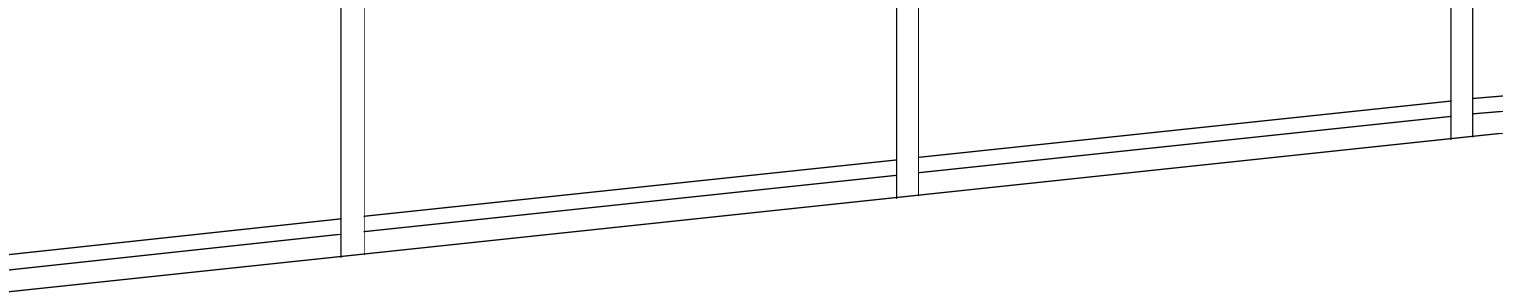

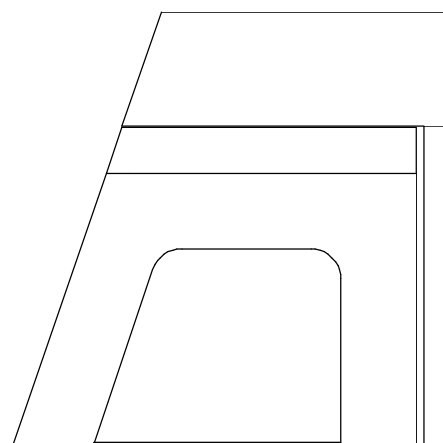
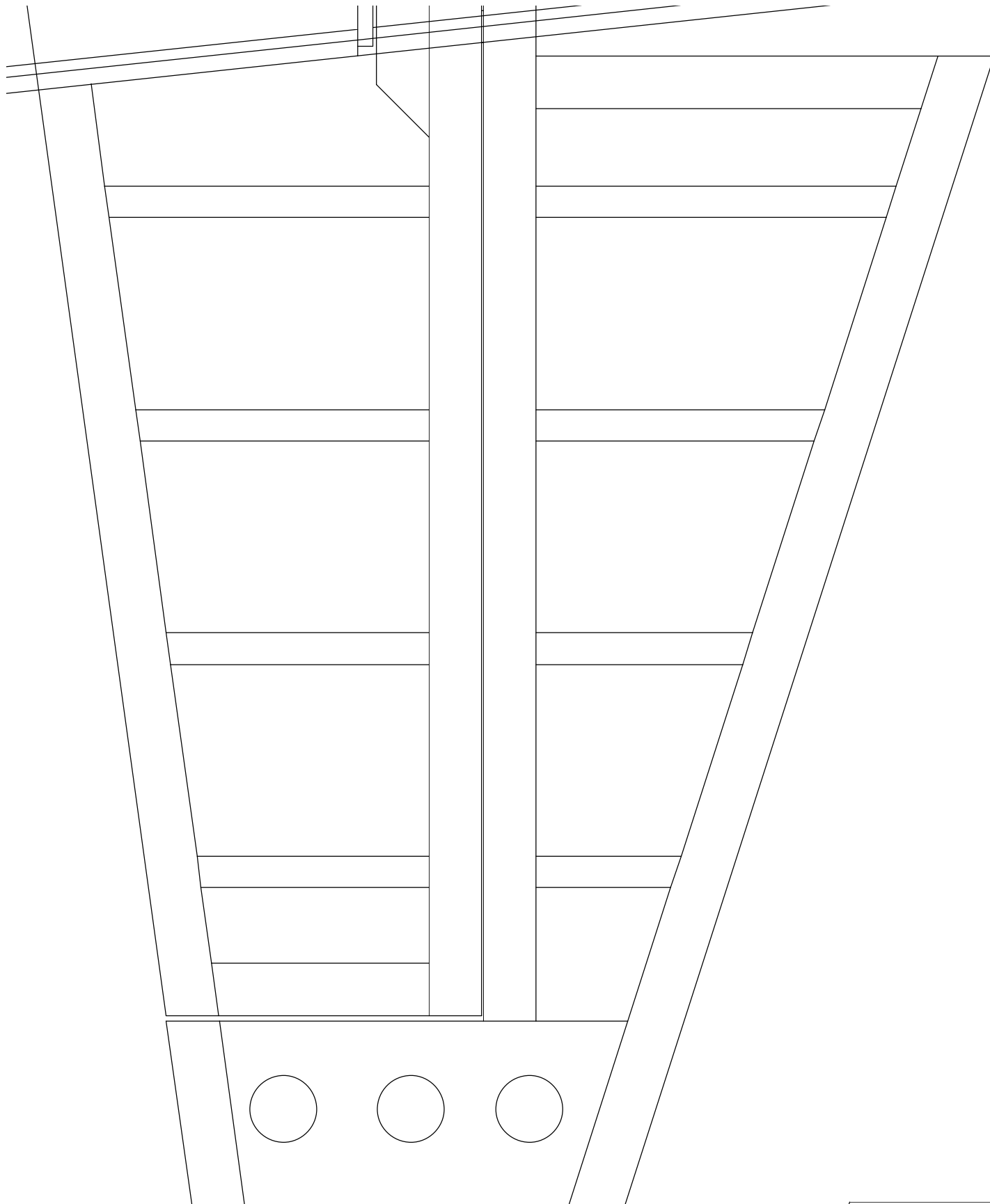

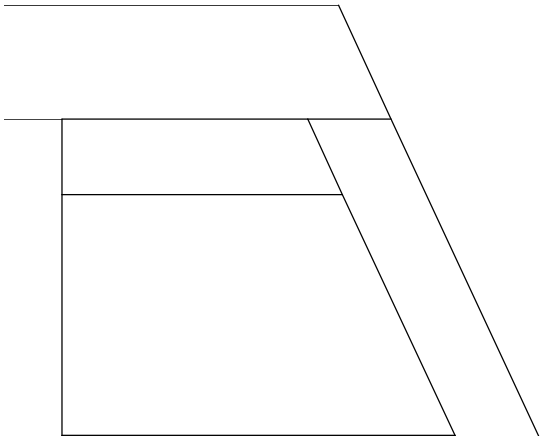

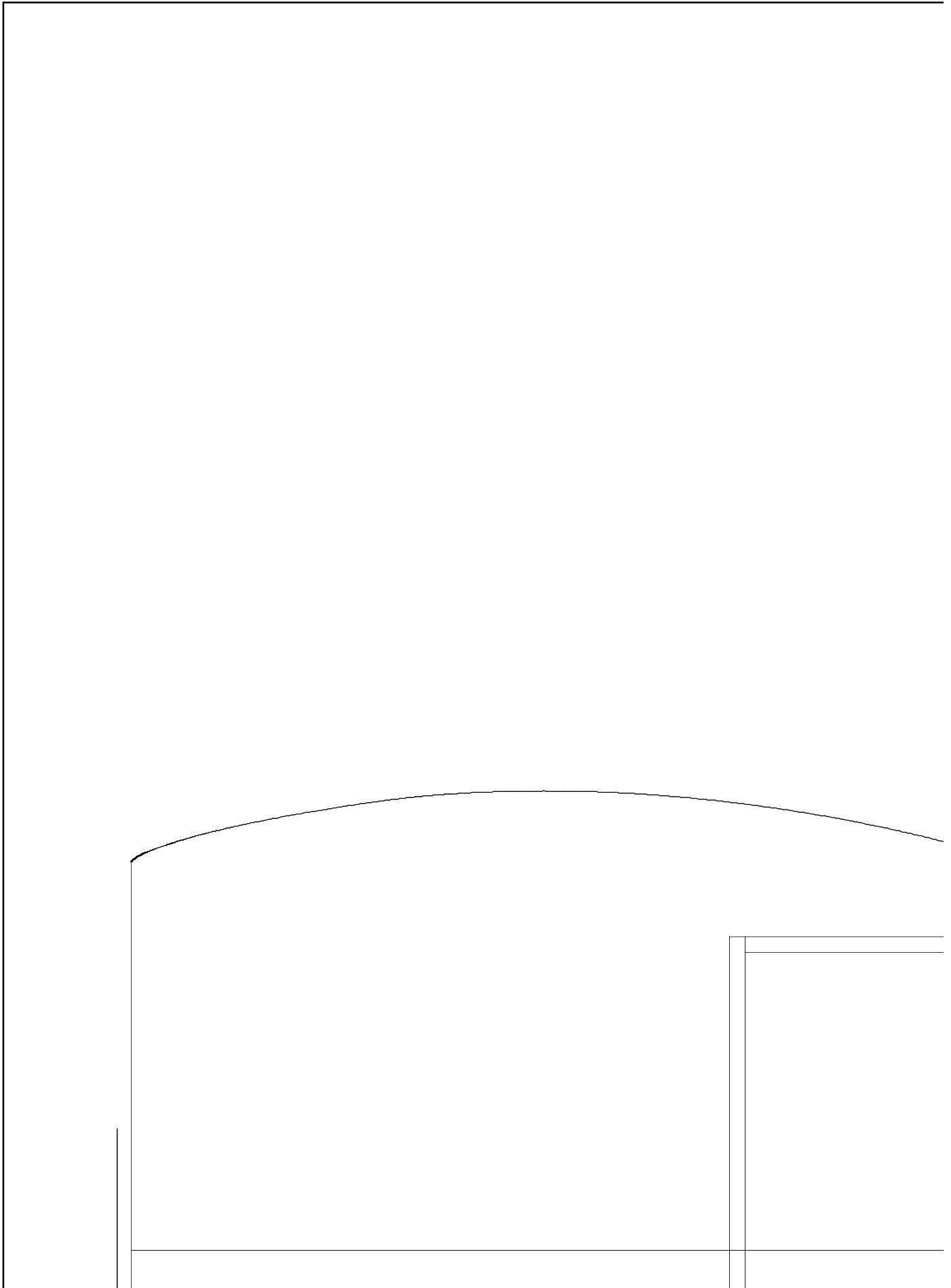

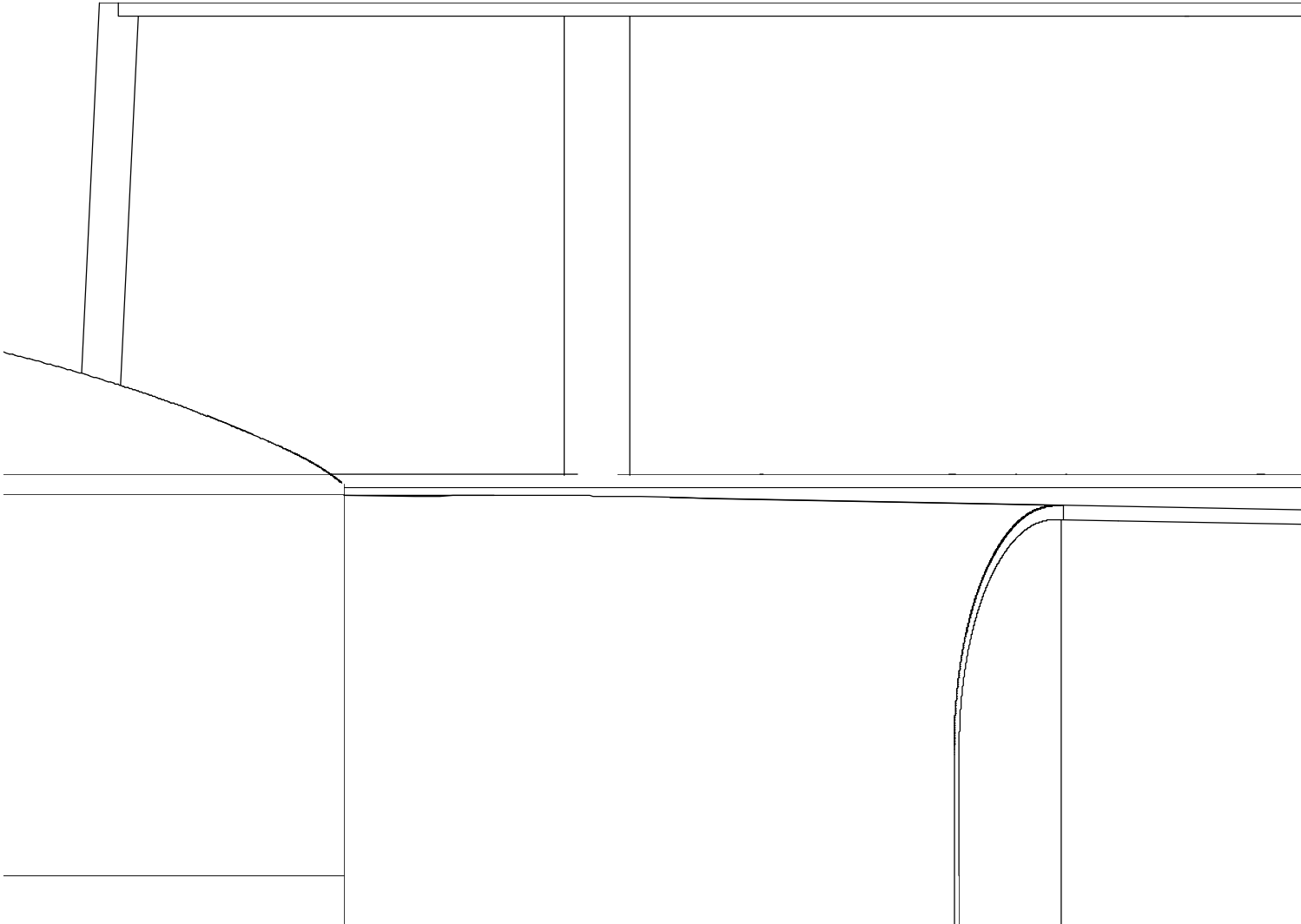

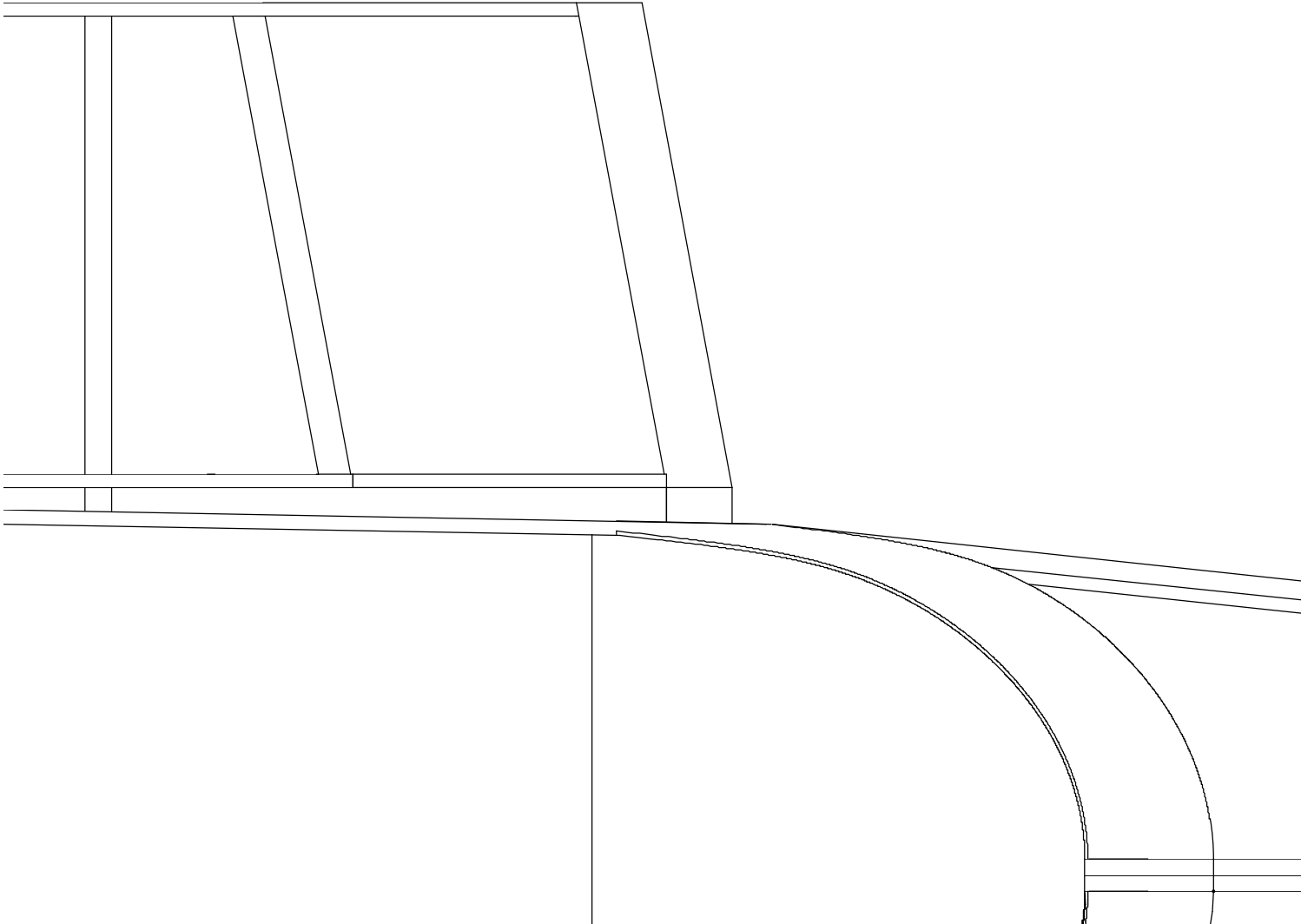

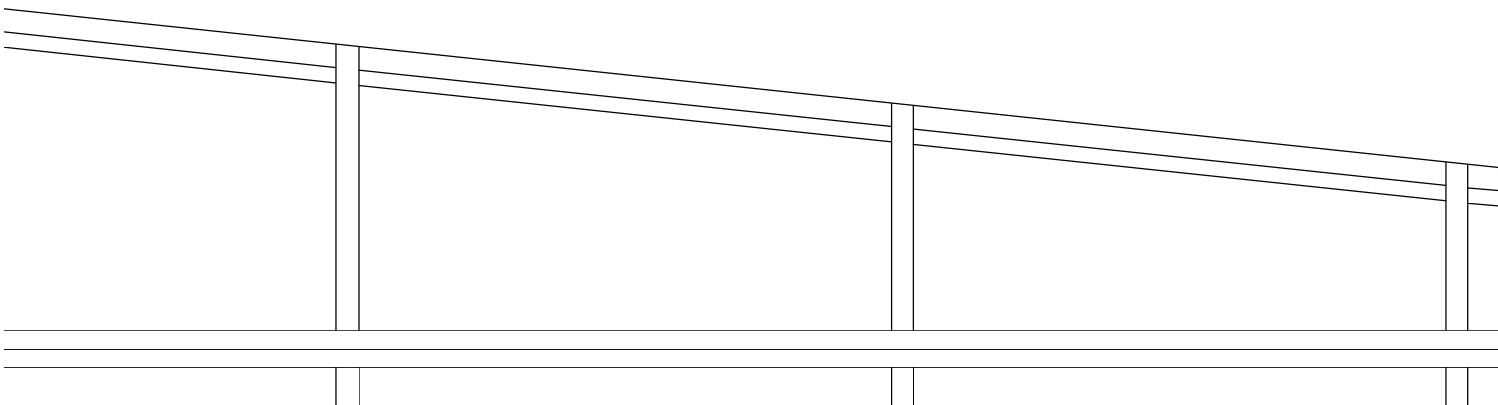

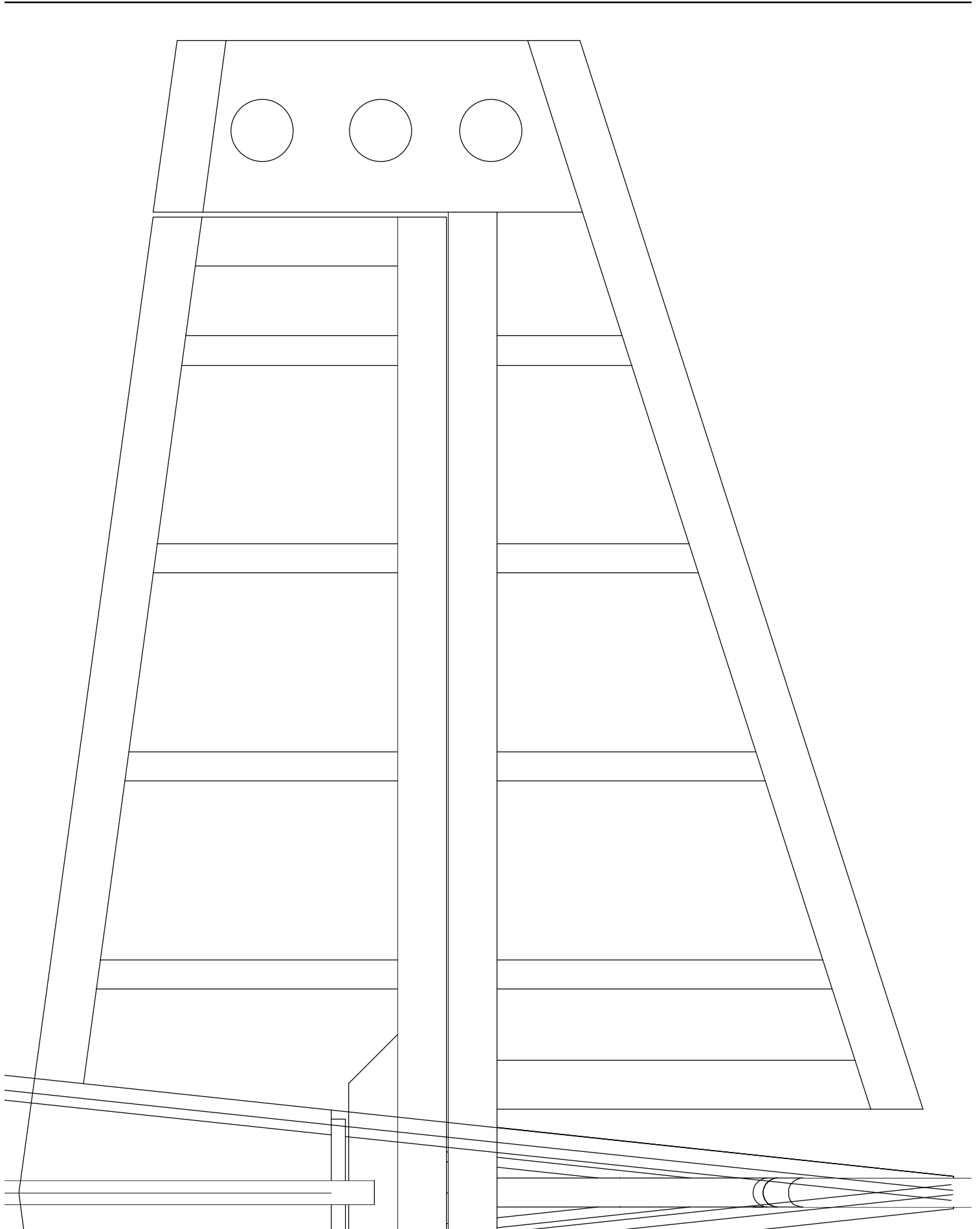

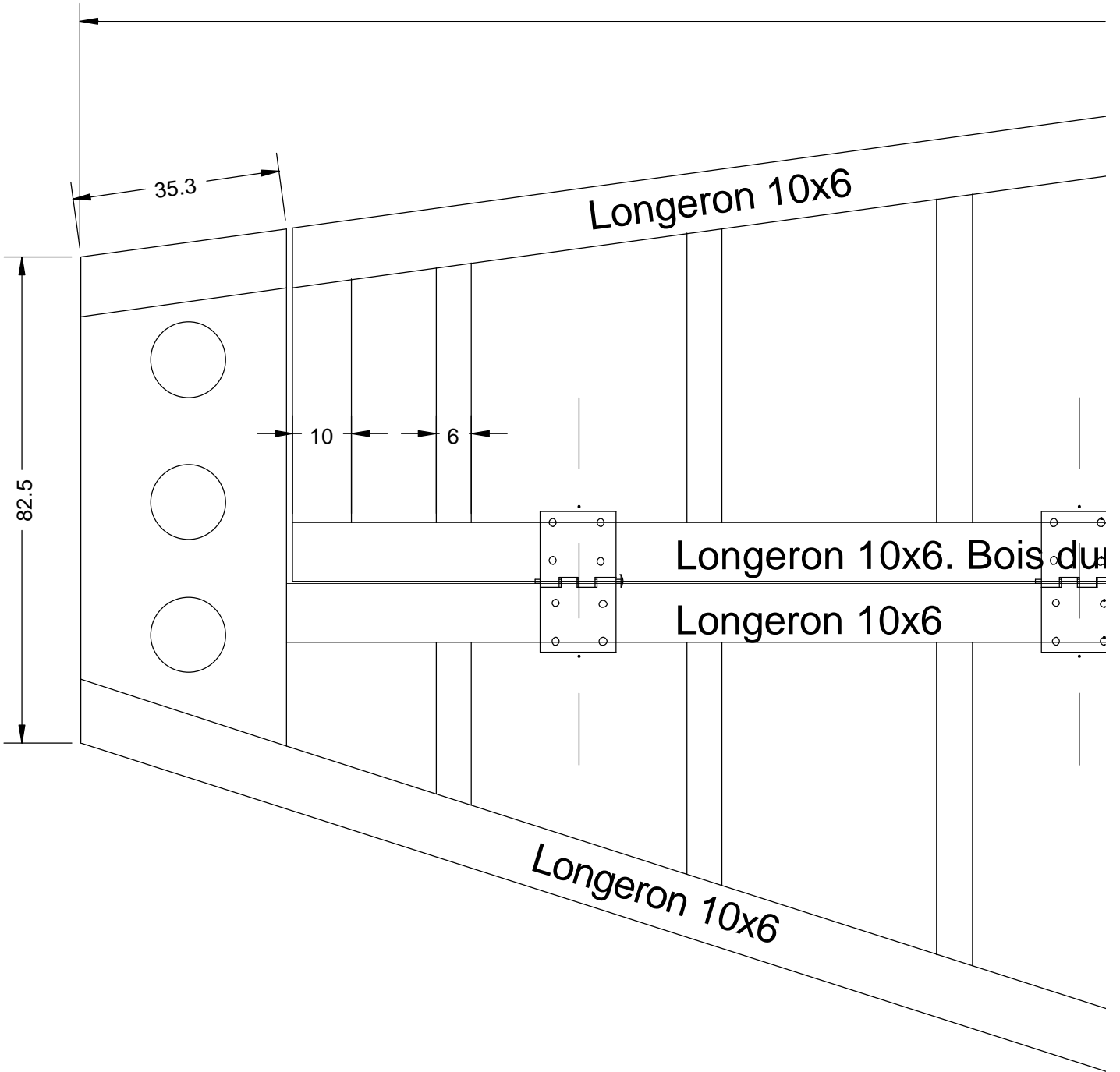

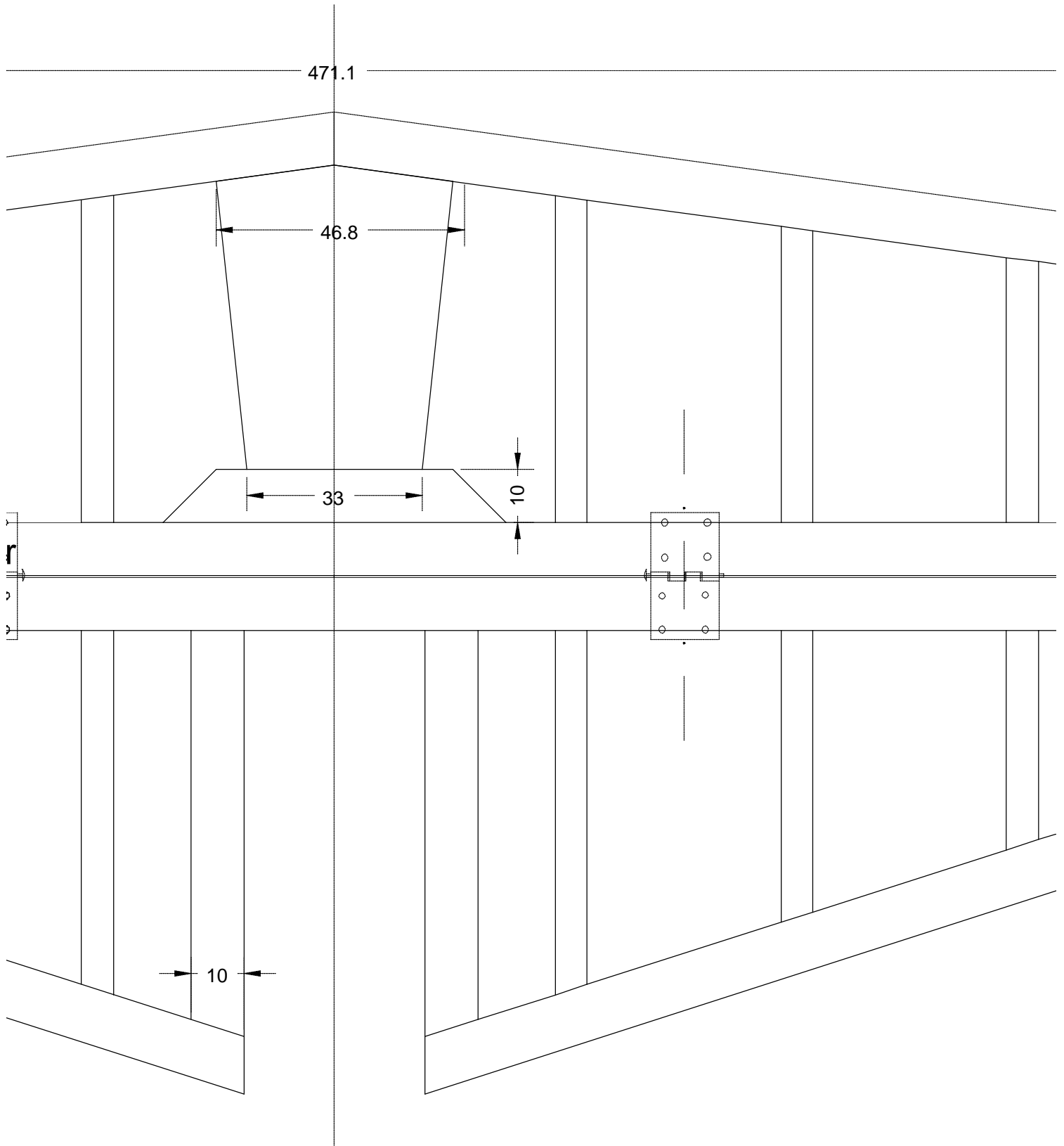
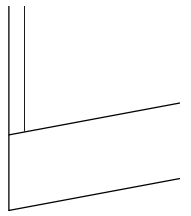

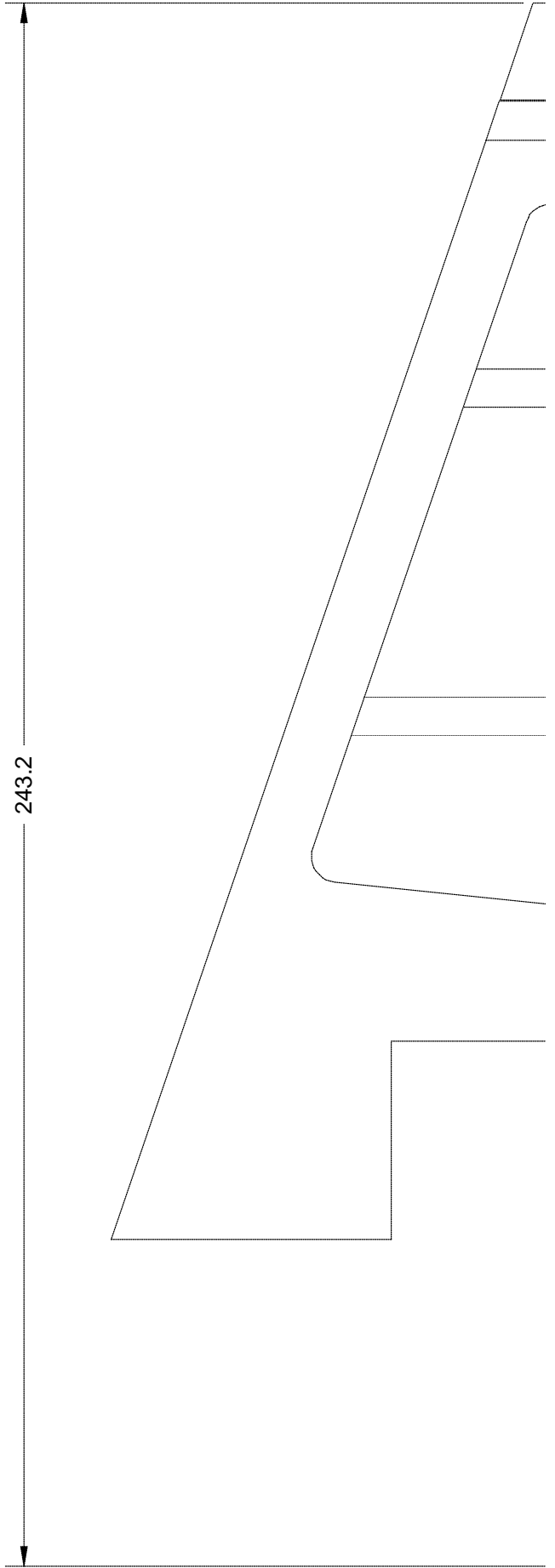
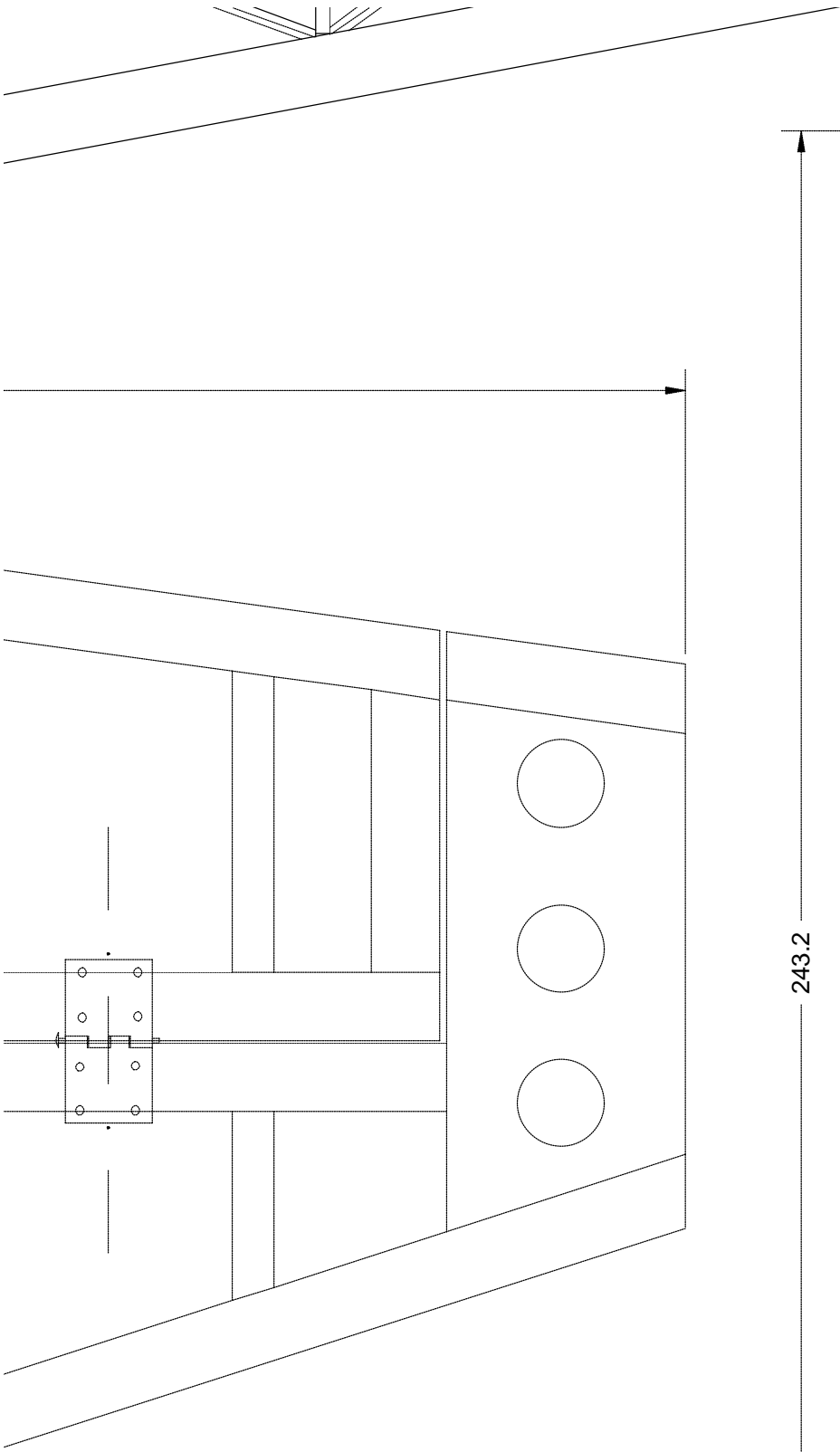

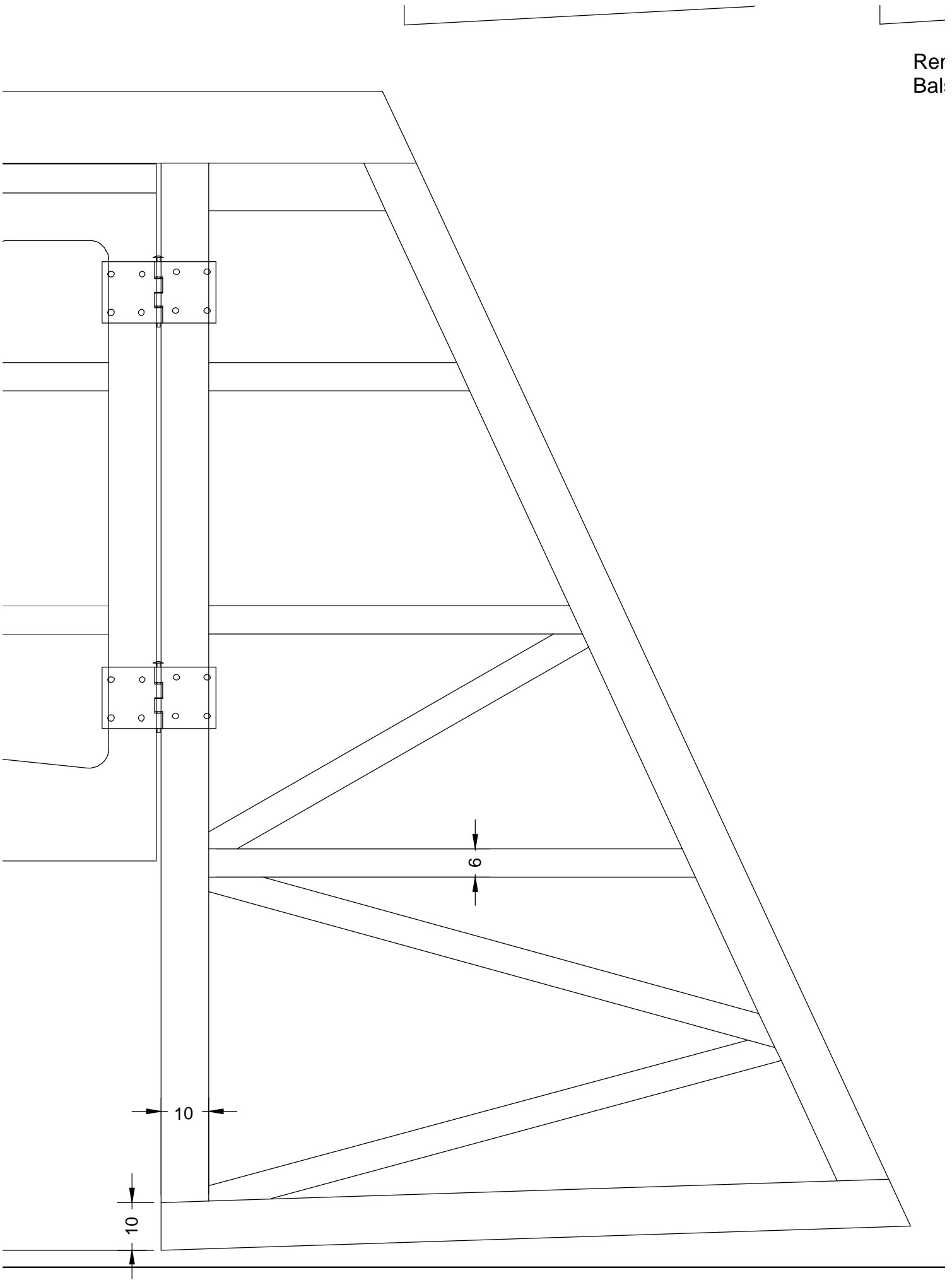

renforts diagonaux aileron
sa 20/10

Cap 232 semi maquette

Envergure: 127 cm
Surface ailaire: 30 dm²
Charge ailaire: 70g/dm²
Masse: 1800 - 2000 g
Moteur: Thermique classe 40 ou électrique

Plan aile et empennages

Echelle: 1/1

Année: 2003

Conception & Dessin: Jean-françois Thier

Contact: <http://www.aerosquare.com>

copyright © 2003 J-F Thier. Toute utilisation commerciale strictement interdite sans accord préalable

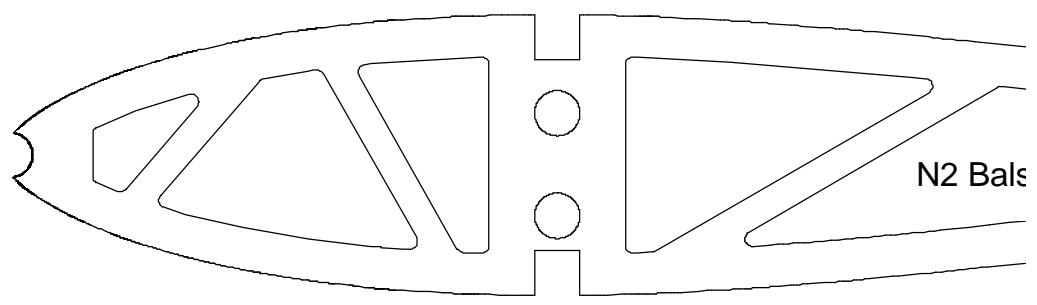
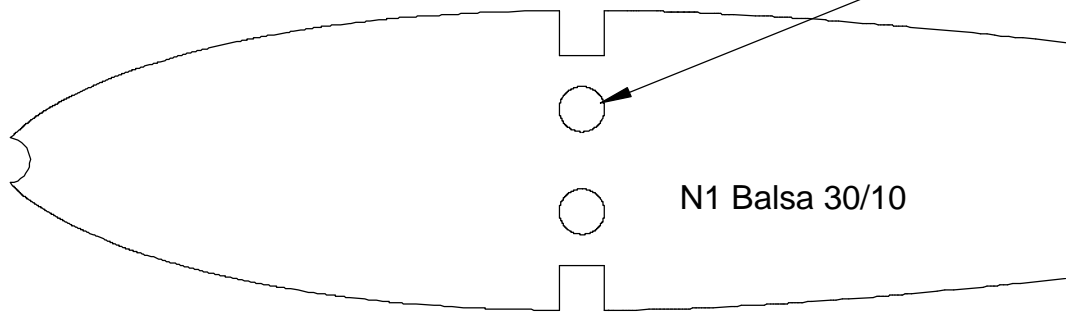
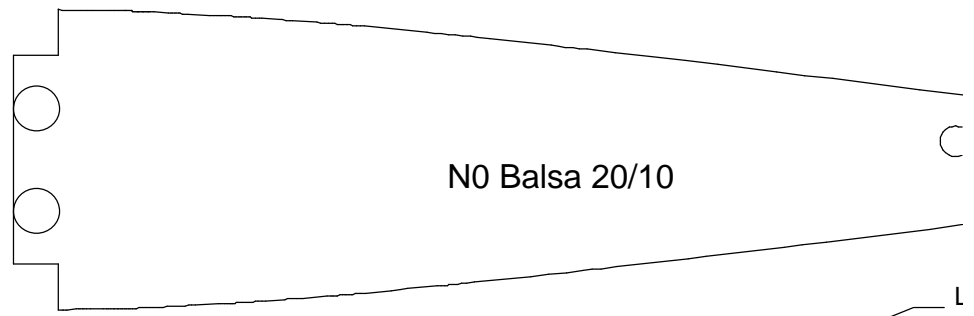
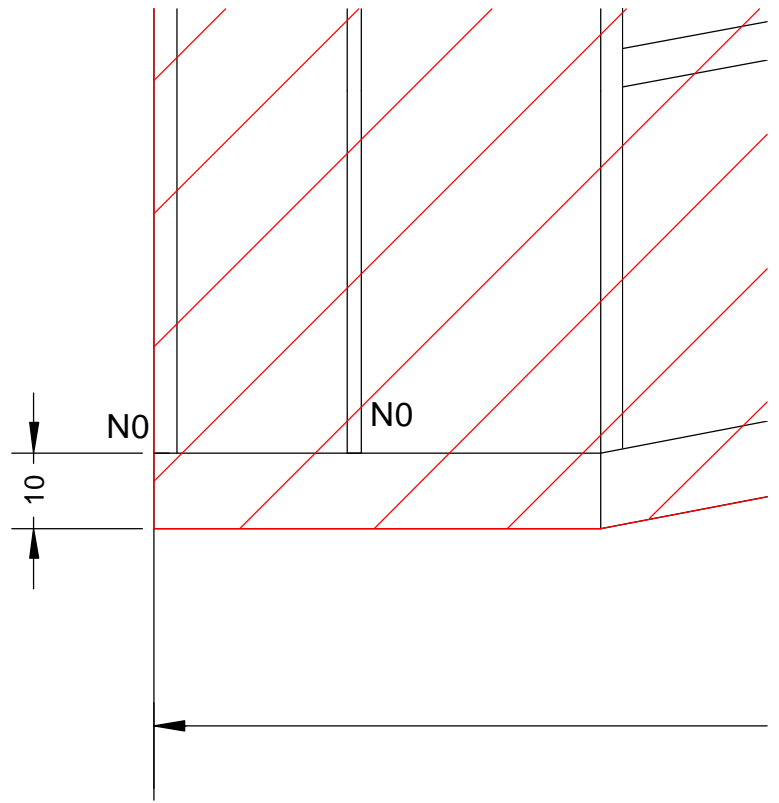

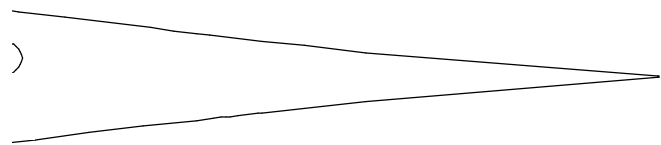
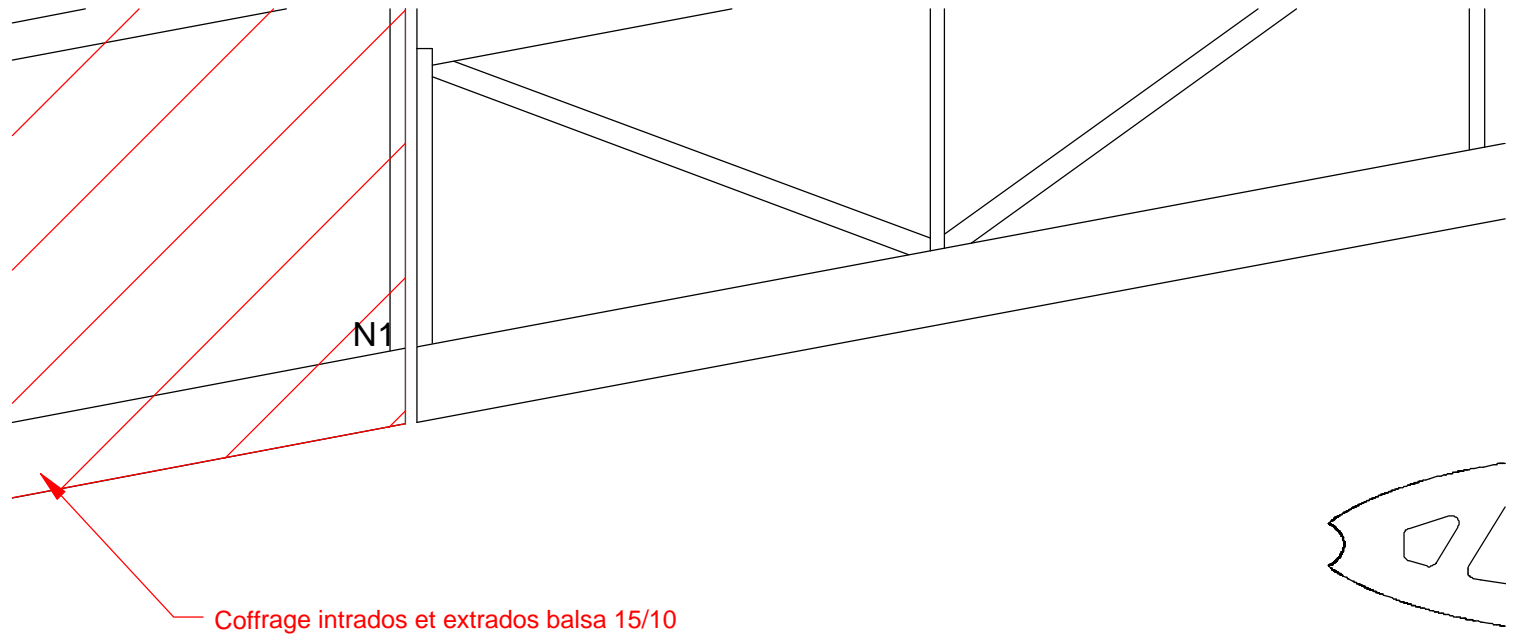

La clé d'aile est constituée de 2 longerons carbone Ø 6 mm

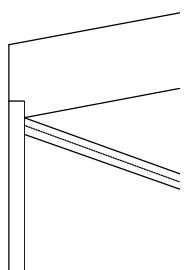
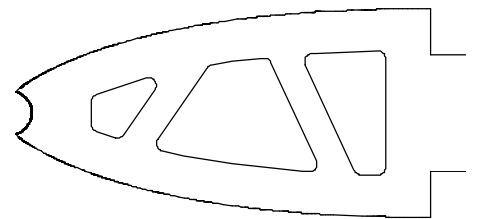
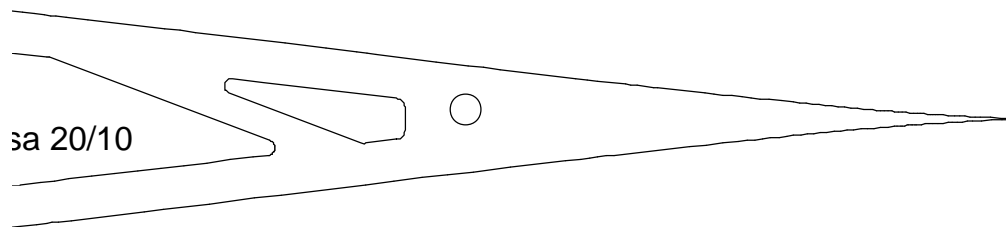
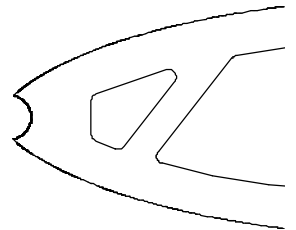
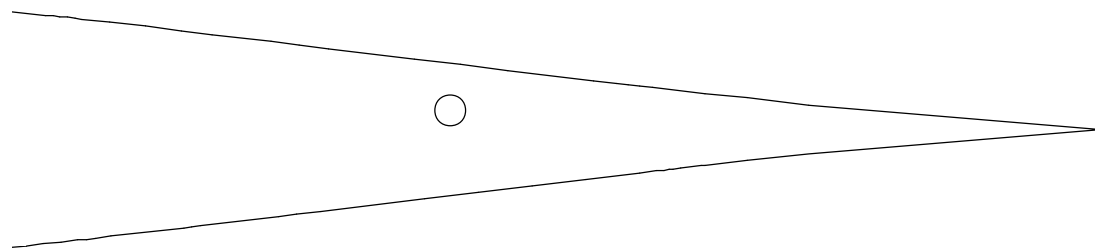
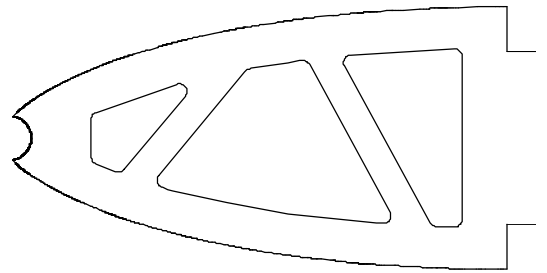

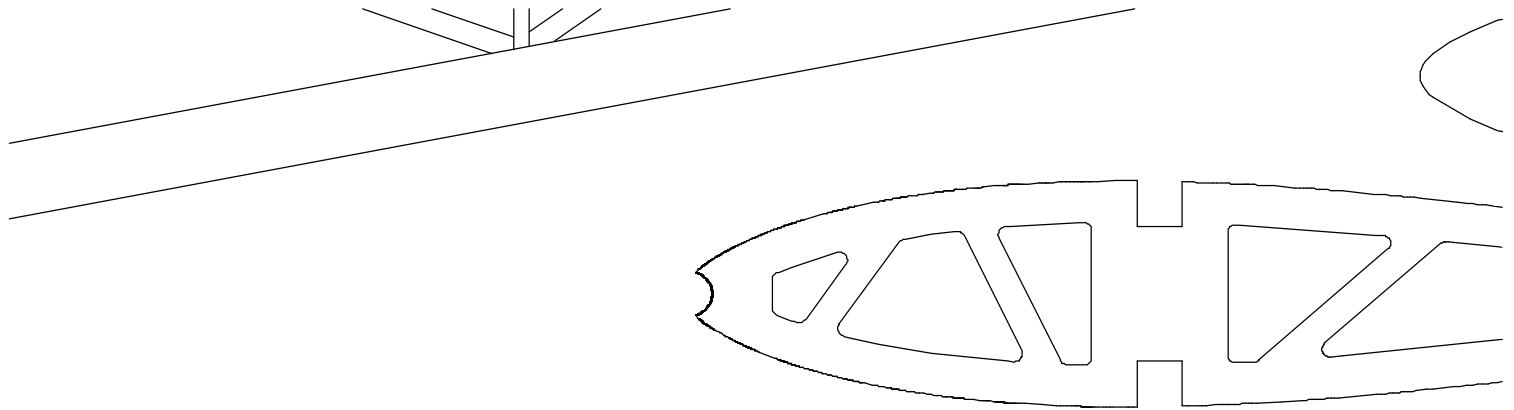

N6 E

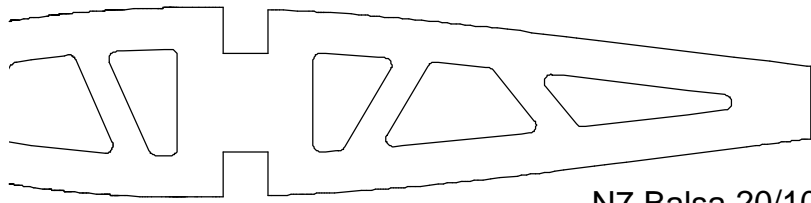

N7 Balsa 20/10

638.2

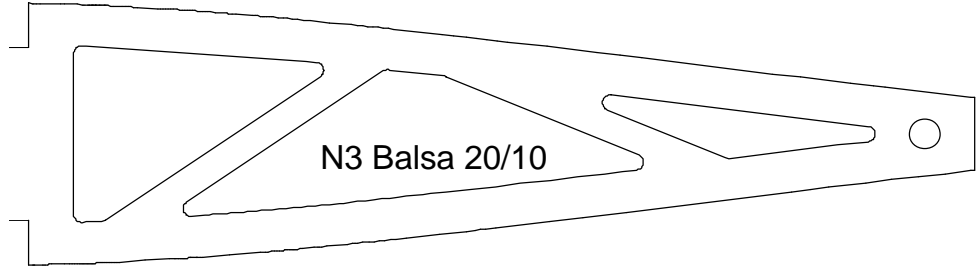

N3 Balsa 20/10

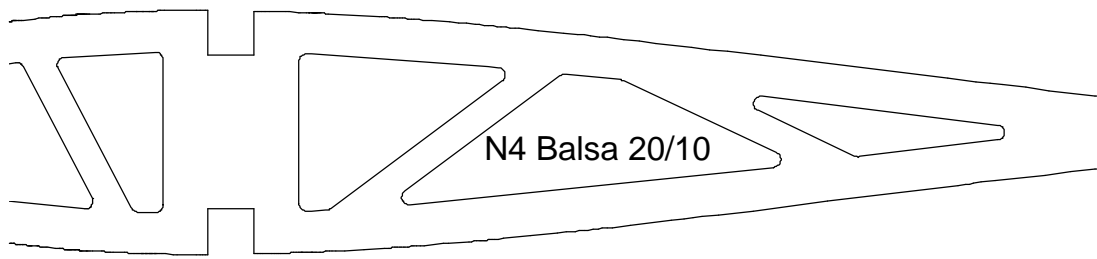

N4 Balsa 20/10

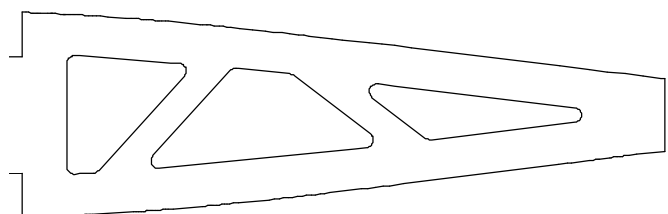

N5 Balsa 20/10

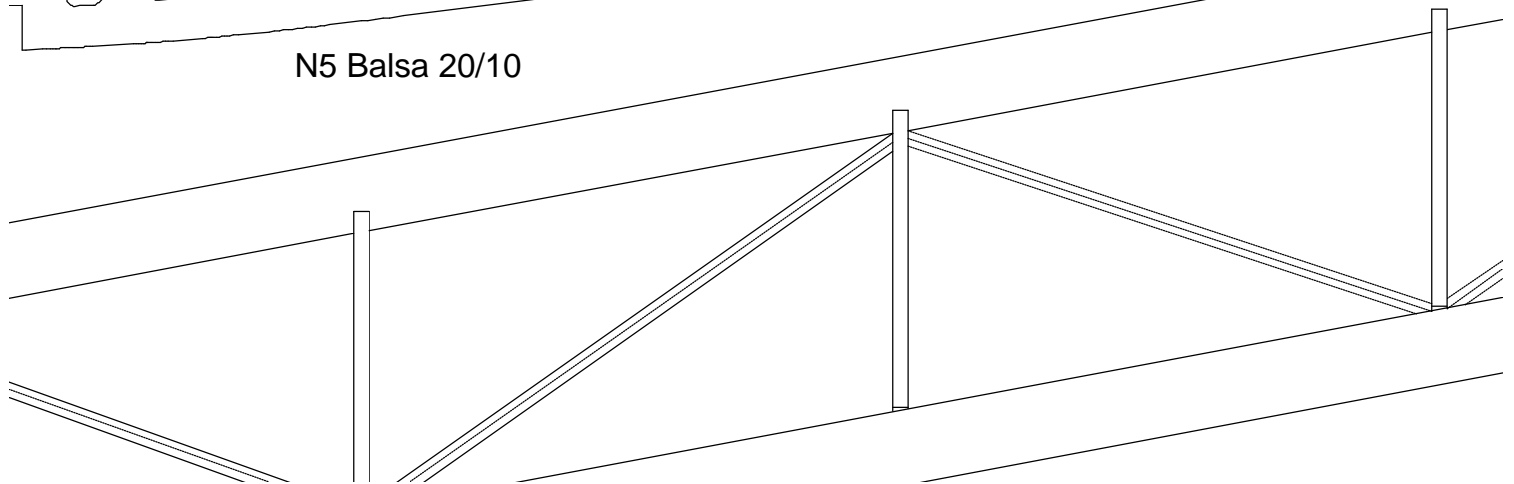

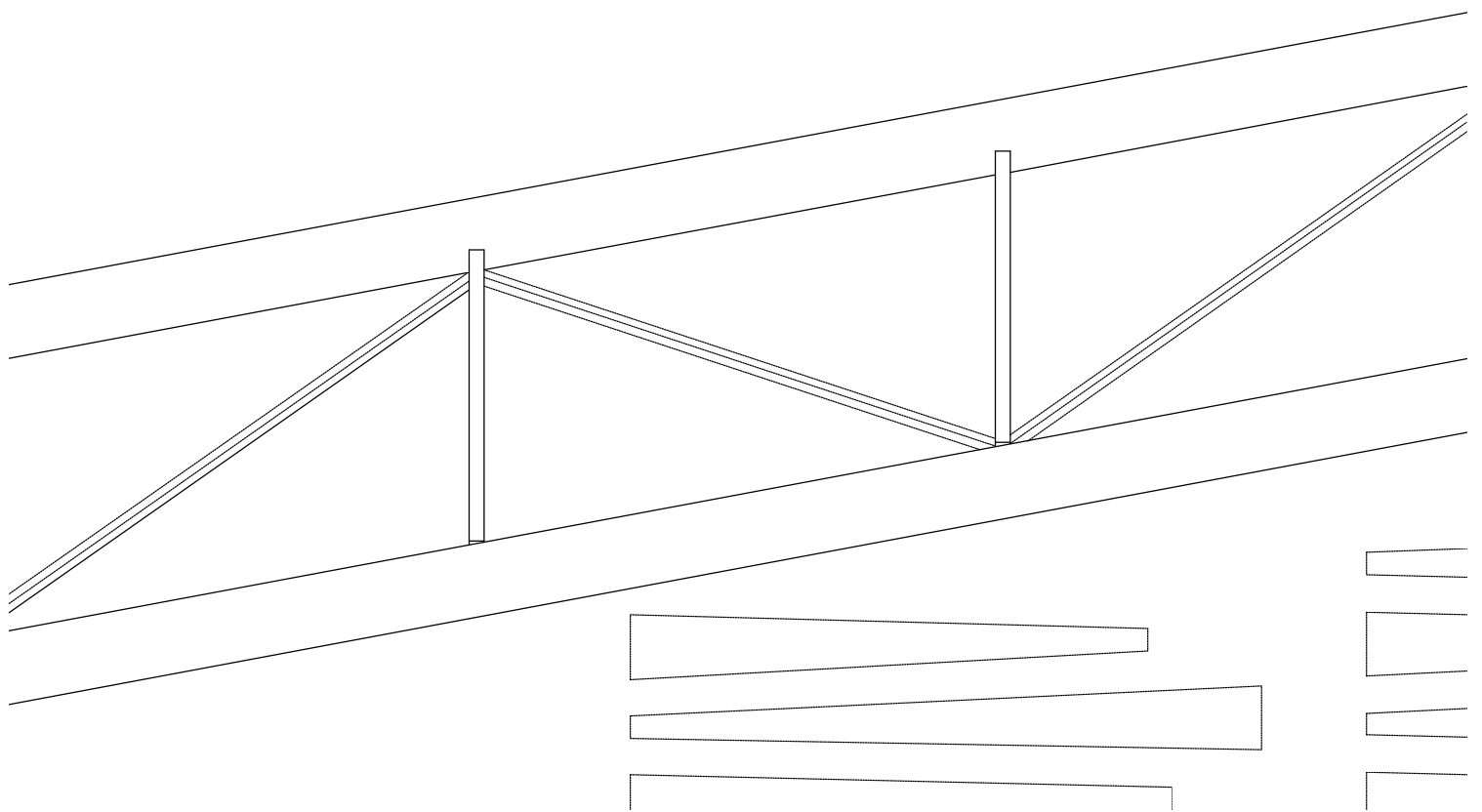
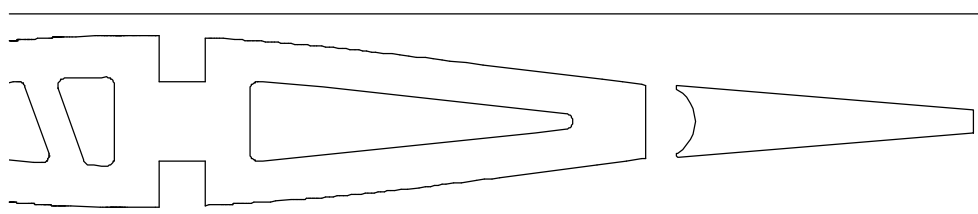
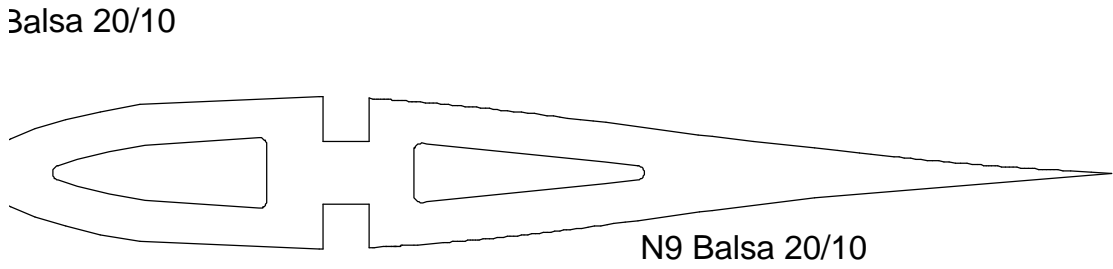
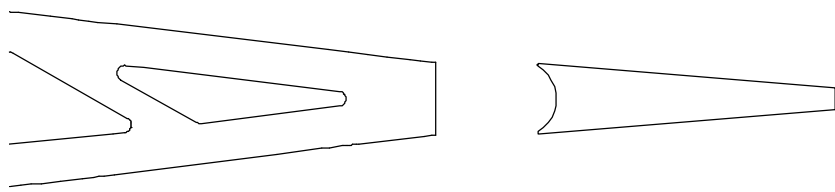
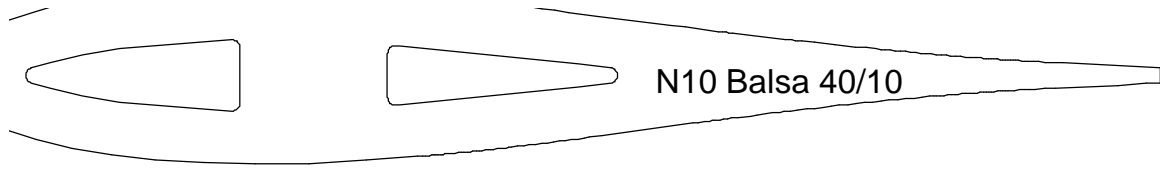

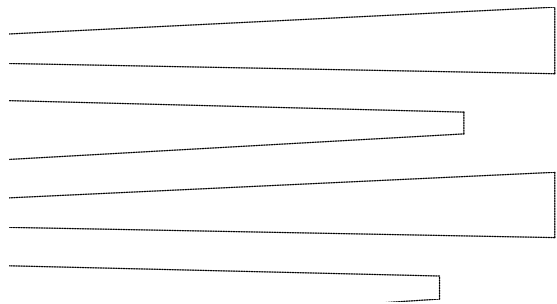
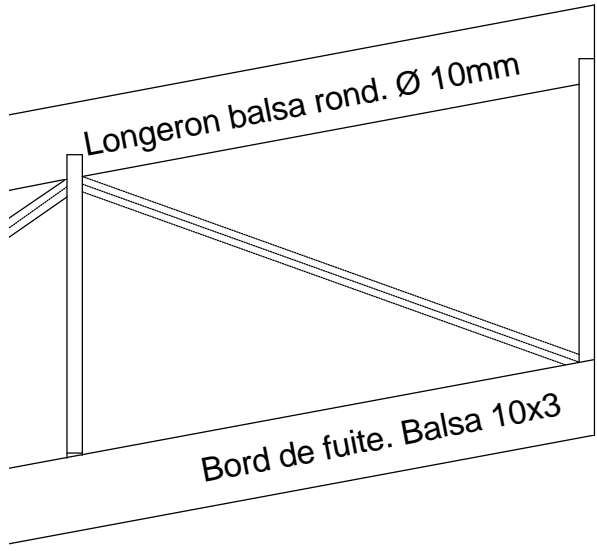

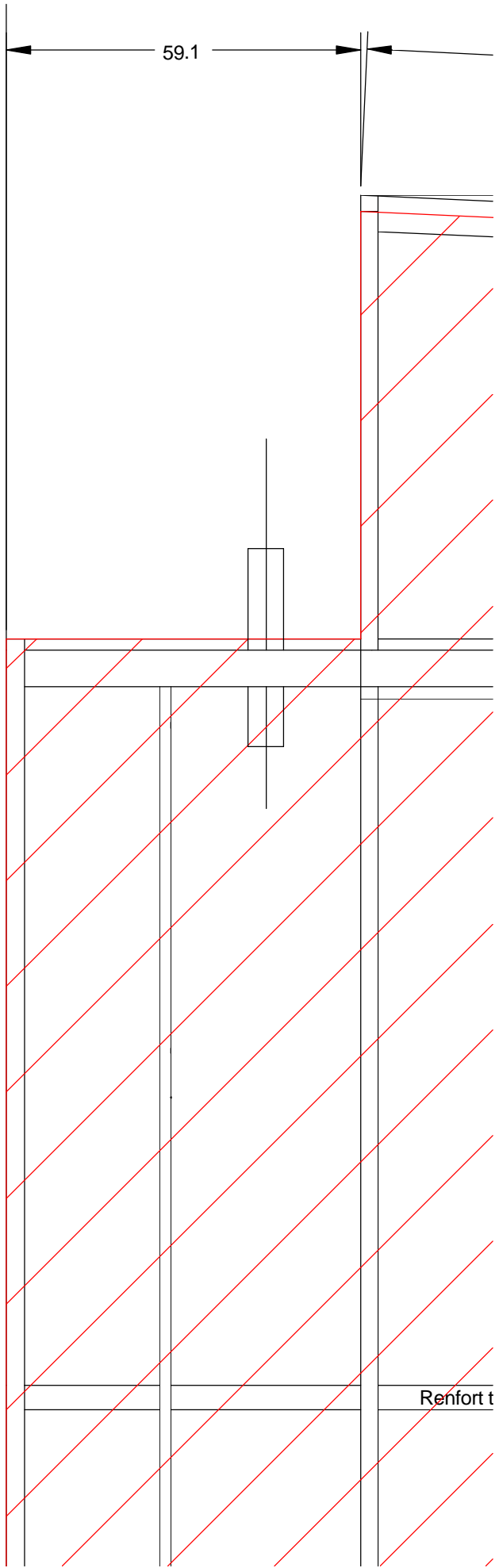

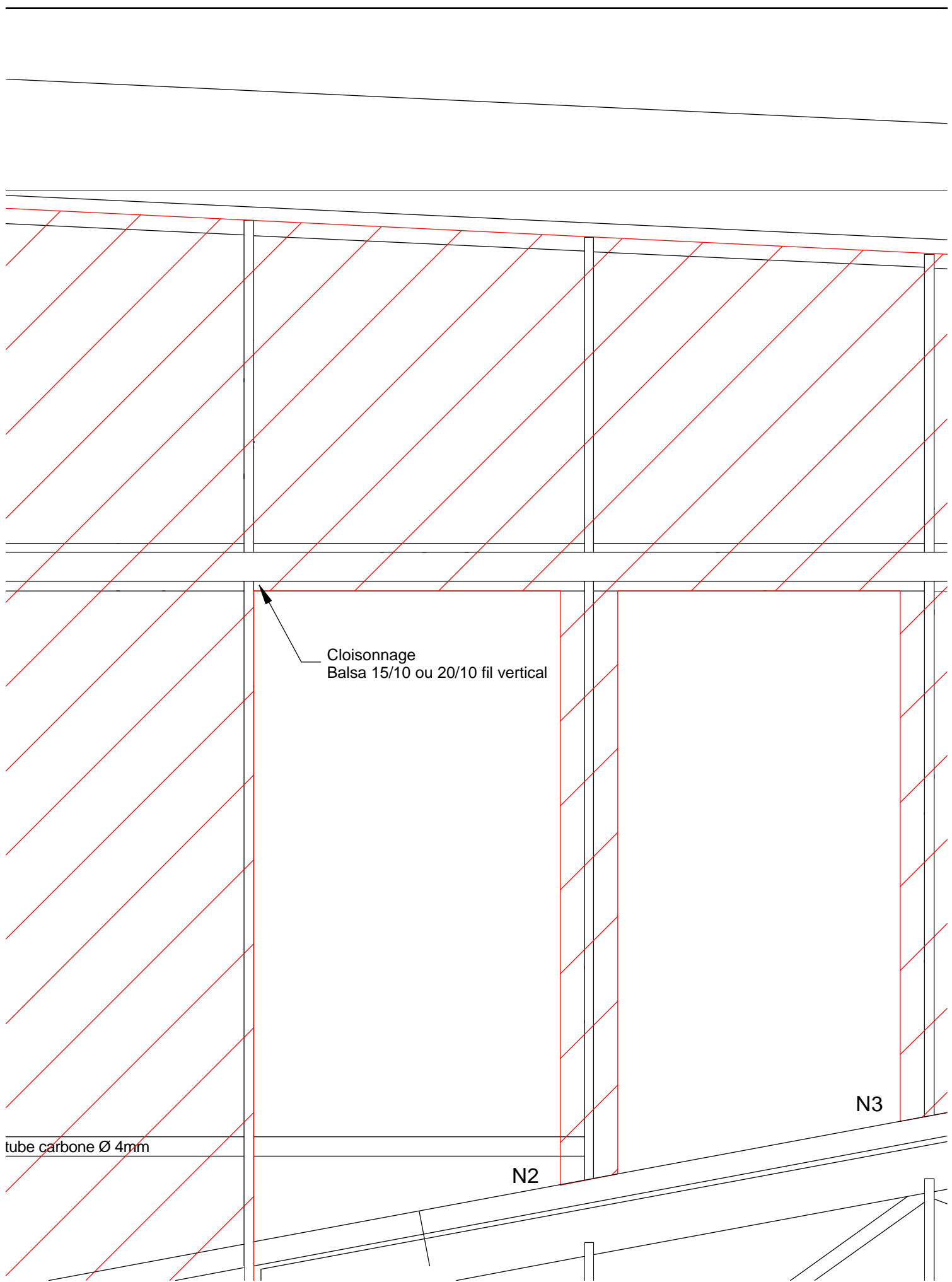

Cloisonnage
Balsa 15/10 ou 20/10 fil vertical

tube carbone Ø 4mm

N2

N3

578.3

N4

N5

↑

