

SPECIFICATIONS		
AIRCRAFT TYPE	1/2 A SPORT FLYER	
WING SPAN	35 3/4"	907 mm
WING CHORD	6 5/8"	168 mm
WING AREA	217 SQ. IN.	14 dm <sup>2</sup>
FUSELAGE LENGTH	24 3/8"	617 mm
ENGINE	.049 - .09	.8 - 1.5 CC
FUEL TANK	2 OZ.	60 CC
FUNCTIONS	ELEVATOR/AILERON	
CONTROL THROWS	1/4"	6 mm

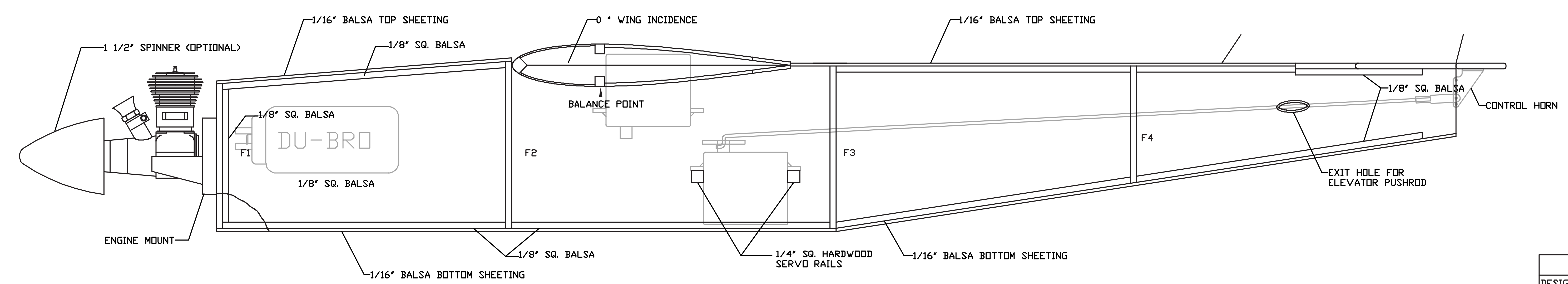

1/2A BUZZ BOMB  
 DESIGNED BY: MATTHEW FRANCIS  
 DATE: 05/04/2000  
 SCALE: 1:1  
 email: matthew\_francis@hotmail.com