

OneDesign

Designed and Drawn
By Michael Ramsey

Specifications:

- Wing Span - 32.0"
- Overall length - 27.7"
- Wing Area - 230 square inches
- Weight - 9-12 ounces

NOTES ABOUT MAKING TEMPLATES
Create templates using the outside edge of the line as a guide.
Use the center of the line as a guide for cutouts and hinge lines.

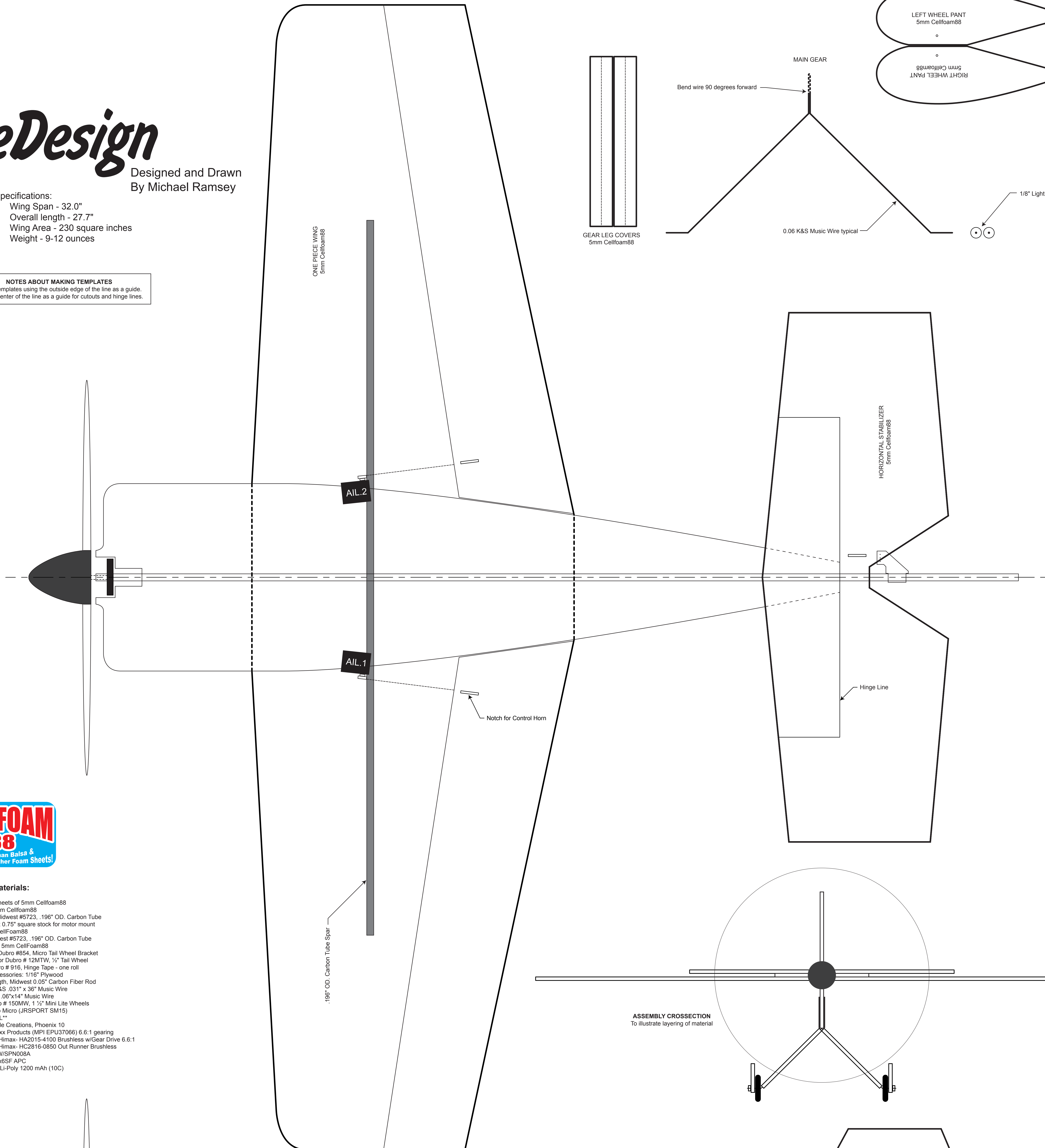
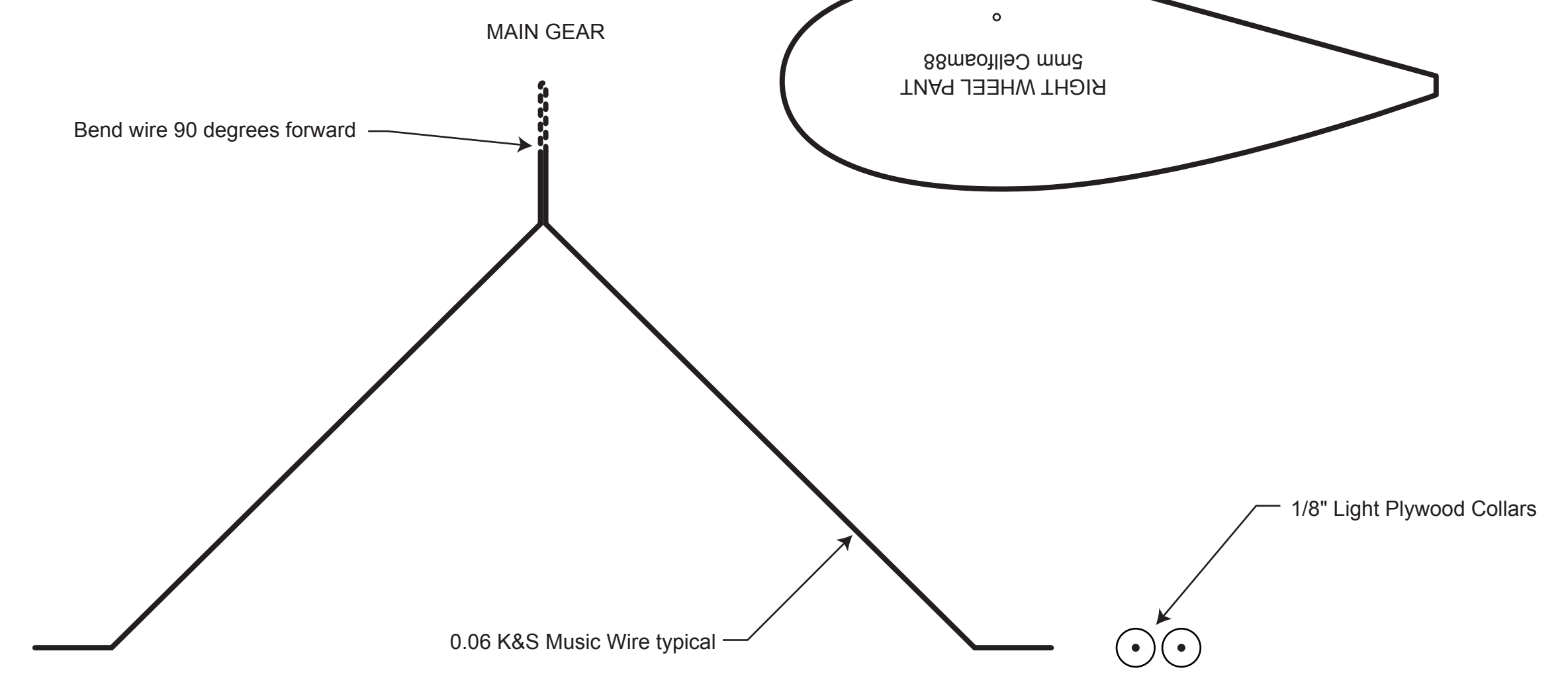
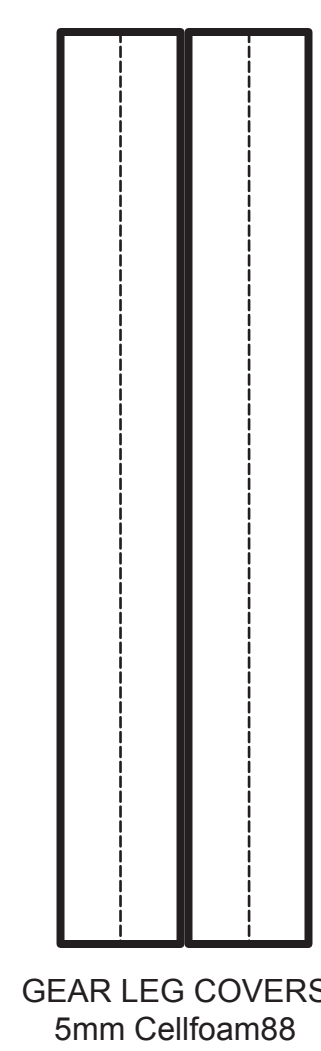
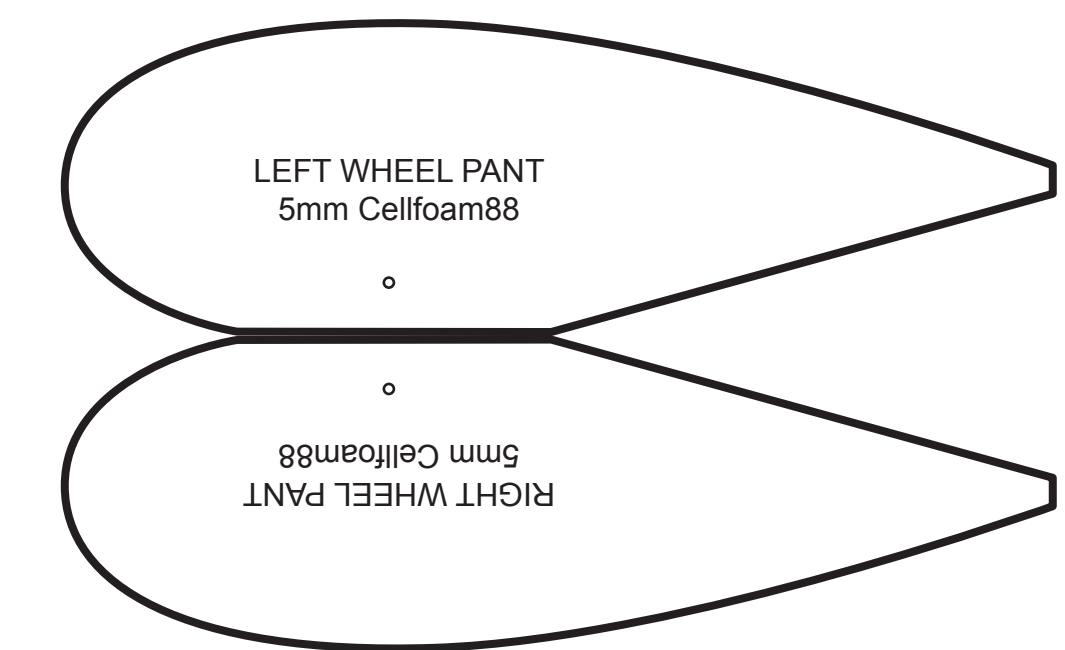

One Design Materials:

- Construction: Two sheets of 5mm Cellofoam88
- Fuselage: 5mm Cellofoam88
- Motor stick: Midwest #5723, .196" OD. Carbon Tube
- Control Horn: 3/8" x 0.75" square stock for motor mount
- Wing: 5mm Cellofoam88
- Spars: Midwest #5723, .196" OD. Carbon Tube
- Tail Surfaces: 5mm Cellofoam88
- Tail Skid (options): Dubro #854, Micro Tail Wheel Bracket
- Hinge Material: Dubro # 12MTW, 1/2" Tail Wheel
- Control Horns & Accessories: 1/16" Plywood
- Pushrods: 1-24" length, Midwest 0.05" Carbon Fiber Rod
- Pushrod Linkage: K&S .031" x .36" Music Wire
- Landing Gear: K&S .06"x14" Music Wire
- Main Wheels: Dubro # 150MW, 1 1/2" Mini Lite Wheels
- Servos: JR 241 Sub Micro (JRSPORT SM15)
- Receiver: JR 610 UL*
- Speed Control: Castle Creations, Phoenix 10
- Motor (options): Maxx Products (MPI EPU37066) 6.6:1 gearing
- or Himax: HA2015-4100 Brushless w/Gear Drive 6.6:1
- or Himax: HC2816-0850 Out Runner Brushless
- Spinner: GWS, # GW/SPN008A
- Prop: 11x7SF - 12x6SF APC
- Battery: 2 to 3 Cell Li-Poly 1200 mAh (10C)

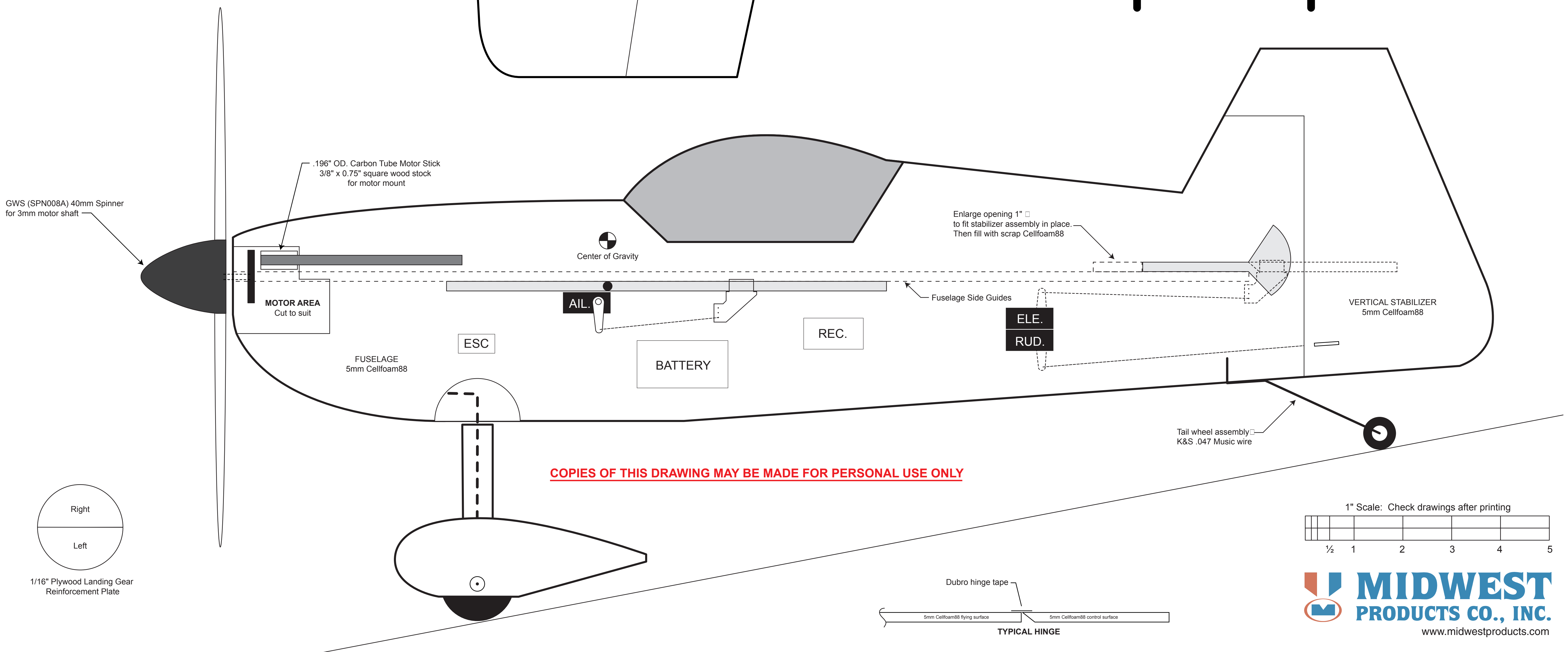
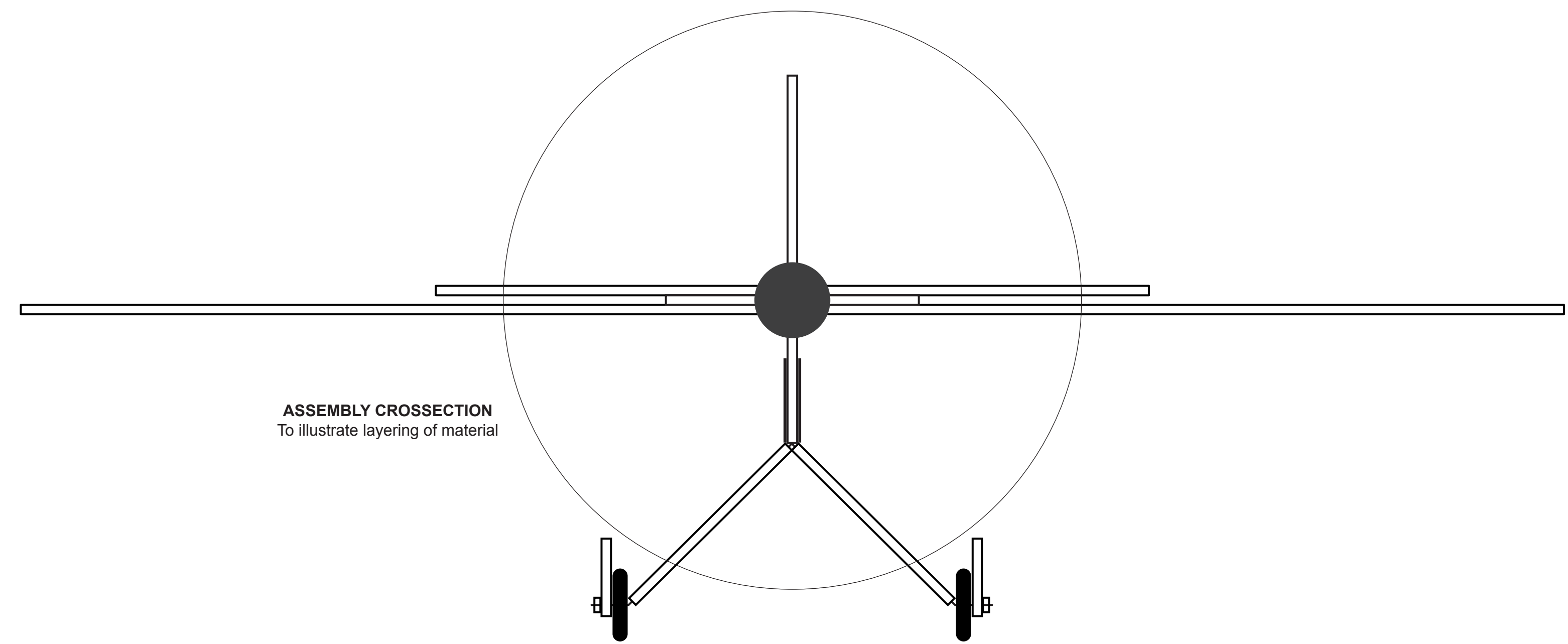

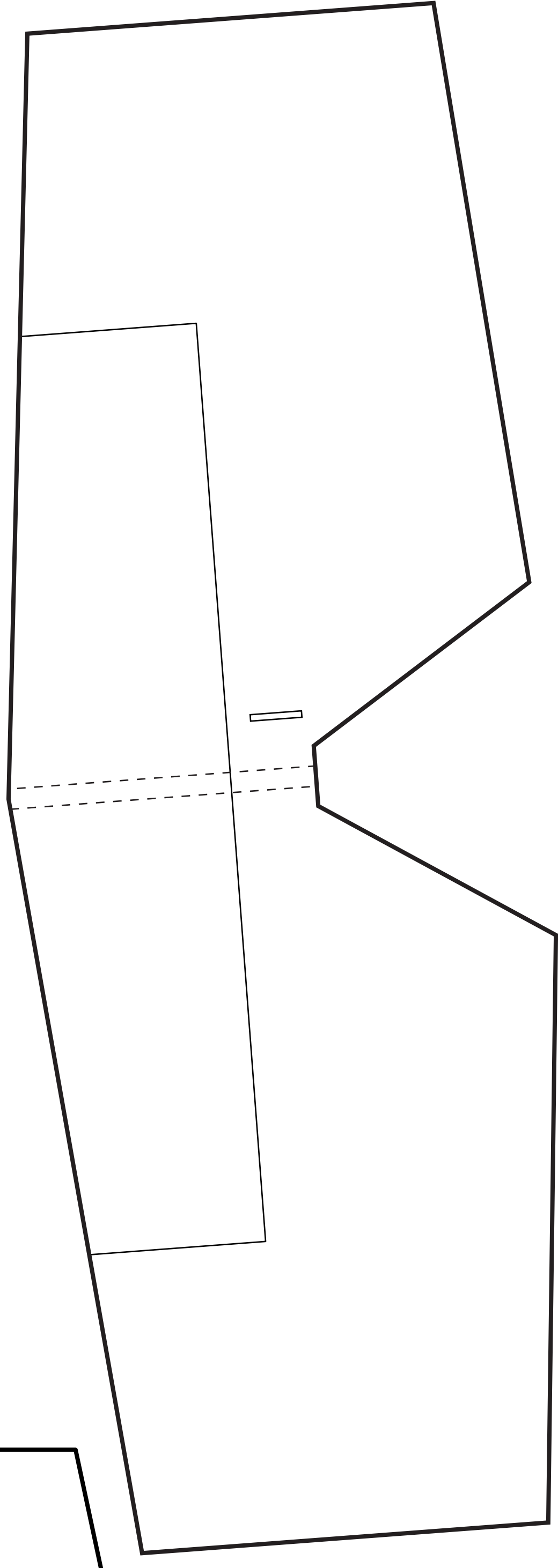
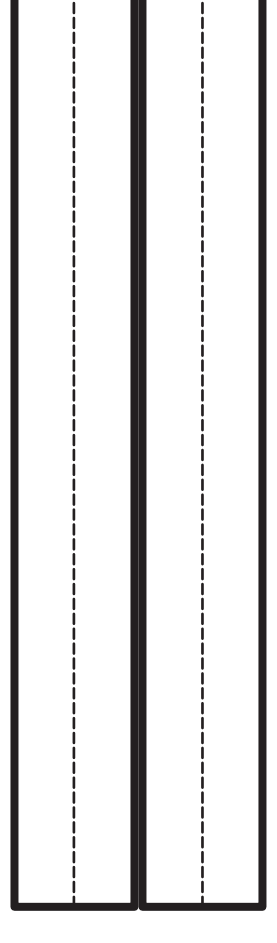

ONEDESIGN - 5 MM CELLFOAM 88 TEMPLATE

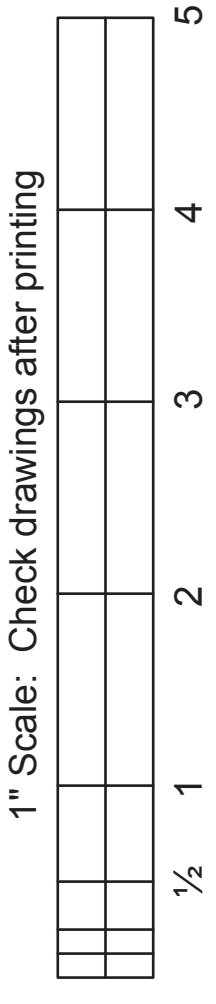
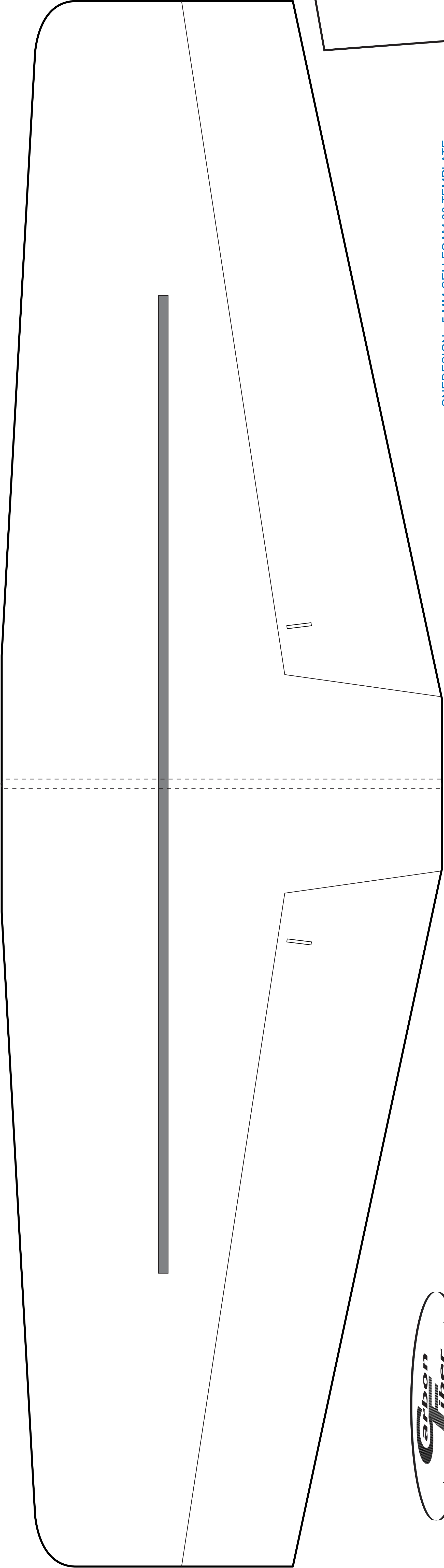

1" Scale: Check drawings after printing



COPIES OF THIS DRAWING
MAY BE MADE FOR PERSONAL USE ONLY

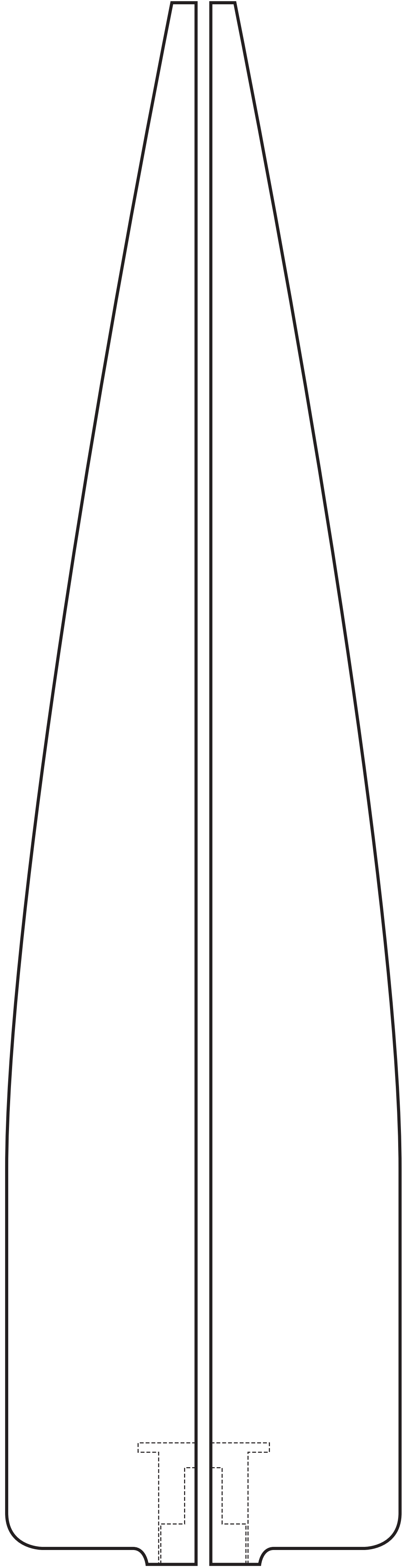

ONEDESIGN - 5 MM CELLFOAM 88 TEMPLATE

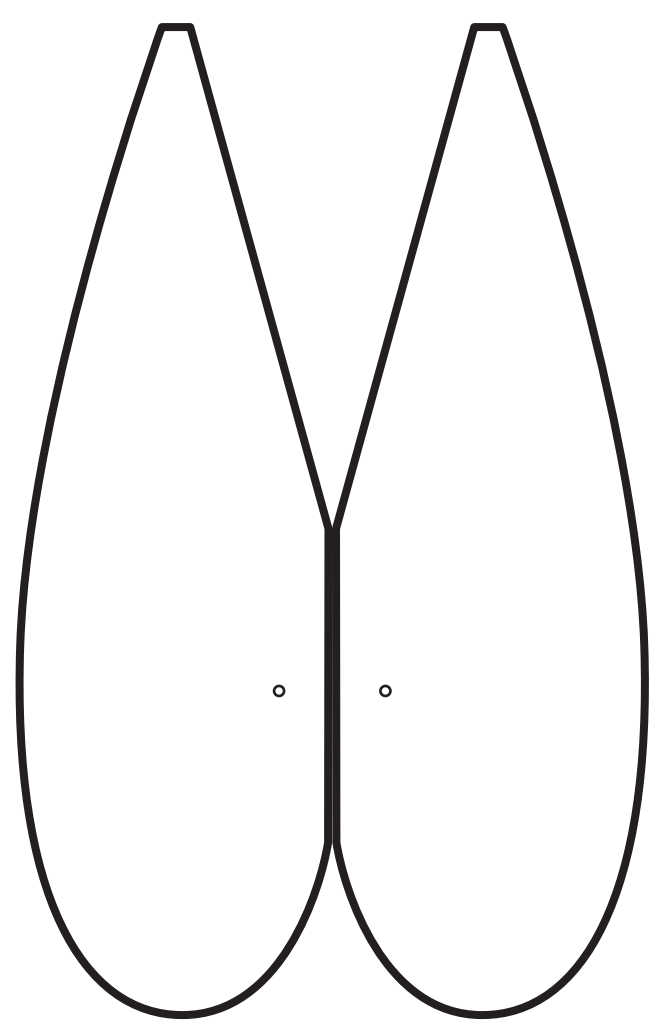
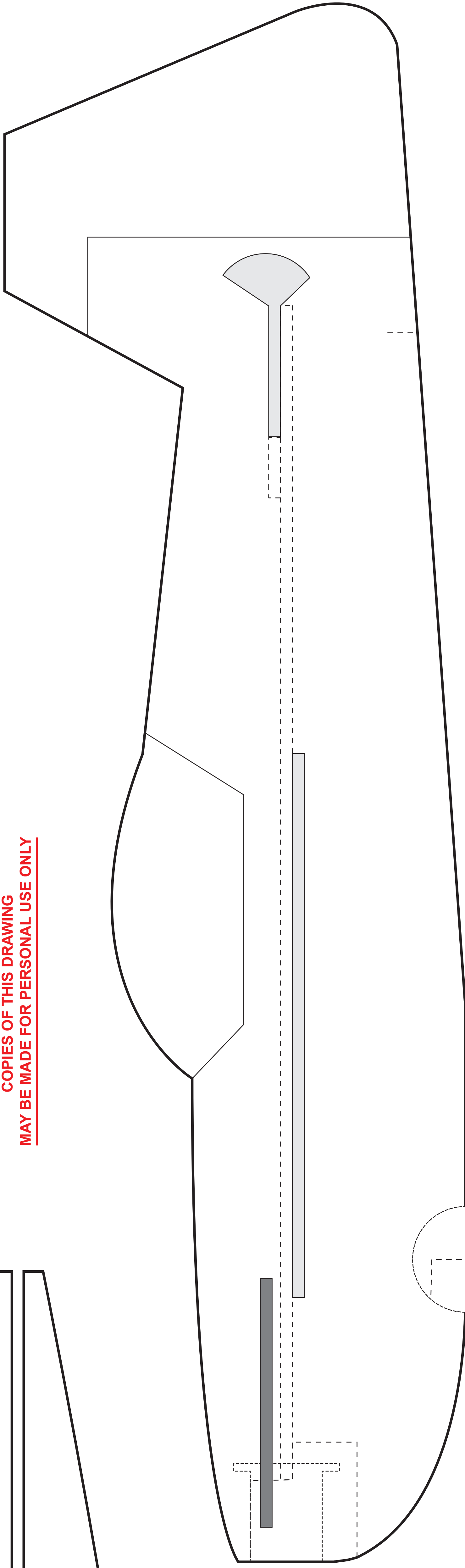

OneDesign

Designed and Drawn
By Michael Ramsey