

**Alternate Power:**  
**Razor RZ350 with the GWS EPS300C DS Gearbox**  
**3S 1200mh E-Tec LiPoly cells**  
**Power with this set-up is incredible!**

Note: For the elevator hinge, bevel the horizontal stabilizer, not the elevator. This allows easy hinging to clear the joiner wire.

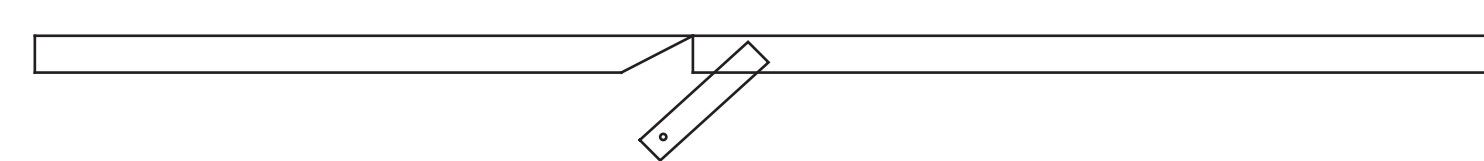

- Tape hinges are used to save weight. Use clear packing tape for hinges
1. Apply a piece of tape to the top of the control surface first.
  2. Make sure full deflection is used when lining up both surfaces.
  3. Smooth down tape.
  4. Now, fold control surface upward all the way as shown.
  5. Apply tape to bottom surface and smooth down.
  6. Check for freedom of movement.
  7. You are done. Easy huh?

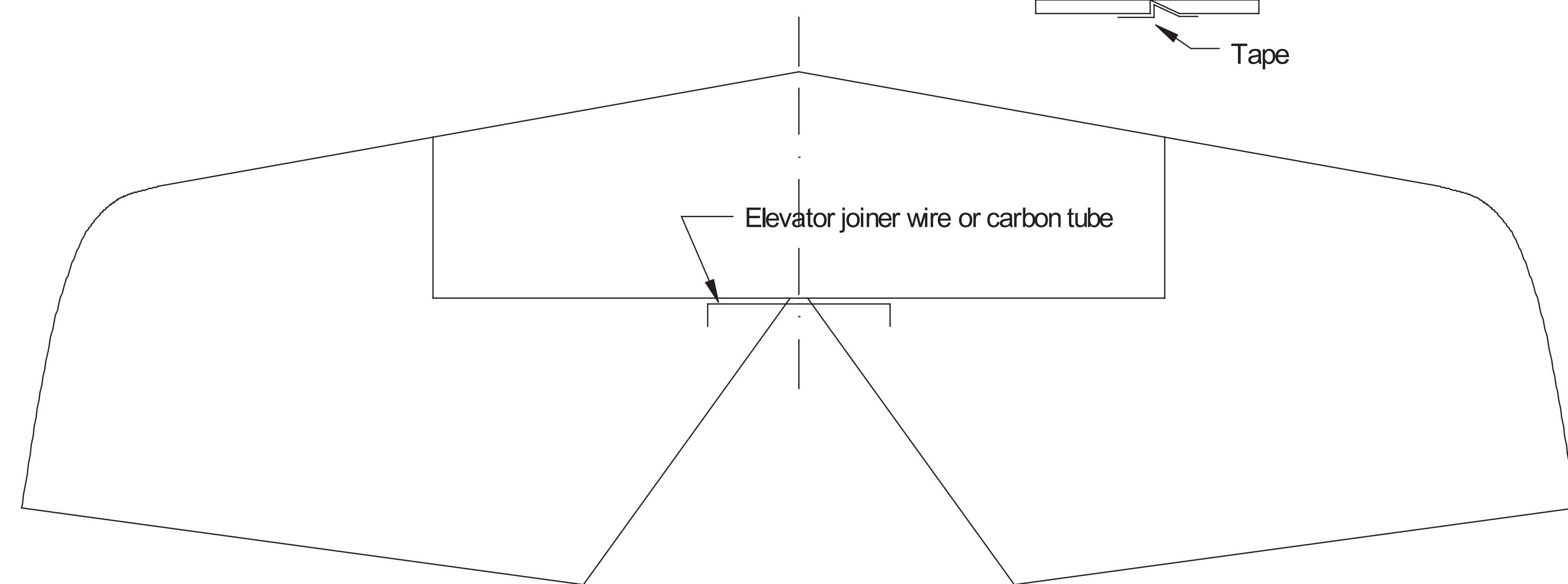
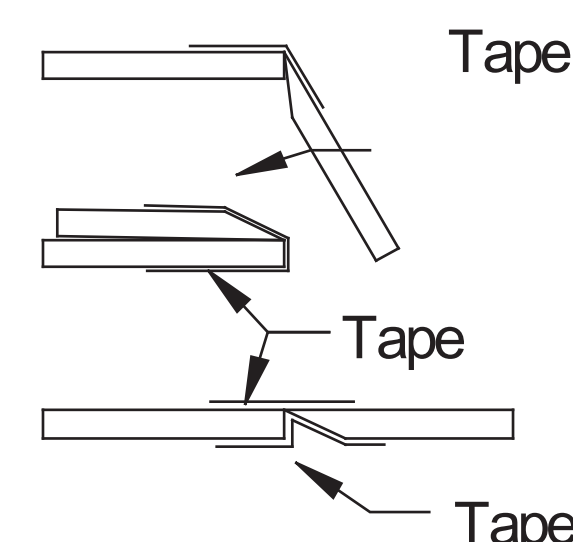

6mm Depron is available at [www.depronusa.com](http://www.depronusa.com)

Note: Construction material used is Dow Bluecore, AKA fan fold foam. 6mm Depron can be substituted.

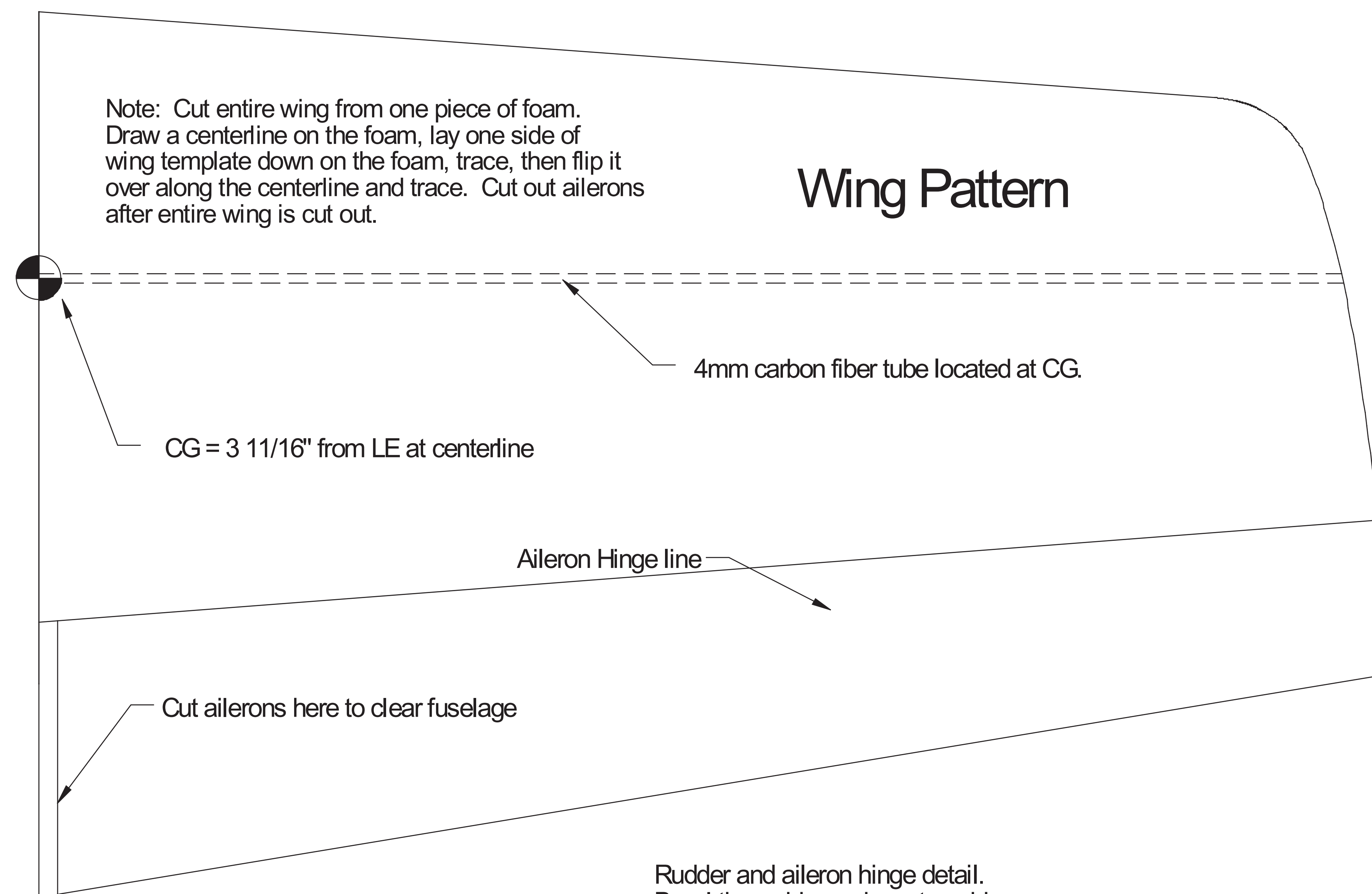

Rudder and aileron hinge detail. Bevel the rudder and use tape hinges.

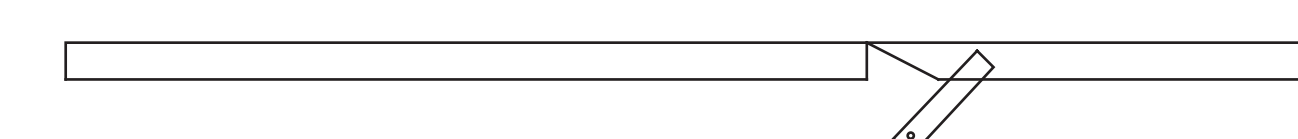

Control horn is made from a cut down zip tie.

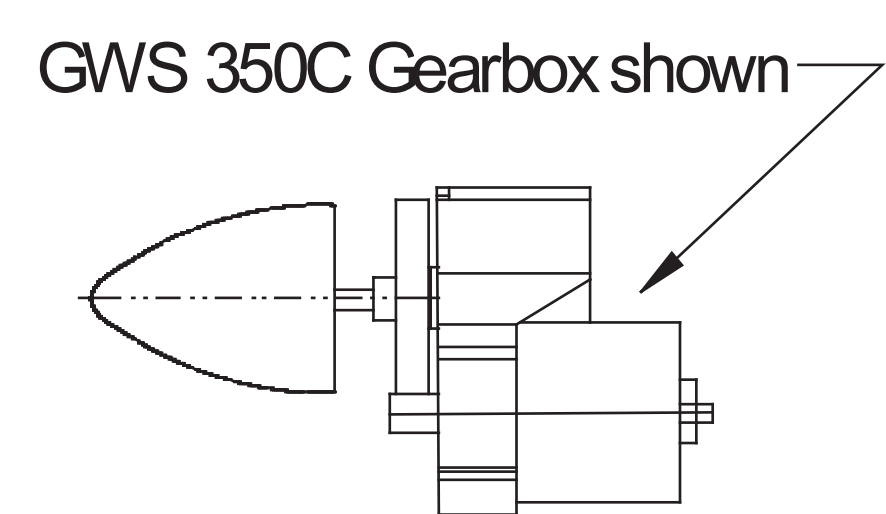

GWS 350C Gearbox shown

Note: Cut-out in fuselage is shown for GWS EPC 300-C gearbox and motor. If you are using another power system, adjust cut-out as required.

Initial CG here. Adjust to suite flying style and desired 3D performance. While building, try to locate all radio gear so that the plane will balance on the CG without the battery installed. If done so, battery can be used to adjust the CG. Also, batteries of different types can be substituted without drasidy changing CG.

\*\*Note: Servo placement shown on plans is for illustration purposes only. Adjust servo location to achieve CG without battery installed.\*\*

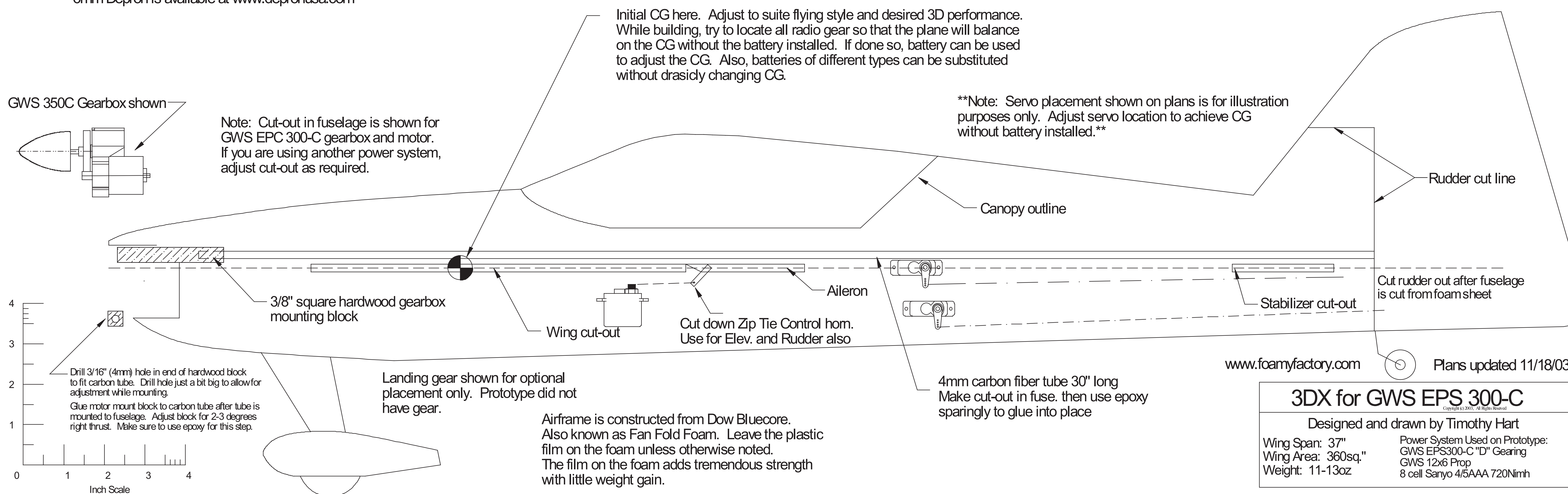

**3DX for GWS EPS 300-C**  
Copyright 2007. All Rights Reserved  
 Designed and drawn by Timothy Hart

Wing Span: 37"	Power System Used on Prototype:
Wing Area: 360sq."	GWS EPS300-C "D" Gearing
Weight: 11-13oz	GWS 12x6 Prop
	8 cell Sanyo 4/5AAA 720Nimh

# 3DX Plans Addendum

Wing cut-out is depicted incorrectly on the plans.  
The cut-out should be  $8 \frac{11}{32}$  in. long from the leading edge  
as shown on the plans.

